

Title 51 WAC

COMMUNITY, TRADE, AND ECONOMIC DEVELOPMENT, DEPARTMENT OF (BUILDING CODE COUNCIL)

Chapters

- 51-04 Policies and procedures for consideration of statewide and local amendments to the State Building Code.
- 51-06 Public records.
- 51-08 Uniform procedural rules.
- 51-11 Washington State Energy Code.
- 51-13 Ventilation and indoor air quality.
- 51-16 State Building Code Guidelines.
- 51-19 Washington State Historic Building Code.
- 51-40 State Building Code adoption and amendment of the 1997 edition of the Uniform Building Code.
- 51-42 State Building Code adoption and amendment of the 1997 edition of the Uniform Mechanical Code.
- 51-44 State Building Code adoption and amendment of the 1997 edition of the Uniform Fire Code.
- 51-45 State Building Code adoption and amendment of the 1997 edition of the Uniform Fire Code Standards.
- 51-56 State Building Code adoption and amendment of the 2000 edition of the Uniform Plumbing Code.
- 51-57 State Building Code adoption and amendment of Appendix A and Appendix I of the 2000 edition of the Uniform Plumbing Code.

- 7/1/89. Statutory Authority: RCW 19.27A.020 and chapter 19.27A RCW. 86-20-024 (Resolution No. 86-17), § 51-12-102, filed 9/23/86; 86-11-013 (Order 86-04), § 51-12-102, filed 5/13/86. Statutory Authority: 1985 c 144. 85-24-028 (Order 85-14), § 51-12-102, filed 11/26/85.] Repealed by 91-01-112, filed 12/19/90, effective 7/1/91. Statutory Authority: RCW 19.27A.020 and 1990 c 2.
- 51-12-103 Section 103. Conflicts with other codes. [Statutory Authority: 1985 c 144. 85-24-028 (Order 85-14), § 51-12-103, filed 11/26/85.] Repealed by 91-01-112, filed 12/19/90, effective 7/1/91. Statutory Authority: RCW 19.27A.020 and 1990 c 2.
- 51-12-104 Section 104. Materials and equipment. [Statutory Authority: 1985 c 144. 85-24-028 (Order 85-14), § 51-12-104, filed 11/26/85.] Repealed by 91-01-112, filed 12/19/90, effective 7/1/91. Statutory Authority: RCW 19.27A.020 and 1990 c 2.
- 51-12-105 Section 105. Alternate materials—Method of construction, design or insulating systems. [Statutory Authority: 1985 c 144. 85-24-028 (Order 85-14), § 51-12-105, filed 11/26/85.] Repealed by 91-01-112, filed 12/19/90, effective 7/1/91. Statutory Authority: RCW 19.27A.020 and 1990 c 2.
- 51-12-106 Section 106. Plans and specifications. [Statutory Authority: 1985 c 144. 85-24-028 (Order 85-14), § 51-12-106, filed 11/26/85.] Repealed by 91-01-112, filed 12/19/90, effective 7/1/91. Statutory Authority: RCW 19.27A.020 and 1990 c 2.
- 51-12-107 Section 107. Inspections and enforcement. [Statutory Authority: 1985 c 144. 85-24-028 (Order 85-14), § 51-12-107, filed 11/26/85.] Repealed by 91-01-112, filed 12/19/90, effective 7/1/91. Statutory Authority: RCW 19.27A.020 and 1990 c 2.
- 51-12-108 Section 108. Severability. [Statutory Authority: 1985 c 144. 85-24-028 (Order 85-14), § 51-12-108, filed 11/26/85.] Repealed by 91-01-112, filed 12/19/90, effective 7/1/91. Statutory Authority: RCW 19.27A.020 and 1990 c 2.
- 51-12-109 Section 109. Violations. [Statutory Authority: 1985 c 144. 85-24-028 (Order 85-14), § 51-12-109, filed 11/26/85.] Repealed by 91-01-112, filed 12/19/90, effective 7/1/91. Statutory Authority: RCW 19.27A.020 and 1990 c 2.
- 51-12-110 Section 110. Liability. [Statutory Authority: 1985 c 144. 85-24-028 (Order 85-14), § 51-12-110, filed 11/26/85.] Repealed by 91-01-112, filed 12/19/90, effective 7/1/91. Statutory Authority: RCW 19.27A.020 and 1990 c 2.
- 51-12-200 Section 200. General. [Statutory Authority: 1985 c 144. 85-24-028 (Order 85-14), § 51-12-200, filed 11/26/85.] Repealed by 91-01-112, filed 12/19/90, effective 7/1/91. Statutory Authority: RCW 19.27A.020 and 1990 c 2.
- 51-12-201 Section 201. A. [Statutory Authority: RCW 19.27A.020 and chapter 19.27A RCW. 86-20-024 (Resolution No. 86-17), § 51-12-201, filed 9/23/86. Statutory Authority: 1985 c 144. 85-24-028 (Order 85-14), § 51-12-201, filed 11/26/85.] Repealed by 91-01-112, filed 12/19/90, effective 7/1/91. Statutory Authority: RCW 19.27A.020 and 1990 c 2.
- 51-12-202 Section 202. B. [Statutory Authority: 1985 c 144. 85-24-028 (Order 85-14), § 51-12-202, filed 11/26/85.] Repealed by 91-01-112, filed 12/19/90, effective 7/1/91. Statutory Authority: RCW 19.27A.020 and 1990 c 2.
- 51-12-203 Section 203. C. [Statutory Authority: 1985 c 144. 85-24-028 (Order 85-14), § 51-12-203, filed 11/26/85.] Repealed by 91-01-112, filed 12/19/90, effective 7/1/91. Statutory Authority: RCW 19.27A.020 and 1990 c 2.

DISPOSITION OF CHAPTERS FORMERLY CODIFIED IN THIS TITLE

Chapter 51-10 BARRIER-FREE FACILITIES

- 51-10 Barrier-free facilities [Statutory Authority: Chapters 19.27, 19.27A and 70.92 RCW and 1989 c 266. 90-02-110, filed 1/3/90, effective 7/1/90. Statutory Authority: Chapters 19.27 and 70.92 RCW. 88-24-021 (Order 88-09), filed 12/2/88, effective 7/1/89; 86-24-040 (Order 86-18), filed 11/26/86, effective 4/27/87; 85-07-036 (Order 85-02), filed 3/18/85; 85-03-095 (Order 85-01), filed 1/22/85; 83-15-033 (Order 83-4), filed 7/18/83; Order 77-02, filed 8/3/77; Order 76-02, filed 9/1/76; Order 76-01, filed 6/28/76.] Repealed by 92-01-130, filed 12/19/91, effective 7/1/92. Statutory Authority: Chapters 70.92 and 19.27 RCW.

Chapter 51-12 WASHINGTON STATE ENERGY CODE

- 51-12-100 Section 100. Title. [Statutory Authority: 1985 c 144. 85-24-028 (Order 85-14), § 51-12-100, filed 11/26/85.] Repealed by 91-01-112, filed 12/19/90, effective 7/1/91. Statutory Authority: RCW 19.27A.020 and 1990 c 2.
- 51-12-101 Section 101. Intent. [Statutory Authority: 1985 c 144. 85-24-028 (Order 85-14), § 51-12-101, filed 11/26/85.] Repealed by 91-01-112, filed 12/19/90, effective 7/1/91. Statutory Authority: RCW 19.27A.020 and 1990 c 2.
- 51-12-102 Section 102. Scope. [Statutory Authority: RCW 19.27.074, 19.27A.010 and 19.27A.020. 89-04-043 (Order 88-10), § 51-12-102, filed 1/31/89, effective

51-12-204	Section 204. D. [Statutory Authority: 1985 c 144. 85-24-028 (Order 85-14), § 51-12-204, filed 11/26/85.] Repealed by 91-01-112, filed 12/19/90, effective 7/1/91. Statutory Authority: RCW 19.27A.020 and 1990 c 2.	51-12-222	Section 222. V. [Statutory Authority: 1985 c 144. 85-24-028 (Order 85-14), § 51-12-222, filed 11/26/85.] Repealed by 91-01-112, filed 12/19/90, effective 7/1/91. Statutory Authority: RCW 19.27A.020 and 1990 c 2.
51-12-205	Section 205. E. [Statutory Authority: 1985 c 144. 85-24-028 (Order 85-14), § 51-12-205, filed 11/26/85.] Repealed by 91-01-112, filed 12/19/90, effective 7/1/91. Statutory Authority: RCW 19.27A.020 and 1990 c 2.	51-12-223	Section 223. W X Y Z. [Statutory Authority: RCW 19.27.074, 19.27A.010 and 19.27A.020. 89-04-043 (Order 88-10), § 51-12-223, filed 1/31/89, effective 7/1/89. Statutory Authority: 1985 c 144. 85-24-028 (Order 85-14), § 51-12-223, filed 11/26/85.] Repealed by 91-01-112, filed 12/19/90, effective 7/1/91. Statutory Authority: RCW 19.27A.020 and 1990 c 2.
51-12-206	Section 206. F. [Statutory Authority: RCW 19.27.074, 19.27A.010 and 19.27A.020. 89-04-043 (Order 88-10), § 51-12-206, filed 1/31/89, effective 7/1/89. Statutory Authority: 1985 c 144. 85-24-028 (Order 85-14), § 51-12-206, filed 11/26/85.] Repealed by 91-01-112, filed 12/19/90, effective 7/1/91. Statutory Authority: RCW 19.27A.020 and 1990 c 2.	51-12-300	Section 300. General. [Statutory Authority: 1985 c 144. 85-24-028 (Order 85-14), § 51-12-300, filed 11/26/85.] Repealed by 91-01-112, filed 12/19/90, effective 7/1/91. Statutory Authority: RCW 19.27A.020 and 1990 c 2.
51-12-207	Section 207. G. [Statutory Authority: 1985 c 144. 85-24-028 (Order 85-14), § 51-12-207, filed 11/26/85.] Repealed by 91-01-112, filed 12/19/90, effective 7/1/91. Statutory Authority: RCW 19.27A.020 and 1990 c 2.	51-12-301	Section 301. Heated and cooled buildings. [Statutory Authority: 1985 c 144. 85-24-028 (Order 85-14), § 51-12-301, filed 11/26/85.] Repealed by 91-01-112, filed 12/19/90, effective 7/1/91. Statutory Authority: RCW 19.27A.020 and 1990 c 2.
51-12-208	Section 208. H. [Statutory Authority: 1985 c 144. 85-24-028 (Order 85-14), § 51-12-208, filed 11/26/85.] Repealed by 91-01-112, filed 12/19/90, effective 7/1/91. Statutory Authority: RCW 19.27A.020 and 1990 c 2.	51-12-302	Section 302. Climatic Zones. [Statutory Authority: 1985 c 144. 85-24-028 (Order 85-14), § 51-12-302, filed 11/26/85.] Repealed by 91-01-112, filed 12/19/90, effective 7/1/91. Statutory Authority: RCW 19.27A.020 and 1990 c 2.
51-12-209	Section 209. I. [Statutory Authority: 1985 c 144. 85-24-028 (Order 85-14), § 51-12-209, filed 11/26/85.] Repealed by 91-01-112, filed 12/19/90, effective 7/1/91. Statutory Authority: RCW 19.27A.020 and 1990 c 2.	51-12-303	Section 303. Departures. [Statutory Authority: 1985 c 144. 85-24-028 (Order 85-14), § 51-12-303, filed 11/26/85.] Repealed by 91-01-112, filed 12/19/90, effective 7/1/91. Statutory Authority: RCW 19.27A.020 and 1990 c 2.
51-12-210	Section 210. J. (Reserved). [Statutory Authority: 1985 c 144. 85-24-028 (Order 85-14), § 51-12-210, filed 11/26/85.] Repealed by 91-01-112, filed 12/19/90, effective 7/1/91. Statutory Authority: RCW 19.27A.020 and 1990 c 2.	51-12-304	Section 304. Design parameters. [Statutory Authority: RCW 19.27A.020 and chapter 19.27A RCW. 86-20-024 (Resolution No. 86-17), § 51-12-304, filed 9/23/86. Statutory Authority: 1985 c 144. 85-24-028 (Order 85-14), § 51-12-304, filed 11/26/85.] Repealed by 91-01-112, filed 12/19/90, effective 7/1/91. Statutory Authority: RCW 19.27A.020 and 1990 c 2.
51-12-211	Section 211. K. (Reserved). [Statutory Authority: 1985 c 144. 85-24-028 (Order 85-14), § 51-12-211, filed 11/26/85.] Repealed by 91-01-112, filed 12/19/90, effective 7/1/91. Statutory Authority: RCW 19.27A.020 and 1990 c 2.	51-12-305	Section 305. Ventilation. [Statutory Authority: RCW 19.27.074, 19.27A.010 and 19.27A.020. 89-04-043 (Order 88-10), § 51-12-305, filed 1/31/89, effective 7/1/89. Statutory Authority: 1985 c 144. 85-24-028 (Order 85-14), § 51-12-305, filed 11/26/85.] Repealed by 91-01-112, filed 12/19/90, effective 7/1/91. Statutory Authority: RCW 19.27A.020 and 1990 c 2.
51-12-212	Section 212. L. [Statutory Authority: 1985 c 144. 85-24-028 (Order 85-14), § 51-12-212, filed 11/26/85.] Repealed by 91-01-112, filed 12/19/90, effective 7/1/91. Statutory Authority: RCW 19.27A.020 and 1990 c 2.	51-12-400	Section 400. General. [Statutory Authority: 1985 c 144. 85-24-028 (Order 85-14), § 51-12-400, filed 11/26/85.] Repealed by 91-01-112, filed 12/19/90, effective 7/1/91. Statutory Authority: RCW 19.27A.020 and 1990 c 2.
51-12-213	Section 213. M. [Statutory Authority: 1985 c 144. 85-24-028 (Order 85-14), § 51-12-213, filed 11/26/85.] Repealed by 91-01-112, filed 12/19/90, effective 7/1/91. Statutory Authority: RCW 19.27A.020 and 1990 c 2.	51-12-401	Section 401. (Reserved). [Statutory Authority: 1985 c 144. 85-24-028 (Order 85-14), § 51-12-401, filed 11/26/85.] Repealed by 91-01-112, filed 12/19/90, effective 7/1/91. Statutory Authority: RCW 19.27A.020 and 1990 c 2.
51-12-214	Section 214. N. [Statutory Authority: 1985 c 144. 85-24-028 (Order 85-14), § 51-12-214, filed 11/26/85.] Repealed by 91-01-112, filed 12/19/90, effective 7/1/91. Statutory Authority: RCW 19.27A.020 and 1990 c 2.	51-12-402	Section 402. Overall thermal performance and building envelope requirements. [Statutory Authority: RCW 19.27.074, 19.27A.010 and 19.27A.020. 89-04-043 (Order 88-10), § 51-12-402, filed 1/31/89, effective 7/1/89. Statutory Authority: RCW 19.27A.020 and chapter 19.27A RCW. 86-20-024 (Resolution No. 86-17), § 51-12-402, filed 9/23/86. Statutory Authority: 1985 c 144. 85-24-028 (Order 85-14), § 51-12-402, filed 11/26/85.] Repealed by 91-01-112, filed 12/19/90, effective 7/1/91. Statutory Authority: RCW 19.27A.020 and 1990 c 2.
51-12-215	Section 215. O. [Statutory Authority: 1985 c 144. 85-24-028 (Order 85-14), § 51-12-215, filed 11/26/85.] Repealed by 91-01-112, filed 12/19/90, effective 7/1/91. Statutory Authority: RCW 19.27A.020 and 1990 c 2.	51-12-403	Section 403. Thermal performance criteria and envelope requirements for low-rise residential buildings. [Statutory Authority: Chapters 19.27, 19.27A and 70.92 RCW, and 1989 c 266. 90-02-110, § 51-12-403, filed 1/3/90, effective 7/1/90. Statutory Authority: 1985 c 144. 85-24-028 (Order 85-14), § 51-12-403, filed 11/26/85.] Repealed by 91-01-112, filed 12/19/90, effective 7/1/91. Statutory Authority: RCW 19.27A.020 and 1990 c 2.
51-12-216	Section 216. P. [Statutory Authority: 1985 c 144. 85-24-028 (Order 85-14), § 51-12-216, filed 11/26/85.] Repealed by 91-01-112, filed 12/19/90, effective 7/1/91. Statutory Authority: RCW 19.27A.020 and 1990 c 2.	51-12-404	Section 404. Thermal performance criteria for all other occupancies. [Statutory Authority: Chapters 19.27, 19.27A and 70.92 RCW, and 1989 c 266. 90-02-110, § 51-12-404, filed 1/3/90, effective 7/1/90. Statutory Authority: RCW 19.27A.020 and chapter 19.27A RCW. 86-11-013 (Order 86-04), § 51-12-404, filed 5/13/86. Statutory Authority: 1985 c 144. 85-24-028 (Order 85-14), § 51-12-404, filed 11/26/85.] Repealed by 91-01-112, filed 12/19/90, effective 7/1/91. Statutory Authority: RCW 19.27A.020 and 1990 c 2.
51-12-217	Section 217. Q. (Reserved). [Statutory Authority: 1985 c 144. 85-24-028 (Order 85-14), § 51-12-217, filed 11/26/85.] Repealed by 91-01-112, filed 12/19/90, effective 7/1/91. Statutory Authority: RCW 19.27A.020 and 1990 c 2.		
51-12-218	Section 218. R. [Statutory Authority: 1985 c 144. 85-24-028 (Order 85-14), § 51-12-218, filed 11/26/85.] Repealed by 91-01-112, filed 12/19/90, effective 7/1/91. Statutory Authority: RCW 19.27A.020 and 1990 c 2.		
51-12-219	Section 219. S. [Statutory Authority: RCW 19.27.074, 19.27A.010 and 19.27A.020. 89-04-043 (Order 88-10), § 51-12-219, filed 1/31/89, effective 7/1/89. Statutory Authority: 1985 c 144. 85-24-028 (Order 85-14), § 51-12-219, filed 11/26/85.] Repealed by 91-01-112, filed 12/19/90, effective 7/1/91. Statutory Authority: RCW 19.27A.020 and 1990 c 2.		
51-12-220	Section 220. T. [Statutory Authority: Chapters 19.27, 19.27A and 70.92 RCW, and 1989 c 266. 90-02-110, § 51-12-220, filed 1/3/90, effective 7/1/90. Statutory Authority: 1985 c 144. 85-24-028 (Order 85-14), § 51-12-220, filed 11/26/85.] Repealed by 91-01-112, filed 12/19/90, effective 7/1/91. Statutory Authority: RCW 19.27A.020 and 1990 c 2.		
51-12-221	Section 221. U. [Statutory Authority: 1985 c 144. 85-24-028 (Order 85-14), § 51-12-221, filed 11/26/85.] Repealed by 91-01-112, filed 12/19/90, effective 7/1/91. Statutory Authority: RCW 19.27A.020 and 1990 c 2.		

- 51-12-405 Section 405. Air leakage for all buildings. [Statutory Authority: 1985 c 144. 85-24-028 (Order 85-14), § 51-12-405, filed 11/26/85.] Repealed by 91-01-112, filed 12/19/90, effective 7/1/91. Statutory Authority: RCW 19.27A.020 and 1990 c 2.
- 51-12-406 Section 406. Building mechanical systems. [Statutory Authority: 1985 c 144. 85-24-028 (Order 85-14), § 51-12-406, filed 11/26/85.] Repealed by 91-01-112, filed 12/19/90, effective 7/1/91. Statutory Authority: RCW 19.27A.020 and 1990 c 2.
- 51-12-407 Section 407. Calculations of heating and cooling loads and system sizing limits. [Statutory Authority: 1985 c 144. 85-24-028 (Order 85-14), § 51-12-407, filed 11/26/85.] Repealed by 91-01-112, filed 12/19/90, effective 7/1/91. Statutory Authority: RCW 19.27A.020 and 1990 c 2.
- 51-12-408 Section 408. (Reserved). [Statutory Authority: 1985 c 144. 85-24-028 (Order 85-14), § 51-12-408, filed 11/26/85.] Repealed by 91-01-112, filed 12/19/90, effective 7/1/91. Statutory Authority: RCW 19.27A.020 and 1990 c 2.
- 51-12-409 Section 409. Simultaneous heating and cooling. [Statutory Authority: 1985 c 144. 85-24-028 (Order 85-14), § 51-12-409, filed 11/26/85.] Repealed by 91-01-112, filed 12/19/90, effective 7/1/91. Statutory Authority: RCW 19.27A.020 and 1990 c 2.
- 51-12-410 Section 410. Energy recovery. [Statutory Authority: 1985 c 144. 85-24-028 (Order 85-14), § 51-12-410, filed 11/26/85.] Repealed by 91-01-112, filed 12/19/90, effective 7/1/91. Statutory Authority: RCW 19.27A.020 and 1990 c 2.
- 51-12-411 Section 411. HVAC equipment performance requirements. [Statutory Authority: RCW 19.27.074, 19.27A.010 and 19.27A.020. 89-04-043 (Order 88-10), § 51-12-411, filed 1/31/89, effective 7/1/89. Statutory Authority: RCW 19.27A.020 and chapter 19.27A RCW. 86-11-013 (Order 86-04), § 51-12-411, filed 5/13/86. Statutory Authority: 1985 c 144. 85-24-028 (Order 85-14), § 51-12-411, filed 11/26/85.] Repealed by 91-01-112, filed 12/19/90, effective 7/1/91. Statutory Authority: RCW 19.27A.020 and 1990 c 2.
- 51-12-412 Section 412. Energy for air delivery. [Statutory Authority: 1985 c 144. 85-24-028 (Order 85-14), § 51-12-412, filed 11/26/85.] Repealed by 91-01-112, filed 12/19/90, effective 7/1/91. Statutory Authority: RCW 19.27A.020 and 1990 c 2.
- 51-12-413 Section 413. Balancing. [Statutory Authority: 1985 c 144. 85-24-028 (Order 85-14), § 51-12-413, filed 11/26/85.] Repealed by 91-01-112, filed 12/19/90, effective 7/1/91. Statutory Authority: RCW 19.27A.020 and 1990 c 2.
- 51-12-414 Section 414. Cooling with outdoor air (economizer cycle). [Statutory Authority: 1985 c 144. 85-24-028 (Order 85-14), § 51-12-414, filed 11/26/85.] Repealed by 91-01-112, filed 12/19/90, effective 7/1/91. Statutory Authority: RCW 19.27A.020 and 1990 c 2.
- 51-12-415 Section 415. Controls. [Statutory Authority: 1985 c 144. 85-24-028 (Order 85-14), § 51-12-415, filed 11/26/85.] Repealed by 91-01-112, filed 12/19/90, effective 7/1/91. Statutory Authority: RCW 19.27A.020 and 1990 c 2.
- 51-12-416 Section 416. Air handling duct system insulation. [Statutory Authority: 1985 c 144. 85-24-028 (Order 85-14), § 51-12-416, filed 11/26/85.] Repealed by 91-01-112, filed 12/19/90, effective 7/1/91. Statutory Authority: RCW 19.27A.020 and 1990 c 2.
- 51-12-417 Section 417. Duct construction. [Statutory Authority: 1985 c 144. 85-24-028 (Order 85-14), § 51-12-417, filed 11/26/85.] Repealed by 91-01-112, filed 12/19/90, effective 7/1/91. Statutory Authority: RCW 19.27A.020 and 1990 c 2.
- 51-12-418 Section 418. Piping insulation. [Statutory Authority: 1985 c 144. 85-24-028 (Order 85-14), § 51-12-418, filed 11/26/85.] Repealed by 91-01-112, filed 12/19/90, effective 7/1/91. Statutory Authority: RCW 19.27A.020 and 1990 c 2.
- 51-12-419 Section 419. (Reserved). [Statutory Authority: 1985 c 144. 85-24-028 (Order 85-14), § 51-12-419, filed 11/26/85.] Repealed by 91-01-112, filed 12/19/90, effective 7/1/91. Statutory Authority: RCW 19.27A.020 and 1990 c 2.
- 51-12-420 Section 420. Water heaters, storage tanks, boilers, and piping. [Statutory Authority: 1985 c 144. 85-24-028 (Order 85-14), § 51-12-420, filed 11/26/85.] Repealed by 91-01-112, filed 12/19/90, effective 7/1/91. Statutory Authority: RCW 19.27A.020 and 1990 c 2.
- 51-12-421 Section 421. Pump operation. [Statutory Authority: 1985 c 144. 85-24-028 (Order 85-14), § 51-12-421, filed 11/26/85.] Repealed by 91-01-112, filed 12/19/90, effective 7/1/91. Statutory Authority: RCW 19.27A.020 and 1990 c 2.
- 51-12-422 Section 422. Pipe insulation. [Statutory Authority: 1985 c 144. 85-24-028 (Order 85-14), § 51-12-422, filed 11/26/85.] Repealed by 91-01-112, filed 12/19/90, effective 7/1/91. Statutory Authority: RCW 19.27A.020 and 1990 c 2.
- 51-12-423 Section 423. Conservation of hot water. [Statutory Authority: 1985 c 144. 85-24-028 (Order 85-14), § 51-12-423, filed 11/26/85.] Repealed by 91-01-112, filed 12/19/90, effective 7/1/91. Statutory Authority: RCW 19.27A.020 and 1990 c 2.
- 51-12-424 Section 424. Electrical power and lighting. [Statutory Authority: 1985 c 144. 85-24-028 (Order 85-14), § 51-12-424, filed 11/26/85.] Repealed by 91-01-112, filed 12/19/90, effective 7/1/91. Statutory Authority: RCW 19.27A.020 and 1990 c 2.
- 51-12-425 Section 425. Lighting switching. [Statutory Authority: 1985 c 144. 85-24-028 (Order 85-14), § 51-12-425, filed 11/26/85.] Repealed by 91-01-112, filed 12/19/90, effective 7/1/91. Statutory Authority: RCW 19.27A.020 and 1990 c 2.
- 51-12-426 Section 426. Lighting power budget. [Statutory Authority: Chapters 19.27, 19.27A and 70.92 RCW, and 1989 c 266. 90-02-110, § 51-12-426, filed 1/3/90, effective 7/1/90. Statutory Authority: RCW 19.27.074, 19.27A.010 and 19.27A.020. 89-04-043 (Order 88-10), § 51-12-426, filed 1/31/89, effective 7/1/89. Statutory Authority: RCW 19.27A.020 and chapter 19.27A RCW. 86-20-024 (Resolution No. 86-17), § 51-12-426, filed 9/23/86; 86-11-013 (Order 86-04), § 51-12-426, filed 5/13/86. Statutory Authority: 1985 c 144. 85-24-028 (Order 85-14), § 51-12-426, filed 11/26/85.] Repealed by 91-01-112, filed 12/19/90, effective 7/1/91. Statutory Authority: RCW 19.27A.020 and 1990 c 2.
- 51-12-500 Section 500. General. [Statutory Authority: 1985 c 144. 85-24-028 (Order 85-14), § 51-12-500, filed 11/26/85.] Repealed by 91-01-112, filed 12/19/90, effective 7/1/91. Statutory Authority: RCW 19.27A.020 and 1990 c 2.
- 51-12-501 Section 501. Energy analysis. [Statutory Authority: 1985 c 144. 85-24-028 (Order 85-14), § 51-12-501, filed 11/26/85.] Repealed by 91-01-112, filed 12/19/90, effective 7/1/91. Statutory Authority: RCW 19.27A.020 and 1990 c 2.
- 51-12-502 Section 502. Design. [Statutory Authority: 1985 c 144. 85-24-028 (Order 85-14), § 51-12-502, filed 11/26/85.] Repealed by 91-01-112, filed 12/19/90, effective 7/1/91. Statutory Authority: RCW 19.27A.020 and 1990 c 2.
- 51-12-503 Section 503. Analysis procedure. [Statutory Authority: RCW 19.27.074, 19.27A.010 and 19.27A.020. 89-04-043 (Order 88-10), § 51-12-503, filed 1/31/89, effective 7/1/89. Statutory Authority: 1985 c 144. 85-24-028 (Order 85-14), § 51-12-503, filed 11/26/85.] Repealed by 91-01-112, filed 12/19/90, effective 7/1/91. Statutory Authority: RCW 19.27A.020 and 1990 c 2.
- 51-12-504 Section 504. Calculation procedure. [Statutory Authority: 1985 c 144. 85-24-028 (Order 85-14), § 51-12-504, filed 11/26/85.] Repealed by 91-01-112, filed 12/19/90, effective 7/1/91. Statutory Authority: RCW 19.27A.020 and 1990 c 2.
- 51-12-505 Section 505. Documentation. [Statutory Authority: 1985 c 144. 85-24-028 (Order 85-14), § 51-12-505, filed 11/26/85.] Repealed by 91-01-112, filed 12/19/90, effective 7/1/91. Statutory Authority: RCW 19.27A.020 and 1990 c 2.
- 51-12-506 Section 506. Buildings utilizing nondepletable energy. [Statutory Authority: 1985 c 144. 85-24-028 (Order 85-14), § 51-12-506, filed 11/26/85.] Repealed by 91-01-112, filed 12/19/90, effective 7/1/91. Statutory Authority: RCW 19.27A.020 and 1990 c 2.
- 51-12-507 Section 507. Documentation—buildings using nondepletable energy sources. [Statutory Authority: 1985 c 144. 85-24-028 (Order 85-14), § 51-12-507, filed 11/26/85.] Repealed by 91-01-112, filed 12/19/90, effective 7/1/91. Statutory Authority: RCW 19.27A.020 and 1990 c 2.
- 51-12-600 Section 600. General. [Statutory Authority: 1985 c 144. 85-24-028 (Order 85-14), § 51-12-600, filed 11/26/85.]

51-12-601	Repealed by 91-01-112, filed 12/19/90, effective 7/1/91. Statutory Authority: RCW 19.27A.020 and 1990 c 2. Section 601. Low-rise residential building envelope requirements. [Statutory Authority: Chapters 19.27, 19.27A and 70.92 RCW, and 1989 c 266. 90-02-110, § 51-12-601, filed 1/31/89, effective 7/1/90. Statutory Authority: RCW 19.27.074, 19.27A.010 and 19.27A.020. 89-04-043 (Order 88-10), § 51-12-601, filed 1/31/89, effective 7/1/89. Statutory Authority: RCW 19.27A.020 and chapter 19.27A RCW. 86-20-024 (Resolution No. 86-17), § 51-12-601, filed 9/23/86; 86-11-013 (Order 86-04), § 51-12-601, filed 5/13/86. Statutory Authority: 1985 c 144. 85-24-028 (Order 85-14), § 51-12-601, filed 11/26/85.] Repealed by 91-01-112, filed 12/19/90, effective 7/1/91. Statutory Authority: RCW 19.27A.020 and 1990 c 2.	51-18-030	Water efficiency standards. [Statutory Authority: Chapters 19.27, 19.27A and 70.92 RCW, and 1989 c 266. 90-02-110, § 51-18-030, filed 1/3/90, effective 7/1/90.] Repealed by 92-01-068, filed 12/13/91, effective 7/1/92. Statutory Authority: RCW 19.27.170 and chapter 19.27 RCW.
51-12-602	Section 602. Low-rise residential building mechanical systems. [Statutory Authority: RCW 19.27.074, 19.27A.010 and 19.27A.020. 89-04-043 (Order 88-10), § 51-12-602, filed 1/31/89, effective 7/1/89. Statutory Authority: RCW 19.27A.020 and chapter 19.27A RCW. 86-11-013 (Order 86-04), § 51-12-602, filed 5/13/86; 85-24-028 (Order 85-14), § 51-12-602, filed 11/26/85.] Repealed by 91-01-112, filed 12/19/90, effective 7/1/91. Statutory Authority: RCW 19.27A.020 and 1990 c 2.	51-18-040	Exceptions. [Statutory Authority: Chapters 19.27, 19.27A and 70.92 RCW, and 1989 c 266. 90-02-110, § 51-18-040, filed 1/3/90, effective 7/1/90.] Repealed by 92-01-068, filed 12/13/91, effective 7/1/92. Statutory Authority: RCW 19.27.170 and chapter 19.27 RCW.
51-12-603	Section 603. Low-rise residential building service water heating. [Statutory Authority: 1985 c 144. 85-24-028 (Order 85-14), § 51-12-603, filed 11/26/85.] Repealed by 91-01-112, filed 12/19/90, effective 7/1/91. Statutory Authority: RCW 19.27A.020 and 1990 c 2.	51-18-050	Implementation. [Statutory Authority: Chapters 19.27, 19.27A and 70.92 RCW, and 1989 c 266. 90-02-110, § 51-18-050, filed 1/3/90, effective 7/1/90.] Repealed by 92-01-068, filed 12/13/91, effective 7/1/92. Statutory Authority: RCW 19.27.170 and chapter 19.27 RCW.
51-12-604	Section 604. Low-rise residential building electrical power and lighting. [Statutory Authority: 1985 c 144. 85-24-028 (Order 85-14), § 51-12-604, filed 11/26/85.] Repealed by 91-01-112, filed 12/19/90, effective 7/1/91. Statutory Authority: RCW 19.27A.020 and 1990 c 2.	Chapter 51-20 STATE BUILDING CODE ADOPTION AND AMENDMENT OF THE 1991 EDITION OF THE UNIFORM BUILDING CODE (Replaced by chapter 51-30 WAC)	
51-12-605	Section 605. Building envelope requirements for other than low-rise residential buildings. [Statutory Authority: RCW 19.27.074, 19.27A.010 and 19.27A.020. 89-04-043 (Order 88-10), § 51-12-605, filed 1/31/89, effective 7/1/89. Statutory Authority: 1985 c 144. 85-24-028 (Order 85-14), § 51-12-605, filed 11/26/85.] Repealed by 91-01-112, filed 12/19/90, effective 7/1/91. Statutory Authority: RCW 19.27A.020 and 1990 c 2.	51-20-001	Authority. [Statutory Authority: Chapters 70.92 and 19.27 RCW. 92-01-145, § 51-20-001, filed 12/19/91, effective 7/1/92.] Repealed by 95-11-107, filed 5/23/95, effective 6/30/95. Statutory Authority: RCW 19.27.074, 19.27.020, 19.27.031 and chapter 34.05 RCW.
51-12-606	Section 606. Building mechanical systems requirements for other than low-rise residential buildings. [Statutory Authority: 1985 c 144. 85-24-028 (Order 85-14), § 51-12-606, filed 11/26/85.] Repealed by 91-01-112, filed 12/19/90, effective 7/1/91. Statutory Authority: RCW 19.27A.020 and 1990 c 2.	51-20-002	Purpose. [Statutory Authority: Chapters 70.92 and 19.27 RCW. 92-01-145, § 51-20-002, filed 12/19/91, effective 7/1/92.] Repealed by 95-11-107, filed 5/23/95, effective 6/30/95. Statutory Authority: RCW 19.27.074, 19.27.020, 19.27.031 and chapter 34.05 RCW.
51-12-607	Section 607. Service water heating requirement for other than low-rise residential buildings. [Statutory Authority: 1985 c 144. 85-24-028 (Order 85-14), § 51-12-607, filed 11/26/85.] Repealed by 91-01-112, filed 12/19/90, effective 7/1/91. Statutory Authority: RCW 19.27A.020 and 1990 c 2.	51-20-003	Uniform Building Code. [Statutory Authority: Chapters 70.92 and 19.27 RCW. 92-01-145, § 51-20-003, filed 12/19/91, effective 7/1/92.] Repealed by 95-11-107, filed 5/23/95, effective 6/30/95. Statutory Authority: RCW 19.27.074, 19.27.020, 19.27.031 and chapter 34.05 RCW.
51-12-608	Section 608. Electrical power and lighting requirements for other than low-rise residential buildings. [Statutory Authority: Chapters 19.27, 19.27A and 70.92 RCW, and 1989 c 266. 90-02-110, § 51-12-608, filed 1/3/90, effective 7/1/90. Statutory Authority: RCW 19.27.074, 19.27A.010 and 19.27A.020. 89-04-043 (Order 88-10), § 51-12-608, filed 1/31/89, effective 7/1/89. Statutory Authority: RCW 19.27A.020 and chapter 19.27A RCW. 86-11-013 (Order 86-04), § 51-12-608, filed 5/13/86. Statutory Authority: 1985 c 144. 85-24-028 (Order 85-14), § 51-12-608, filed 11/26/85.] Repealed by 91-01-112, filed 12/19/90, effective 7/1/91. Statutory Authority: RCW 19.27A.020 and 1990 c 2.	51-20-004	Conflicts with Washington State Ventilation and Indoor Air Quality Code. [Statutory Authority: Chapters 70.92 and 19.27 RCW. 92-01-145, § 51-20-004, filed 12/19/91, effective 7/1/92.] Repealed by 95-11-107, filed 5/23/95, effective 6/30/95. Statutory Authority: RCW 19.27.074, 19.27.020, 19.27.031 and chapter 34.05 RCW.
	Chapter 51-18 WASHINGTON STATE WATER CONSERVATION PERFORMANCE STANDARDS	51-20-005	Uniform Building Code requirements for barrier-free accessibility. [Statutory Authority: Chapters 70.92 and 19.27 RCW. 92-01-145, § 51-20-005, filed 12/19/91, effective 7/1/92.] Repealed by 95-11-107, filed 5/23/95, effective 6/30/95. Statutory Authority: RCW 19.27.074, 19.27.020, 19.27.031 and chapter 34.05 RCW.
51-18-010	Declaration of purpose. [Statutory Authority: Chapters 19.27, 19.27A and 70.92 RCW, and 1989 c 266. 90-02-110, § 51-18-010, filed 1/3/90, effective 7/1/90.] Repealed by 92-01-068, filed 12/13/91, effective 7/1/92. Statutory Authority: RCW 19.27.170 and chapter 19.27 RCW.	51-20-007	Exceptions. [Statutory Authority: Chapters 70.92 and 19.27 RCW. 92-01-145, § 51-20-007, filed 12/19/91, effective 7/1/92.] Repealed by 95-11-107, filed 5/23/95, effective 6/30/95. Statutory Authority: RCW 19.27.074, 19.27.020, 19.27.031 and chapter 34.05 RCW.
51-18-020	Application. [Statutory Authority: Chapters 19.27, 19.27A and 70.92 RCW, and 1989 c 266. 90-02-110, § 51-18-020, filed 1/3/90, effective 7/1/90.] Repealed by 92-01-068, filed 12/13/91, effective 7/1/92. Statutory Authority: RCW 19.27.170 and chapter 19.27 RCW.	51-20-008	Implementation. [Statutory Authority: Chapters 70.92 and 19.27 RCW. 92-01-145, § 51-20-008, filed 12/19/91, effective 7/1/92.] Repealed by 95-11-107, filed 5/23/95, effective 6/30/95. Statutory Authority: RCW 19.27.074, 19.27.020, 19.27.031 and chapter 34.05 RCW.
		51-20-009	Recyclable materials and solid waste storage. [Statutory Authority: Chapters 70.92 and 19.27 RCW. 92-01-145, § 51-20-009, filed 12/19/91, effective 7/1/92.] Repealed by 95-11-107, filed 5/23/95, effective 6/30/95. Statutory Authority: RCW 19.27.074, 19.27.020, 19.27.031 and chapter 34.05 RCW.
		51-20-0100	Chapter 1. [Statutory Authority: Chapters 70.92 and 19.27 RCW. 92-01-145, § 51-20-0100, filed 12/19/91, effective 7/1/92.] Repealed by 95-11-107, filed 5/23/95, effective 6/30/95. Statutory Authority: RCW 19.27.074, 19.27.020, 19.27.031 and chapter 34.05 RCW.
		51-20-0104	Application to existing buildings and structures. [Statutory Authority: Chapters 70.92 and 19.27 RCW. 92-01-145, § 51-20-0104, filed 12/19/91, effective 7/1/92.] Repealed by 95-11-107, filed 5/23/95, effective 6/30/95. Statutory Authority: RCW 19.27.074, 19.27.020, 19.27.031 and chapter 34.05 RCW.

	Authority: RCW 19.27.074, 19.27.020, 19.27.031 and chapter 34.05 RCW.		filed 5/23/95, effective 6/30/95. Statutory Authority: RCW 19.27.074, 19.27.020, 19.27.031 and chapter 34.05 RCW.
51-20-1210	Smoke detectors and sprinkler systems. [Statutory Authority: Chapters 70.92 and 19.27 RCW. 92-01-145, § 51-20-1210, filed 12/19/91, effective 7/1/92.] Repealed by 95-11-107, filed 5/23/95, effective 6/30/95. Statutory Authority: RCW 19.27.074, 19.27.020, 19.27.031 and chapter 34.05 RCW.	51-20-1800	Chapter 18. [Statutory Authority: Chapters 70.92 and 19.27 RCW. 92-01-145, § 51-20-1800, filed 12/19/91, effective 7/1/92.] Repealed by 95-11-107, filed 5/23/95, effective 6/30/95. Statutory Authority: RCW 19.27.074, 19.27.020, 19.27.031 and chapter 34.05 RCW.
51-20-1215	Family child day care homes. [Statutory Authority: Chapters 70.92 and 19.27 RCW. 92-01-145, § 51-20-1215, filed 12/19/91, effective 7/1/92.] Repealed by 95-11-107, filed 5/23/95, effective 6/30/95. Statutory Authority: RCW 19.27.074, 19.27.020, 19.27.031 and chapter 34.05 RCW.	51-20-1807	Special provisions for Group B, Division 2 office buildings and Group R, Division 1 Occupancies. [Statutory Authority: Chapters 70.92 and 19.27 RCW. 92-01-145, § 51-20-1807, filed 12/19/91, effective 7/1/92.] Repealed by 95-11-107, filed 5/23/95, effective 6/30/95. Statutory Authority: RCW 19.27.074, 19.27.020, 19.27.031 and chapter 34.05 RCW.
51-20-1223	Division II. Requirements for Group R, Division 4 and Division 5 Occupancies. [Statutory Authority: Chapters 70.92 and 19.27 RCW. 92-01-145, § 51-20-1223, filed 12/19/91, effective 7/1/92.] Repealed by 95-11-107, filed 5/23/95, effective 6/30/95. Statutory Authority: RCW 19.27.074, 19.27.020, 19.27.031 and chapter 34.05 RCW.	51-20-2300	General design requirements. [Statutory Authority: Chapters 70.92 and 19.27 RCW. 92-01-145, § 51-20-2300, filed 12/19/91, effective 7/1/92.] Repealed by 95-11-107, filed 5/23/95, effective 6/30/95. Statutory Authority: RCW 19.27.074, 19.27.020, 19.27.031 and chapter 34.05 RCW.
51-20-1224	Construction, height and allowable area. [Statutory Authority: Chapters 70.92 and 19.27 RCW. 92-01-145, § 51-20-1224, filed 12/19/91, effective 7/1/92.] Repealed by 95-11-107, filed 5/23/95, effective 6/30/95. Statutory Authority: RCW 19.27.074, 19.27.020, 19.27.031 and chapter 34.05 RCW.	51-20-2312	Definitions for wind design. [Statutory Authority: Chapters 70.92 and 19.27 RCW. 92-01-145, § 51-20-2312, filed 12/19/91, effective 7/1/92.] Repealed by 95-11-107, filed 5/23/95, effective 6/30/95. Statutory Authority: RCW 19.27.074, 19.27.020, 19.27.031 and chapter 34.05 RCW.
51-20-1225	Location on property. [Statutory Authority: Chapters 70.92 and 19.27 RCW. 92-01-145, § 51-20-1225, filed 12/19/91, effective 7/1/92.] Repealed by 95-11-107, filed 5/23/95, effective 6/30/95. Statutory Authority: RCW 19.27.074, 19.27.020, 19.27.031 and chapter 34.05 RCW.	51-20-2700	Chapter 27. [Statutory Authority: Chapters 70.92 and 19.27 RCW. 92-01-145, § 51-20-2700, filed 12/19/91, effective 7/1/92.] Repealed by 95-11-107, filed 5/23/95, effective 6/30/95. Statutory Authority: RCW 19.27.074, 19.27.020, 19.27.031 and chapter 34.05 RCW.
51-20-1226	Exits and emergency escapes. [Statutory Authority: Chapters 70.92 and 19.27 RCW. 92-01-145, § 51-20-1226, filed 12/19/91, effective 7/1/92.] Repealed by 95-11-107, filed 5/23/95, effective 6/30/95. Statutory Authority: RCW 19.27.074, 19.27.020, 19.27.031 and chapter 34.05 RCW.	51-20-2710	Steel structures resisting forces induced by earthquake motions in Seismic Zones Nos. 3 and 4. [Statutory Authority: Chapters 70.92 and 19.27 RCW. 92-01-145, § 51-20-2710, filed 12/19/91, effective 7/1/92.] Repealed by 95-11-107, filed 5/23/95, effective 6/30/95. Statutory Authority: RCW 19.27.074, 19.27.020, 19.27.031 and chapter 34.05 RCW.
51-20-1227	Light, ventilation and sanitation. [Statutory Authority: Chapters 70.92 and 19.27 RCW. 92-01-145, § 51-20-1227, filed 12/19/91, effective 7/1/92.] Repealed by 95-11-107, filed 5/23/95, effective 6/30/95. Statutory Authority: RCW 19.27.074, 19.27.020, 19.27.031 and chapter 34.05 RCW.	51-20-3000	Chapter 30—Veneer. [Statutory Authority: Chapters 70.92 and 19.27 RCW. 92-01-145, § 51-20-3000, filed 12/19/91, effective 7/1/92.] Repealed by 95-11-107, filed 5/23/95, effective 6/30/95. Statutory Authority: RCW 19.27.074, 19.27.020, 19.27.031 and chapter 34.05 RCW.
51-20-1228	Yards and courts. [Statutory Authority: Chapters 70.92 and 19.27 RCW. 92-01-145, § 51-20-1228, filed 12/19/91, effective 7/1/92.] Repealed by 95-11-107, filed 5/23/95, effective 6/30/95. Statutory Authority: RCW 19.27.074, 19.27.020, 19.27.031 and chapter 34.05 RCW.	51-20-3007	Plastic veneer. [Statutory Authority: Chapters 70.92 and 19.27 RCW. 92-01-145, § 51-20-3007, filed 12/19/91, effective 7/1/92.] Repealed by 95-11-107, filed 5/23/95, effective 6/30/95. Statutory Authority: RCW 19.27.074, 19.27.020, 19.27.031 and chapter 34.05 RCW.
51-20-1229	Room dimensions. [Statutory Authority: Chapters 70.92 and 19.27 RCW. 92-01-145, § 51-20-1229, filed 12/19/91, effective 7/1/92.] Repealed by 95-11-107, filed 5/23/95, effective 6/30/95. Statutory Authority: RCW 19.27.074, 19.27.020, 19.27.031 and chapter 34.05 RCW.	51-20-3100	Chapter 31—Accessibility. [Statutory Authority: Chapters 70.92 and 19.27 RCW. 92-01-145, § 51-20-3100, filed 12/19/91, effective 7/1/92.] Repealed by 95-11-107, filed 5/23/95, effective 6/30/95. Statutory Authority: RCW 19.27.074, 19.27.020, 19.27.031 and chapter 34.05 RCW.
51-20-1230	Section 1230. [Statutory Authority: Chapters 70.92 and 19.27 RCW. 92-01-145, § 51-20-1230, filed 12/19/91, effective 7/1/92.] Repealed by 95-11-107, filed 5/23/95, effective 6/30/95. Statutory Authority: RCW 19.27.074, 19.27.020, 19.27.031 and chapter 34.05 RCW.	51-20-3101	Scope. [Statutory Authority: Chapters 70.92 and 19.27 RCW. 92-01-145, § 51-20-3101, filed 12/19/91, effective 7/1/92.] Repealed by 95-11-107, filed 5/23/95, effective 6/30/95. Statutory Authority: RCW 19.27.074, 19.27.020, 19.27.031 and chapter 34.05 RCW.
51-20-1231	Shaft enclosures. [Statutory Authority: Chapters 70.92 and 19.27 RCW. 92-01-145, § 51-20-1231, filed 12/19/91, effective 7/1/92.] Repealed by 95-11-107, filed 5/23/95, effective 6/30/95. Statutory Authority: RCW 19.27.074, 19.27.020, 19.27.031 and chapter 34.05 RCW.	51-20-3102	Definitions. [Statutory Authority: RCW 19.27.074 and 70.92.140. 93-01-166, § 51-20-3102, filed 12/23/92, effective 7/1/93. Statutory Authority: Chapters 70.92 and 19.27 RCW. 92-01-145, § 51-20-3102, filed 12/19/91, effective 7/1/92.] Repealed by 95-11-107, filed 5/23/95, effective 6/30/95. Statutory Authority: RCW 19.27.074, 19.27.020, 19.27.031 and chapter 34.05 RCW.
51-20-1232	Fire alarm systems. [Statutory Authority: Chapters 70.92 and 19.27 RCW. 92-01-145, § 51-20-1232, filed 12/19/91, effective 7/1/92.] Repealed by 95-11-107, filed 5/23/95, effective 6/30/95. Statutory Authority: RCW 19.27.074, 19.27.020, 19.27.031 and chapter 34.05 RCW.	51-20-3103	Building accessibility. [Statutory Authority: RCW 19.27.074 and 70.92.140. 93-01-166, § 51-20-3103, filed 12/23/92, effective 7/1/93. Statutory Authority: Chapters 70.92 and 19.27 RCW. 92-01-145, § 51-20-3103, filed 12/19/91, effective 7/1/92.] Repealed by 95-11-107, filed 5/23/95, effective 6/30/95. Statutory Authority: RCW 19.27.074, 19.27.020, 19.27.031 and chapter 34.05 RCW.
51-20-1233	Heating. [Statutory Authority: Chapters 70.92 and 19.27 RCW. 92-01-145, § 51-20-1233, filed 12/19/91, effective 7/1/92.] Repealed by 95-11-107, filed 5/23/95, effective 6/30/95. Statutory Authority: RCW 19.27.074, 19.27.020, 19.27.031 and chapter 34.05 RCW.	51-20-3104	Egress and areas for evacuation assistance. [Statutory Authority: RCW 19.27.074 and 70.92.140. 93-01-166, § 51-20-3104, filed 12/23/92, effective 7/1/93. Statutory
51-20-1234	Special hazards. [Statutory Authority: Chapters 70.92 and 19.27 RCW. 92-01-145, § 51-20-1234, filed 12/19/91, effective 7/1/92.] Repealed by 95-11-107,		

- Statutory Authority: RCW 19.27.074, 19.27.020, 19.27.031 and chapter 34.05 RCW.
- 51-20-3900 Chapter 39. [Statutory Authority: Chapters 70.92 and 19.27 RCW. 92-01-145, § 51-20-3900, filed 12/19/91, effective 7/1/92.] Repealed by 95-11-107, filed 5/23/95, effective 6/30/95. Statutory Authority: RCW 19.27.074, 19.27.020, 19.27.031 and chapter 34.05 RCW.
- 51-20-3901 Scope. [Statutory Authority: Chapters 70.92 and 19.27 RCW. 92-01-145, § 51-20-3901, filed 12/19/91, effective 7/1/92.] Repealed by 95-11-107, filed 5/23/95, effective 6/30/95. Statutory Authority: RCW 19.27.074, 19.27.020, 19.27.031 and chapter 34.05 RCW.
- 51-20-3903 Stages. [Statutory Authority: Chapters 70.92 and 19.27 RCW. 92-01-145, § 51-20-3903, filed 12/19/91, effective 7/1/92.] Repealed by 95-11-107, filed 5/23/95, effective 6/30/95. Statutory Authority: RCW 19.27.074, 19.27.020, 19.27.031 and chapter 34.05 RCW.
- 51-20-5100 Chapter 51. [Statutory Authority: Chapters 70.92 and 19.27 RCW. 92-01-145, § 51-20-5100, filed 12/19/91, effective 7/1/92.] Repealed by 95-11-107, filed 5/23/95, effective 6/30/95. Statutory Authority: RCW 19.27.074, 19.27.020, 19.27.031 and chapter 34.05 RCW.
- 51-20-5103 Delete section 5103, special provisions. [Statutory Authority: Chapters 70.92 and 19.27 RCW. 92-01-145, § 51-20-5103, filed 12/19/91, effective 7/1/92.] Repealed by 95-11-107, filed 5/23/95, effective 6/30/95. Statutory Authority: RCW 19.27.074, 19.27.020, 19.27.031 and chapter 34.05 RCW.
- 51-20-5105 Elevator machine room floors. [Statutory Authority: Chapters 70.92 and 19.27 RCW. 92-01-145, § 51-20-5105, filed 12/19/91, effective 7/1/92.] Repealed by 95-11-107, filed 5/23/95, effective 6/30/95. Statutory Authority: RCW 19.27.074, 19.27.020, 19.27.031 and chapter 34.05 RCW.
- 51-20-5400 Chapter 54. [Statutory Authority: Chapters 70.92 and 19.27 RCW. 92-01-145, § 51-20-5400, filed 12/19/91, effective 7/1/92.] Repealed by 95-11-107, filed 5/23/95, effective 6/30/95. Statutory Authority: RCW 19.27.074, 19.27.020, 19.27.031 and chapter 34.05 RCW.
- 51-20-5401 Scope. [Statutory Authority: Chapters 70.92 and 19.27 RCW. 92-01-145, § 51-20-5401, filed 12/19/91, effective 7/1/92.] Repealed by 95-11-107, filed 5/23/95, effective 6/30/95. Statutory Authority: RCW 19.27.074, 19.27.020, 19.27.031 and chapter 34.05 RCW.
- 51-20-93100 Appendix chapter 31. [Statutory Authority: Chapters 70.92 and 19.27 RCW. 92-01-145, § 51-20-93100, filed 12/19/91, effective 7/1/92.] Repealed by 95-11-107, filed 5/23/95, effective 6/30/95. Statutory Authority: RCW 19.27.074, 19.27.020, 19.27.031 and chapter 34.05 RCW.
- 51-20-93115 Section 3115. [Statutory Authority: Chapters 70.92 and 19.27 RCW. 92-01-145, § 51-20-93115, filed 12/19/91, effective 7/1/92.] Repealed by 95-11-107, filed 5/23/95, effective 6/30/95. Statutory Authority: RCW 19.27.074, 19.27.020, 19.27.031 and chapter 34.05 RCW.
- 51-20-93116 Section 3116. [Statutory Authority: Chapters 70.92 and 19.27 RCW. 92-01-145, § 51-20-93116, filed 12/19/91, effective 7/1/92.] Repealed by 95-11-107, filed 5/23/95, effective 6/30/95. Statutory Authority: RCW 19.27.074, 19.27.020, 19.27.031 and chapter 34.05 RCW.
- 51-20-93117 Section 3117. [Statutory Authority: Chapters 70.92 and 19.27 RCW. 92-01-145, § 51-20-93117, filed 12/19/91, effective 7/1/92.] Repealed by 95-11-107, filed 5/23/95, effective 6/30/95. Statutory Authority: RCW 19.27.074, 19.27.020, 19.27.031 and chapter 34.05 RCW.
- 51-20-93118 Section 3118. [Statutory Authority: Chapters 70.92 and 19.27 RCW. 92-01-145, § 51-20-93118, filed 12/19/91, effective 7/1/92.] Repealed by 95-11-107, filed 5/23/95, effective 6/30/95. Statutory Authority: RCW 19.27.074, 19.27.020, 19.27.031 and chapter 34.05 RCW.
- 51-20-93119 Section 3119. [Statutory Authority: RCW 19.27.074 and 70.92.140, 93-01-166, § 51-20-93119, filed 12/23/92, effective 7/1/93. Statutory Authority: Chapters 70.92 and 19.27 RCW. 92-01-145, § 51-20-93119, filed 12/19/91, effective 7/1/92.] Repealed by 95-11-107, filed 5/23/95, effective 6/30/95. Statutory Authority: RCW 19.27.074, 19.27.020, 19.27.031 and chapter 34.05 RCW.
- 51-20-93120 Section 3120. [Statutory Authority: RCW 19.27.074 and 70.92.140, 93-01-166, § 51-20-93120, filed 12/23/92, effective 7/1/93. Statutory Authority: Chapters 70.92 and 19.27 RCW. 92-01-145, § 51-20-93120, filed 12/19/91, effective 7/1/92.] Repealed by 95-11-107, filed 5/23/95, effective 6/30/95. Statutory Authority: RCW 19.27.074, 19.27.020, 19.27.031 and chapter 34.05 RCW.
- Chapter 51-21**
STATE BUILDING CODE ADOPTION AND AMENDMENT OF
THE 1991 EDITION OF THE UNIFORM BUILDING CODE
STANDARDS
(Replaced by chapter 51-30 WAC)
- 51-21-001 Authority. [Statutory Authority: Chapters 70.92 and 19.27 RCW. 92-01-145, § 51-21-001, filed 12/19/91, effective 7/1/92.] Repealed by 95-11-107, filed 5/23/95, effective 6/30/95. Statutory Authority: RCW 19.27.074, 19.27.020, 19.27.031 and chapter 34.05 RCW.
- 51-21-002 Purpose. [Statutory Authority: Chapters 70.92 and 19.27 RCW. 92-01-145, § 51-21-002, filed 12/19/91, effective 7/1/92.] Repealed by 95-11-107, filed 5/23/95, effective 6/30/95. Statutory Authority: RCW 19.27.074, 19.27.020, 19.27.031 and chapter 34.05 RCW.
- 51-21-003 Uniform Building Code standards. [Statutory Authority: Chapters 70.92 and 19.27 RCW. 92-01-145, § 51-21-003, filed 12/19/91, effective 7/1/92.] Repealed by 95-11-107, filed 5/23/95, effective 6/30/95. Statutory Authority: RCW 19.27.074, 19.27.020, 19.27.031 and chapter 34.05 RCW.
- 51-21-007 Exceptions. [Statutory Authority: Chapters 70.92 and 19.27 RCW. 92-01-145, § 51-21-007, filed 12/19/91, effective 7/1/92.] Repealed by 95-11-107, filed 5/23/95, effective 6/30/95. Statutory Authority: RCW 19.27.074, 19.27.020, 19.27.031 and chapter 34.05 RCW.
- 51-21-008 Implementation. [Statutory Authority: Chapters 70.92 and 19.27 RCW. 92-01-145, § 51-21-008, filed 12/19/91, effective 7/1/92.] Repealed by 95-11-107, filed 5/23/95, effective 6/30/95. Statutory Authority: RCW 19.27.074, 19.27.020, 19.27.031 and chapter 34.05 RCW.
- 51-21-31010 UBC Standards No. 31-1. [Statutory Authority: Chapters 70.92 and 19.27 RCW. 92-01-145, § 51-21-31010, filed 12/19/91, effective 7/1/92.] Repealed by 95-11-107, filed 5/23/95, effective 6/30/95. Statutory Authority: RCW 19.27.074, 19.27.020, 19.27.031 and chapter 34.05 RCW.
- 51-21-38030 UBC Standards No. 38-3. [Statutory Authority: Chapters 70.92 and 19.27 RCW. 92-01-145, § 51-21-38030, filed 12/19/91, effective 7/1/92.] Repealed by 95-11-107, filed 5/23/95, effective 6/30/95. Statutory Authority: RCW 19.27.074, 19.27.020, 19.27.031 and chapter 34.05 RCW.
- 51-21-38038 Table 1-5.1. [Statutory Authority: Chapters 70.92 and 19.27 RCW. 92-01-145, § 51-21-38038, filed 12/19/91, effective 7/1/92.] Repealed by 95-11-107, filed 5/23/95, effective 6/30/95. Statutory Authority: RCW 19.27.074, 19.27.020, 19.27.031 and chapter 34.05 RCW.
- 51-21-38039 Table 1-5.5. [Statutory Authority: Chapters 70.92 and 19.27 RCW. 92-01-145, § 51-21-38039, filed 12/19/91, effective 7/1/92.] Repealed by 95-11-107, filed 5/23/95, effective 6/30/95. Statutory Authority: RCW 19.27.074, 19.27.020, 19.27.031 and chapter 34.05 RCW.
- Chapter 51-22**
STATE BUILDING CODE ADOPTION AND AMENDMENT OF
THE 1991 EDITION OF THE UNIFORM MECHANICAL CODE
(Replaced by chapter 51-32 WAC)
- 51-22-001 Authority. [Statutory Authority: RCW 19.27.074, 19.27.031, 19.27A.070 through 19.27A.100, and chapters 19.27 and 19.27A RCW. 92-01-064, § 51-22-001, filed 12/13/91, effective 7/1/92.] Repealed by 95-11-107, filed 5/23/95, effective 6/30/95. Statutory Authority: RCW 19.27.074, 19.27.020, 19.27.031 and chapter 34.05 RCW.

51-22-002 Purpose. [Statutory Authority: RCW 19.27.074, 19.27.031, 19.27A.070 through 19.27A.100, and chapters 19.27 and 19.27A RCW. 92-01-064, § 51-22-002, filed 12/13/91, effective 7/1/92.] Repealed by 95-11-107, filed 5/23/95, effective 6/30/95. Statutory Authority: RCW 19.27.074, 19.27.020, 19.27.031 and chapter 34.05 RCW.

51-22-003 Uniform Mechanical Code. [Statutory Authority: RCW 19.27.074, 19.27.031, 19.27A.070 through 19.27A.100, and chapters 19.27 and 19.27A RCW. 92-01-064, § 51-22-003, filed 12/13/91, effective 7/1/92.] Repealed by 95-11-107, filed 5/23/95, effective 6/30/95. Statutory Authority: RCW 19.27.074, 19.27.020, 19.27.031 and chapter 34.05 RCW.

51-22-004 Conflict between Uniform Mechanical Code and State Energy Code chapter 51-11 WAC. [Statutory Authority: RCW 19.27.074, 19.27.031, 19.27A.070 through 19.27A.100, and chapters 19.27 and 19.27A RCW. 92-01-064, § 51-22-004, filed 12/13/91, effective 7/1/92.] Repealed by 95-11-107, filed 5/23/95, effective 6/30/95. Statutory Authority: RCW 19.27.074, 19.27.020, 19.27.031 and chapter 34.05 RCW.

51-22-005 Conflict between Uniform Mechanical Code and State Ventilation and Indoor Air Quality Code chapter 51-13 WAC. [Statutory Authority: RCW 19.27.074, 19.27.031, 19.27A.070 through 19.27A.100, and chapters 19.27 and 19.27A RCW. 92-01-064, § 51-22-005, filed 12/13/91, effective 7/1/92.] Repealed by 95-11-107, filed 5/23/95, effective 6/30/95. Statutory Authority: RCW 19.27.074, 19.27.020, 19.27.031 and chapter 34.05 RCW.

51-22-007 Exceptions. [Statutory Authority: RCW 19.27.074, 19.27.031, 19.27A.070 through 19.27A.100, and chapters 19.27 and 19.27A RCW. 92-01-064, § 51-22-007, filed 12/13/91, effective 7/1/92.] Repealed by 95-11-107, filed 5/23/95, effective 6/30/95. Statutory Authority: RCW 19.27.074, 19.27.020, 19.27.031 and chapter 34.05 RCW.

51-22-008 Implementation. [Statutory Authority: RCW 19.27.074, 19.27.031, 19.27A.070 through 19.27A.100, and chapters 19.27 and 19.27A RCW. 92-01-064, § 51-22-008, filed 12/13/91, effective 7/1/92.] Repealed by 95-11-107, filed 5/23/95, effective 6/30/95. Statutory Authority: RCW 19.27.074, 19.27.020, 19.27.031 and chapter 34.05 RCW.

51-22-0400 Chapter 4—Definitions and abbreviations. [Statutory Authority: RCW 19.27.074, 19.27.031, 19.27A.070 through 19.27A.100, and chapters 19.27 and 19.27A RCW. 92-01-064, § 51-22-0400, filed 12/13/91, effective 7/1/92.] Repealed by 95-11-107, filed 5/23/95, effective 6/30/95. Statutory Authority: RCW 19.27.074, 19.27.020, 19.27.031 and chapter 34.05 RCW.

51-22-0423 U. [Statutory Authority: RCW 19.27.074, 19.27.031, 19.27A.070 through 19.27A.100, and chapters 19.27 and 19.27A RCW. 92-01-064, § 51-22-0423, filed 12/13/91, effective 7/1/92.] Repealed by 95-11-107, filed 5/23/95, effective 6/30/95. Statutory Authority: RCW 19.27.074, 19.27.020, 19.27.031 and chapter 34.05 RCW.

51-22-0500 Chapter 5—Equipment—General. [Statutory Authority: RCW 19.27.074, 19.27.031, 19.27A.070 through 19.27A.100, and chapters 19.27 and 19.27A RCW. 92-01-064, § 51-22-0500, filed 12/13/91, effective 7/1/92.] Repealed by 95-11-107, filed 5/23/95, effective 6/30/95. Statutory Authority: RCW 19.27.074, 19.27.020, 19.27.031 and chapter 34.05 RCW.

51-22-0504 Installation. [Statutory Authority: RCW 19.27.074, 19.27.031, 19.27A.070 through 19.27A.100, and chapters 19.27 and 19.27A RCW. 92-01-064, § 51-22-0504, filed 12/13/91, effective 7/1/92.] Repealed by 95-11-107, filed 5/23/95, effective 6/30/95. Statutory Authority: RCW 19.27.074, 19.27.020, 19.27.031 and chapter 34.05 RCW.

51-22-0800 Chapter 8—Vented decorative appliances, floor furnaces, vented wall furnaces, unit heaters and room heaters. [Statutory Authority: RCW 19.27.074, 19.27.031, 19.27A.070 through 19.27A.100, and chapters 19.27 and 19.27A RCW. 92-01-064, § 51-22-0800, filed 12/13/91, effective 7/1/92.] Repealed by 95-11-107, filed 5/23/95, effective 6/30/95. Statutory Authority: RCW 19.27.074, 19.27.020, 19.27.031 and chapter 34.05 RCW.

51-22-0807 Room heaters. [Statutory Authority: RCW 19.27.074, 19.27.031, 19.27A.070 through 19.27A.100, and chapters 19.27 and 19.27A RCW. 92-01-064, § 51-22-0807, filed 12/13/91, effective 7/1/92.] Repealed by 95-11-107, filed 5/23/95, effective 6/30/95. Statutory Authority: RCW 19.27.074, 19.27.020, 19.27.031 and chapter 34.05 RCW.

51-22-1000 Chapter 10—Ducts. [Statutory Authority: RCW 19.27.074, 19.27.031, 19.27A.070 through 19.27A.100, and chapters 19.27 and 19.27A RCW. 92-01-064, § 51-22-1000, filed 12/13/91, effective 7/1/92.] Repealed by 95-11-107, filed 5/23/95, effective 6/30/95. Statutory Authority: RCW 19.27.074, 19.27.020, 19.27.031 and chapter 34.05 RCW.

51-22-1002 Material. [Statutory Authority: RCW 19.27.074, 19.27.031, 19.27A.070 through 19.27A.100, and chapters 19.27 and 19.27A RCW. 92-01-064, § 51-22-1002, filed 12/13/91, effective 7/1/92.] Repealed by 95-11-107, filed 5/23/95, effective 6/30/95. Statutory Authority: RCW 19.27.074, 19.27.020, 19.27.031 and chapter 34.05 RCW.

51-22-1100 Chapter 11—Ventilation systems and product-conveying systems. [Statutory Authority: RCW 19.27.074, 19.27.031, 19.27A.070 through 19.27A.100, and chapters 19.27 and 19.27A RCW. 92-01-064, § 51-22-1100, filed 12/13/91, effective 7/1/92.] Repealed by 95-11-107, filed 5/23/95, effective 6/30/95. Statutory Authority: RCW 19.27.074, 19.27.020, 19.27.031 and chapter 34.05 RCW.

51-22-1104 Environmental air ducts. [Statutory Authority: RCW 19.27.074, 19.27.031, 19.27A.070 through 19.27A.100, and chapters 19.27 and 19.27A RCW. 92-01-064, § 51-22-1104, filed 12/13/91, effective 7/1/92.] Repealed by 95-11-107, filed 5/23/95, effective 6/30/95. Statutory Authority: RCW 19.27.074, 19.27.020, 19.27.031 and chapter 34.05 RCW.

51-22-1500 Chapter 15—Mechanical refrigerating equipment. [Statutory Authority: RCW 19.27.074, 19.27.031, 19.27A.070 through 19.27A.100, and chapters 19.27 and 19.27A RCW. 92-01-064, § 51-22-1500, filed 12/13/91, effective 7/1/92.] Repealed by 95-11-107, filed 5/23/95, effective 6/30/95. Statutory Authority: RCW 19.27.074, 19.27.020, 19.27.031 and chapter 34.05 RCW.

51-22-1508 Refrigeration machinery room ventilation. [Statutory Authority: RCW 19.27.074, 19.27.031, 19.27A.070 through 19.27A.100, and chapters 19.27 and 19.27A RCW. 92-01-064, § 51-22-1508, filed 12/13/91, effective 7/1/92.] Repealed by 95-11-107, filed 5/23/95, effective 6/30/95. Statutory Authority: RCW 19.27.074, 19.27.020, 19.27.031 and chapter 34.05 RCW.

51-22-1900 Chapter 19—Miscellaneous heat-producing appliances. [Statutory Authority: RCW 19.27.074, 19.27.031, 19.27A.070 through 19.27A.100, and chapters 19.27 and 19.27A RCW. 92-01-064, § 51-22-1900, filed 12/13/91, effective 7/1/92.] Repealed by 95-11-107, filed 5/23/95, effective 6/30/95. Statutory Authority: RCW 19.27.074, 19.27.020, 19.27.031 and chapter 34.05 RCW.

51-22-1903 Clothes dryers. [Statutory Authority: RCW 19.27.074, 19.27.031, 19.27A.070 through 19.27A.100, and chapters 19.27 and 19.27A RCW. 92-01-064, § 51-22-1903, filed 12/13/91, effective 7/1/92.] Repealed by 95-11-107, filed 5/23/95, effective 6/30/95. Statutory Authority: RCW 19.27.074, 19.27.020, 19.27.031 and chapter 34.05 RCW.

**Chapter 51-24
STATE BUILDING CODE ADOPTION AND AMENDMENT OF
THE 1991 EDITION OF THE UNIFORM FIRE CODE
(Replaced by chapter 51-34 WAC)**

51-24-001 Authority. [Statutory Authority: RCW 19.27.074, 19.27.031 and chapter 19.27 RCW. 92-01-065, § 51-24-001, filed 12/13/91, effective 7/1/92.] Repealed by 95-11-107, filed 5/23/95, effective 6/30/95. Statutory Authority: RCW 19.27.074, 19.27.020, 19.27.031 and chapter 34.05 RCW.

51-24-002 Purpose. [Statutory Authority: RCW 19.27.074, 19.27.031 and chapter 19.27 RCW. 92-01-065, § 51-24-002, filed 12/13/91, effective 7/1/92.] Repealed by 95-11-107, filed 5/23/95, effective 6/30/95. Statutory Authority: RCW 19.27.074, 19.27.020, 19.27.031 and chapter 34.05 RCW.

51-24-003	Uniform Fire Code. [Statutory Authority: RCW 19.27.074, 19.27.031 and chapter 19.27 RCW. 92-01-065, § 51-24-003, filed 12/13/91, effective 7/1/92.] Repealed by 95-11-107, filed 5/23/95, effective 6/30/95. Statutory Authority: RCW 19.27.074, 19.27.020, 19.27.031 and chapter 34.05 RCW.	
51-24-007	Exceptions. [Statutory Authority: RCW 19.27.074, 19.27.031 and chapter 19.27 RCW. 92-01-065, § 51-24-007, filed 12/13/91, effective 7/1/92.] Repealed by 95-11-107, filed 5/23/95, effective 6/30/95. Statutory Authority: RCW 19.27.074, 19.27.031 and chapter 34.05 RCW.	51-24-25107 Aisles. Section 25.107. [Statutory Authority: RCW 19.27.074, 19.27.031 and chapter 19.27 RCW. 92-01-065, § 51-24-25107, filed 12/13/91, effective 7/1/92.] Repealed by 95-11-107, filed 5/23/95, effective 6/30/95. Statutory Authority: RCW 19.27.074, 19.27.020, 19.27.031 and chapter 34.05 RCW.
51-24-008	Implementation. [Statutory Authority: RCW 19.27.074, 19.27.031 and chapter 19.27 RCW. 92-01-065, § 51-24-008, filed 12/13/91, effective 7/1/92.] Repealed by 95-11-107, filed 5/23/95, effective 6/30/95. Statutory Authority: RCW 19.27.074, 19.27.020, 19.27.031 and chapter 34.05 RCW.	51-24-45000 Article 45. Application of flammable finishes. [Statutory Authority: RCW 19.27.074, 19.27.031 and chapter 19.27 RCW. 92-01-065, § 51-24-45000, filed 12/13/91, effective 7/1/92.] Repealed by 95-11-107, filed 5/23/95, effective 6/30/95. Statutory Authority: RCW 19.27.074, 19.27.020, 19.27.031 and chapter 34.05 RCW.
51-24-04000	Article 4. Permits. [Statutory Authority: RCW 19.27.074, 19.27.031 and chapter 19.27 RCW. 92-01-065, § 51-24-04000, filed 12/13/91, effective 7/1/92.] Repealed by 95-11-107, filed 5/23/95, effective 6/30/95. Statutory Authority: RCW 19.27.074, 19.27.020, 19.27.031 and chapter 34.05 RCW.	51-24-45211 Drying apparatus. Section 45.211. [Statutory Authority: RCW 19.27.074, 19.27.031 and chapter 19.27 RCW. 92-01-065, § 51-24-45211, filed 12/13/91, effective 7/1/92.] Repealed by 95-11-107, filed 5/23/95, effective 6/30/95. Statutory Authority: RCW 19.27.074, 19.27.020, 19.27.031 and chapter 34.05 RCW.
51-24-04123	Table No. 4.108-C. Permit amounts for hazardous materials. [Statutory Authority: RCW 19.27.074, 19.27.031 and chapter 19.27 RCW. 92-01-065, § 51-24-04123, filed 12/13/91, effective 7/1/92.] Repealed by 95-11-107, filed 5/23/95, effective 6/30/95. Statutory Authority: RCW 19.27.074, 19.27.020, 19.27.031 and chapter 34.05 RCW.	51-24-78000 Article 78. [Statutory Authority: Chapter 19.27 RCW. 93-01-162, § 51-24-78000, filed 12/23/92, effective 7/1/93.] Repealed by 95-11-107, filed 5/23/95, effective 6/30/95. Statutory Authority: RCW 19.27.074, 19.27.020, 19.27.031 and chapter 34.05 RCW.
51-24-09000	Article 9. Definitions and abbreviations. [Statutory Authority: RCW 19.27.074, 19.27.031 and chapter 19.27 RCW. 92-01-065, § 51-24-09000, filed 12/13/91, effective 7/1/92.] Repealed by 95-11-107, filed 5/23/95, effective 6/30/95. Statutory Authority: RCW 19.27.074, 19.27.020, 19.27.031 and chapter 34.05 RCW.	51-24-78201 General. [Statutory Authority: Chapter 19.27 RCW. 93-01-162, § 51-24-78201, filed 12/23/92, effective 7/1/93.] Repealed by 95-11-107, filed 5/23/95, effective 6/30/95. Statutory Authority: RCW 19.27.074, 19.27.020, 19.27.031 and chapter 34.05 RCW.
51-24-09105	Section 9.105. [Statutory Authority: RCW 19.27.074, 19.27.031 and chapter 19.27 RCW. 92-01-065, § 51-24-09105, filed 12/13/91, effective 7/1/92.] Repealed by 95-11-107, filed 5/23/95, effective 6/30/95. Statutory Authority: RCW 19.27.074, 19.27.020, 19.27.031 and chapter 34.05 RCW.	51-24-79000 Article 79. Flammable and combustible liquids. [Statutory Authority: RCW 19.27.074, 19.27.031 and chapter 19.27 RCW. 92-01-065, § 51-24-79000, filed 12/13/91, effective 7/1/92.] Repealed by 95-11-107, filed 5/23/95, effective 6/30/95. Statutory Authority: RCW 19.27.074, 19.27.020, 19.27.031 and chapter 34.05 RCW.
51-24-09107	Section 9.107. [Statutory Authority: RCW 19.27.074, 19.27.031 and chapter 19.27 RCW. 92-01-065, § 51-24-09107, filed 12/13/91, effective 7/1/92.] Repealed by 95-11-107, filed 5/23/95, effective 6/30/95. Statutory Authority: RCW 19.27.074, 19.27.020, 19.27.031 and chapter 34.05 RCW.	51-24-79601 General. Section 79.601. [Statutory Authority: RCW 19.27.074, 19.27.031 and chapter 19.27 RCW. 92-01-065, § 51-24-79601, filed 12/13/91, effective 7/1/92.] Repealed by 95-11-107, filed 5/23/95, effective 6/30/95. Statutory Authority: RCW 19.27.074, 19.27.020, 19.27.031 and chapter 34.05 RCW.
51-24-09110	Section 9.110. [Statutory Authority: RCW 19.27.074, 19.27.031 and chapter 19.27 RCW. 92-01-065, § 51-24-09110, filed 12/13/91, effective 7/1/92.] Repealed by 95-11-107, filed 5/23/95, effective 6/30/95. Statutory Authority: RCW 19.27.074, 19.27.020, 19.27.031 and chapter 34.05 RCW.	51-24-79603 Corrosion protection. Section 79.603. [Statutory Authority: RCW 19.27.074, 19.27.031 and chapter 19.27 RCW. 92-01-065, § 51-24-79603, filed 12/13/91, effective 7/1/92.] Repealed by 95-11-107, filed 5/23/95, effective 6/30/95. Statutory Authority: RCW 19.27.074, 19.27.020, 19.27.031 and chapter 34.05 RCW.
51-24-09117	Section 9.117. [Statutory Authority: RCW 19.27.074, 19.27.031 and chapter 19.27 RCW. 92-01-065, § 51-24-09117, filed 12/13/91, effective 7/1/92.] Repealed by 95-11-107, filed 5/23/95, effective 6/30/95. Statutory Authority: RCW 19.27.074, 19.27.020, 19.27.031 and chapter 34.05 RCW.	51-24-79809 Unloading operations. Sec. 79.809. [Statutory Authority: RCW 19.27.074, 93-01-163, § 51-24-79809, filed 12/23/92, effective 7/1/93.] Repealed by 95-11-107, filed 5/23/95, effective 6/30/95. Statutory Authority: RCW 19.27.074, 19.27.020, 19.27.031 and chapter 34.05 RCW.
51-24-10000	Article 10. Fire protection. [Statutory Authority: RCW 19.27.074, 19.27.031 and chapter 19.27 RCW. 92-01-065, § 51-24-10000, filed 12/13/91, effective 7/1/92.] Repealed by 95-11-107, filed 5/23/95, effective 6/30/95. Statutory Authority: RCW 19.27.074, 19.27.020, 19.27.031 and chapter 34.05 RCW.	51-24-79901 General. Section 79.901. [Statutory Authority: RCW 19.27.074, 93-01-163, § 51-24-79901, filed 12/23/92, effective 7/1/93.] Repealed by 95-11-107, filed 5/23/95, effective 6/30/95. Statutory Authority: RCW 19.27.074, 19.27.020, 19.27.031 and chapter 34.05 RCW.
51-24-10201	Section 10.201. General. [Statutory Authority: RCW 19.27.074, 19.27.031 and chapter 19.27 RCW. 92-01-065, § 51-24-10201, filed 12/13/91, effective 7/1/92.] Repealed by 95-11-107, filed 5/23/95, effective 6/30/95. Statutory Authority: RCW 19.27.074, 19.27.020, 19.27.031 and chapter 34.05 RCW.	51-24-80000 Article 80. Hazardous materials. [Statutory Authority: RCW 19.27.074, 19.27.031 and chapter 19.27 RCW. 92-01-065, § 51-24-80000, filed 12/13/91, effective 7/1/92.] Repealed by 95-11-107, filed 5/23/95, effective 6/30/95. Statutory Authority: RCW 19.27.074, 19.27.020, 19.27.031 and chapter 34.05 RCW.
51-24-10507	Required installations of automatic fire-extinguishing systems. Section 10.507. [Statutory Authority: RCW 19.27.074, 19.27.031 and chapter 19.27 RCW. 92-01-065, § 51-24-10507, filed 12/13/91, effective 7/1/92.] Repealed by 95-11-107, filed 5/23/95, effective 6/30/95. Statutory Authority: RCW 19.27.074, 19.27.020, 19.27.031 and chapter 34.05 RCW.	51-24-80101 Scope. Section 80.101. [Statutory Authority: RCW 19.27.074, 19.27.031 and chapter 19.27 RCW. 92-01-065, § 51-24-80101, filed 12/13/91, effective 7/1/92.] Repealed by 95-11-107, filed 5/23/95, effective 6/30/95. Statutory Authority: RCW 19.27.074, 19.27.020, 19.27.031 and chapter 34.05 RCW.
51-24-25000	Article 25. Places of assembly. [Statutory Authority: RCW 19.27.074, 19.27.031 and chapter 19.27 RCW. 92-01-065, § 51-24-25000, filed 12/13/91, effective	51-24-80103 Permits. Section 80.103. [Statutory Authority: RCW 19.27.074, 19.27.031 and chapter 19.27 RCW. 92-01-065, § 51-24-80103, filed 12/13/91, effective 7/1/92.] Repealed by 95-11-107, filed 5/23/95, effective 6/30/95. Statutory Authority: RCW 19.27.074, 19.27.020, 19.27.031 and chapter 34.05 RCW.
		51-24-80108 Construction requirements. Section 80.108. [Statutory Authority: RCW 19.27.074, 19.27.031 and chapter

19.27 RCW. 92-01-065, § 51-24-80108, filed 12/13/91, effective 7/1/92.] Repealed by 95-11-107, filed 5/23/95, effective 6/30/95. Statutory Authority: RCW 19.27.074, 19.27.020, 19.27.031 and chapter 34.05 RCW.

51-24-80109 Personnel training and written procedures. Section 80.109. [Statutory Authority: RCW 19.27.074, 19.27.031 and chapter 19.27 RCW. 92-01-065, § 51-24-80109, filed 12/13/91, effective 7/1/92.] Repealed by 95-11-107, filed 5/23/95, effective 6/30/95. Statutory Authority: RCW 19.27.074, 19.27.020, 19.27.031 and chapter 34.05 RCW.

51-24-80110 Section 80.110. [Statutory Authority: RCW 19.27.074, 19.27.031 and chapter 19.27 RCW. 92-01-065, § 51-24-80110, filed 12/13/91, effective 7/1/92.] Repealed by 95-11-107, filed 5/23/95, effective 6/30/95. Statutory Authority: RCW 19.27.074, 19.27.020, 19.27.031 and chapter 34.05 RCW.

51-24-80111 Section 80.111. [Statutory Authority: RCW 19.27.074, 19.27.031 and chapter 19.27 RCW. 92-01-065, § 51-24-80111, filed 12/13/91, effective 7/1/92.] Repealed by 95-11-107, filed 5/23/95, effective 6/30/95. Statutory Authority: RCW 19.27.074, 19.27.020, 19.27.031 and chapter 34.05 RCW.

51-24-80113 Section 80.113. [Statutory Authority: RCW 19.27.074, 19.27.031 and chapter 19.27 RCW. 92-01-065, § 51-24-80113, filed 12/13/91, effective 7/1/92.] Repealed by 95-11-107, filed 5/23/95, effective 6/30/95. Statutory Authority: RCW 19.27.074, 19.27.020, 19.27.031 and chapter 34.05 RCW.

51-24-80114 Section 80.114. Section 80.114. [Statutory Authority: RCW 19.27.074, 19.27.031 and chapter 19.27 RCW. 92-01-065, § 51-24-80114, filed 12/13/91, effective 7/1/92.] Repealed by 95-11-107, filed 5/23/95, effective 6/30/95. Statutory Authority: RCW 19.27.074, 19.27.020, 19.27.031 and chapter 34.05 RCW.

51-24-80120 Table No. 80.112-A. [Statutory Authority: RCW 19.27.074, 19.27.031 and chapter 19.27 RCW. 92-01-065, § 51-24-80120, filed 12/13/91, effective 7/1/92.] Repealed by 95-11-107, filed 5/23/95, effective 6/30/95. Statutory Authority: RCW 19.27.074, 19.27.020, 19.27.031 and chapter 34.05 RCW.

51-24-80202 Hazard categories. Section 80.202. [Statutory Authority: RCW 19.27.074, 19.27.031 and chapter 19.27 RCW. 92-01-065, § 51-24-80202, filed 12/13/91, effective 7/1/92.] Repealed by 95-11-107, filed 5/23/95, effective 6/30/95. Statutory Authority: RCW 19.27.074, 19.27.020, 19.27.031 and chapter 34.05 RCW.

51-24-80301 General. Section 80.301. [Statutory Authority: RCW 19.27.074, 19.27.031 and chapter 19.27 RCW. 92-01-065, § 51-24-80301, filed 12/13/91, effective 7/1/92.] Repealed by 95-11-107, filed 5/23/95, effective 6/30/95. Statutory Authority: RCW 19.27.074, 19.27.020, 19.27.031 and chapter 34.05 RCW.

51-24-80303 Toxic and highly toxic compressed gases. Section 80.303. [Statutory Authority: RCW 19.27.074, 19.27.031 and chapter 19.27 RCW. 92-01-065, § 51-24-80303, filed 12/13/91, effective 7/1/92.] Repealed by 95-11-107, filed 5/23/95, effective 6/30/95. Statutory Authority: RCW 19.27.074, 19.27.020, 19.27.031 and chapter 34.05 RCW.

51-24-80305 Flammable solids and combustible dusts. Section 80.305. [Statutory Authority: RCW 19.27.074, 19.27.031 and chapter 19.27 RCW. 92-01-065, § 51-24-80305, filed 12/13/91, effective 7/1/92.] Repealed by 95-11-107, filed 5/23/95, effective 6/30/95. Statutory Authority: RCW 19.27.074, 19.27.020, 19.27.031 and chapter 34.05 RCW.

51-24-80315 Delete section 80.315 Carcinogens, irritants, sensitizers and other health hazard solids, liquids and gases entirely. [Statutory Authority: RCW 19.27.074, 19.27.031 and chapter 19.27 RCW. 92-01-065, § 51-24-80315, filed 12/13/91, effective 7/1/92.] Repealed by 95-11-107, filed 5/23/95, effective 6/30/95. Statutory Authority: RCW 19.27.074, 19.27.020, 19.27.031 and chapter 34.05 RCW.

51-24-80401 Section 80.401. [Statutory Authority: RCW 19.27.074, 19.27.031 and chapter 19.27 RCW. 92-01-065, § 51-24-80401, filed 12/13/91, effective 7/1/92.] Repealed by 95-11-107, filed 5/23/95, effective 6/30/95. Statutory Authority: RCW 19.27.074, 19.27.020, 19.27.031 and chapter 34.05 RCW.

51-24-80402 Dispensing and use. Section 80.402. [Statutory Authority: RCW 19.27.074, 19.27.031 and chapter 19.27 RCW. 92-01-065, § 51-24-80402, filed 12/13/91, effective 7/1/92.] Repealed by 95-11-107, filed 5/23/95, effective 6/30/95. Statutory Authority: RCW 19.27.074, 19.27.020, 19.27.031 and chapter 34.05 RCW.

51-24-99500 Division V. Standards. [Statutory Authority: RCW 19.27.074, 19.27.031 and chapter 19.27 RCW. 92-01-065, § 51-24-99500, filed 12/13/91, effective 7/1/92.] Repealed by 95-11-107, filed 5/23/95, effective 6/30/95. Statutory Authority: RCW 19.27.074, 19.27.020, 19.27.031 and chapter 34.05 RCW.

51-24-99510 Appendix V-A. Nationally recognized standards of good practice. [Statutory Authority: RCW 19.27.074, 19.27.031 and chapter 19.27 RCW. 92-01-065, § 51-24-99510, filed 12/13/91, effective 7/1/92.] Repealed by 95-11-107, filed 5/23/95, effective 6/30/95. Statutory Authority: RCW 19.27.074, 19.27.020, 19.27.031 and chapter 34.05 RCW.

**Chapter 51-25
STATE BUILDING CODE ADOPTION OF THE 1991 EDITION OF
THE UNIFORM FIRE CODE STANDARDS
(Replaced by chapter 51-35 WAC)**

51-25-001 Authority. [Statutory Authority: RCW 19.27.074, 19.27.031 and chapter 19.27 RCW. 92-01-065, § 51-25-001, filed 12/13/91, effective 7/1/92.] Repealed by 95-11-107, filed 5/23/95, effective 6/30/95. Statutory Authority: RCW 19.27.074, 19.27.020, 19.27.031 and chapter 34.05 RCW.

51-25-002 Purpose. [Statutory Authority: RCW 19.27.074, 19.27.031 and chapter 19.27 RCW. 92-01-065, § 51-25-002, filed 12/13/91, effective 7/1/92.] Repealed by 95-11-107, filed 5/23/95, effective 6/30/95. Statutory Authority: RCW 19.27.074, 19.27.020, 19.27.031 and chapter 34.05 RCW.

51-25-003 Uniform Fire Code standards. [Statutory Authority: RCW 19.27.074, 19.27.031 and chapter 19.27 RCW. 92-01-065, § 51-25-003, filed 12/13/91, effective 7/1/92.] Repealed by 95-11-107, filed 5/23/95, effective 6/30/95. Statutory Authority: RCW 19.27.074, 19.27.020, 19.27.031 and chapter 34.05 RCW.

51-25-007 Exceptions. [Statutory Authority: RCW 19.27.074, 19.27.031 and chapter 19.27 RCW. 92-01-065, § 51-25-007, filed 12/13/91, effective 7/1/92.] Repealed by 95-11-107, filed 5/23/95, effective 6/30/95. Statutory Authority: RCW 19.27.074, 19.27.020, 19.27.031 and chapter 34.05 RCW.

51-25-008 Implementation. [Statutory Authority: RCW 19.27.074, 19.27.031 and chapter 19.27 RCW. 92-01-065, § 51-25-008, filed 12/13/91, effective 7/1/92.] Repealed by 95-11-107, filed 5/23/95, effective 6/30/95. Statutory Authority: RCW 19.27.074, 19.27.020, 19.27.031 and chapter 34.05 RCW.

**Chapter 51-26
STATE BUILDING CODE ADOPTION AND AMENDMENT OF
THE 1991 EDITION OF THE UNIFORM PLUMBING CODE
(Replaced by chapter 51-46 WAC)**

51-26-001 Authority. [Statutory Authority: RCW 19.27.074, 19.27.031 and chapter 19.27 RCW. 92-01-066, § 51-26-001, filed 12/13/91, effective 7/1/92.] Repealed by 98-02-055, filed 1/6/98, effective 7/1/98. Statutory Authority: RCW 19.27.031 and 19.27.074.

51-26-002 Purpose. [Statutory Authority: RCW 19.27.074, 19.27.031 and chapter 19.27 RCW. 92-01-066, § 51-26-002, filed 12/13/91, effective 7/1/92.] Repealed by 98-02-055, filed 1/6/98, effective 7/1/98. Statutory Authority: RCW 19.27.031 and 19.27.074.

51-26-003 Uniform Plumbing Code. [Statutory Authority: RCW 19.27.074, 19.27.031 and chapter 19.27 RCW. 92-01-066, § 51-26-003, filed 12/13/91, effective 7/1/92.] Repealed by 98-02-055, filed 1/6/98, effective 7/1/98. Statutory Authority: RCW 19.27.031 and 19.27.074.

51-26-004 Exceptions. [Statutory Authority: RCW 19.27.074, 19.27.031 and chapter 19.27 RCW. 92-01-066, § 51-26-004, filed 12/13/91, effective 7/1/92.] Repealed by 98-02-055, filed 1/6/98, effective 7/1/98. Statutory Authority: RCW 19.27.031 and 19.27.074.

51-26-008 Implementation. [Statutory Authority: RCW 19.27.074, 19.27.031 and chapter 19.27 RCW. 92-01-066, § 51-26-008, filed 12/13/91, effective 7/1/92.] Repealed by 98-

- 02-055, filed 1/6/98, effective 7/1/98. Statutory Authority: RCW 19.27.031 and 19.27.074.
- 51-26-0300 Chapter 3—General instructions and regulations. [Statutory Authority: RCW 19.27.074, 19.27.031 and chapter 19.27 RCW. 92-01-066, § 51-26-0300, filed 12/13/91, effective 7/1/92.] Repealed by 98-02-055, filed 1/6/98, effective 7/1/98. Statutory Authority: RCW 19.27.031 and 19.27.074.
- 51-26-0310 Prohibited fittings and practices. [Statutory Authority: RCW 19.27.074, 19.27.031 and chapter 19.27 RCW. 92-01-066, § 51-26-0310, filed 12/13/91, effective 7/1/92.] Repealed by 98-02-055, filed 1/6/98, effective 7/1/98. Statutory Authority: RCW 19.27.031 and 19.27.074.
- 51-26-0315 Protection of piping, materials, and structures. [Statutory Authority: RCW 19.27.074, 19.27.031 and chapter 19.27 RCW. 92-01-066, § 51-26-0315, filed 12/13/91, effective 7/1/92.] Repealed by 98-02-055, filed 1/6/98, effective 7/1/98. Statutory Authority: RCW 19.27.031 and 19.27.074.
- 51-26-0400 Chapter 4—Drainage systems. [Statutory Authority: RCW 19.27.074, 19.27.031 and chapter 19.27 RCW. 92-01-066, § 51-26-0400, filed 12/13/91, effective 7/1/92.] Repealed by 98-02-055, filed 1/6/98, effective 7/1/98. Statutory Authority: RCW 19.27.031 and 19.27.074.
- 51-26-0401 Materials. [Statutory Authority: RCW 19.27.074, 19.27.031 and chapter 19.27 RCW. 92-01-066, § 51-26-0401, filed 12/13/91, effective 7/1/92.] Repealed by 98-02-055, filed 1/6/98, effective 7/1/98. Statutory Authority: RCW 19.27.031 and 19.27.074.
- 51-26-0500 Chapter 5—Vents and venting. [Statutory Authority: RCW 19.27.074, 19.27.031 and chapter 19.27 RCW. 92-01-066, § 51-26-0500, filed 12/13/91, effective 7/1/92.] Repealed by 98-02-055, filed 1/6/98, effective 7/1/98. Statutory Authority: RCW 19.27.031 and 19.27.074.
- 51-26-0503 Materials. [Statutory Authority: RCW 19.27.074, 19.27.031 and chapter 19.27 RCW. 92-01-066, § 51-26-0503, filed 12/13/91, effective 7/1/92.] Repealed by 98-02-055, filed 1/6/98, effective 7/1/98. Statutory Authority: RCW 19.27.031 and 19.27.074.
- 51-26-0909 Section 909—Floor drains and shower stalls. [Statutory Authority: Chapter 19.27 RCW. 95-01-124, § 51-26-0909, filed 12/21/94, effective 6/30/95.] Repealed by 98-02-055, filed 1/6/98, effective 7/1/98. Statutory Authority: RCW 19.27.031 and 19.27.074.
- 51-26-1000 Chapter 10—Water distribution. [Statutory Authority: RCW 19.27.074, 19.27.031 and chapter 19.27 RCW. 92-01-066, § 51-26-1000, filed 12/13/91, effective 7/1/92.] Repealed by 98-02-055, filed 1/6/98, effective 7/1/98. Statutory Authority: RCW 19.27.031 and 19.27.074.
- 51-26-1004 Materials. [Statutory Authority: RCW 19.27.074, 19.27.031 and chapter 19.27 RCW. 92-01-066, § 51-26-1004, filed 12/13/91, effective 7/1/92.] Repealed by 98-02-055, filed 1/6/98, effective 7/1/98. Statutory Authority: RCW 19.27.031 and 19.27.074.
- 51-26-1007 Section 1007—Water pressure, pressure regulators, and pressure relief valves. [Statutory Authority: Chapter 19.27 RCW. 95-01-124, § 51-26-1007, filed 12/21/94, effective 6/30/95.] Repealed by 98-02-055, filed 1/6/98, effective 7/1/98. Statutory Authority: RCW 19.27.031 and 19.27.074.
- 51-26-1009 Section 1009—Size of potable water piping. [Statutory Authority: Chapter 19.27 RCW. 95-01-124, § 51-26-1009, filed 12/21/94, effective 6/30/95.] Repealed by 98-02-055, filed 1/6/98, effective 7/1/98. Statutory Authority: RCW 19.27.031 and 19.27.074.
- 51-26-1020 Section 1020—Table 10-1. [Statutory Authority: Chapter 19.27 RCW. 95-01-124, § 51-26-1020, filed 12/21/94, effective 6/30/95.] Repealed by 98-02-055, filed 1/6/98, effective 7/1/98. Statutory Authority: RCW 19.27.031 and 19.27.074.
- 51-26-1301 General. [Statutory Authority: Chapter 19.27 RCW. 95-01-124, § 51-26-1301, filed 12/21/94, effective 6/30/95.] Repealed by 98-02-055, filed 1/6/98, effective 7/1/98. Statutory Authority: RCW 19.27.031 and 19.27.074.
- 51-26-1800 Chapter 18—Water conservation performance standards. [Statutory Authority: RCW 19.27.074, 19.27.031 and chapter 19.27 RCW. 92-01-066, § 51-26-1800, filed 12/13/91, effective 7/1/92.] Repealed by 98-02-055, filed 1/6/98, effective 7/1/98. Statutory Authority: RCW 19.27.031 and 19.27.074.
- 51-26-1801 Declaration of purpose. [Statutory Authority: RCW 19.27.170. 93-01-164, § 51-26-1801, filed 12/23/92, effective 7/1/93. Statutory Authority: RCW 19.27.074, 19.27.031 and chapter 19.27 RCW. 92-01-066, § 51-26-1801, filed 12/13/91, effective 7/1/92.] Repealed by 98-02-055, filed 1/6/98, effective 7/1/98. Statutory Authority: RCW 19.27.031 and 19.27.074.
- 51-26-1802 Application. [Statutory Authority: RCW 19.27.170. 93-01-164, § 51-26-1802, filed 12/23/92, effective 7/1/93. Statutory Authority: RCW 19.27.074, 19.27.031 and chapter 19.27 RCW. 92-01-066, § 51-26-1802, filed 12/13/91, effective 7/1/92.] Repealed by 98-02-055, filed 1/6/98, effective 7/1/98. Statutory Authority: RCW 19.27.031 and 19.27.074.
- 51-26-1803 Water efficiency standards. [Statutory Authority: Chapter 19.27 RCW. 95-01-124, § 51-26-1803, filed 12/21/94, effective 6/30/95. Statutory Authority: RCW 19.27.170. 93-01-164, § 51-26-1803, filed 12/23/92, effective 7/1/93. Statutory Authority: RCW 19.27.074, 19.27.031 and chapter 19.27 RCW. 92-01-066, § 51-26-1803, filed 12/13/91, effective 7/1/92.] Repealed by 98-02-055, filed 1/6/98, effective 7/1/98. Statutory Authority: RCW 19.27.031 and 19.27.074.
- 51-26-1804 Metering valves. [Statutory Authority: RCW 19.27.170. 93-01-164, § 51-26-1804, filed 12/23/92, effective 7/1/93. Statutory Authority: RCW 19.27.074, 19.27.031 and chapter 19.27 RCW. 92-01-066, § 51-26-1804, filed 12/13/91, effective 7/1/92.] Repealed by 98-02-055, filed 1/6/98, effective 7/1/98. Statutory Authority: RCW 19.27.031 and 19.27.074.
- 51-26-1805 Implementation. [Statutory Authority: RCW 19.27.074, 19.27.031 and chapter 19.27 RCW. 92-01-066, § 51-26-1805, filed 12/13/91, effective 7/1/92.] Repealed by 93-01-164, filed 12/23/92, effective 7/1/93. Statutory Authority: RCW 19.27.170.
- 51-26-1810 Reserved. [Statutory Authority: Chapter 19.27 RCW. 95-01-124, § 51-26-1810, filed 12/21/94, effective 6/30/95. Statutory Authority: RCW 19.27.170. 93-01-164, § 51-26-1810, filed 12/23/92, effective 7/1/93.] Repealed by 98-02-055, filed 1/6/98, effective 7/1/98. Statutory Authority: RCW 19.27.031 and 19.27.074.
- 51-26-1820 Reserved. [Statutory Authority: Chapter 19.27 RCW. 95-01-124, § 51-26-1820, filed 12/21/94, effective 6/30/95. Statutory Authority: RCW 19.27.170. 93-01-164, § 51-26-1820, filed 12/23/92, effective 7/1/93.] Repealed by 98-02-055, filed 1/6/98, effective 7/1/98. Statutory Authority: RCW 19.27.031 and 19.27.074.
- 51-26-1830 Accepted plumbing fixtures and fixture fittings. [Statutory Authority: Chapter 19.27 RCW. 95-01-124, § 51-26-1830, filed 12/21/94, effective 6/30/95. Statutory Authority: RCW 19.27.170. 93-01-164, § 51-26-1830, filed 12/23/92, effective 7/1/93.] Repealed by 98-02-055, filed 1/6/98, effective 7/1/98. Statutory Authority: RCW 19.27.031 and 19.27.074.
- 51-26-1840 Implementation. [Statutory Authority: RCW 19.27.170. 93-01-164, § 51-26-1840, filed 12/23/92, effective 7/1/93.] Repealed by 98-02-055, filed 1/6/98, effective 7/1/98. Statutory Authority: RCW 19.27.031 and 19.27.074.
- 51-26-1845 Amendments. [Statutory Authority: RCW 19.27.170. 93-01-164, § 51-26-1845, filed 12/23/92, effective 7/1/93.] Repealed by 98-02-055, filed 1/6/98, effective 7/1/98. Statutory Authority: RCW 19.27.031 and 19.27.074.
- 51-26-2200 Chapter 22—Minimum plumbing facilities. [Statutory Authority: Chapter 19.27 RCW. 95-01-124, § 51-26-2200, filed 12/21/94, effective 6/30/95. Statutory Authority: RCW 19.27.074, 19.27.031 and chapter 19.27 RCW. 92-01-066, § 51-26-2200, filed 12/13/91, effective 7/1/92.] Repealed by 98-02-055, filed 1/6/98, effective 7/1/98. Statutory Authority: RCW 19.27.031 and 19.27.074.
- 51-26-2300 Chapter 23—Rainwater systems. [Statutory Authority: RCW 19.27.074, 19.27.031 and chapter 19.27 RCW. 92-01-066, § 51-26-2300, filed 12/13/91, effective 7/1/92.] Repealed by 98-02-055, filed 1/6/98, effective 7/1/98. Statutory Authority: RCW 19.27.031 and 19.27.074.
- 51-26-2301 D1 materials. [Statutory Authority: RCW 19.27.074, 19.27.031 and chapter 19.27 RCW. 92-01-066, § 51-26-2301, filed 12/13/91, effective 7/1/92.] Repealed by 98-

02-055, filed 1/6/98, effective 7/1/98. Statutory Authority: RCW 19.27.031 and 19.27.074.

Chapter 51-27

STATE BUILDING CODE ADOPTION OF THE 1991 EDITION OF THE UNIFORM PLUMBING CODE STANDARDS (Replaced by chapter 51-47 WAC)

- 51-27-001 Authority. [Statutory Authority: RCW 19.27.074, 19.27.031 and chapter 19.27 RCW. 92-01-067, § 51-27-001, filed 12/13/91, effective 7/1/92.] Repealed by 98-02-055, filed 1/6/98, effective 7/1/98. Statutory Authority: RCW 19.27.031 and 19.27.074.
- 51-27-002 Purpose. [Statutory Authority: RCW 19.27.074, 19.27.031 and chapter 19.27 RCW. 92-01-067, § 51-27-002, filed 12/13/91, effective 7/1/92.] Repealed by 98-02-055, filed 1/6/98, effective 7/1/98. Statutory Authority: RCW 19.27.031 and 19.27.074.
- 51-27-003 Uniform Plumbing Code standards. [Statutory Authority: RCW 19.27.074, 19.27.031 and chapter 19.27 RCW. 92-01-067, § 51-27-003, filed 12/13/91, effective 7/1/92.] Repealed by 98-02-055, filed 1/6/98, effective 7/1/98. Statutory Authority: RCW 19.27.031 and 19.27.074.
- 51-27-004 Exceptions. [Statutory Authority: RCW 19.27.074, 19.27.031 and chapter 19.27 RCW. 92-01-067, § 51-27-004, filed 12/13/91, effective 7/1/92.] Repealed by 98-02-055, filed 1/6/98, effective 7/1/98. Statutory Authority: RCW 19.27.031 and 19.27.074.
- 51-27-008 Implementation. [Statutory Authority: RCW 19.27.074, 19.27.031 and chapter 19.27 RCW. 92-01-067, § 51-27-008, filed 12/13/91, effective 7/1/92.] Repealed by 98-02-055, filed 1/6/98, effective 7/1/98. Statutory Authority: RCW 19.27.031 and 19.27.074.

Chapter 51-30

STATE BUILDING CODE ADOPTION AND AMENDMENT OF THE 1994 EDITION OF THE UNIFORM BUILDING CODE (Replaced by chapter 51-40 WAC)

- 51-30-001 Authority. [Statutory Authority: Chapters 19.27 and 70.92 RCW. 95-01-129, § 51-30-001, filed 12/21/94, effective 6/30/95.] Repealed by 98-02-054, filed 1/6/98, effective 7/1/98. Statutory Authority: RCW 19.27.031 and 19.27.074.
- 51-30-002 Purpose. [Statutory Authority: Chapters 19.27 and 70.92 RCW. 95-01-129, § 51-30-002, filed 12/21/94, effective 6/30/95.] Repealed by 98-02-054, filed 1/6/98, effective 7/1/98. Statutory Authority: RCW 19.27.031 and 19.27.074.
- 51-30-003 Uniform Building Code. [Statutory Authority: Chapters 19.27 and 70.92 RCW. 95-01-129, § 51-30-003, filed 12/21/94, effective 6/30/95.] Repealed by 98-02-054, filed 1/6/98, effective 7/1/98. Statutory Authority: RCW 19.27.031 and 19.27.074.
- 51-30-004 Conflicts with Washington State Ventilation and Indoor Air Quality Code. [Statutory Authority: Chapters 19.27 and 70.92 RCW. 95-01-129, § 51-30-004, filed 12/21/94, effective 6/30/95.] Repealed by 98-02-054, filed 1/6/98, effective 7/1/98. Statutory Authority: RCW 19.27.031 and 19.27.074.
- 51-30-005 Uniform Building Code requirements for barrier-free accessibility. [Statutory Authority: Chapters 19.27 and 70.92 RCW. 95-01-129, § 51-30-005, filed 12/21/94, effective 6/30/95.] Repealed by 98-02-054, filed 1/6/98, effective 7/1/98. Statutory Authority: RCW 19.27.031 and 19.27.074.
- 51-30-007 Exceptions. [Statutory Authority: Chapters 19.27 and 70.92 RCW. 95-01-129, § 51-30-007, filed 12/21/94, effective 6/30/95.] Repealed by 98-02-054, filed 1/6/98, effective 7/1/98. Statutory Authority: RCW 19.27.031 and 19.27.074.
- 51-30-008 Implementation. [Statutory Authority: Chapters 19.27 and 70.92 RCW. 95-01-129, § 51-30-008, filed 12/21/94, effective 6/30/95.] Repealed by 98-02-054, filed 1/6/98, effective 7/1/98. Statutory Authority: RCW 19.27.031 and 19.27.074.
- 51-30-009 Recyclable materials and solid waste storage. [Statutory Authority: Chapters 19.27 and 70.92 RCW. 95-01-129, § 51-30-009, filed 12/21/94, effective 6/30/95.] Repealed by 98-02-054, filed 1/6/98, effective 7/1/98. Statutory Authority: RCW 19.27.031 and 19.27.074.
- 51-30-0100 Chapter 1—Administration. [Statutory Authority: Chapters 19.27 and 70.92 RCW. 95-01-129, § 51-30-0100, filed 12/21/94, effective 6/30/95.] Repealed by

51-30-0104

51-30-0200

51-30-0204

51-30-0207

51-30-0217

51-30-0220

51-30-0300

51-30-0302

51-30-0304

51-30-0305

51-30-0307

51-30-0310

51-30-0313

51-30-0400

51-30-0403

98-02-054, filed 1/6/98, effective 7/1/98. Statutory Authority: RCW 19.27.031 and 19.27.074.

Section 104—Organization and enforcement. [Statutory Authority: Chapters 19.27 and 70.92 RCW. 95-01-129, § 51-30-0104, filed 12/21/94, effective 6/30/95.] Repealed by 98-02-054, filed 1/6/98, effective 7/1/98. Statutory Authority: RCW 19.27.031 and 19.27.074.

Chapter 2—Definitions and abbreviations. [Statutory Authority: Chapters 19.27 and 70.92 RCW. 95-01-129, § 51-30-0200, filed 12/21/94, effective 6/30/95.] Repealed by 98-02-054, filed 1/6/98, effective 7/1/98. Statutory Authority: RCW 19.27.031 and 19.27.074.

Section 204—C. [Statutory Authority: Chapters 19.27 and 70.92 RCW. 95-01-129, § 51-30-0204, filed 12/21/94, effective 6/30/95.] Repealed by 98-02-054, filed 1/6/98, effective 7/1/98. Statutory Authority: RCW 19.27.031 and 19.27.074.

Section 207—F. [Statutory Authority: Chapters 19.27 and 70.92 RCW. 95-01-129, § 51-30-0207, filed 12/21/94, effective 6/30/95.] Repealed by 98-02-054, filed 1/6/98, effective 7/1/98. Statutory Authority: RCW 19.27.031 and 19.27.074.

Section 217—P. [Statutory Authority: Chapters 19.27 and 70.92 RCW. 95-01-129, § 51-30-0217, filed 12/21/94, effective 6/30/95.] Repealed by 98-02-054, filed 1/6/98, effective 7/1/98. Statutory Authority: RCW 19.27.031 and 19.27.074.

Section 220—S. [Statutory Authority: Chapters 19.27 and 70.92 RCW. 95-01-129, § 51-30-0220, filed 12/21/94, effective 6/30/95.] Repealed by 98-02-054, filed 1/6/98, effective 7/1/98. Statutory Authority: RCW 19.27.031 and 19.27.074.

Chapter 3—Use or occupancy. [Statutory Authority: Chapters 19.27 and 70.92 RCW. 95-01-129, § 51-30-0300, filed 12/21/94, effective 6/30/95.] Repealed by 98-02-054, filed 1/6/98, effective 7/1/98. Statutory Authority: RCW 19.27.031 and 19.27.074.

Section 302—Mixed use or occupancy. [Statutory Authority: Chapters 19.27 and 70.92 RCW. 95-01-129, § 51-30-0302, filed 12/21/94, effective 6/30/95.] Repealed by 98-02-054, filed 1/6/98, effective 7/1/98. Statutory Authority: RCW 19.27.031 and 19.27.074.

Section 304—Requirements for Group B Occupancies. [Statutory Authority: Chapters 19.27 and 70.92 RCW. 95-01-129, § 51-30-0304, filed 12/21/94, effective 6/30/95.] Repealed by 98-02-054, filed 1/6/98, effective 7/1/98. Statutory Authority: RCW 19.27.031 and 19.27.074.

Section 305—Requirements for Group E Occupancies. [Statutory Authority: Chapters 19.27 and 70.92 RCW. 95-01-129, § 51-30-0305, filed 12/21/94, effective 6/30/95.] Repealed by 98-02-054, filed 1/6/98, effective 7/1/98. Statutory Authority: RCW 19.27.031 and 19.27.074.

Section 307—Requirements for Group H Occupancies. [Statutory Authority: Chapters 19.27 and 70.92 RCW. 95-01-129, § 51-30-0307, filed 12/21/94, effective 6/30/95.] Repealed by 98-02-054, filed 1/6/98, effective 7/1/98. Statutory Authority: RCW 19.27.031 and 19.27.074.

Section 310—Requirements for Group R Occupancies. [Statutory Authority: Chapters 19.27 and 70.92 RCW. 95-01-129, § 51-30-0310, filed 12/21/94, effective 6/30/95.] Repealed by 98-02-054, filed 1/6/98, effective 7/1/98. Statutory Authority: RCW 19.27.031 and 19.27.074.

Section 313—Requirements for Group LC Occupancies. [Statutory Authority: Chapters 19.27 and 70.92 RCW. 95-01-129, § 51-30-0313, filed 12/21/94, effective 6/30/95.] Repealed by 98-02-054, filed 1/6/98, effective 7/1/98. Statutory Authority: RCW 19.27.031 and 19.27.074.

Chapter 4—Special use and occupancy. [Statutory Authority: Chapters 19.27 and 70.92 RCW. 95-01-129, § 51-30-0400, filed 12/21/94, effective 6/30/95.] Repealed by 98-02-054, filed 1/6/98, effective 7/1/98. Statutory Authority: RCW 19.27.031 and 19.27.074.

Section 403—Special provisions for Group B office buildings and Group R, Division 1 Occupancies. [Statutory Authority: Chapters 19.27 and 70.92 RCW. 95-01-129, § 51-30-0403, filed 12/21/94, effective 6/30/95.] Repealed by 98-02-054, filed 1/6/98, effective 7/1/98. Statutory Authority: RCW 19.27.031 and 19.27.074.

51-30-0405	Section 405—Stages and platforms. [Statutory Authority: Chapters 19.27 and 70.92 RCW. 95-01-129, § 51-30-0405, filed 12/21/94, effective 6/30/95.] Repealed by 98-02-054, filed 1/6/98, effective 7/1/98. Statutory Authority: RCW 19.27.031 and 19.27.074.	51-30-1009	Section 1009—Stairway, Ramp and Escalator Enclosures. [Statutory Authority: Chapters 19.27 and 70.92 RCW. 95-01-129, § 51-30-1009, filed 12/21/94, effective 6/30/95.] Repealed by 98-02-054, filed 1/6/98, effective 7/1/98. Statutory Authority: RCW 19.27.031 and 19.27.074.
51-30-0500	Chapter 5—General building limitations. [Statutory Authority: Chapters 19.27 and 70.92 RCW. 95-01-129, § 51-30-0500, filed 12/21/94, effective 6/30/95.] Repealed by 98-02-054, filed 1/6/98, effective 7/1/98. Statutory Authority: RCW 19.27.031 and 19.27.074.	51-30-1014	Section 1014—Aisles. [Statutory Authority: Chapters 19.27 and 70.92 RCW. 95-01-129, § 51-30-1014, filed 12/21/94, effective 6/30/95.] Repealed by 98-02-054, filed 1/6/98, effective 7/1/98. Statutory Authority: RCW 19.27.031 and 19.27.074.
51-30-0510	Section 510—Heating. [Statutory Authority: Chapters 19.27 and 70.92 RCW. 95-01-129, § 51-30-0510, filed 12/21/94, effective 6/30/95.] Repealed by 98-02-054, filed 1/6/98, effective 7/1/98. Statutory Authority: RCW 19.27.031 and 19.27.074.	51-30-1019	Group I Occupancies. [Statutory Authority: Chapters 19.27 and 70.92 RCW. 95-01-129, § 51-30-1019, filed 12/21/94, effective 6/30/95.] Repealed by 98-02-054, filed 1/6/98, effective 7/1/98. Statutory Authority: RCW 19.27.031 and 19.27.074.
51-30-0600	Chapter 6—Types of construction. [Statutory Authority: Chapters 19.27 and 70.92 RCW. 95-01-129, § 51-30-0600, filed 12/21/94, effective 6/30/95.] Repealed by 98-02-054, filed 1/6/98, effective 7/1/98. Statutory Authority: RCW 19.27.031 and 19.27.074.	51-30-1030	Table 10-A—Minimum egress requirements. [Statutory Authority: Chapters 19.27 and 70.92 RCW. 95-01-129, § 51-30-1030, filed 12/21/94, effective 6/30/95.] Repealed by 98-02-054, filed 1/6/98, effective 7/1/98. Statutory Authority: RCW 19.27.031 and 19.27.074.
51-30-0601	Section 601—Classification of all buildings by types of construction and general requirements. [Statutory Authority: Chapters 19.27 and 70.92 RCW. 95-01-129, § 51-30-0601, filed 12/21/94, effective 6/30/95.] Repealed by 98-02-054, filed 1/6/98, effective 7/1/98. Statutory Authority: RCW 19.27.031 and 19.27.074.	51-30-1100	Chapter 11—Accessibility. [Statutory Authority: Chapters 19.27 and 70.92 RCW. 95-01-129, § 51-30-1100, filed 12/21/94, effective 6/30/95.] Repealed by 98-02-054, filed 1/6/98, effective 7/1/98. Statutory Authority: RCW 19.27.031 and 19.27.074.
51-30-0800	Chapter 8—Interior finishes. [Statutory Authority: Chapters 19.27 and 70.92 RCW. 95-01-129, § 51-30-0800, filed 12/21/94, effective 6/30/95.] Repealed by 98-02-054, filed 1/6/98, effective 7/1/98. Statutory Authority: RCW 19.27.031 and 19.27.074.	51-30-1101	Section 1101—Scope. [Statutory Authority: Chapters 19.27 and 70.92 RCW. 95-01-129, § 51-30-1101, filed 12/21/94, effective 6/30/95.] Repealed by 98-02-054, filed 1/6/98, effective 7/1/98. Statutory Authority: RCW 19.27.031 and 19.27.074.
51-30-0804	Section 804—Maximum allowable flame spread. [Statutory Authority: Chapters 19.27 and 70.92 RCW. 95-01-129, § 51-30-0804, filed 12/21/94, effective 6/30/95.] Repealed by 98-02-054, filed 1/6/98, effective 7/1/98. Statutory Authority: RCW 19.27.031 and 19.27.074.	51-30-1102	Section 1102—Definitions. [Statutory Authority: Chapters 19.27 and 70.92 RCW. 95-01-129, § 51-30-1102, filed 12/21/94, effective 6/30/95.] Repealed by 98-02-054, filed 1/6/98, effective 7/1/98. Statutory Authority: RCW 19.27.031 and 19.27.074.
51-30-0900	Chapter 9—Fire-protection systems. [Statutory Authority: Chapters 19.27 and 70.92 RCW. 95-01-129, § 51-30-0900, filed 12/21/94, effective 6/30/95.] Repealed by 98-02-054, filed 1/6/98, effective 7/1/98. Statutory Authority: RCW 19.27.031 and 19.27.074.	51-30-1103	Section 1103—Building accessibility. [Statutory Authority: Chapters 19.27 and 70.92 RCW. 95-01-129, § 51-30-1103, filed 12/21/94, effective 6/30/95.] Repealed by 98-02-054, filed 1/6/98, effective 7/1/98. Statutory Authority: RCW 19.27.031 and 19.27.074.
51-30-0902	Section 902—Standards of quality. [Statutory Authority: Chapters 19.27 and 70.92 RCW. 95-01-129, § 51-30-0902, filed 12/21/94, effective 6/30/95.] Repealed by 98-02-054, filed 1/6/98, effective 7/1/98. Statutory Authority: RCW 19.27.031 and 19.27.074.	51-30-1104	Section 1104—Egress and areas of evacuation assistance. [Statutory Authority: Chapters 19.27 and 70.92 RCW. 95-01-129, § 51-30-1104, filed 12/21/94, effective 6/30/95.] Repealed by 98-02-054, filed 1/6/98, effective 7/1/98. Statutory Authority: RCW 19.27.031 and 19.27.074.
51-30-0904	Section 904—Fire-extinguishing systems. [Statutory Authority: Chapters 19.27 and 70.92 RCW. 95-01-129, § 51-30-0904, filed 12/21/94, effective 6/30/95.] Repealed by 98-02-054, filed 1/6/98, effective 7/1/98. Statutory Authority: RCW 19.27.031 and 19.27.074.	51-30-1105	Section 1105—Facility accessibility. [Statutory Authority: Chapters 19.27 and 70.92 RCW. 95-01-129, § 51-30-1105, filed 12/21/94, effective 6/30/95.] Repealed by 98-02-054, filed 1/6/98, effective 7/1/98. Statutory Authority: RCW 19.27.031 and 19.27.074.
51-30-1000	Chapter 10—Means of egress. [Statutory Authority: Chapters 19.27 and 70.92 RCW. 95-01-129, § 51-30-1000, filed 12/21/94, effective 6/30/95.] Repealed by 98-02-054, filed 1/6/98, effective 7/1/98. Statutory Authority: RCW 19.27.031 and 19.27.074.	51-30-1106	Section 1106—Accessible design and standards. [Statutory Authority: Chapters 19.27 and 70.92 RCW. 95-01-129, § 51-30-1106, filed 12/21/94, effective 6/30/95.] Repealed by 98-02-054, filed 1/6/98, effective 7/1/98. Statutory Authority: RCW 19.27.031 and 19.27.074.
51-30-1001	Section 1001—General. [Statutory Authority: Chapters 19.27 and 70.92 RCW. 95-01-129, § 51-30-1001, filed 12/21/94, effective 6/30/95.] Repealed by 98-02-054, filed 1/6/98, effective 7/1/98. Statutory Authority: RCW 19.27.031 and 19.27.074.	51-30-1107	Section 1107—Parking facilities. [Statutory Authority: Chapters 19.27 and 70.92 RCW. 95-01-129, § 51-30-1107, filed 12/21/94, effective 6/30/95.] Repealed by 98-02-054, filed 1/6/98, effective 7/1/98. Statutory Authority: RCW 19.27.031 and 19.27.074.
51-30-1004	Section 1004—Doors. [Statutory Authority: Chapters 19.27 and 70.92 RCW. 95-01-129, § 51-30-1004, filed 12/21/94, effective 6/30/95.] Repealed by 98-02-054, filed 1/6/98, effective 7/1/98. Statutory Authority: RCW 19.27.031 and 19.27.074.	51-30-1108	Section 1108—Passenger loading zones. [Statutory Authority: Chapters 19.27 and 70.92 RCW. 95-01-129, § 51-30-1108, filed 12/21/94, effective 6/30/95.] Repealed by 98-02-054, filed 1/6/98, effective 7/1/98. Statutory Authority: RCW 19.27.031 and 19.27.074.
51-30-1005	Section 1005—Corridors and exterior exit balconies. [Statutory Authority: Chapters 19.27 and 70.92 RCW. 95-01-129, § 51-30-1005, filed 12/21/94, effective 6/30/95.] Repealed by 98-02-054, filed 1/6/98, effective 7/1/98. Statutory Authority: RCW 19.27.031 and 19.27.074.	51-30-1109	Section 1109—Scope. [Statutory Authority: Chapters 19.27 and 70.92 RCW. 95-01-129, § 51-30-1109, filed 12/21/94, effective 6/30/95.] Repealed by 98-02-054, filed 1/6/98, effective 7/1/98. Statutory Authority: RCW 19.27.031 and 19.27.074.
51-30-1006	Section 1006—Stairways. [Statutory Authority: Chapters 19.27 and 70.92 RCW. 95-01-129, § 51-30-1006, filed 12/21/94, effective 6/30/95.] Repealed by 98-02-054, filed 1/6/98, effective 7/1/98. Statutory Authority: RCW 19.27.031 and 19.27.074.	51-30-1110	Section 1110—Definitions. [Statutory Authority: Chapters 19.27 and 70.92 RCW. 95-01-129, § 51-30-1110, filed 12/21/94, effective 6/30/95.] Repealed by 98-02-054, filed 1/6/98, effective 7/1/98. Statutory Authority: RCW 19.27.031 and 19.27.074.
51-30-1007	Section 1007—Ramps. [Statutory Authority: Chapters 19.27 and 70.92 RCW. 95-01-129, § 51-30-1007, filed 12/21/94, effective 6/30/95.] Repealed by 98-02-054, filed 1/6/98, effective 7/1/98. Statutory Authority: RCW 19.27.031 and 19.27.074.	51-30-1111	Section 1111—Additions. [Statutory Authority: Chapters 19.27 and 70.92 RCW. 95-01-129, § 51-30-1111, filed 12/21/94, effective 6/30/95.] Repealed by 98-02-054, filed 1/6/98, effective 7/1/98. Statutory Authority: RCW 19.27.031 and 19.27.074.
		51-30-1112	Section 1112—Alterations. [Statutory Authority: Chapters 19.27 and 70.92 RCW. 95-01-129, § 51-30-1112,

	filed 12/21/94, effective 6/30/95.] Repealed by 98-02-054, filed 1/6/98, effective 7/1/98. Statutory Authority: RCW 19.27.031 and 19.27.074.		
51-30-1113	Section 1113—Historic preservation. [Statutory Authority: Chapters 19.27 and 70.92 RCW. 95-01-129, § 51-30-1113, filed 12/21/94, effective 6/30/95.] Repealed by 98-02-054, filed 1/6/98, effective 7/1/98. Statutory Authority: RCW 19.27.031 and 19.27.074.	51-30-2200	Chapter 22—Steel. [Statutory Authority: Chapters 19.27 and 70.92 RCW. 95-01-129, § 51-30-2200, filed 12/21/94, effective 6/30/95.] Repealed by 98-02-054, filed 1/6/98, effective 7/1/98. Statutory Authority: RCW 19.27.031 and 19.27.074.
51-30-1114	Section 1114—Appeal. [Statutory Authority: Chapters 19.27 and 70.92 RCW. 95-01-129, § 51-30-1114, filed 12/21/94, effective 6/30/95.] Repealed by 98-02-054, filed 1/6/98, effective 7/1/98. Statutory Authority: RCW 19.27.031 and 19.27.074.	51-30-2211	Section 2211—Steel structures resisting forces induced by earthquake motions in seismic zones 3 and 4. [Statutory Authority: Chapters 19.27 and 70.92 RCW. 95-01-129, § 51-30-2211, filed 12/21/94, effective 6/30/95.] Repealed by 98-02-054, filed 1/6/98, effective 7/1/98. Statutory Authority: RCW 19.27.031 and 19.27.074.
51-30-1120	Table No. 11-A. [Statutory Authority: Chapters 19.27 and 70.92 RCW. 95-01-129, § 51-30-1120, filed 12/21/94, effective 6/30/95.] Repealed by 98-02-054, filed 1/6/98, effective 7/1/98. Statutory Authority: RCW 19.27.031 and 19.27.074.	51-30-2400	Chapter 24—Glass and glazing. [Statutory Authority: Chapters 19.27 and 70.92 RCW. 95-01-129, § 51-30-2400, filed 12/21/94, effective 6/30/95.] Repealed by 98-02-054, filed 1/6/98, effective 7/1/98. Statutory Authority: RCW 19.27.031 and 19.27.074.
51-30-1121	Table No. 11-B. [Statutory Authority: Chapters 19.27 and 70.92 RCW. 95-01-129, § 51-30-1121, filed 12/21/94, effective 6/30/95.] Repealed by 98-02-054, filed 1/6/98, effective 7/1/98. Statutory Authority: RCW 19.27.031 and 19.27.074.	51-30-2406	Section 2406—Safety glazing. [Statutory Authority: Chapters 19.27 and 70.92 RCW. 95-01-129, § 51-30-2406, filed 12/21/94, effective 6/30/95.] Repealed by 98-02-054, filed 1/6/98, effective 7/1/98. Statutory Authority: RCW 19.27.031 and 19.27.074.
51-30-1122	Table No. 11-C. [Statutory Authority: Chapters 19.27 and 70.92 RCW. 95-01-129, § 51-30-1122, filed 12/21/94, effective 6/30/95.] Repealed by 98-02-054, filed 1/6/98, effective 7/1/98. Statutory Authority: RCW 19.27.031 and 19.27.074.	51-30-2900	Chapter 29—Plumbing systems. [Statutory Authority: Chapters 19.27 and 70.92 RCW. 95-01-129, § 51-30-2900, filed 12/21/94, effective 6/30/95.] Repealed by 98-02-054, filed 1/6/98, effective 7/1/98. Statutory Authority: RCW 19.27.031 and 19.27.074.
51-30-1123	Table No. 11-D. [Statutory Authority: Chapters 19.27 and 70.92 RCW. 95-01-129, § 51-30-1123, filed 12/21/94, effective 6/30/95.] Repealed by 98-02-054, filed 1/6/98, effective 7/1/98. Statutory Authority: RCW 19.27.031 and 19.27.074.	51-30-2902	Section 2902—Number of fixtures. [Statutory Authority: Chapters 19.27 and 70.92 RCW. 95-01-129, § 51-30-2902, filed 12/21/94, effective 6/30/95.] Repealed by 98-02-054, filed 1/6/98, effective 7/1/98. Statutory Authority: RCW 19.27.031 and 19.27.074.
51-30-1124	Table No. 11-E. [Statutory Authority: Chapters 19.27 and 70.92 RCW. 95-01-129, § 51-30-1124, filed 12/21/94, effective 6/30/95.] Repealed by 98-02-054, filed 1/6/98, effective 7/1/98. Statutory Authority: RCW 19.27.031 and 19.27.074.	51-30-2903	Section 2903—Accessibility. [Statutory Authority: Chapters 19.27 and 70.92 RCW. 95-01-129, § 51-30-2903, filed 12/21/94, effective 6/30/95.] Repealed by 98-02-054, filed 1/6/98, effective 7/1/98. Statutory Authority: RCW 19.27.031 and 19.27.074.
51-30-1125	Table No. 11-F. [Statutory Authority: Chapters 19.27 and 70.92 RCW. 95-01-129, § 51-30-1125, filed 12/21/94, effective 6/30/95.] Repealed by 98-02-054, filed 1/6/98, effective 7/1/98. Statutory Authority: RCW 19.27.031 and 19.27.074.	51-30-2904	Section 2904—Plumbing fixtures. [Statutory Authority: Chapters 19.27 and 70.92 RCW. 95-01-129, § 51-30-2904, filed 12/21/94, effective 6/30/95.] Repealed by 98-02-054, filed 1/6/98, effective 7/1/98. Statutory Authority: RCW 19.27.031 and 19.27.074.
51-30-1200	Chapter 12—Interior environment. [Statutory Authority: Chapters 19.27 and 70.92 RCW. 95-01-129, § 51-30-1200, filed 12/21/94, effective 6/30/95.] Repealed by 98-02-054, filed 1/6/98, effective 7/1/98. Statutory Authority: RCW 19.27.031 and 19.27.074.	51-30-2910	Table 29-A—Minimum plumbing fixtures. [Statutory Authority: Chapters 19.27 and 70.92 RCW. 95-01-129, § 51-30-2910, filed 12/21/94, effective 6/30/95.] Repealed by 98-02-054, filed 1/6/98, effective 7/1/98. Statutory Authority: RCW 19.27.031 and 19.27.074.
51-30-1203	Section 1203—Light and ventilation in Group R Occupancies. [Statutory Authority: Chapters 19.27 and 70.92 RCW. 95-01-129, § 51-30-1203, filed 12/21/94, effective 6/30/95.] Repealed by 98-02-054, filed 1/6/98, effective 7/1/98. Statutory Authority: RCW 19.27.031 and 19.27.074.	51-30-3102	Section 3102.5.4. [Statutory Authority: RCW 19.27.074(1) and 70.94.457 (1)(b), (c). 96-01-120, § 51-30-3102, filed 12/20/95, effective 1/1/97.] Repealed by 98-02-054, filed 1/6/98, effective 7/1/98. Statutory Authority: RCW 19.27.031 and 19.27.074.
51-30-1600	Chapter 16—Structural forces. [Statutory Authority: Chapters 19.27 and 70.92 RCW. 95-01-129, § 51-30-1600, filed 12/21/94, effective 6/30/95.] Repealed by 98-02-054, filed 1/6/98, effective 7/1/98. Statutory Authority: RCW 19.27.031 and 19.27.074.	51-30-31200	Section 31.200. [Statutory Authority: RCW 19.27.074(1) and 70.94.457 (1)(b), (c). 96-01-120, § 51-30-31200, filed 12/20/95, effective 1/1/97.] Repealed by 98-02-054, filed 1/6/98, effective 7/1/98. Statutory Authority: RCW 19.27.031 and 19.27.074.
51-30-1614	Section 1614—Definitions. [Statutory Authority: Chapters 19.27 and 70.92 RCW. 95-01-129, § 51-30-1614, filed 12/21/94, effective 6/30/95.] Repealed by 98-02-054, filed 1/6/98, effective 7/1/98. Statutory Authority: RCW 19.27.031 and 19.27.074.	51-30-31201	Section 31.201—Definitions. [Statutory Authority: RCW 19.27.074(1) and 70.94.457 (1)(b), (c). 96-01-120, § 51-30-31201, filed 12/20/95, effective 1/1/97.] Repealed by 98-02-054, filed 1/6/98, effective 7/1/98. Statutory Authority: RCW 19.27.031 and 19.27.074.
51-30-1700	Chapter 17—Structural test and inspections. [Statutory Authority: Chapters 19.27 and 70.92 RCW. 95-01-129, § 51-30-1700, filed 12/21/94, effective 6/30/95.] Repealed by 98-02-054, filed 1/6/98, effective 7/1/98. Statutory Authority: RCW 19.27.031 and 19.27.074.	51-30-31202	Section 31.202—Testing. [Statutory Authority: RCW 19.27.074(1) and 70.94.457 (1)(b), (c). 96-01-120, § 51-30-31202, filed 12/20/95, effective 1/1/97.] Repealed by 98-02-054, filed 1/6/98, effective 7/1/98. Statutory Authority: RCW 19.27.031 and 19.27.074.
51-30-1702	Section 1702—Structural observation. [Statutory Authority: Chapters 19.27 and 70.92 RCW. 95-01-129, § 51-30-1702, filed 12/21/94, effective 6/30/95.] Repealed by 98-02-054, filed 1/6/98, effective 7/1/98. Statutory Authority: RCW 19.27.031 and 19.27.074.	51-30-31203	Section 31.203—Test protocol. [Statutory Authority: RCW 19.27.074(1) and 70.94.457 (1)(b), (c). 96-01-120, § 51-30-31203, filed 12/20/95, effective 1/1/97.] Repealed by 98-02-054, filed 1/6/98, effective 7/1/98. Statutory Authority: RCW 19.27.031 and 19.27.074.
51-30-1900	Chapter 19—Concrete. [Statutory Authority: Chapters 19.27 and 70.92 RCW. 95-01-129, § 51-30-1900, filed 12/21/94, effective 6/30/95.] Repealed by 98-02-054, filed 1/6/98, effective 7/1/98. Statutory Authority: RCW 19.27.031 and 19.27.074.	51-30-31204	Section 31.204—Approval procedure for fireplaces. [Statutory Authority: RCW 19.27.074(1) and 70.94.457 (1)(b), (c). 96-01-120, § 51-30-31204, filed 12/20/95, effective 1/1/97.] Repealed by 98-02-054, filed 1/6/98, effective 7/1/98. Statutory Authority: RCW 19.27.031 and 19.27.074.
51-30-1909	Section 1909—Strength and serviceability requirements. [Statutory Authority: Chapters 19.27 and 70.92 RCW. 95-01-129, § 51-30-1909, filed 12/21/94, effective 6/30/95.] Repealed by 98-02-054, filed 1/6/98,	51-30-31205	Section 31.205—Approval of non-tested fireplaces. [Statutory Authority: RCW 19.27.074(1) and 70.94.457 (1)(b), (c). 96-01-120, § 51-30-31205, filed 12/20/95, effective 1/1/97.] Repealed by 98-02-054, filed 1/6/98,

	effective 7/1/98. Statutory Authority: RCW 19.27.031 and 19.27.074.		
51-30-31206	Section 31.206—Approval through alternative test protocol. [Statutory Authority: RCW 19.27.074(1) and 70.94.457 (1)(b), (c). 96-01-120, § 51-30-31206, filed 12/20/95, effective 1/1/97.] Repealed by 98-02-054, filed 1/6/98, effective 7/1/98. Statutory Authority: RCW 19.27.031 and 19.27.074.	51-32-003	Repealed by 98-02-056, filed 1/6/98, effective 7/1/98. Statutory Authority: RCW 19.27.031 and 19.27.074. Uniform Mechanical Code. [Statutory Authority: Chapter 19.27 RCW. 95-01-123, § 51-32-003, filed 12/21/94, effective 6/30/95.] Repealed by 98-02-056, filed 1/6/98, effective 7/1/98. Statutory Authority: RCW 19.27.031 and 19.27.074.
51-30-31207	Section 31.207—Approval termination. [Statutory Authority: RCW 19.27.074(1) and 70.94.457 (1)(b), (c). 96-01-120, § 51-30-31207, filed 12/20/95, effective 1/1/97.] Repealed by 98-02-054, filed 1/6/98, effective 7/1/98. Statutory Authority: RCW 19.27.031 and 19.27.074.	51-32-004	Conflict between Uniform Mechanical Code and State Energy Code chapter 51-11 WAC. [Statutory Authority: Chapter 19.27 RCW. 95-01-123, § 51-32-004, filed 12/21/94, effective 6/30/95.] Repealed by 98-02-056, filed 1/6/98, effective 7/1/98. Statutory Authority: RCW 19.27.031 and 19.27.074.
51-30-31208	Section 31.208—Quality control. [Statutory Authority: RCW 19.27.074(1) and 70.94.457 (1)(b), (c). 96-01-120, § 51-30-31208, filed 12/20/95, effective 1/1/97.] Repealed by 98-02-054, filed 1/6/98, effective 7/1/98. Statutory Authority: RCW 19.27.031 and 19.27.074.	51-32-005	Conflict between Uniform Mechanical Code and State Ventilation and Indoor Air Quality Code chapter 51-13 WAC. [Statutory Authority: Chapter 19.27 RCW. 95-01-123, § 51-32-005, filed 12/21/94, effective 6/30/95.] Repealed by 98-02-056, filed 1/6/98, effective 7/1/98. Statutory Authority: RCW 19.27.031 and 19.27.074.
51-30-31209	Section 31.209—Permanent label, temporary label and owner's manual. [Statutory Authority: RCW 19.27.074(1) and 70.94.457 (1)(b), (c). 96-01-120, § 51-30-31209, filed 12/20/95, effective 1/1/97.] Repealed by 98-02-054, filed 1/6/98, effective 7/1/98. Statutory Authority: RCW 19.27.031 and 19.27.074.	51-32-007	Exceptions. [Statutory Authority: Chapter 19.27 RCW. 95-01-123, § 51-32-007, filed 12/21/94, effective 6/30/95.] Repealed by 98-02-056, filed 1/6/98, effective 7/1/98. Statutory Authority: RCW 19.27.031 and 19.27.074.
51-30-31210	Section 31.210—List of approved fireplaces. [Statutory Authority: RCW 19.27.074(1) and 70.94.457 (1)(b), (c). 96-01-120, § 51-30-31210, filed 12/20/95, effective 1/1/97.] Repealed by 98-02-054, filed 1/6/98, effective 7/1/98. Statutory Authority: RCW 19.27.031 and 19.27.074.	51-32-008	Implementation. [Statutory Authority: Chapter 19.27 RCW. 95-01-123, § 51-32-008, filed 12/21/94, effective 6/30/95.] Repealed by 98-02-056, filed 1/6/98, effective 7/1/98. Statutory Authority: RCW 19.27.031 and 19.27.074.
51-30-3400	Chapter 34—Existing structures. [Statutory Authority: Chapters 19.27 and 70.92 RCW. 95-01-129, § 51-30-3400, filed 12/21/94, effective 6/30/95.] Repealed by 98-02-054, filed 1/6/98, effective 7/1/98. Statutory Authority: RCW 19.27.031 and 19.27.074.	51-32-0200	Chapter 2—Definitions. [Statutory Authority: Chapter 19.27 RCW. 95-01-123, § 51-32-0200, filed 12/21/94, effective 6/30/95.] Repealed by 98-02-056, filed 1/6/98, effective 7/1/98. Statutory Authority: RCW 19.27.031 and 19.27.074.
51-30-3404	Section 3404—Moved buildings. [Statutory Authority: Chapters 19.27 and 70.92 RCW. 95-01-129, § 51-30-3404, filed 12/21/94, effective 6/30/95.] Repealed by 98-02-054, filed 1/6/98, effective 7/1/98. Statutory Authority: RCW 19.27.031 and 19.27.074.	51-32-0223	Section 223—U. [Statutory Authority: Chapter 19.27 RCW. 95-01-123, § 51-32-0223, filed 12/21/94, effective 6/30/95.] Repealed by 98-02-056, filed 1/6/98, effective 7/1/98. Statutory Authority: RCW 19.27.031 and 19.27.074.
51-30-93115	Section 93115. [Statutory Authority: Chapters 19.27 and 70.92 RCW. 95-01-129, § 51-30-93115, filed 12/21/94, effective 6/30/95.] Repealed by 98-02-054, filed 1/6/98, effective 7/1/98. Statutory Authority: RCW 19.27.031 and 19.27.074.	51-32-0300	Chapter 3—General requirements for heating, ventilating and cooling. [Statutory Authority: Chapter 19.27 RCW. 95-01-123, § 51-32-0300, filed 12/21/94, effective 6/30/95.] Repealed by 98-02-056, filed 1/6/98, effective 7/1/98. Statutory Authority: RCW 19.27.031 and 19.27.074.
51-30-93116	Section 93116. [Statutory Authority: Chapters 19.27 and 70.92 RCW. 95-01-129, § 51-30-93116, filed 12/21/94, effective 6/30/95.] Repealed by 98-02-054, filed 1/6/98, effective 7/1/98. Statutory Authority: RCW 19.27.031 and 19.27.074.	51-32-0327	Section 327—Room heaters and unvented decorative gas logs and fireplaces. [Statutory Authority: Chapter 19.27 RCW. 95-01-123, § 51-32-0327, filed 12/21/94, effective 6/30/95.] Repealed by 98-02-056, filed 1/6/98, effective 7/1/98. Statutory Authority: RCW 19.27.031 and 19.27.074.
51-30-93117	Section 93117. [Statutory Authority: Chapters 19.27 and 70.92 RCW. 95-01-129, § 51-30-93117, filed 12/21/94, effective 6/30/95.] Repealed by 98-02-054, filed 1/6/98, effective 7/1/98. Statutory Authority: RCW 19.27.031 and 19.27.074.	51-32-0500	Chapter 5—Exhaust systems. [Statutory Authority: Chapter 19.27 RCW. 95-01-123, § 51-32-0500, filed 12/21/94, effective 6/30/95.] Repealed by 98-02-056, filed 1/6/98, effective 7/1/98. Statutory Authority: RCW 19.27.031 and 19.27.074.
51-30-93118	Section 93118. [Statutory Authority: Chapters 19.27 and 70.92 RCW. 95-01-129, § 51-30-93118, filed 12/21/94, effective 6/30/95.] Repealed by 98-02-054, filed 1/6/98, effective 7/1/98. Statutory Authority: RCW 19.27.031 and 19.27.074.	51-32-0504	Section 504—Environmental air ducts. [Statutory Authority: Chapter 19.27 RCW. 95-01-123, § 51-32-0504, filed 12/21/94, effective 6/30/95.] Repealed by 98-02-056, filed 1/6/98, effective 7/1/98. Statutory Authority: RCW 19.27.031 and 19.27.074.
51-30-93119	Section 93119. [Statutory Authority: Chapters 19.27 and 70.92 RCW. 95-01-129, § 51-30-93119, filed 12/21/94, effective 6/30/95.] Repealed by 98-02-054, filed 1/6/98, effective 7/1/98. Statutory Authority: RCW 19.27.031 and 19.27.074.	51-32-0600	Chapter 6—Duct systems. [Statutory Authority: Chapter 19.27 RCW. 95-01-123, § 51-32-0600, filed 12/21/94, effective 6/30/95.] Repealed by 98-02-056, filed 1/6/98, effective 7/1/98. Statutory Authority: RCW 19.27.031 and 19.27.074.
51-30-93120	Section 93120. [Statutory Authority: Chapters 19.27 and 70.92 RCW. 95-01-129, § 51-30-93120, filed 12/21/94, effective 6/30/95.] Repealed by 98-02-054, filed 1/6/98, effective 7/1/98. Statutory Authority: RCW 19.27.031 and 19.27.074.	51-32-0601	Section 601—Scope. [Statutory Authority: Chapter 19.27 RCW. 95-01-123, § 51-32-0601, filed 12/21/94, effective 6/30/95.] Repealed by 98-02-056, filed 1/6/98, effective 7/1/98. Statutory Authority: RCW 19.27.031 and 19.27.074.
	Chapter 51-32	51-32-0605	Section 605—Dampers in duct systems. [Statutory Authority: Chapter 19.27 RCW. 95-01-123, § 51-32-0605, filed 12/21/94, effective 6/30/95.] Repealed by 98-02-056, filed 1/6/98, effective 7/1/98. Statutory Authority: RCW 19.27.031 and 19.27.074.
	STATE BUILDING CODE ADOPTION AND AMENDMENT OF THE 1994 EDITION OF THE UNIFORM MECHANICAL CODE (Replaced by chapter 51-42 WAC)	51-32-1100	Refrigeration. [Statutory Authority: RCW 19.27.074. 97-01-135, § 51-32-1100, filed 12/19/96, effective 7/1/97.] Repealed by 98-02-056, filed 1/6/98, effective 7/1/98. Statutory Authority: RCW 19.27.031 and 19.27.074.
51-32-001	Authority. [Statutory Authority: Chapter 19.27 RCW. 95-01-123, § 51-32-001, filed 12/21/94, effective 6/30/95.] Repealed by 98-02-056, filed 1/6/98, effective 7/1/98. Statutory Authority: RCW 19.27.031 and 19.27.074.	51-32-1101	General. [Statutory Authority: RCW 19.27.074. 97-01-135, § 51-32-1101, filed 12/19/96, effective 7/1/97.]
51-32-002	Purpose. [Statutory Authority: Chapter 19.27 RCW. 95-01-123, § 51-32-002, filed 12/21/94, effective 6/30/95.]		

- 51-32-1102 Repealed by 98-02-056, filed 1/6/98, effective 7/1/98. Statutory Authority: RCW 19.27.031 and 19.27.074. System requirements. [Statutory Authority: RCW 19.27.074, 97-01-135, § 51-32-1102, filed 12/19/96, effective 7/1/97.] Repealed by 98-02-056, filed 1/6/98, effective 7/1/98. Statutory Authority: RCW 19.27.031 and 19.27.074.
- 51-32-1103 Refrigeration system classification. [Statutory Authority: RCW 19.27.074, 97-01-135, § 51-32-1103, filed 12/19/96, effective 7/1/97.] Repealed by 98-02-056, filed 1/6/98, effective 7/1/98. Statutory Authority: RCW 19.27.031 and 19.27.074.
- 51-32-1104 Refrigerant classification and system requirements. [Statutory Authority: RCW 19.27.074, 97-01-135, § 51-32-1104, filed 12/19/96, effective 7/1/97.] Repealed by 98-02-056, filed 1/6/98, effective 7/1/98. Statutory Authority: RCW 19.27.031 and 19.27.074.
- 51-32-1105 Machinery room, general requirements. [Statutory Authority: RCW 19.27.074, 97-01-135, § 51-32-1105, filed 12/19/96, effective 7/1/97.] Repealed by 98-02-056, filed 1/6/98, effective 7/1/98. Statutory Authority: RCW 19.27.031 and 19.27.074.
- 51-32-1106 Machinery room, special requirements. [Statutory Authority: RCW 19.27.074, 97-01-135, § 51-32-1106, filed 12/19/96, effective 7/1/97.] Repealed by 98-02-056, filed 1/6/98, effective 7/1/98. Statutory Authority: RCW 19.27.031 and 19.27.074.
- 51-32-1107 Refrigerant piping. [Statutory Authority: RCW 19.27.074, 97-01-135, § 51-32-1107, filed 12/19/96, effective 7/1/97.] Repealed by 98-02-056, filed 1/6/98, effective 7/1/98. Statutory Authority: RCW 19.27.031 and 19.27.074.
- 51-32-1108 Field test. [Statutory Authority: RCW 19.27.074, 97-01-135, § 51-32-1108, filed 12/19/96, effective 7/1/97.] Repealed by 98-02-056, filed 1/6/98, effective 7/1/98. Statutory Authority: RCW 19.27.031 and 19.27.074.
- 51-32-1300 Appendix B, Chapter 13—Fuel-gas piping. [Statutory Authority: Chapter 19.27 RCW, 95-01-123, § 51-32-1300, filed 12/21/94, effective 6/30/95.] Repealed by 98-02-056, filed 1/6/98, effective 7/1/98. Statutory Authority: RCW 19.27.031 and 19.27.074.
- 51-32-1312 Section 1312—Material for gas piping. [Statutory Authority: Chapter 19.27 RCW, 95-01-123, § 51-32-1312, filed 12/21/94, effective 6/30/95.] Repealed by 98-02-056, filed 1/6/98, effective 7/1/98. Statutory Authority: RCW 19.27.031 and 19.27.074.
- 51-32-1313 Section 1313—Installation of gas piping. [Statutory Authority: Chapter 19.27 RCW, 95-01-123, § 51-32-1313, filed 12/21/94, effective 6/30/95.] Repealed by 98-02-056, filed 1/6/98, effective 7/1/98. Statutory Authority: RCW 19.27.031 and 19.27.074.
- Chapter 51-34
STATE BUILDING CODE ADOPTION AND AMENDMENT OF
THE 1994 EDITION OF THE UNIFORM FIRE CODE
(Replaced by chapter 51-44 WAC)**
- 51-34-001 Authority. [Statutory Authority: Chapter 19.27 RCW, 95-01-125, § 51-34-001, filed 12/21/94, effective 6/30/95.] Repealed by 98-02-053, filed 1/6/98, effective 7/1/98. Statutory Authority: RCW 19.27.031 and 19.27.074.
- 51-34-002 Purpose. [Statutory Authority: Chapter 19.27 RCW, 95-01-125, § 51-34-002, filed 12/21/94, effective 6/30/95.] Repealed by 98-02-053, filed 1/6/98, effective 7/1/98. Statutory Authority: RCW 19.27.031 and 19.27.074.
- 51-34-003 Uniform Fire Code. [Statutory Authority: Chapter 19.27 RCW, 95-01-125, § 51-34-003, filed 12/21/94, effective 6/30/95.] Repealed by 98-02-053, filed 1/6/98, effective 7/1/98. Statutory Authority: RCW 19.27.031 and 19.27.074.
- 51-34-007 Exceptions. [Statutory Authority: Chapter 19.27 RCW, 95-01-125, § 51-34-007, filed 12/21/94, effective 6/30/95.] Repealed by 98-02-053, filed 1/6/98, effective 7/1/98. Statutory Authority: RCW 19.27.031 and 19.27.074.
- 51-34-008 Implementation. [Statutory Authority: Chapter 19.27 RCW, 95-01-125, § 51-34-008, filed 12/21/94, effective 6/30/95.] Repealed by 98-02-053, filed 1/6/98, effective 7/1/98. Statutory Authority: RCW 19.27.031 and 19.27.074.
- 51-34-0200 Article 2—Definitions and abbreviations. [Statutory Authority: Chapter 19.27 RCW, 95-01-125, § 51-34-0200, filed 12/21/94, effective 6/30/95.] Repealed by 98-02-053, filed 1/6/98, effective 7/1/98. Statutory Authority: RCW 19.27.031 and 19.27.074.
- 51-34-0206 Section 206—E. [Statutory Authority: Chapter 19.27 RCW, 95-01-125, § 51-34-0206, filed 12/21/94, effective 6/30/95.] Repealed by 98-02-053, filed 1/6/98, effective 7/1/98. Statutory Authority: RCW 19.27.031 and 19.27.074.
- 51-34-0216 Section 216—O. [Statutory Authority: Chapter 19.27 RCW, 95-01-125, § 51-34-0216, filed 12/21/94, effective 6/30/95.] Repealed by 98-02-053, filed 1/6/98, effective 7/1/98. Statutory Authority: RCW 19.27.031 and 19.27.074.
- 51-34-0219 Section 219—R. [Statutory Authority: Chapter 19.27 RCW, 95-01-125, § 51-34-0219, filed 12/21/94, effective 6/30/95.] Repealed by 98-02-053, filed 1/6/98, effective 7/1/98. Statutory Authority: RCW 19.27.031 and 19.27.074.
- 51-34-0223 Section 223—V. [Statutory Authority: Chapter 19.27 RCW, 95-01-125, § 51-34-0223, filed 12/21/94, effective 6/30/95.] Repealed by 98-02-053, filed 1/6/98, effective 7/1/98. Statutory Authority: RCW 19.27.031 and 19.27.074.
- 51-34-0900 Article 9—Fire department access and water supply. [Statutory Authority: Chapter 19.27 RCW, 95-01-125, § 51-34-0900, filed 12/21/94, effective 6/30/95.] Repealed by 98-02-053, filed 1/6/98, effective 7/1/98. Statutory Authority: RCW 19.27.031 and 19.27.074.
- 51-34-0901 Section 901—General. [Statutory Authority: Chapter 19.27 RCW, 95-01-125, § 51-34-0901, filed 12/21/94, effective 6/30/95.] Repealed by 98-02-053, filed 1/6/98, effective 7/1/98. Statutory Authority: RCW 19.27.031 and 19.27.074.
- 51-34-0902 Section 902—Fire department access. [Statutory Authority: Chapter 19.27 RCW, 95-01-125, § 51-34-0902, filed 12/21/94, effective 6/30/95.] Repealed by 98-02-053, filed 1/6/98, effective 7/1/98. Statutory Authority: RCW 19.27.031 and 19.27.074.
- 51-34-1000 Article 10—Fire-protection systems and equipment. [Statutory Authority: Chapter 19.27 RCW, 95-01-125, § 51-34-1000, filed 12/21/94, effective 6/30/95.] Repealed by 98-02-053, filed 1/6/98, effective 7/1/98. Statutory Authority: RCW 19.27.031 and 19.27.074.
- 51-34-1003 Section 1003—Fire-extinguishing systems. [Statutory Authority: Chapter 19.27 RCW, 95-01-125, § 51-34-1003, filed 12/21/94, effective 6/30/95.] Repealed by 98-02-053, filed 1/6/98, effective 7/1/98. Statutory Authority: RCW 19.27.031 and 19.27.074.
- 51-34-1007 Section 1007—Fire alarm systems. [Statutory Authority: Chapter 19.27 RCW, 95-01-125, § 51-34-1007, filed 12/21/94, effective 6/30/95.] Repealed by 98-02-053, filed 1/6/98, effective 7/1/98. Statutory Authority: RCW 19.27.031 and 19.27.074.
- 51-34-2500 Article 25—Places of assembly. [Statutory Authority: Chapter 19.27 RCW, 95-01-125, § 51-34-2500, filed 12/21/94, effective 6/30/95.] Repealed by 98-02-053, filed 1/6/98, effective 7/1/98. Statutory Authority: RCW 19.27.031 and 19.27.074.
- 51-34-2501 Section 2501—General. [Statutory Authority: Chapter 19.27 RCW, 95-01-125, § 51-34-2501, filed 12/21/94, effective 6/30/95.] Repealed by 98-02-053, filed 1/6/98, effective 7/1/98. Statutory Authority: RCW 19.27.031 and 19.27.074.
- 51-34-5200 Article 52—Motor vehicle fuel-dispensing stations. [Statutory Authority: Chapter 19.27 RCW, 95-01-125, § 51-34-5200, filed 12/21/94, effective 6/30/95.] Repealed by 98-02-053, filed 1/6/98, effective 7/1/98. Statutory Authority: RCW 19.27.031 and 19.27.074.
- 51-34-5201 Section 5201—General. [Statutory Authority: Chapter 19.27 RCW, 95-01-125, § 51-34-5201, filed 12/21/94, effective 6/30/95.] Repealed by 98-02-053, filed 1/6/98, effective 7/1/98. Statutory Authority: RCW 19.27.031 and 19.27.074.
- 51-34-5204 Section 5204—Compressed natural gas motor vehicle fuel-dispensing stations. [Statutory Authority: Chapter 19.27 RCW, 95-01-125, § 51-34-5204, filed 12/21/94, effective 6/30/95.] Repealed by 98-02-053, filed 1/6/98, effective 7/1/98. Statutory Authority: RCW 19.27.031 and 19.27.074.
- 51-34-6100 Article 61—Oil-burning equipment. [Statutory Authority: Chapter 19.27 RCW, 95-01-125, § 51-34-6100, filed 12/21/94, effective 6/30/95.] Repealed by 98-02-053, filed 1/6/98, effective 7/1/98. Statutory Authority: RCW 19.27.031 and 19.27.074.

51-34-6103	Section 6103—Permits. [Statutory Authority: Chapter 19.27 RCW. 95-01-125, § 51-34-6103, filed 12/21/94, effective 6/30/95.] Repealed by 98-02-053, filed 1/6/98, effective 7/1/98. Statutory Authority: RCW 19.27.031 and 19.27.074.	51-34-6313	Detection and alarm systems. [Statutory Authority: RCW 19.27.074. 97-01-135, § 51-34-6313, filed 12/19/96, effective 7/1/97.] Repealed by 98-02-053, filed 1/6/98, effective 7/1/98. Statutory Authority: RCW 19.27.031 and 19.27.074.
51-34-6104	Section 6104—Electrical wiring and equipment. [Statutory Authority: Chapter 19.27 RCW. 95-01-125, § 51-34-6104, filed 12/21/94, effective 6/30/95.] Repealed by 98-02-053, filed 1/6/98, effective 7/1/98. Statutory Authority: RCW 19.27.031 and 19.27.074.	51-34-6314	Refrigeration machinery room equipment and controls. [Statutory Authority: RCW 19.27.074. 97-01-135, § 51-34-6314, filed 12/19/96, effective 7/1/97.] Repealed by 98-02-053, filed 1/6/98, effective 7/1/98. Statutory Authority: RCW 19.27.031 and 19.27.074.
51-34-6105	Section 6105—Fuel oil. [Statutory Authority: Chapter 19.27 RCW. 95-01-125, § 51-34-6105, filed 12/21/94, effective 6/30/95.] Repealed by 98-02-053, filed 1/6/98, effective 7/1/98. Statutory Authority: RCW 19.27.031 and 19.27.074.	51-34-6315	Refrigerant control valves. [Statutory Authority: RCW 19.27.074. 97-01-135, § 51-34-6315, filed 12/19/96, effective 7/1/97.] Repealed by 98-02-053, filed 1/6/98, effective 7/1/98. Statutory Authority: RCW 19.27.031 and 19.27.074.
51-34-6106	Section 6106—Abandonment of tanks. [Statutory Authority: Chapter 19.27 RCW. 95-01-125, § 51-34-6106, filed 12/21/94, effective 6/30/95.] Repealed by 98-02-053, filed 1/6/98, effective 7/1/98. Statutory Authority: RCW 19.27.031 and 19.27.074.	51-34-6316	Protection from mechanical damage. [Statutory Authority: RCW 19.27.074. 97-01-135, § 51-34-6316, filed 12/19/96, effective 7/1/97.] Repealed by 98-02-053, filed 1/6/98, effective 7/1/98. Statutory Authority: RCW 19.27.031 and 19.27.074.
51-34-6107	Section 6107—Portable unvented oil-burning heating appliances and unvented decorative gas logs and fireplaces. [Statutory Authority: Chapter 19.27 RCW. 95-01-125, § 51-34-6107, filed 12/21/94, effective 6/30/95.] Repealed by 98-02-053, filed 1/6/98, effective 7/1/98. Statutory Authority: RCW 19.27.031 and 19.27.074.	51-34-6317	Electrical. [Statutory Authority: RCW 19.27.074. 97-01-135, § 51-34-6317, filed 12/19/96, effective 7/1/97.] Repealed by 98-02-053, filed 1/6/98, effective 7/1/98. Statutory Authority: RCW 19.27.031 and 19.27.074.
51-34-6301	Scope. [Statutory Authority: RCW 19.27.074. 97-01-135, § 51-34-6301, filed 12/19/96, effective 7/1/97.] Repealed by 98-02-053, filed 1/6/98, effective 7/1/98. Statutory Authority: RCW 19.27.031 and 19.27.074.	51-34-6318	Instructions. [Statutory Authority: RCW 19.27.074. 97-01-135, § 51-34-6318, filed 12/19/96, effective 7/1/97.] Repealed by 98-02-053, filed 1/6/98, effective 7/1/98. Statutory Authority: RCW 19.27.031 and 19.27.074.
51-34-6302	Classification. [Statutory Authority: RCW 19.27.074. 97-01-135, § 51-34-6302, filed 12/19/96, effective 7/1/97.] Repealed by 98-02-053, filed 1/6/98, effective 7/1/98. Statutory Authority: RCW 19.27.031 and 19.27.074.	51-34-6319	Emergency signs and labels. [Statutory Authority: RCW 19.27.074. 97-01-135, § 51-34-6319, filed 12/19/96, effective 7/1/97.] Repealed by 98-02-053, filed 1/6/98, effective 7/1/98. Statutory Authority: RCW 19.27.031 and 19.27.074.
51-34-6303	Definitions. [Statutory Authority: RCW 19.27.074. 97-01-135, § 51-34-6303, filed 12/19/96, effective 7/1/97.] Repealed by 98-02-053, filed 1/6/98, effective 7/1/98. Statutory Authority: RCW 19.27.031 and 19.27.074.	51-34-6320	Testing of equipment. [Statutory Authority: RCW 19.27.074. 97-01-135, § 51-34-6320, filed 12/19/96, effective 7/1/97.] Repealed by 98-02-053, filed 1/6/98, effective 7/1/98. Statutory Authority: RCW 19.27.031 and 19.27.074.
51-34-6304	Permits and plans. [Statutory Authority: RCW 19.27.074. 97-01-135, § 51-34-6304, filed 12/19/96, effective 7/1/97.] Repealed by 98-02-053, filed 1/6/98, effective 7/1/98. Statutory Authority: RCW 19.27.031 and 19.27.074.	51-34-6321	Notification of discharges. [Statutory Authority: RCW 19.27.074. 97-01-135, § 51-34-6321, filed 12/19/96, effective 7/1/97.] Repealed by 98-02-053, filed 1/6/98, effective 7/1/98. Statutory Authority: RCW 19.27.031 and 19.27.074.
51-34-6305	Installation and maintenance. [Statutory Authority: RCW 19.27.074. 97-01-135, § 51-34-6305, filed 12/19/96, effective 7/1/97.] Repealed by 98-02-053, filed 1/6/98, effective 7/1/98. Statutory Authority: RCW 19.27.031 and 19.27.074.	51-34-6322	Storage, handling and use. [Statutory Authority: RCW 19.27.074. 97-01-135, § 51-34-6322, filed 12/19/96, effective 7/1/97.] Repealed by 98-02-053, filed 1/6/98, effective 7/1/98. Statutory Authority: RCW 19.27.031 and 19.27.074.
51-34-6306	Access. [Statutory Authority: RCW 19.27.074. 97-01-135, § 51-34-6306, filed 12/19/96, effective 7/1/97.] Repealed by 98-02-053, filed 1/6/98, effective 7/1/98. Statutory Authority: RCW 19.27.031 and 19.27.074.	51-34-6323	Changing of refrigerant type. [Statutory Authority: RCW 19.27.074. 97-01-135, § 51-34-6323, filed 12/19/96, effective 7/1/97.] Repealed by 98-02-053, filed 1/6/98, effective 7/1/98. Statutory Authority: RCW 19.27.031 and 19.27.074.
51-34-6307	Emergency control box. [Statutory Authority: RCW 19.27.074. 97-01-135, § 51-34-6307, filed 12/19/96, effective 7/1/97.] Repealed by 98-02-053, filed 1/6/98, effective 7/1/98. Statutory Authority: RCW 19.27.031 and 19.27.074.	51-34-6324	Records. [Statutory Authority: RCW 19.27.074. 97-01-135, § 51-34-6324, filed 12/19/96, effective 7/1/97.] Repealed by 98-02-053, filed 1/6/98, effective 7/1/98. Statutory Authority: RCW 19.27.031 and 19.27.074.
51-34-6308	Treatment and flaring systems for discharge. [Statutory Authority: RCW 19.27.074. 97-01-135, § 51-34-6308, filed 12/19/96, effective 7/1/97.] Repealed by 98-02-053, filed 1/6/98, effective 7/1/98. Statutory Authority: RCW 19.27.031 and 19.27.074.	51-34-7800	Article 78—Fireworks and pyrotechnic special effects material. [Statutory Authority: Chapter 19.27 RCW. 95-01-125, § 51-34-7800, filed 12/21/94, effective 6/30/95.] Repealed by 98-02-053, filed 1/6/98, effective 7/1/98. Statutory Authority: RCW 19.27.031 and 19.27.074.
51-34-6309	Ammonia discharge. [Statutory Authority: RCW 19.27.074. 97-01-135, § 51-34-6309, filed 12/19/96, effective 7/1/97.] Repealed by 98-02-053, filed 1/6/98, effective 7/1/98. Statutory Authority: RCW 19.27.031 and 19.27.074.	51-34-7802	Section 7802—Fireworks. [Statutory Authority: Chapter 19.27 RCW. 95-01-125, § 51-34-7802, filed 12/21/94, effective 6/30/95.] Repealed by 98-02-053, filed 1/6/98, effective 7/1/98. Statutory Authority: RCW 19.27.031 and 19.27.074.
51-34-6310	Refrigeration machinery rooms. [Statutory Authority: RCW 19.27.074. 97-01-135, § 51-34-6310, filed 12/19/96, effective 7/1/97.] Repealed by 98-02-053, filed 1/6/98, effective 7/1/98. Statutory Authority: RCW 19.27.031 and 19.27.074.	51-34-7900	Article 79—Flammable and combustible liquids. [Statutory Authority: Chapter 19.27 RCW. 95-01-125, § 51-34-7900, filed 12/21/94, effective 6/30/95.] Repealed by 98-02-053, filed 1/6/98, effective 7/1/98. Statutory Authority: RCW 19.27.031 and 19.27.074.
51-34-6311	Refrigeration machinery room ventilation. [Statutory Authority: RCW 19.27.074. 97-01-135, § 51-34-6311, filed 12/19/96, effective 7/1/97.] Repealed by 98-02-053, filed 1/6/98, effective 7/1/98. Statutory Authority: RCW 19.27.031 and 19.27.074.	51-34-7902	Section 7902—Storage. [Statutory Authority: Chapter 19.27 RCW. 95-01-125, § 51-34-7902, filed 12/21/94, effective 6/30/95.] Repealed by 98-02-053, filed 1/6/98, effective 7/1/98. Statutory Authority: RCW 19.27.031 and 19.27.074.
51-34-6312	Refrigerated process and storage areas. [Statutory Authority: RCW 19.27.074. 97-01-135, § 51-34-6312, filed 12/19/96, effective 7/1/97.] Repealed by 98-02-053, filed 1/6/98, effective 7/1/98. Statutory Authority: RCW 19.27.031 and 19.27.074.	51-34-7904	Section 7904—Special operations. [Statutory Authority: Chapter 19.27 RCW. 95-01-125, § 51-34-7904, filed 12/21/94, effective 6/30/95.] Repealed by 98-02-053, filed 1/6/98, effective 7/1/98. Statutory Authority: RCW 19.27.031 and 19.27.074.

51-34-8000	Article 80—Hazardous materials. [Statutory Authority: Chapter 19.27 RCW. 95-01-125, § 51-34-8000, filed 12/21/94, effective 6/30/95.] Repealed by 98-02-053, filed 1/6/98, effective 7/1/98. Statutory Authority: RCW 19.27.031 and 19.27.074.	51-35-008	7/1/98. Statutory Authority: RCW 19.27.031 and 19.27.074.
51-34-8001	Section 8001—General. [Statutory Authority: Chapter 19.27 RCW. 95-01-125, § 51-34-8001, filed 12/21/94, effective 6/30/95.] Repealed by 98-02-053, filed 1/6/98, effective 7/1/98. Statutory Authority: RCW 19.27.031 and 19.27.074.	51-35-52000	Implementation. [Statutory Authority: Chapter 19.27 RCW. 95-01-125, § 51-35-008, filed 12/21/94, effective 6/30/95.] Repealed by 98-02-053, filed 1/6/98, effective 7/1/98. Statutory Authority: RCW 19.27.031 and 19.27.074.
51-34-8003	Section 8003—Storage. [Statutory Authority: Chapter 19.27 RCW. 95-01-125, § 51-34-8003, filed 12/21/94, effective 6/30/95.] Repealed by 98-02-053, filed 1/6/98, effective 7/1/98. Statutory Authority: RCW 19.27.031 and 19.27.074.	51-35-52400	Uniform Fire Code Standard 52-1 compressed natural gas (CNG) vehicular fuel systems. [Statutory Authority: Chapter 19.27 RCW. 95-01-125, § 51-35-52000, filed 12/21/94, effective 6/30/95.] Repealed by 98-02-053, filed 1/6/98, effective 7/1/98. Statutory Authority: RCW 19.27.031 and 19.27.074.
51-34-9100	Appendix II-F—Protected aboveground tanks for motor vehicle fuel-dispensing stations outside buildings. [Statutory Authority: Chapter 19.27 RCW. 95-01-125, § 51-34-9100, filed 12/21/94, effective 6/30/95.] Repealed by 98-02-053, filed 1/6/98, effective 7/1/98. Statutory Authority: RCW 19.27.031 and 19.27.074.	51-35-52440	Chapter 4—CNG compression, storage, and dispensing systems. [Statutory Authority: Chapter 19.27 RCW. 95-01-125, § 51-35-52400, filed 12/21/94, effective 6/30/95.] Repealed by 98-02-053, filed 1/6/98, effective 7/1/98. Statutory Authority: RCW 19.27.031 and 19.27.074.
51-34-9101	Section 1—Scope. [Statutory Authority: Chapter 19.27 RCW. 95-01-125, § 51-34-9101, filed 12/21/94, effective 6/30/95.] Repealed by 98-02-053, filed 1/6/98, effective 7/1/98. Statutory Authority: RCW 19.27.031 and 19.27.074.	51-35-52440	Section 52440. [Statutory Authority: Chapter 19.27 RCW. 95-01-125, § 51-35-52440, filed 12/21/94, effective 6/30/95.] Repealed by 98-02-053, filed 1/6/98, effective 7/1/98. Statutory Authority: RCW 19.27.031 and 19.27.074.
51-34-9102	Section 2—Definitions. [Statutory Authority: Chapter 19.27 RCW. 95-01-125, § 51-34-9102, filed 12/21/94, effective 6/30/95.] Repealed by 98-02-053, filed 1/6/98, effective 7/1/98. Statutory Authority: RCW 19.27.031 and 19.27.074.	51-35-52441	Section 52441. [Statutory Authority: Chapter 19.27 RCW. 95-01-125, § 51-35-52441, filed 12/21/94, effective 6/30/95.] Repealed by 98-02-053, filed 1/6/98, effective 7/1/98. Statutory Authority: RCW 19.27.031 and 19.27.074.
51-34-9103	Section 3—Permits and plans. [Statutory Authority: Chapter 19.27 RCW. 95-01-125, § 51-34-9103, filed 12/21/94, effective 6/30/95.] Repealed by 98-02-053, filed 1/6/98, effective 7/1/98. Statutory Authority: RCW 19.27.031 and 19.27.074.	51-35-52442	Section 52442. [Statutory Authority: Chapter 19.27 RCW. 95-01-125, § 51-35-52442, filed 12/21/94, effective 6/30/95.] Repealed by 98-02-053, filed 1/6/98, effective 7/1/98. Statutory Authority: RCW 19.27.031 and 19.27.074.
51-34-9104	Section 4—Tank design. [Statutory Authority: Chapter 19.27 RCW. 95-01-125, § 51-34-9104, filed 12/21/94, effective 6/30/95.] Repealed by 98-02-053, filed 1/6/98, effective 7/1/98. Statutory Authority: RCW 19.27.031 and 19.27.074.	51-35-52500	Chapter 5—Vehicle fueling appliances. [Statutory Authority: Chapter 19.27 RCW. 95-01-125, § 51-35-52500, filed 12/21/94, effective 6/30/95.] Repealed by 98-02-053, filed 1/6/98, effective 7/1/98. Statutory Authority: RCW 19.27.031 and 19.27.074.
51-34-9105	Section 5—Installation of tanks. [Statutory Authority: Chapter 19.27 RCW. 95-01-125, § 51-34-9105, filed 12/21/94, effective 6/30/95.] Repealed by 98-02-053, filed 1/6/98, effective 7/1/98. Statutory Authority: RCW 19.27.031 and 19.27.074.	51-35-52510	Section 52510. [Statutory Authority: Chapter 19.27 RCW. 95-01-125, § 51-35-52510, filed 12/21/94, effective 6/30/95.] Repealed by 98-02-053, filed 1/6/98, effective 7/1/98. Statutory Authority: RCW 19.27.031 and 19.27.074.
51-34-9106	Section 6—Installation of dispensing and piping systems. [Statutory Authority: Chapter 19.27 RCW. 95-01-125, § 51-34-9106, filed 12/21/94, effective 6/30/95.] Repealed by 98-02-053, filed 1/6/98, effective 7/1/98. Statutory Authority: RCW 19.27.031 and 19.27.074.	51-35-52520	Section 52520. [Statutory Authority: Chapter 19.27 RCW. 95-01-125, § 51-35-52520, filed 12/21/94, effective 6/30/95.] Repealed by 98-02-053, filed 1/6/98, effective 7/1/98. Statutory Authority: RCW 19.27.031 and 19.27.074.
51-34-9107	Section 7—Parking of tank vehicles. [Statutory Authority: Chapter 19.27 RCW. 95-01-125, § 51-34-9107, filed 12/21/94, effective 6/30/95.] Repealed by 98-02-053, filed 1/6/98, effective 7/1/98. Statutory Authority: RCW 19.27.031 and 19.27.074.	51-35-52530	Section 52530. [Statutory Authority: Chapter 19.27 RCW. 95-01-125, § 51-35-52530, filed 12/21/94, effective 6/30/95.] Repealed by 98-02-053, filed 1/6/98, effective 7/1/98. Statutory Authority: RCW 19.27.031 and 19.27.074.
51-34-9108	Section 8—Maintenance. [Statutory Authority: Chapter 19.27 RCW. 95-01-125, § 51-34-9108, filed 12/21/94, effective 6/30/95.] Repealed by 98-02-053, filed 1/6/98, effective 7/1/98. Statutory Authority: RCW 19.27.031 and 19.27.074.	51-35-52540	Section 52540. [Statutory Authority: Chapter 19.27 RCW. 95-01-125, § 51-35-52540, filed 12/21/94, effective 6/30/95.] Repealed by 98-02-053, filed 1/6/98, effective 7/1/98. Statutory Authority: RCW 19.27.031 and 19.27.074.
	Chapter 51-35	51-35-52550	Section 52550. [Statutory Authority: Chapter 19.27 RCW. 95-01-125, § 51-35-52550, filed 12/21/94, effective 6/30/95.] Repealed by 98-02-053, filed 1/6/98, effective 7/1/98. Statutory Authority: RCW 19.27.031 and 19.27.074.
	STATE BUILDING CODE ADOPTION AND AMENDMENT OF THE 1994 EDITION OF THE UNIFORM FIRE CODE STANDARDS (Replaced by chapter 51-45 WAC)	51-35-52560	Section 52560. [Statutory Authority: Chapter 19.27 RCW. 95-01-125, § 51-35-52560, filed 12/21/94, effective 6/30/95.] Repealed by 98-02-053, filed 1/6/98, effective 7/1/98. Statutory Authority: RCW 19.27.031 and 19.27.074.
51-35-001	Authority. [Statutory Authority: Chapter 19.27 RCW. 95-01-125, § 51-35-001, filed 12/21/94, effective 6/30/95.] Repealed by 98-02-053, filed 1/6/98, effective 7/1/98. Statutory Authority: RCW 19.27.031 and 19.27.074.	51-35-52570	Section 52570. [Statutory Authority: Chapter 19.27 RCW. 95-01-125, § 51-35-52570, filed 12/21/94, effective 6/30/95.] Repealed by 98-02-053, filed 1/6/98, effective 7/1/98. Statutory Authority: RCW 19.27.031 and 19.27.074.
51-35-002	Purpose. [Statutory Authority: Chapter 19.27 RCW. 95-01-125, § 51-35-002, filed 12/21/94, effective 6/30/95.] Repealed by 98-02-053, filed 1/6/98, effective 7/1/98. Statutory Authority: RCW 19.27.031 and 19.27.074.	51-35-52580	Section 52580. [Statutory Authority: Chapter 19.27 RCW. 95-01-125, § 51-35-52580, filed 12/21/94, effective 6/30/95.] Repealed by 98-02-053, filed 1/6/98, effective 7/1/98. Statutory Authority: RCW 19.27.031 and 19.27.074.
51-35-003	Uniform Fire Code Standards. [Statutory Authority: Chapter 19.27 RCW. 95-01-125, § 51-35-003, filed 12/21/94, effective 6/30/95.] Repealed by 98-02-053, filed 1/6/98, effective 7/1/98. Statutory Authority: RCW 19.27.031 and 19.27.074.	51-35-52590	Section 52590. [Statutory Authority: Chapter 19.27 RCW. 95-01-125, § 51-35-52590, filed 12/21/94, effective 6/30/95.] Repealed by 98-02-053, filed 1/6/98, effective 7/1/98. Statutory Authority: RCW 19.27.031 and 19.27.074.
51-35-007	Exceptions. [Statutory Authority: Chapter 19.27 RCW. 95-01-125, § 51-35-007, filed 12/21/94, effective 6/30/95.] Repealed by 98-02-053, filed 1/6/98, effective 7/1/98. Statutory Authority: RCW 19.27.031 and 19.27.074.		

- filed 1/6/98, effective 7/1/98.] Repealed by 02-01-114, filed 12/18/01, effective 7/1/02. Statutory Authority: RCW 19.27.031, 19.27.074.
- 51-46-0513 Limitations. [Statutory Authority: RCW 19.27.031 and 19.27.074. 98-02-055, § 51-46-0513, filed 1/6/98, effective 7/1/98.] Repealed by 02-01-114, filed 12/18/01, effective 7/1/02. Statutory Authority: RCW 19.27.031, 19.27.074.
- 51-46-0514 Vent connectors. [Statutory Authority: RCW 19.27.031 and 19.27.074. 98-02-055, § 51-46-0514, filed 1/6/98, effective 7/1/98.] Repealed by 02-01-114, filed 12/18/01, effective 7/1/02. Statutory Authority: RCW 19.27.031, 19.27.074.
- 51-46-0515 Location and support of venting system. [Statutory Authority: RCW 19.27.031 and 19.27.074. 98-02-055, § 51-46-0515, filed 1/6/98, effective 7/1/98.] Repealed by 02-01-114, filed 12/18/01, effective 7/1/02. Statutory Authority: RCW 19.27.031, 19.27.074.
- 51-46-0516 Length pitch and clearance. [Statutory Authority: RCW 19.27.031 and 19.27.074. 98-02-055, § 51-46-0516, filed 1/6/98, effective 7/1/98.] Repealed by 02-01-114, filed 12/18/01, effective 7/1/02. Statutory Authority: RCW 19.27.031, 19.27.074.
- 51-46-0517 Vent termination. [Statutory Authority: RCW 19.27.031 and 19.27.074. 98-02-055, § 51-46-0517, filed 1/6/98, effective 7/1/98.] Repealed by 02-01-114, filed 12/18/01, effective 7/1/02. Statutory Authority: RCW 19.27.031, 19.27.074.
- 51-46-0518 Area of venting system. [Statutory Authority: RCW 19.27.031 and 19.27.074. 98-02-055, § 51-46-0518, filed 1/6/98, effective 7/1/98.] Repealed by 02-01-114, filed 12/18/01, effective 7/1/02. Statutory Authority: RCW 19.27.031, 19.27.074.
- 51-46-0519 Multiple appliance venting. [Statutory Authority: RCW 19.27.031 and 19.27.074. 98-02-055, § 51-46-0519, filed 1/6/98, effective 7/1/98.] Repealed by 02-01-114, filed 12/18/01, effective 7/1/02. Statutory Authority: RCW 19.27.031, 19.27.074.
- 51-46-0520 Existing venting system. [Statutory Authority: RCW 19.27.031 and 19.27.074. 98-02-055, § 51-46-0520, filed 1/6/98, effective 7/1/98.] Repealed by 02-01-114, filed 12/18/01, effective 7/1/02. Statutory Authority: RCW 19.27.031, 19.27.074.
- 51-46-0521 Draft hoods. [Statutory Authority: RCW 19.27.031 and 19.27.074. 98-02-055, § 51-46-0521, filed 1/6/98, effective 7/1/98.] Repealed by 02-01-114, filed 12/18/01, effective 7/1/02. Statutory Authority: RCW 19.27.031, 19.27.074.
- 51-46-0522 Gas venting into existing masonry chimneys. [Statutory Authority: RCW 19.27.031 and 19.27.074. 98-02-055, § 51-46-0522, filed 1/6/98, effective 7/1/98.] Repealed by 02-01-114, filed 12/18/01, effective 7/1/02. Statutory Authority: RCW 19.27.031, 19.27.074.
- 51-46-0523 Installation. [Statutory Authority: RCW 19.27.031 and 19.27.074. 98-02-055, § 51-46-0523, filed 1/6/98, effective 7/1/98.] Repealed by 02-01-114, filed 12/18/01, effective 7/1/02. Statutory Authority: RCW 19.27.031, 19.27.074.
- 51-46-0524 Mechanical draft systems. [Statutory Authority: RCW 19.27.031 and 19.27.074. 98-02-055, § 51-46-0524, filed 1/6/98, effective 7/1/98.] Repealed by 02-01-114, filed 12/18/01, effective 7/1/02. Statutory Authority: RCW 19.27.031, 19.27.074.
- 51-46-0525 Venting through ventilating hoods and exhaust systems. [Statutory Authority: RCW 19.27.031 and 19.27.074. 98-02-055, § 51-46-0525, filed 1/6/98, effective 7/1/98.] Repealed by 02-01-114, filed 12/18/01, effective 7/1/02. Statutory Authority: RCW 19.27.031, 19.27.074.
- 51-46-0600 Water supply and distribution. [Statutory Authority: RCW 19.27.031 and 19.27.074. 98-02-055, § 51-46-0600, filed 1/6/98, effective 7/1/98.] Repealed by 02-01-114, filed 12/18/01, effective 7/1/02. Statutory Authority: RCW 19.27.031, 19.27.074.
- 51-46-0603 Cross-connection control. [Statutory Authority: RCW 19.27.031, 19.27.074. 01-02-097, § 51-46-0603, filed 1/3/01, effective 7/1/01; 98-02-055, § 51-46-0603, filed 1/6/98, effective 7/1/98.] Repealed by 02-01-114, filed 12/18/01, effective 7/1/02. Statutory Authority: RCW 19.27.031, 19.27.074.
- 51-46-0604 Materials. [Statutory Authority: RCW 19.27.031 and 19.27.074. 98-02-055, § 51-46-0604, filed 1/6/98, effective 7/1/98.] Repealed by 02-01-114, filed 12/18/01, effective 7/1/02. Statutory Authority: RCW 19.27.031, 19.27.074.
- 51-46-0608 Water pressure, pressure regulators, pressure relief valves, and vacuum relief valves. [Statutory Authority: RCW 19.27.031 and 19.27.074. 98-02-055, § 51-46-0608, filed 1/6/98, effective 7/1/98.] Repealed by 02-01-114, filed 12/18/01, effective 7/1/02. Statutory Authority: RCW 19.27.031, 19.27.074.
- 51-46-0609 Installation, testing, unions, and location. [Statutory Authority: RCW 19.27.031 and 19.27.074. 98-02-055, § 51-46-0609, filed 1/6/98, effective 7/1/98.] Repealed by 02-01-114, filed 12/18/01, effective 7/1/02. Statutory Authority: RCW 19.27.031, 19.27.074.
- 51-46-0610 Size of potable water piping. [Statutory Authority: RCW 19.27.031 and 19.27.074. 98-02-055, § 51-46-0610, filed 1/6/98, effective 7/1/98.] Repealed by 02-01-114, filed 12/18/01, effective 7/1/02. Statutory Authority: RCW 19.27.031, 19.27.074.
- 51-46-0700 Sanitary drainage. [Statutory Authority: RCW 19.27.031 and 19.27.074. 98-02-055, § 51-46-0700, filed 1/6/98, effective 7/1/98.] Repealed by 02-01-114, filed 12/18/01, effective 7/1/02. Statutory Authority: RCW 19.27.031, 19.27.074.
- 51-46-0701 Materials. [Statutory Authority: RCW 19.27.031 and 19.27.074. 98-02-055, § 51-46-0701, filed 1/6/98, effective 7/1/98.] Repealed by 02-01-114, filed 12/18/01, effective 7/1/02. Statutory Authority: RCW 19.27.031, 19.27.074.
- 51-46-0704 Fixture connections (drainage). [Statutory Authority: RCW 19.27.031 and 19.27.074. 98-02-055, § 51-46-0704, filed 1/6/98, effective 7/1/98.] Repealed by 02-01-114, filed 12/18/01, effective 7/1/02. Statutory Authority: RCW 19.27.031, 19.27.074.
- 51-46-0710 Drainage of fixtures located below the next upstream manhole or below the main sewer level. [Statutory Authority: RCW 19.27.031 and 19.27.074. 98-02-055, § 51-46-0710, filed 1/6/98, effective 7/1/98.] Repealed by 02-01-114, filed 12/18/01, effective 7/1/02. Statutory Authority: RCW 19.27.031, 19.27.074.
- 51-46-0713 Building sewers. [Statutory Authority: RCW 19.27.031 and 19.27.074. 98-02-055, § 51-46-0713, filed 1/6/98, effective 7/1/98.] Repealed by 02-01-114, filed 12/18/01, effective 7/1/02. Statutory Authority: RCW 19.27.031, 19.27.074.
- 51-46-0793 Table 7-3 Drainage fixture unit values. [Statutory Authority: RCW 19.27.031 and 19.27.074. 98-02-055, § 51-46-0793, filed 1/6/98, effective 7/1/98.] Repealed by 02-01-114, filed 12/18/01, effective 7/1/02. Statutory Authority: RCW 19.27.031, 19.27.074.
- 51-46-0800 Indirect wastes. [Statutory Authority: RCW 19.27.031 and 19.27.074. 98-02-055, § 51-46-0800, filed 1/6/98, effective 7/1/98.] Repealed by 02-01-114, filed 12/18/01, effective 7/1/02. Statutory Authority: RCW 19.27.031, 19.27.074.
- 51-46-0810 Steam and hot water drainage condensers and sumps. [Statutory Authority: RCW 19.27.031 and 19.27.074. 98-02-055, § 51-46-0810, filed 1/6/98, effective 7/1/98.] Repealed by 02-01-114, filed 12/18/01, effective 7/1/02. Statutory Authority: RCW 19.27.031, 19.27.074.
- 51-46-0814 Refrigeration wastes. [Statutory Authority: RCW 19.27.031 and 19.27.074. 98-02-055, § 51-46-0814, filed 1/6/98, effective 7/1/98.] Repealed by 02-01-114, filed 12/18/01, effective 7/1/02. Statutory Authority: RCW 19.27.031, 19.27.074.
- 51-46-0815 Air-conditioning equipment. [Statutory Authority: RCW 19.27.031 and 19.27.074. 98-02-055, § 51-46-0815, filed 1/6/98, effective 7/1/98.] Repealed by 02-01-114, filed 12/18/01, effective 7/1/02. Statutory Authority: RCW 19.27.031, 19.27.074.
- 51-46-0900 Vents. [Statutory Authority: RCW 19.27.031 and 19.27.074. 98-02-055, § 51-46-0900, filed 1/6/98, effective 7/1/98.] Repealed by 02-01-114, filed 12/18/01, effective 7/1/02. Statutory Authority: RCW 19.27.031, 19.27.074.
- 51-46-0903 Materials. [Statutory Authority: RCW 19.27.031 and 19.27.074. 98-02-055, § 51-46-0903, filed 1/6/98, effective 7/1/98.] Repealed by 02-01-114, filed 12/18/01, effective 7/1/02. Statutory Authority: RCW 19.27.031, 19.27.074.
- 51-46-1000 Traps and interceptors. [Statutory Authority: RCW 19.27.031 and 19.27.074. 98-02-055, § 51-46-1000, filed 1/6/98, effective 7/1/98.] Repealed by 02-01-114, filed 12/18/01, effective 7/1/02. Statutory Authority: RCW 19.27.031, 19.27.074.
- 51-46-1003 Traps—Described. [Statutory Authority: RCW 19.27.031 and 19.27.074. 98-02-055, § 51-46-1003,

as the building code, as provided in chapters 19.27, 19.27A, and 70.92 RCW, and the state legislature.

The primary objective of the council is to encourage consistency in the building code throughout the state of Washington and to maintain the building code consistent with the state's interest as provided in RCW 19.27.020.

The building code shall be as defined in WAC 51-04-015(6).

The council is also required by RCW 19.27.074 to approve or deny all city and county amendments to the building code that apply to single family or multifamily buildings as defined in RCW 19.27.015.

The purpose of this chapter is to establish policies and procedures for submittal and council review and consideration of proposed statewide and city and county amendments respectively, to the building code.

[Statutory Authority: Chapters 19.27 and 34.05 RCW and 1989 c 348. 90-02-108, § 51-04-010, filed 1/3/90, effective 2/3/90; Order 76-02, § 51-04-010, filed 9/1/76.]

WAC 51-04-015 Definitions. (1) "Supplements and accumulative supplements" mean the publications between editions of the uniform codes and standards which include changes to the current edition of the uniform codes and standards.

(2) "Council" means the Washington state building code council.

(3) "Emergency statewide amendment" means any proposed statewide amendment, the adoption of which is necessary immediately in order to protect life, safety or health of building occupants; preserve the structural integrity of buildings built to the state building code; to correct errors and omissions; or by the direction of the Washington state legislature or federal legislation. Emergency statewide amendments to the state building code must be adopted in accordance with the Administrative Procedure Act, chapter 34.05 RCW.

(4) "Local government amendment" means any amendment to the state building code, as adopted by cities or counties for implementation and enforcement in their respective jurisdictions.

(5) "Local government residential amendment" means any amendment to the state building code, as adopted by cities or counties for implementation and enforcement in their respective jurisdictions, that applies to single and multifamily buildings as defined by RCW 19.27.015.

(6) "State building code" means the Uniform Building Code and Standards; the Uniform Mechanical Code; the Uniform Fire Code and Standards; the Uniform Plumbing Code and Standards; the state regulations for barrier-free facilities, as designated in RCW 19.27.031; the state energy code; and any other codes so designated by the Washington state legislature as adopted and amended by the council.

(7) "Statewide amendment" means any amendment to the building code, initiated through council action or by petition to the council from any agency, city or county, or interested individual or organization, that would have the effect of amending the building code for the entire state of Washington. Statewide amendments to the state building code must be

(2003 Ed.)

adopted in accordance with the Administrative Procedure Act, chapter 34.05 RCW.

(8) "State building code update cycle" means that period during which the uniform code and standards referenced in chapter 19.27 RCW are updated and amended by the council in accordance with the Administrative Procedure Act, chapter 34.05 RCW hereinafter referred to as the "adoption period" and those additional periods when code changes are received for review as proposed amendments to the uniform codes, hereinafter referred to as "submission periods."

(9) "Uniform codes" means the Uniform Building, Mechanical, Plumbing, and Fire Codes as published by the International Conference of Building Officials, International Association of Plumbing and Mechanical Officials, and Western Fire Chiefs respectively.

[Statutory Authority: RCW 19.27.035 and 19.27.074. 98-24-077, § 51-04-015, filed 12/1/98, effective 7/1/99. Statutory Authority: RCW 19.27.074. 98-02-048, § 51-04-015, filed 1/5/98, effective 7/1/98. Statutory Authority: RCW 19.27.035 and chapter 34.05 RCW. 94-05-058, § 51-04-015, filed 2/10/94, effective 3/13/94. Statutory Authority: Chapters 19.27 and 34.05 RCW and 1989 c 348. 90-02-108, § 51-04-015, filed 1/3/90, effective 2/3/90.]

WAC 51-04-018 Petition for preliminary review. An agency, city or county, or other interested individual or organization wishing to submit statewide or local government residential amendments to the building code for council consideration, may file with the council a petition for preliminary review of the statewide or local government residential amendment, in order to solicit comments from council members and interested parties, prior to council action.

The council may refer a petition for preliminary review to one of the council standing committees for review and comment.

[Statutory Authority: RCW 19.27.035 and chapter 34.05 RCW. 94-05-058, § 51-04-018, filed 2/10/94, effective 3/13/94. Statutory Authority: Chapters 19.27 and 34.05 RCW and 1989 c 348. 90-02-108, § 51-04-018, filed 1/3/90, effective 2/3/90.]

WAC 51-04-020 Policies for the consideration of proposed statewide amendments. Statewide and emergency statewide amendments to the state building code should be based on one of the following criteria:

(1) The amendment is needed to address a critical life/safety need.

(2) The amendment is needed to address a specific state policy or statute.

(3) The amendment is needed for consistency with state or federal regulations.

(4) The amendment is needed to address a unique character of the state.

(5) The amendment corrects errors and omissions.

Statewide and emergency statewide amendments to the state building code shall conform to the purposes, objectives, and standards prescribed in RCW 19.27.020.

The council will accept and consider petitions for emergency statewide amendments to the building code at any time, in accordance with RCW 19.27.074 and chapter 34.05 RCW.

The council will accept and consider all other petitions for statewide amendments in conjunction with the state build-

ing code update cycle, in accordance with RCW 19.27.074 and chapter 34.05 RCW, and WAC 51-04-015 and 51-04-020 as follows:

In every year excluding the year with the adoption period, the state building code council shall identify a submission period of at least thirty days when revisions to the uniform codes and the state building code which addresses portions of the state building code other than uniform codes may be submitted. The state building code council shall review all submissions and accept for future rule making those revisions favorably reviewed. Revisions accepted shall be submitted to the International Conference of Building Officials, the International Association of Plumbing and Mechanical Officials and the International Fire Code Institute, respectively, as proposed revisions to the uniform codes (unless recently considered as amendments) and held for further review during the adoption period.

The adoption period commences upon availability of the publication of the new edition of the uniform codes by the International Conference of Building Officials, and concludes with formal adoption of the revised building code by the council and final review by the state legislature. For the purposes of this section, the publication of supplements shall not be considered a new edition. At the beginning of the adoption period, the state building code council shall identify a limited submission period of at least thirty days. During this period, the council will receive revisions proposed to:

The uniform codes provided that the proposed revisions shall be limited to revisions which address changes in the uniform codes since the previous edition.

The state building code which addresses existing statewide amendments to the uniform codes.

The state building code which addresses portions of the state building code other than the uniform codes.

In addition, the state building code council shall review for adoption those proposed revisions to the uniform code accepted after preliminary review in those submission periods since the last adoption period. The state building code council shall consider the action of the International Conference of Building Officials, the International Association of Plumbing and Mechanical Officials and the International Fire Code Institute, respectively, in their consideration of these proposals.

Within sixty days of the receipt of the new edition of the uniform codes the council shall enter rule making to update the building code.

[Statutory Authority: RCW 19.27.035 and chapter 34.05 RCW. 94-05-058, § 51-04-020, filed 2/10/94, effective 3/13/94. Statutory Authority: Chapters 19.27 and 34.05 RCW and 1989 c 348. 90-02-108, § 51-04-020, filed 1/3/90, effective 2/3/90; Order 76-02, § 51-04-020, filed 9/1/76.]

WAC 51-04-025 Procedure for submittal or proposed statewide amendments. All proposed statewide amendments shall be submitted in writing to the council, on the form provided by the council.

Petitions for statewide amendments to the building code shall be submitted to the council during the submission period and the adoption period in accordance with WAC 51-04-020.

Petitions for emergency statewide amendments to the building code may be submitted at any time, in accordance with RCW 19.27.074 and chapter 34.05 RCW, and WAC 51-04-015 and 51-04-020.

The council may refer a proposed statewide amendment to one of the council standing committees for review and comment prior to council action in accordance with chapter 34.05 RCW.

The council shall deal with all proposed statewide amendments within the time frames required by chapter 19.27 RCW, RCW 34.05.330, and all other deadlines established by statute.

[Statutory Authority: RCW 19.27.035 and chapter 34.05 RCW. 94-05-058, § 51-04-025, filed 2/10/94, effective 3/13/94. Statutory Authority: Chapters 19.27 and 34.05 RCW and 1989 c 348. 90-02-108, § 51-04-025, filed 1/3/90, effective 2/3/90.]

WAC 51-04-030 Policies for consideration of proposed local government residential amendments. All amendments to the building code, as adopted by cities and counties for implementation and enforcement in their respective jurisdictions, that apply to single and multifamily buildings as defined by RCW 19.27.015, shall be submitted to the council for approval.

The council shall consider and approve or deny all proposed local government residential amendments to the building code within ninety days of receipt of a proposal, unless alternative scheduling is agreed to by the council and the proposing entity.

All local government residential amendments to the building code that require council approval shall be submitted in writing to the council, after the city or county legislative body has adopted the amendment and prior to implementation and enforcement of the amendment by the local jurisdiction.

It is the policy of the council to encourage joint proposals for local government residential amendments from more than one jurisdiction. Local government residential amendments submitted to the council for approval should be based on:

- (1) Climatic conditions that are unique to the jurisdiction.
- (2) Geologic or seismic conditions that are unique to the jurisdiction.
- (3) Environmental impacts such as noise, dust, etc., that are unique to the jurisdiction.
- (4) Life, health, or safety conditions that are unique to the local jurisdiction.
- (5) Other special conditions that are unique to the jurisdiction.

EXCEPTIONS: Appendices or portions thereof that have the effect of amending the uniform codes, that do not conflict with the building code for single and multifamily residential buildings as defined by RCW 19.27.015, may be adopted by local jurisdictions without council review or approval. Local government residential amendments to:

- (1) Chapter 1, 17, or 34 of the Uniform Building Code;
- (2) Chapter 1 of the Uniform Mechanical Code;
- (3) Article 1 of the Uniform Fire Code;
- (4) Chapter 1 of the Uniform Plumbing Code;
- (5) Chapter 1 or 11 of the State Energy Code; or
- (6) Chapter 1 of the Ventilation and Indoor Air Quality Code need not be submitted to the Council for review and

approval provided that such amendments do not diminish the construction requirements of those chapters. Those portions of the supplement or accumulative supplements that affect single and multifamily residential buildings as defined by RCW 19.27.015 that are not adopted by the council shall be submitted to the council for consideration as local government residential amendments to the building code.
Local government residential amendments shall conform to the limitations provided in RCW 19.27.040.

[Statutory Authority: RCW 19.27.035 and 19.27.074. 98-24-077, § 51-04-030, filed 12/1/98, effective 7/1/99. Statutory Authority: Chapter 19.27 RCW. 95-01-127, § 51-04-030, filed 12/21/94, effective 6/30/95. Statutory Authority: Chapters 19.27 and 34.05 RCW and 1989 c 348. 90-02-108, § 51-04-030, filed 1/3/90, effective 2/3/90.]

WAC 51-04-035 Procedure for submittal of proposed local government residential amendments. All proposed local government residential amendments to the state building code shall be submitted in writing to the council, on a form provided by the council, along with a statement of need for the proposed amendment.

The council shall accept and consider all applications for review of local government residential amendments submitted to the council in a proper manner.

The council may refer a proposed local government residential amendment to one of the council standing committees for review and comment prior to council action in accordance with RCW 19.27.074.

[Statutory Authority: Chapters 19.27 and 34.05 RCW and 1989 c 348. 90-02-108, § 51-04-035, filed 1/3/90, effective 2/3/90.]

WAC 51-04-037 Preapproved local government residential amendments. Any local government residential amendment, that the council determines to be appropriate for adoption by other local governments, may be designated as a preapproved local government residential amendment.

A preapproved local government residential amendment may be adopted by any local government upon notification of the council.

[Statutory Authority: Chapters 19.27 and 34.05 RCW and 1989 c 348. 90-02-108, § 51-04-037, filed 1/3/90, effective 2/3/90.]

WAC 51-04-040 Reconsideration. Any party proposing a statewide or local government amendment to the building code may, upon denial of the amendment by the council, file a petition for reconsideration.

Within ten days of a building code council vote to deny a statewide or local government amendment, any party may file a petition for reconsideration, stating the specific justification for rule adoption or local amendment. The petition shall be filed with the State Building Code Council, P.O. Box 48300, Olympia, Washington 98504.

The council is deemed to have denied the petition for reconsideration if, within sixty days from the date the petition is filed, the council does not either:

- (1) Dispose of the petition; or
- (2) Serve the parties with a written notice specifying the date by which it will act on the petition.

Unless the petition is deemed denied, the petition shall be disposed of by the council with recommendations from the same committee or committees that considered the proposed rule or local amendment. The disposition shall be in the form

of a written notice denying the petition, granting the petition and refiling the rule-making order or approving the local amendment, or granting the petition and setting the matter for further hearings.

[Statutory Authority: RCW 19.27.035 and chapters 19.27 and 34.05 RCW. 02-01-113, § 51-04-040, filed 12/18/01, effective 7/1/02. Statutory Authority: Chapters 19.27 and 34.05 RCW and 1989 c 348. 90-02-108, § 51-04-040, filed 1/3/90, effective 2/3/90.]

WAC 51-04-050 Ex parte communications. All written communications received by council members during council rule-making proceedings, shall be forwarded to staff for inclusion in the public record.

[Statutory Authority: Chapters 19.27 and 34.05 RCW and 1989 c 348. 90-02-108, § 51-04-050, filed 1/3/90, effective 2/3/90.]

WAC 51-04-060 Opinions. RCW 19.27.031 grants the council authority to render opinions relating to the building code at the request of a local building official.

For the purposes of this section, the term "building official" means the local or state official, or their designee, responsible for implementation and enforcement of the specific code provision on which the opinion is requested.

Council building code related opinions shall be limited to the state regulations for barrier-free facilities, the state energy code, the state ventilation and indoor air quality code, and council amendments to the uniform codes.

Council related opinions may be developed and approved by a standing committee of the council.

Opinions approved by a standing committee may be reviewed and modified by the council.

[Statutory Authority: RCW 19.27.035 and 19.27.074. 98-24-077, § 51-04-060, filed 12/1/98, effective 7/1/99. Statutory Authority: RCW 19.27.035 and chapter 34.05 RCW. 94-05-058, § 51-04-060, filed 2/10/94, effective 3/13/94. Statutory Authority: Chapters 19.27 and 34.05 RCW and 1989 c 348. 90-02-108, § 51-04-060, filed 1/3/90, effective 2/3/90.]

WAC 51-04-070 Council mailing address. All requests for information, documentation, etc., should be submitted to:

Washington State Building Code Council
906 Columbia St SW
Post Office Box 48300
Olympia, Washington 98504-8300
(360) 586-0486

[Statutory Authority: RCW 19.27.074. 98-02-048, § 51-04-070, filed 1/5/98, effective 7/1/98. Statutory Authority: Chapters 19.27 and 34.05 RCW and 1989 c 348. 90-02-108, § 51-04-070, filed 1/3/90, effective 2/3/90.]

Chapter 51-06 WAC PUBLIC RECORDS

WAC

51-06-010
51-06-020
51-06-070
51-06-120

Purpose of chapter.
Public records available.
Copying.
Address for communications.

DISPOSITION OF SECTIONS FORMERLY
CODIFIED IN THIS CHAPTER

51-06-030	Definitions. [Order 76-02, § 51-06-030, filed 9/1/76.] Repealed by 90-02-108, filed 1/3/90, effective 2/3/90. Statutory Authority: Chapters 19.27 and 34.05 RCW and 1989 c 348.
51-06-040	Public records officer. [Order 76-02, § 51-06-040, filed 9/1/76.] Repealed by 90-02-108, filed 1/3/90, effective 2/3/90. Statutory Authority: Chapters 19.27 and 34.05 RCW and 1989 c 348.
51-06-050	Office hours. [Order 76-02, § 51-06-050, filed 9/1/76.] Repealed by 90-02-108, filed 1/3/90, effective 2/3/90. Statutory Authority: Chapters 19.27 and 34.05 RCW and 1989 c 348.
51-06-060	Requests for public records. [Order 76-02, § 51-06-060, filed 9/1/76.] Repealed by 90-02-108, filed 1/3/90, effective 2/3/90. Statutory Authority: Chapters 19.27 and 34.05 RCW and 1989 c 348.
51-06-080	Exemptions. [Order 76-02, § 51-06-080, filed 9/1/76.] Repealed by 90-02-108, filed 1/3/90, effective 2/3/90. Statutory Authority: Chapters 19.27 and 34.05 RCW and 1989 c 348.
51-06-090	Review of denials of public records requests. [Order 76-02, § 51-06-090, filed 9/1/76.] Repealed by 90-02-108, filed 1/3/90, effective 2/3/90. Statutory Authority: Chapters 19.27 and 34.05 RCW and 1989 c 348.
51-06-100	Protection of public records. [Order 76-02, § 51-06-100, filed 9/1/76.] Repealed by 90-02-108, filed 1/3/90, effective 2/3/90. Statutory Authority: Chapters 19.27 and 34.05 RCW and 1989 c 348.
51-06-110	Records index. [Order 76-02, § 51-06-110, filed 9/1/76.] Repealed by 90-02-108, filed 1/3/90, effective 2/3/90. Statutory Authority: Chapters 19.27 and 34.05 RCW and 1989 c 348.

WAC 51-06-010 Purpose of chapter. The purpose of this chapter shall be to ensure compliance by the state building code council (hereinafter referred to as the "council"), including its members and staff, with the provisions of chapter 42.17 RCW (Initiative 276), and in particular with RCW 42.17.250 - 42.17.320 dealing with public records.

[Statutory Authority: Chapters 19.27 and 34.05 RCW and 1989 c 348. 90-02-108, § 51-06-010, filed 1/3/90, effective 2/3/90; Order 76-02, § 51-06-010, filed 9/1/76.]

WAC 51-06-020 Public records available. All public records of the council as defined in WAC 51-06-030 are available for public inspection and copying at the Department of Community Development, 906 Columbia St. SW, Olympia, Washington 98504, pursuant to these rules, except as otherwise provided by RCW 42.17.310.

[Statutory Authority: RCW 19.27.074. 98-02-049, § 51-06-020, filed 1/5/98, effective 7/1/98. Statutory Authority: Chapters 19.27 and 34.05 RCW and 1989 c 348. 90-02-108, § 51-06-020, filed 1/3/90, effective 2/3/90; Order 76-02, § 51-06-020, filed 9/1/76.]

WAC 51-06-070 Copying. The department of community development may charge a fee of twenty-five cents per page for providing copies of public records and for use of the office's copy equipment.

[Statutory Authority: Chapters 19.27 and 34.05 RCW and 1989 c 348. 90-02-108, § 51-06-070, filed 1/3/90, effective 2/3/90; Order 76-02, § 51-06-070, filed 9/1/76.]

WAC 51-06-120 Address for communications. All requests for information, documentation, etc., should be submitted to the:

Washington State Building Code Council
906 Columbia St SW

Post Office Box 48300
Olympia, Washington 98504-8300
(360) 586-0486

[Statutory Authority: RCW 19.27.074. 98-02-049, § 51-06-120, filed 1/5/98, effective 7/1/98. Statutory Authority: Chapters 19.27 and 34.05 RCW and 1989 c 348. 90-02-108, § 51-06-120, filed 1/3/90, effective 2/3/90; Order 76-02, § 51-06-120, filed 9/1/76.]

Chapter 51-08 WAC
UNIFORM PROCEDURAL RULES

WAC

51-08-010 Uniform procedural rules.

WAC 51-08-010 Uniform procedural rules. The state building code council, hereinafter referred to as the council, adopts as its own rules of practice all those uniform procedural rules promulgated by the code reviser now codified in the Washington Administrative Code, as WAC 1-08-005 through 1-08-590, as now or hereinafter amended, subject to any additional rules the council may add from time to time. The council reserves the right to make whatever determination is fair and equitable should any question not covered by its rules come before the council, said determination to be in accordance with the spirit and intent of the law.

[Statutory Authority: Chapters 19.27 and 34.05 RCW and 1989 c 348. 90-02-108, § 51-08-010, filed 1/3/90, effective 2/3/90; Order 76-02, § 51-08-010, filed 9/1/76.]

Chapter 51-11 WAC
WASHINGTON STATE ENERGY CODE

WAC

51-11-0100	Chapter 1—Administration and enforcement.
51-11-0101	Section 101. Scope and general requirements.
51-11-0102	Materials and equipment.
51-11-0103	Alternate materials—Method of construction, design or insulating systems.
51-11-0104	Plans and specifications.
51-11-0105	Inspections and enforcement.
51-11-0106	Violations.
51-11-0107	Liability.
51-11-0108	Conflicts with other codes.
51-11-0109	Severability.
51-11-0200	Chapter 2—Definitions.
51-11-0201	Scope.
51-11-0300	Chapter 3—Design conditions.
51-11-0301	Design criteria.
51-11-0302	Thermal design parameters.
51-11-0303	Mechanical ventilation.
51-11-0400	Chapter 4—Building design by systems analysis.
51-11-0401	Scope.
51-11-0402	Systems analysis.
51-11-0500	Chapter 5—Building design by component performance approach.
51-11-0501	Scope.
51-11-0502	Building envelope requirements.
51-11-0503	Building mechanical systems.
51-11-0504	Service water heating.
51-11-0505	Lighting.
51-11-0525	Equation 1—Group R Occupancy.
51-11-0526	Equation 2—All occupancies.
51-11-0527	Equation 3—Group R Occupancy.
51-11-0528	Equation 4—Reserved.
51-11-0529	Equation 5—Reserved.
51-11-0530	Table 5-1.
51-11-0531	Table 5-2—Reserved.
51-11-0532	Table 5-3—Reserved.
51-11-0533	Table 5-4—Reserved.
51-11-0534	Table 5-5—Reserved.
51-11-0535	Table 5-6—Reserved.

- 51-11-0536 Table 5-7—Reserved.
- 51-11-0537 Table 5-8—Reserved.
- 51-11-0538 Table 5-9—Reserved.
- 51-11-0539 Table 5-10—Reserved.
- 51-11-0540 Table 5-11.
- 51-11-0541 Table 5-12.
- 51-11-0542 Table 5-13—Reserved.
- 51-11-0600 Chapter 6 building design by prescriptive requirements approach.
- 51-11-0601 Scope.
- 51-11-0602 Building envelope requirements for Group R Occupancy.
- 51-11-0603 Building mechanical systems for Group R Occupancy.
- 51-11-0604 Reserved.
- 51-11-0605 Lighting.
- 51-11-0625 Table 6-1.
- 51-11-0626 Table 6-2—Reserved.
- 51-11-0627 Table 6-3—Reserved.
- 51-11-0628 Table 6-4—Reserved.
- 51-11-0629 Table 6-5—Reserved.
- 51-11-0630 Table 6-6—Reserved.
- 51-11-0631 Table 6-7—Reserved.
- 51-11-0700 Chapter 7—Standards.
- 51-11-0701 Scope.
- 51-11-0800 Section 0800—Suggested software for chapter 4 systems analysis approach for Group R Occupancy.
- 51-11-0900 Section 0900—Prescriptive heating system sizing.
- 51-11-1000 Chapter 10.
- 51-11-1001 Section 1001 General.
- 51-11-1002 Section 1002: Below grade walls and slabs.
- 51-11-1003 Section 1003: On-grade slab floors.
- 51-11-1004 Section 1004: Floors over unconditioned space.
- 51-11-1005 Section 1005: Above-grade walls.
- 51-11-1006 Section 1006 Default U-factors for glazing and doors.
- 51-11-1007 Section 1007 Ceilings.
- 51-11-1008 Section 1008 Air infiltration.
- 51-11-1009 Section 1009 Mass.

**CHAPTER 11
ADMINISTRATION AND ENFORCEMENT**

- 51-11-1100 Title.
- 51-11-1110 Purpose and intent.
- 51-11-1120 Scope.
- 51-11-1130 Application to existing buildings.
- 51-11-1131 Additions to existing buildings.
- 51-11-1132 Alterations and repairs.
- 51-11-1133 Change of occupancy or use.
- 51-11-1134 Historic buildings.
- 51-11-1140 Enforcement.
- 51-11-1141 Plans and specifications.
- 51-11-1142 Materials and equipment.
- 51-11-1143 Inspections.
- 51-11-1144 Violations.
- 51-11-1150 Conflicts with other codes.
- 51-11-1160 Severability and liability.

**CHAPTER 12
DEFINITIONS**

Note: For nonresidential definitions, see chapter 2.

**CHAPTER 13
BUILDING ENVELOPE**

- 51-11-1301 Scope.
- 51-11-1302 Space heat type.
- 51-11-1303 Climate zones.
- 51-11-1310 General requirements.
- 51-11-1311 Insulation.
- 51-11-1312 Glazing and doors.
- 51-11-1313 Moisture control.
- 51-11-1314 Air leakage.
- 51-11-1320 Prescriptive building envelope option.
- 51-11-1321 General.
- 51-11-1322 Opaque envelope.
- 51-11-1323 Glazing.
- 51-11-1330 Component performance building envelope option.
- 51-11-1331 General.
- 51-11-1332 Component U-factors.
- 51-11-1333 UA calculations.
- 51-11-1334 Solar heat gain coefficient rate calculations.

**CHAPTER 14
BUILDING MECHANICAL SYSTEMS**

- 51-11-1401 Scope.

- 51-11-1402 Mechanical ventilation.
- 51-11-1410 General requirements.
- 51-11-1411 HVAC equipment performance requirements.
- 51-11-1412 Controls.
- 51-11-1413 Economizers.
- 51-11-1414 Ducting systems.
- 51-11-1415 Piping systems.
- 51-11-1416 Completion requirements.
- 51-11-1420 Simple systems (packaged unitary equipment).
- 51-11-1421 System type.
- 51-11-1422 Controls.
- 51-11-1423 Economizers.
- 51-11-1424 Separate air distribution systems.
- 51-11-1430 Complex systems.
- 51-11-1431 System type.
- 51-11-1432 Controls.
- 51-11-1433 Economizers.
- 51-11-1434 Separate air distribution systems.
- 51-11-1435 Simultaneous heating and cooling.
- 51-11-1436 Heat recovery.
- 51-11-1437 Electric motor efficiency.
- 51-11-1438 Variable flow systems.
- 51-11-1439 Exhaust hoods.
- 51-11-1440 Service water heating.
- 51-11-1441 Water heater installation.
- 51-11-1442 Shut-off controls.
- 51-11-1443 Pipe insulation.
- 51-11-1450 Heated pools.
- 51-11-1451 General.
- 51-11-1452 Pool water heaters.
- 51-11-1453 Controls.
- 51-11-1454 Pool covers.

**CHAPTER 15
LIGHTING AND MOTORS**

- 51-11-1501 Scope.
- 51-11-1510 General requirements.
- 51-11-1511 Electric motors.
- 51-11-1512 Exempt lighting.
- 51-11-1513 Lighting controls.
- 51-11-1520 Prescriptive lighting option.
- 51-11-1521 Prescriptive interior lighting requirements.
- 51-11-1522 Prescriptive exterior lighting requirements.
- 51-11-1530 Lighting power allowance option.
- 51-11-1531 Interior lighting power allowance.
- 51-11-1532 Exterior lighting power allowance.

**CHAPTER 16
RESERVED**

**CHAPTER 17
STANDARDS**

Note: For nonresidential standards, see chapter 7.

**CHAPTER 18
RESERVED**

**CHAPTER 19
RESERVED**

**CHAPTER 20
DEFAULT HEAT-LOSS COEFFICIENTS**

Note: For nonresidential defaults, see chapter 10.

**REFERENCE STANDARD NONRESIDENTIAL
BUILDING DESIGN BY SYSTEMS ANALYSIS**

- 51-11-99901 Section 1—Scope.
- 51-11-99902 Section 2—General principles and requirements.
- 51-11-99903 Section 3—Specific modeling assumptions.
- 51-11-99904 Section 4—Suggested software for systems analysis approach.

**DISPOSITION OF SECTIONS FORMERLY
CODIFIED IN THIS CHAPTER**

- 51-11-0606 Reserved. [Statutory Authority: RCW 19.27A.025. 93-21-052, § 51-11-0606, filed 10/18/93, effective 4/1/94. Statutory Authority: RCW 19.27A.020 and 1990 c 2. 91-01-112, § 51-11-0606, filed 12/19/90, effective 7/1/91.] Repealed by 98-03-003, filed 1/8/98, effective 7/1/98. Statutory Authority: RCW 19.27A.025 and 19.27A.045.

- 51-11-0607 Reserved. [Statutory Authority: RCW 19.27A.025. 93-21-052, § 51-11-0607, filed 10/18/93, effective 4/1/94. Statutory Authority: RCW 19.27A.020 and 1990 c 2. 91-01-112, § 51-11-0607, filed 12/19/90, effective 7/1/91.] Repealed by 98-03-003, filed 1/8/98, effective 7/1/98. Statutory Authority: RCW 19.27A.025 and 19.27A.045.
- 51-11-0608 Reserved. [Statutory Authority: RCW 19.27A.025. 93-21-052, § 51-11-0608, filed 10/18/93, effective 4/1/94. Statutory Authority: Chapter 19.27A RCW. 92-01-140, § 51-11-0608, filed 12/19/91, effective 7/1/92. Statutory Authority: RCW 19.27A.020 and 1990 c 2. 91-01-112, § 51-11-0608, filed 12/19/90, effective 7/1/91.] Repealed by 98-03-003, filed 1/8/98, effective 7/1/98. Statutory Authority: RCW 19.27A.025 and 19.27A.045.
- 51-11-1010 Section 1009 Mass. [Statutory Authority: RCW 19.27A.020 and 1990 c 2. 91-01-112, § 51-11-1010, filed 12/19/90, effective 7/1/91.] Repealed by 98-03-003, filed 1/8/98, effective 7/1/98. Statutory Authority: RCW 19.27A.025 and 19.27A.045.
- 51-11-1201 Scope. [Statutory Authority: RCW 19.27A.025. 93-21-052, § 51-11-1201, filed 10/18/93, effective 4/1/94.] Repealed by 01-03-010, filed 1/5/01, effective 7/1/01. Statutory Authority: RCW 19.27A.025, 19.27A.045.
- 51-11-1210 Application of terms. [Statutory Authority: RCW 19.27A.025 and 19.27A.045. 98-03-003, § 51-11-1210, filed 1/8/98, effective 7/1/98. Statutory Authority: RCW 19.27.074, 19.27A.020 and 19.27A.025. 97-03-017, § 51-11-1210, filed 1/7/97, effective 7/1/97. Statutory Authority: RCW 19.27A.025. 93-21-052, § 51-11-1210, filed 10/18/93, effective 4/1/94.] Repealed by 01-03-010, filed 1/5/01, effective 7/1/01. Statutory Authority: RCW 19.27A.025, 19.27A.045.
- 51-11-1701 Scope. [Statutory Authority: RCW 19.27A.025 and 19.27A.045. 98-03-003, § 51-11-1701, filed 1/8/98, effective 7/1/98. Statutory Authority: RCW 19.27A.025. 93-21-052, § 51-11-1701, filed 10/18/93, effective 4/1/94.] Repealed by 01-03-010, filed 1/5/01, effective 7/1/01. Statutory Authority: RCW 19.27A.025, 19.27A.045.
- 51-11-2000 Default heat-loss coefficients. [Statutory Authority: RCW 19.27A.025. 93-21-052, § 51-11-2000, filed 10/18/93, effective 4/1/94.] Repealed by 01-03-010, filed 1/5/01, effective 7/1/01. Statutory Authority: RCW 19.27A.025, 19.27A.045.
- 51-11-2001 General. [Statutory Authority: RCW 19.27A.025. 93-21-052, § 51-11-2001, filed 10/18/93, effective 4/1/94.] Repealed by 01-03-010, filed 1/5/01, effective 7/1/01. Statutory Authority: RCW 19.27A.025, 19.27A.045.
- 51-11-2002 Below grade walls and slabs. [Statutory Authority: RCW 19.27A.025. 93-21-052, § 51-11-2002, filed 10/18/93, effective 4/1/94.] Repealed by 01-03-010, filed 1/5/01, effective 7/1/01. Statutory Authority: RCW 19.27A.025, 19.27A.045.
- 51-11-2003 On-grade slab floors. [Statutory Authority: RCW 19.27A.025. 93-21-052, § 51-11-2003, filed 10/18/93, effective 4/1/94.] Repealed by 01-03-010, filed 1/5/01, effective 7/1/01. Statutory Authority: RCW 19.27A.025, 19.27A.045.
- 51-11-2004 Floors over unconditioned space. [Statutory Authority: RCW 19.27A.025. 93-21-052, § 51-11-2004, filed 10/18/93, effective 4/1/94.] Repealed by 01-03-010, filed 1/5/01, effective 7/1/01. Statutory Authority: RCW 19.27A.025, 19.27A.045.
- 51-11-2005 Above grade walls. [Statutory Authority: RCW 19.27A.025 and 19.27A.045. 98-03-003, § 51-11-2005, filed 1/8/98, effective 7/1/98. Statutory Authority: RCW 19.27A.025. 93-21-052, § 51-11-2005, filed 10/18/93, effective 4/1/94.] Repealed by 01-03-010, filed 1/5/01, effective 7/1/01. Statutory Authority: RCW 19.27A.025, 19.27A.045.
- 51-11-2006 Default U-factors for glazing and doors. [Statutory Authority: RCW 19.27A.025 and 19.27A.045. 98-03-003, § 51-11-2006, filed 1/8/98, effective 7/1/98. Statutory Authority: RCW 19.27A.025. 93-21-052, § 51-11-2006, filed 10/18/93, effective 4/1/94.] Repealed by 01-03-010, filed 1/5/01, effective 7/1/01. Statutory Authority: RCW 19.27A.025, 19.27A.045.
- 51-11-2007 Ceilings. [Statutory Authority: RCW 19.27A.025 and 19.27A.045. 98-03-003, § 51-11-2007, filed 1/8/98, effective 7/1/98. Statutory Authority: RCW 19.27A.025. 93-21-052, § 51-11-2007, filed 10/18/93, effective 4/1/94.] Repealed by 01-03-010, filed 1/5/01, effective 7/1/01. Statutory Authority: RCW 19.27A.025. 93-21-052, § 51-11-2007, filed 10/18/93, effective 4/1/94.] Repealed by 01-03-010, filed 1/5/01, effective 7/1/01. Statutory Authority: RCW 19.27A.025, 19.27A.045.
- 51-11-2008 Reserved. [Statutory Authority: RCW 19.27A.025. 93-21-052, § 51-11-2008, filed 10/18/93, effective 4/1/94.] Repealed by 01-03-010, filed 1/5/01, effective 7/1/01. Statutory Authority: RCW 19.27A.025, 19.27A.045.
- 51-11-2009 Mass. [Statutory Authority: RCW 19.27A.025. 93-21-052, § 51-11-2009, filed 10/18/93, effective 4/1/94.] Repealed by 01-03-010, filed 1/5/01, effective 7/1/01. Statutory Authority: RCW 19.27A.025, 19.27A.045.

WAC 51-11-0100 Chapter 1—Administration and enforcement.

[Statutory Authority: RCW 19.27A.020 and 1990 c 2. 91-01-112, § 51-11-0100, filed 12/19/90, effective 7/1/91.]

WAC 51-11-0101 Section 101. Scope and general requirements.

101.1 Title: Chapters 1 through 10 of this Code shall be known as the "Washington State Residential Energy Code" and may be cited as such; and will be referred to herein as "this Code."

101.2 Purpose and Intent: The purpose of this Code is to provide minimum standards for new or altered buildings and structures or portions thereof to achieve efficient use and conservation of energy.

The purpose of this Code is not to create or otherwise establish or designate any particular class or group of persons who will or should be especially protected or benefitted by the terms of this Code.

It is intended that these provisions provide flexibility to permit the use of innovative approaches and techniques to achieve efficient use and conservation of energy. These provisions are structured to permit compliance with the intent of this Code by any one of the following three paths of design:

1. A systems analysis approach for the entire building and its energy-using sub-systems which may utilize renewable energy sources, Chapter 4.
2. A component performance approach for various building elements and mechanical systems and components, Chapter 5.
3. A prescriptive requirements approach, Chapter 6.

Compliance with any one of these approaches meets the intent of this Code. This Code is not intended to abridge any safety or health requirements required under any other applicable codes or ordinances.

The provisions of this Code do not consider the efficiency of various energy forms as they are delivered to the building envelope. A determination of delivered energy efficiencies in conjunction with this Code will provide the most efficient use of available energy in new building construction.

101.3 Scope: This Code sets forth minimum requirements for the design of new buildings and structures that provide facilities or shelter for residential occupancies by regulating their exterior envelopes and the selection of their

HVAC, service water heating systems and equipment for efficient use and conservation of energy.

Buildings shall be designed to comply with the requirements of either Chapter 4, 5, or 6 of this Code.

101.3.1 Exempt Buildings: Buildings and structures or portions thereof meeting any of the following criteria shall be exempt from the building envelope requirements of sections 502 and 602, but shall comply with all other requirements for building mechanical systems, and service water heating.

101.3.1.1: Buildings and structures or portions thereof whose peak design rate of energy usage is less than three and four tenths (3.4) Btu/h per square foot or one point zero (1.0) watt per square foot of floor area for space conditioning requirements.

101.3.1.2: Buildings and structures or portions thereof which are neither heated according to the definition of heated space in Chapter 2, nor cooled by a nonrenewable energy source, provided that the nonrenewable energy use for space conditioning complies with requirements of section 101.3.1.1.

101.3.1.3: Greenhouses isolated from any conditioned space and not intended for occupancy.

101.3.1.4: The provisions of this code do not apply to the construction, alteration, or repair of temporary worker housing except as provided by rule adopted under chapter 70.114A RCW or chapter 37, Laws of 1998 (SB 6168). "Temporary worker housing" means a place, area, or piece of land where sleeping places or housing sites are provided by an employer for his or her employees or by another person, including a temporary worker housing operator, who is providing such accommodations for employees, for temporary, seasonal occupancy, and includes "labor camps" under RCW 70.54.110.

101.3.2 Application to Existing Buildings: Additions, historic buildings, changes of occupancy or use, and alterations or repairs shall comply with the requirements in the subsections below.

EXCEPTION: The building official may approve designs of alterations or repairs which do not fully conform with all of the requirements of this Code where in the opinion of the building official full compliance is physically impossible and/or economically impractical and:

1. The alteration or repair improves the energy efficiency of the building; or
2. The alteration or repair is energy efficient and is necessary for the health, safety, and welfare of the general public.

In no case, shall building envelope requirements or mechanical system requirements be less than those requirements in effect at the time of the initial construction of the building.

101.3.2.1 Additions to Existing Buildings: Additions to existing buildings or structures may be made to such buildings or structures without making the entire building or structure comply, provided that the new additions shall conform to the provisions of this Code.

EXCEPTION: New additions which do not fully comply with the requirements of this Code and which have a floor area which is less than seven hundred fifty square feet shall

be approved provided that improvements are made to the existing occupancy to compensate for any deficiencies in the new addition. Compliance shall be demonstrated by either systems analysis or component performance calculations. The nonconforming addition and upgraded, existing occupancy shall have an energy budget or Target UA which is less than or equal to the unimproved existing building (minus any elements which are no longer part of the building envelope once the addition is added), with the addition designed to comply with this Code.

101.3.2.2 Historic Buildings: The building official may modify the specific requirements of this Code for historic buildings and require in lieu thereof alternate requirements which will result in a reasonable degree of energy efficiency. This modification may be allowed for those buildings which have been specifically designated as historically significant by the state or local governing body, or listed in The National Register of Historic Places or which have been determined to be eligible for listing.

101.3.2.3 Change of Occupancy or Use:

Any Other than Group R Occupancy which is converted to Group R Occupancy shall be brought into full compliance with this Code.

101.3.2.4 Alterations and Repairs: All alterations and repairs to buildings or portions thereof originally constructed subject to the requirements of this Code shall conform to the provisions of this Code without exception. For all other existing buildings, initial tenant alterations shall comply with the new construction requirements of this Code. Other alterations and repairs may be made to existing buildings and moved buildings without making the entire building comply with all of the requirements of this Code for new buildings, provided the following requirements are met:

101.3.2.5 Building Envelope: The result of the alterations or repairs both:

1. Improves the energy efficiency of the building, and

2. Complies with the overall average thermal transmittance values of the elements of the exterior building envelope in Table 5-1 of Chapter 5 or the nominal R-values and glazing requirements of the reference case in Tables 6-1 to 6-6.

EXCEPTIONS:

1. Untested storm windows may be installed over existing glazing for an assumed U-factor of 0.90, however, where glass and sash are being replaced in Group R Occupancy, glazing shall comply with the appropriate reference case in Table 6-1 through Table 6-6.

2. Where the structural elements of the altered portions of roof/ceiling, wall or floor are not being replaced, these elements shall be deemed to comply with this Code if all existing framing cavities which are exposed during construction are filled to the full depth with batt insulation or insulation having an equivalent nominal R-value while, for roof/ceilings, maintaining the required space for ventilation. Existing walls and floors without framing cavities need not be insulated. Existing roofs shall be insulated to the requirements of this Code if

a. The roof is uninsulated or insulation is removed to the level of the sheathing, or

b. All insulation in the roof/ceiling was previously installed exterior to the sheathing or nonexistent.

101.3.2.6 Building Mechanical Systems: Those parts of systems which are altered or replaced shall comply with section 503 of this Code.

101.3.2.7 Service Water Heating: Those parts of systems which are altered or replaced shall comply with section 504.

101.3.2.8 Lighting: Alterations shall comply with section 1132.3.

EXCEPTION: Group R-3 Occupancy and the dwelling unit portions of Group R-1 Occupancy.

101.3.3 Mixed Occupancy: When a building houses more than one occupancy, each portion of the building shall conform to the requirements for the occupancy housed therein. Where approved by the building official, where minor accessory uses do not occupy more than ten percent of the area of any floor of a building, the major use may be considered the building occupancy.

101.4 Amendments by Local Government: Except as provided in RCW 19.27A.020(7), this Code shall be the maximum and minimum energy code for Group R Occupancy in each town, city and county, no later than July 1, 1991.

[Statutory Authority: RCW 19.27A.025, 19.27A.045. 01-03-010, § 51-11-0101, filed 1/5/01, effective 7/1/01. Statutory Authority: RCW 19.27.031 and 19.27.074. 98-24-078, § 51-11-0101, filed 12/1/98, effective 7/1/99. Statutory Authority: RCW 19.27A.025 and 19.27A.045. 98-03-003, § 51-11-0101, filed 1/8/98, effective 7/1/98. Statutory Authority: RCW 19.27A.025. 93-21-052, § 51-11-0101, filed 10/18/93, effective 4/1/94. Statutory Authority: RCW 19.27A.020 and 1990 c 2. 91-01-112, § 51-11-0101, filed 12/19/90, effective 7/1/91.]

WAC 51-11-0102 Materials and equipment.

102.1 Identification: All materials and equipment shall be identified in order to show compliance with this Code.

102.2 Maintenance Information: Required regular maintenance actions shall be clearly stated and incorporated on a readily accessible label. Such label may be limited to identifying, by title or publication number, the operation and maintenance manual for that particular model and type of product. Maintenance instructions shall be furnished for any equipment which requires preventive maintenance for efficient operation.

[Statutory Authority: RCW 19.27A.020 and 1990 c 2. 91-01-112, § 51-11-0102, filed 12/19/90, effective 7/1/91.]

WAC 51-11-0103 Alternate materials—Method of construction, design or insulating systems. The provisions of this Code are not intended to prevent the use of any material, method of construction, design or insulating system not specifically prescribed herein, provided that such construction, design or insulating system has been approved by the building official as meeting the intent of this Code. The building official may approve any such alternate provided he finds the proposed alternate meets or exceeds the provisions of this Code and that the material, method, design or work offered is for the purpose intended, at least the equivalent of that prescribed in this Code, in quality, strength, effectiveness, fire-resistance, durability, safety, and efficient use and conservation of energy. The building official may require that

[Title 51 WAC—p. 30]

sufficient evidence of proof be submitted to substantiate any claims that may be made regarding performance capabilities.

[Statutory Authority: RCW 19.27A.020 and 1990 c 2. 91-01-112, § 51-11-0103, filed 12/19/90, effective 7/1/91.]

WAC 51-11-0104 Plans and specifications.

104.1 General: If required by the building official, plans and specifications shall be submitted in support of an application for a building permit. If required by the building official, plans and specifications shall be stamped and authenticated by a registered design professional currently licensed in the state of Washington. If required by the building official, all energy calculations submitted under the provisions of Chapter 4 for Other than Group R Occupancy shall be stamped and authenticated by an engineer or architect licensed to practice by the state. All plans and specifications, together with supporting data, shall be submitted to the building official prior to issuance of a building permit.

104.2 Details: The plans and specifications shall show in sufficient detail all pertinent data and features of the building and the equipment and systems as herein governed including, but not limited to: design criteria, exterior envelope component materials, U-factors of the envelope systems, R-values of insulating materials, size and type of apparatus and equipment, equipment and systems controls and other pertinent data to indicate compliance with the requirements of this Code.

The building official may accept the professional stamp of an architect or engineer licensed to do business by the state in lieu of a plan and specification check if the engineer or architect stipulates to the best of his knowledge, understanding and belief, the design meets the requirements of this Code.

[Statutory Authority: RCW 19.27A.025 and 19.27A.045. 98-03-003, § 51-11-0104, filed 1/8/98, effective 7/1/98. Statutory Authority: RCW 19.27A.020 and 1990 c 2. 91-01-112, § 51-11-0104, filed 12/19/90, effective 7/1/91.]

WAC 51-11-0105 Inspections and enforcement.

105.1 General: All construction or work for which a permit is required shall be subject to inspection by the building official and all such construction or work shall remain accessible and exposed for inspection purposes until approved by the building official.

105.2 Approvals Required: No work shall be done on any part of the building or structure beyond the point indicated in each successive inspection without first obtaining the approval of the building official.

105.2.1 Required Inspections: The building official, upon notification, shall make the following inspection in addition to those inspections required in section 108.5 of the Washington State Uniform Building Code:

1. Wall insulation inspection: To be made after all wall insulation and air vapor retarder sheet or film materials are in place, but before any wall covering is placed.

105.3 Reinspection: The building official may require a structure to be reinspected.

[Statutory Authority: Chapters 19.27 and 19.27A RCW and 1994 c 226. 95-01-126, § 51-11-0105, filed 12/21/94, effective 6/30/95. Statutory Authority: RCW 19.27A.020 and 1990 c 2. 91-01-112, § 51-11-0105, filed 12/19/90, effective 7/1/91.]

WAC 51-11-0106 Violations. It shall be unlawful for any person, firm, or corporation to erect or construct any building, or remodel or rehabilitate any existing building or structure in the state, or allow the same to be done, contrary to or in violation of any of the provisions of this Code.

[Statutory Authority: RCW 19.27A.020 and 1990 c 2. 91-01-112, § 51-11-0106, filed 12/19/90, effective 7/1/91.]

WAC 51-11-0107 Liability. Nothing contained in this Code is intended to be nor shall be construed to create or form the basis for any liability on the part of any city or county or its officers, employees or agents for any injury or damage resulting from the failure of a building to conform to the provisions of this Code.

[Statutory Authority: RCW 19.27A.020 and 1990 c 2. 91-01-112, § 51-11-0107, filed 12/19/90, effective 7/1/91.]

WAC 51-11-0108 Conflicts with other codes. In addition to the requirements of this Code, all occupancies shall conform to the provisions included in the State Building Code (chapter 19.27 RCW) and Uniform Building Code and Standards Adoption and Amendment rules (chapter 51-30 WAC). In case of conflicts among codes enumerated in RCW 19.27.031 (1), (2), (3), and (4) and this Code, the first named code shall govern over the following. Provided, in the case of conflict between the duct insulation requirements of this Code and the duct sealing and insulation requirements of Table 6-D of the State Mechanical Code (chapter 51-32 WAC), the duct insulation requirements of this Code, or where applicable, a local jurisdiction's energy code shall govern.

Where, in any specific case, different sections of this Code specify different materials, methods of construction or other requirements, the most restrictive shall govern. Where there is a conflict between a general requirement and a specific requirement, the specific requirement shall be applicable. Wherever in this Code reference is made to the appendix, the provisions in the appendix shall not apply unless specifically adopted.

[Statutory Authority: RCW 19.27A.020, 19.27A.045. 02-24-076, § 51-11-0108, filed 12/4/02, effective 5/1/03. Statutory Authority: Chapters 19.27 and 19.27A RCW and 1994 c 226. 95-01-126, § 51-11-0108, filed 12/21/94, effective 6/30/95. Statutory Authority: RCW 19.27A.020 and 1990 c 2. 91-01-112, § 51-11-0108, filed 12/19/90, effective 7/1/91.]

WAC 51-11-0109 Severability. If any provision of this Code or its application to any person or circumstance is held invalid, the remainder of this Code or the application of the provision to other persons or circumstances is not affected.

[Statutory Authority: RCW 19.27A.020 and 1990 c 2. 91-01-112, § 51-11-0109, filed 12/19/90, effective 7/1/91.]

(2003 Ed.)

WAC 51-11-0200 Chapter 2—Definitions.

[Statutory Authority: RCW 19.27A.020 and 1990 c 2. 91-01-112, § 51-11-0200, filed 12/19/90, effective 7/1/91.]

WAC 51-11-0201 Scope. The following definitions shall apply to chapters 1 through 20.

201.1 Application of Terms: For the purposes of this Code, certain abbreviations, terms, phrases, words and their derivatives, shall be as set forth in this chapter. Where terms are not defined, they shall have their ordinary accepted meanings within the context with which they are used. In the event there is a question about the definition of a term, the definitions for terms in the codes enumerated in RCW 19.27.031 and the edition of Webster's dictionary referenced therein shall be considered as the sources for providing ordinarily accepted meanings.

Addition: See the Washington State Building Code.

Advanced framed ceiling: Advanced framing assumes full and even depth of insulation extending to the outside edge of exterior walls. (See Standard Framing and Section 1007.2 of this Code.)

Advanced framed walls: Studs framed on twenty-four inch centers with double top plate and single bottom plate. Corners use two studs or other means of fully insulating corners, and one stud is used to support each header. Headers consist of double 2X material with R-10 insulation between the header and exterior sheathing. Interior partition wall/exterior wall intersections are fully insulated in the exterior wall. (See Standard Framing and Section 1005.2 of this Code.)

AFUE. Annual fuel utilization efficiency: Unlike steady state conditions, this rating is based on average usage including on and off cycling as set out in the standardized Department of Energy Test Procedures.

Air conditioning, comfort: The process of treating air to control simultaneously its temperature, humidity, cleanliness and distribution to meet requirements of the conditioned space.

ARI: Air-Conditioning and Refrigeration Institute.

ASHRAE: American Society of Heating, Refrigerating and Air Conditioning Engineers, Inc.

ASTM: American Society for Testing and Materials

Automatic: Self-acting, operating by its own mechanism when actuated by some impersonal influence, as for example, a change in current strength, pressure, temperature or mechanical configuration. (See **Manual**.)

Below grade walls: Walls or the portion of walls which are entirely below the finish grade or which extend two feet or less above the finish grade.

Boiler capacity: The rate of heat output in Btu/h measured at the boiler outlet, at the design inlet and outlet conditions and rated fuel/energy input.

Building envelope: For Group R Occupancy, the elements of a building which enclose conditioned spaces through which thermal energy may be transferred to or from the exterior or to or from spaces exempted by the provisions of Section 101.3.1. For other than Group R Occupancy, the elements of a building which enclose conditioned spaces

through which thermal energy may be transferred to or from the exterior, or to or from unconditioned spaces, or to or from semi-heated spaces, or to or from spaces exempted by the provisions of Section 1301.

Building, existing: See the Washington State Building Code.

Building official: The official authorized to act in behalf of a jurisdiction code enforcement agency or its authorized representative.

Building project: A building or group of buildings, including on-site energy conversion or electric-generating facilities, which utilize a single submittal for a construction permit or are within the boundary of a contiguous area under one ownership.

Conditioned floor area: (See Gross conditioned floor area.)

Conditioned space: A cooled space, heated space (fully heated), heated space (semi-heated) or indirectly conditioned space.

Cooled space: An enclosed space within a building that is cooled by a cooling system whose sensible capacity

a. exceeds 5 Btu/(h · ft²), or

b. is capable of maintaining space dry bulb temperature of 90°F or less at design cooling conditions.

COP - Coefficient of performance: The ratio of the rate of net heat output (heating mode) or heat removal (cooling mode) to the rate of total on-site energy input to the heat pump, expressed in consistent units and under designated rating conditions. (See Net Heat Output, Net Heat Removal, Total On-Site Energy Input.)

Daylighted zone:

a. Under overhead glazing: The area under overhead glazing whose horizontal dimension, in each direction, is equal to the overhead glazing dimension in that direction plus either the floor to ceiling height or the dimension to a ceiling height opaque partition, or one-half the distance to adjacent overhead or vertical glazing, whichever is least.

b. At vertical glazing: The area adjacent to vertical glazing which receives daylighting from the glazing. For purposes of this definition and unless more detailed daylighting analysis is provided, the daylighting zone depth is assumed to extend into the space a distance of 15 feet or to the nearest ceiling height opaque partition, whichever is less. The daylighting zone width is assumed to be the width of the window plus either two feet on each side (the distance to an opaque partition) or one-half the distance to adjacent overhead or vertical glazing, whichever is least.

Daylight sensing control (DS): A device that automatically regulates the power input to electric lighting near the glazing to maintain the desired workplace illumination, thus taking advantage of direct or indirect sunlight.

Deadband: The temperature range in which no heating or cooling is used.

Design cooling conditions: The cooling outdoor design temperature from the 0.5% column for summer from the Puget Sound Chapter of ASHRAE publication "Recommended Outdoor Design Temperatures, Washington State, ASHRAE."

Design heating conditions: The heating outdoor design temperature from the 0.6% column for winter from the Puget Sound Chapter of ASHRAE publication "Recommended Outdoor Design Temperatures, Washington State, ASHRAE."

Door: All operable opening areas, which are not glazing, in the building envelope including swinging and roll-up doors, fire doors, smoke vents and access hatches.

Door area: Total area of door measured using the rough opening and including the door and frame.

Dwelling unit: See the Washington State Building Code.

EER. Energy efficiency ratio: The ratio of net equipment cooling capacity in Btu/h to total rate of electric input in watts under designated operating conditions.

Economizer, air: A ducting arrangement and automatic control system that allows a cooling supply fan system to supply outside air to reduce or eliminate the need for mechanical refrigeration during mild or cold weather.

Economizer, water: A system by which the supply air of a cooling system is cooled directly, indirectly or both, by evaporation of water or by other appropriate fluid in order to reduce or eliminate the need for mechanical refrigeration.

Efficiency, HVAC system: The ratio of useful energy (at the point of use) to the energy input for a designated time period, expressed in percent.

Emissivity: The ability to absorb infrared radiation. A low emissivity implies a higher reflectance of infrared radiation.

Energy: The capacity for doing work; taking a number of forms which may be transformed from one into another, such as thermal (heat), mechanical (work), electrical and chemical; in customary units, measured in kilowatt-hours (kWh) or British thermal units (Btu). (See **New energy**.)

Energy, recovered: (See **Recovered energy**.)

Exterior envelope: (See **Building envelope**.)

Facade area: Vertical projected area including nonhorizontal roof area, overhangs, cornices, etc. measured in elevation in a vertical plane parallel to the plane of the building face.

Floor over unconditioned space: A floor which separates a conditioned space from an unconditioned space which is buffered from exterior ambient conditions including vented crawl spaces and unconditioned basements or other similar spaces, or exposed to exterior ambient conditions including open parking garages and enclosed garages which are mechanically ventilated.

F-Factor: The perimeter heat loss factor expressed in Btu/hr · ft · °F.

F-Value: (See F-Factor.)

Garden window: A multi-sided glazing product that projects beyond the plane of the wall.

Glazed wall system: A category of site assembled fenestration products used in the NFRC 100 and NFRC 200 rating procedures that include curtainwalls.

Glazing: All areas, including the frames, in the shell of a conditioned space that let in natural light including win-

dows, clerestories, skylights, sliding or swinging glass doors and glass block walls.

Glazing area: Total area of the glazing measured using the rough opening, and including the glazing, sash, and frame. For doors where the daylight opening area is less than 50% of the door area, the glazing area is the daylight opening area. For all other doors, the glazing area is the door area.

Gross conditioned floor area: The horizontal projection of that portion of interior space which is contained within exterior walls and which is conditioned directly or indirectly by an energy-using system, and which has an average height of five feet or greater, measured from the exterior faces.

Gross exterior wall area: The normal projection of the building envelope wall area bounding interior space which is conditioned by an energy-using system and which separates conditioned space from: Unconditioned space, or semi-heated space, or exterior ambient conditions or earth; includes opaque wall, vertical glazing and door areas. The gross area of walls consists of all opaque wall areas, including foundation walls, between floor spandrels, peripheral edges of floors, vertical glazing areas and door areas, where such surfaces are exposed to exterior ambient conditions and enclose a conditioned space including interstitial areas between two such spaces. (See Below grade wall.)

Gross floor area: The sum of the areas of the several floors of the building, including basements, cellars, mezzanine and intermediate floored tiers and penthouses of head-room height, measured from the exterior faces of exterior walls or from the center line of walls separating buildings, but excluding: Covered walkways, open roofed-over areas, porches and similar spaces. Pipe trenches, exterior terraces or steps, chimneys, roof overhangs and similar features.

Gross roof/ceiling area: A roof/ceiling assembly shall be considered as all components of the roof/ceiling envelope through which heat flows, thus creating a building transmission heat loss or gain, where such assembly is exposed to exterior ambient conditions and encloses a conditioned space. The assembly does not include those components that are separated from a heated and/or cooled space by a vented airspace. The gross area of a roof/ceiling assembly consists of the total interior surface of such assembly, including overhead glazing.

Guest room: See the Washington State Building Code.

Heat: The form of energy that is transferred by virtue of a temperature difference.

Heat storage capacity: The physical property of materials (mass) located inside the building envelope to absorb, store, and release heat.

Heated space (Fully heated): An enclosed space within a building, including adjacent connected spaces separated by an uninsulated component (e.g., basements, utility rooms, garages, corridors), which is heated by a heating system whose output capacity is

a. Capable of maintaining a space dry-bulb temperature of 45°F or greater at design heating conditions; or

b. 8 Btu/(h • ft²) or greater in Climate Zone 1 and 12 Btu/(h • ft²) or greater in Climate Zone 2.

Heated space (Semi-heated): An enclosed space within a building, including adjacent connected spaces sepa-

rated by an uninsulated component (e.g., basements, utility rooms, garages, corridors), which is heated by a heating system

a. Whose output capacity is 3 Btu/(h • ft²) or greater in Climate Zone 1 and 5 Btu/(h • ft²) or greater in Climate Zone 2; and

b. Is not a Heated Space (Fully Heated).

HSPF. Heating season performance factor: The total heating output (in Btu) of a heat pump during its normal annual usage period for heating divided by the total (watt hour) electric power input during the same period, as determined by test procedures consistent with the U.S. Department of Energy "Test Procedure for Central Air Conditioners, Including Heat Pumps" published in Standard RS-30. When specified in Btu per watt hour an HSPF of 6.826 is equivalent to a COP of 2.0.

Humidistat: A regulatory device, actuated by changes in humidity, used for automatic control of relative humidity.

HVAC: Heating, ventilating and air conditioning.

HVAC system components: HVAC system components provide, in one or more factory-assembled packages, means for chilling and/or heating water with controlled temperature for delivery to terminal units serving the conditioned spaces of the buildings. Types of HVAC system components include, but are not limited to, water chiller packages, reciprocating condensing units and water source (hydronic) heat pumps. (See HVAC system equipment.)

HVAC system efficiency: (See Efficiency, HVAC system.)

HVAC system equipment: HVAC system equipment provides, in one (single package) or more (split system) factory-assembled packages, means for air circulation, air cleaning, air cooling with controlled temperature and dehumidification; and optionally, either alone or in combination with a heating plant, the functions of heating and humidifying. The cooling function may be either electrically or heat operated and the refrigerant condenser may be air, water or evaporatively cooled. Where the equipment is provided in more than one package, the separate packages shall be designed by the manufacturer to be used together. The equipment may provide the heating function as a heat pump or by the use of electric elements. (The word "equipment" used without modifying adjective may, in accordance with common industry usage, apply either to HVAC system equipment or HVAC system components.)

Indirectly conditioned space: An enclosed space within a building that is not a heated or cooled space, whose area weighted heat transfer coefficient to heated or cooled spaces exceeds that to the outdoors or to unconditioned spaces; or through which air from heated or cooled spaces is transferred at a rate exceeding three air changes per hour. Enclosed corridors between conditioned spaces shall be considered as indirectly conditioned space. (See Heated Space, Cooled Space and Unconditioned Space.)

Infiltration: The uncontrolled inward air leakage through cracks and interstices in any building element and around windows and doors of a building caused by the pressure effects of wind and/or the effect of differences in the indoor and outdoor air density.

Insulation baffle: A rigid material, resistant to wind driven moisture, the purpose of which is to allow air to flow freely into the attic or crawl space and to prevent insulation from blocking the ventilation of these spaces, or the loss of insulation. Example materials for this purpose are sheet metal, or wax impregnated cardboard.

Insulation position:

a. **Exterior Insulation Position:** A wall having all or nearly all of its mass exposed to the room air with the insulation on the exterior of the mass.

b. **Integral Insulation Position:** A wall having mass exposed to both room and outside air, with substantially equal amounts of mass on the inside and outside of the insulation layer.

c. **Interior Insulation Position:** A wall not meeting either of the above definitions; particularly a wall having most of its mass external to the insulation layer.

IPLV—Integrated part-load value: A single number figure of merit based on part-load EER or COP expressing part-load efficiency for air conditioning and heat pump equipment on the basis of weighted operation at various load capacities for the equipment as specified in the Air-Conditioning and Refrigeration Institute (ARI) and Cooling Tower Institute (CTI) procedures.

Luminaire: A complete lighting unit consisting of a lamp or lamps together with the parts designed to distribute the light, to position and protect the lamps and to connect the lamps to the electric power supply.

Manual: Capable of being operated by personal intervention. (See **Automatic**.)

Microcell: A wireless communication facility consisting of an antenna that is either: (a) Four (4) feet in height and with an area of not more than 580 square inches; or (b) if a tubular antenna, no more than four (4) inches in diameter and no more than six (6) feet in length; and the associated equipment cabinet that is six (6) feet or less in height and no more than 48 square feet in floor area.

NFPA: National Fire Protection Association.

NFRC: National Fenestration Rating Council.

Net heat output: The change in the total heat content of the air entering and leaving the equipment (not including supplementary heat and heat from boilers).

Net heat removal: The total difference in heat content of the air entering and leaving the equipment (without heat) or the difference in total heat content of the water or refrigerant entering and leaving the component.

New energy: Energy, other than recovered energy, utilized for the purpose of heating or cooling. (See **energy**.)

Nominal R-value: The thermal resistance of insulation as specified by the manufacturer according to recognized trade and engineering standards.

Nonrenewable energy sources: All energy sources that are not renewable energy sources including natural gas, oil, coal, wood, liquified petroleum gas, steam, and any utility-supplied electricity.

Nonresidential: All buildings and spaces in the Uniform Building Code (UBC) occupancies other than Group R.

Occupancy: See the Washington State Building Code.

Occupancy sensor: A device that detects occupants within an area, causing any combination of lighting, equipment or appliances to be turned on or shut off.

Opaque envelope areas: All exposed areas of a building envelope which enclose conditioned space, except openings for doors, glazing and building service systems.

Open blown: Loose fill insulation pneumatically installed in an unconfined attic space.

Outdoor air (outside air): Air taken from the outdoors and, therefore, not previously circulated through a building.

Overhead glazing: A glazing surface that has a slope of less than 60° from the horizontal plane.

Packaged terminal air conditioner: A factory-selected combination of heating and cooling components, assemblies or sections intended to serve a room or zone. (For the complete technical definition, see Standard RS-10.)

Permeance (perm): The ability of a material of specified thickness to transmit moisture in terms of amount of moisture transmitted per unit time for a specified area and differential pressure (grains per hour · ft² · inches of HG). Permeance may be measured using ASTM E-96-72 or other approved dry cup method as specified in RS-27.

Personal wireless service facility: A Wireless Communication Facility (WCF), including a microcell, which is a facility for the transmission and/or reception of radio frequency signals and which may include antennas, equipment shelter or cabinet, transmission cables, a support structure to achieve the necessary elevation, and reception and/or transmission devices or antennas.

Pool cover: A vapor-retardant cover which lies on or at the surface of the pool.

Power: In connection with machines, the time rate of doing work. In connection with the transmission of energy of all types, the rate at which energy is transmitted; in customary units, it is measured in watts (W) or British Thermal Units per hour (Btu/h).

Process energy: Energy consumed in support of a manufacturing, industrial, or commercial process other than the maintenance of building comfort or amenities for building occupants.

Radiant slab floor: A slab floor assembly on grade or below, containing heated pipes, ducts, or electric heating cables that constitute a floor or portion thereof for complete or partial heating of the structure.

Readily accessible: See the Washington State Mechanical Code.

Recooling: The removal of heat by sensible cooling of the supply air (directly or indirectly) that has been previously heated above the temperature to which the air is to be supplied to the conditioned space for proper control of the temperature of that space.

Recovered energy: Energy utilized which would otherwise be wasted (i.e. not contribute to a desired end use) from an energy utilization system.

Reheat: The application of sensible heat to supply air that has been previously cooled below the temperature of the conditioned space by either mechanical refrigeration or the introduction of outdoor air to provide cooling.

Renewable energy sources: Renewable energy sources of energy (excluding minerals) are derived from: (1) Incoming solar radiation, including but not limited to, natural daylighting and photosynthetic processes; (2) Energy sources resulting from wind, waves and tides, lake or pond thermal differences; and (3) energy derived from the internal heat of the earth, including nocturnal thermal exchanges.

Reset: Adjustment of the set point of a control instrument to a higher or lower value automatically or manually to conserve energy.

Roof/ceiling assembly: (See Gross roof/ceiling area.)

SEER - Seasonal Energy Efficiency Ratio: The total cooling output of an air conditioner during its normal annual usage period, in Btu's, divided by the total electric energy input in watt-hours, during the same period, as determined by 10 CFR, Part 430.

Semi-heated space: Sub-category of **Heated Space**. (See **Heated Space**.)

Sequence: A consecutive series of operations.

Service systems: All energy-using systems in a building that are operated to provide services for the occupants or processes housed therein, including HVAC, service water heating, illumination, transportation, cooking or food preparation, laundering or similar functions.

Service water heating: Supply of hot water for domestic or commercial purposes other than comfort heating.

Shaded: Glazed area which is externally protected from direct solar radiation by use of devices permanently affixed to the structure or by an adjacent building, topographical feature, or vegetation.

Shading coefficient: The ratio of solar heat gain occurring through nonopaque portions of the glazing, with or without integral shading devices, to the solar heat gain occurring through an equivalent area of unshaded, 1/8 inch thick, clear, double-strength glass.

Note: Heat gains to be compared under the same conditions. See Chapter 28 of Standard RS-27, listed in Chapter 7 of this Code.

Shall: Denotes a mandatory code requirement.

Single family: One and two family residential dwelling units with no more than two units in a single building.

Skylight: (See Overhead glazing.)

Slab-below-grade: Any portion of a slab floor in contact with the ground which is more than 24 inches below the final elevation of the nearest exterior grade.

Slab-on-grade, exterior: Any portion of a slab floor in contact with the ground which is less than or equal to twenty-four inches below the final elevation of the nearest exterior grade.

Small business: Any business entity (including a sole proprietorship, corporation, partnership, or other legal entity) which is owned and operated independently from all other businesses, which has the purpose of making a profit, and which has fifty or fewer employees, or which has a million dollars or less per year in gross sales, of window products.

Solar energy source: Source of natural daylighting and of thermal, chemical or electrical energy derived directly from conversion of incident solar radiation.

Solar heat gain coefficient (SHGC): The ratio of the solar heat gain entering the space through the glazing product to the incident solar radiation. Solar heat gain includes directly transmitted solar heat and absorbed solar radiation which is then reradiated, conducted or convected into the space.

Split system: Any heat pump or air conditioning unit which is provided in more than one assembly requiring refrigeration piping installed in the field.

Standard framing: All framing practices not defined as "intermediate" or "advanced" shall be considered standard. (See Advanced framed ceiling, Advanced framed walls, Intermediate framed wall and Section 1005.2 of this Code.)

Substantial contact: A condition where adjacent building materials are placed in a manner that proximal surfaces are contiguous, being installed and supported as to eliminate voids between materials, without compressing or degrading the thermal performance of either product.

System: A combination of central or terminal equipment or components and/or controls, accessories, interconnecting means, and terminal devices by which energy is transformed so as to perform a specific function, such as HVAC, service water heating or illumination.

Tapering: Installation of a reduced level of ceiling insulation at the eaves, due to reduced clearance.

Thermal by-pass: An area where the envelope surrounding the conditioned space is breached, or where an ineffective application compromises the performance of a thermal or infiltration barrier, increasing the structure's energy consumption by exposing finished surfaces to ambient conditions and additional heat transfer.

Thermal conductance (C): Time rate of heat flow through a body (frequently per unit area) from one of its bounding surfaces to the other for a unit temperature difference between the two surfaces, under steady conditions (Btu/hr·ft²·°F).

Thermal resistance (R): The reciprocal of thermal conductance (hr · ft² · °F/Btu).

Thermal transmittance (U): The coefficient of heat transmission (air to air). It is the time rate of heat flow per unit area and unit temperature difference between the warm side and cold side air films (Btu/hr · ft² · °F).

Thermal transmittance, overall (U_o): The overall (average) heat transmission of a gross area of the exterior building envelope (Btu/hr · ft² · °F). The U_o-factor applies to the combined effect of the time rate of heat flows through the various parallel paths, such as glazing, doors and opaque construction areas, comprising the gross area of one or more exterior building components, such as walls, floors or roof/ceiling.

Thermostat: An automatic control device actuated by temperature and designed to be responsive to temperature.

Total on-site energy input: The combination of all the energy inputs to all elements and accessories as included in the equipment components, including but not limited to, compressor(s), compressor sump heater(s), circulating pump(s), purge devices, fan(s), and the HVAC system component control circuit.

Transmission coefficient: The ratio of the solar heat gain through a glazing system to that of an unshaded single pane of double strength window glass under the same set of conditions.

Transverse joint: The primary connection between air distribution system fittings.

U-factor: (See **thermal transmittance**.)

U-Value: (See **U-factor**.)

Uniform Building Code (UBC): (See Washington State Building Code.)

Uniform Mechanical Code (UMC): (See Washington State Mechanical Code.)

Uniform Plumbing Code (UPC): (See Washington State Plumbing Code.)

Unitary cooling and heating equipment: One or more factory-made assemblies which include an evaporator or cooling coil, a compressor and condenser combination, and may include a heating function as well. Where such equipment is provided in more than one assembly, the separate assemblies shall be designed to be used together.

Unitary heat pump: One or more factory-made assemblies which include an indoor conditioning coil, compressor(s) and outdoor coil or refrigerant-to-water heat exchanger, including means to provide both heating and cooling functions. When such equipment is provided in more than one assembly, the separate assemblies shall be designed to be used together.

Vapor retarder: A layer of low moisture transmissivity material (not more than 1.0 perm dry cup) placed over the warm side (in winter) of insulation, over the exterior of below grade walls, and under floors as ground cover to limit the transport of water and water vapor through exterior walls, ceilings, and floors. Vapor retarding paint, listed for this application, also meets this definition.

Vaulted ceilings: All ceilings where enclosed joist or rafter space is formed by ceilings applied directly to the underside of roof joists or rafters.

Ventilation: The process of supplying or removing air by natural or mechanical means to or from any space. Such air may or may not have been conditioned.

Ventilation air: That portion of supply air which comes from outside (outdoors) plus any recirculated air that has been treated to maintain the desired quality of air within a designated space.

Vertical glazing: A glazing surface that has a slope of 60° or greater from the horizontal plane.

Walls (exterior): Any member or group of members which defines the exterior boundaries or courts of a building and which have a slope of sixty degrees or greater with the horizontal plane, and separates conditioned from unconditioned space. Band joists between floors are to be considered a part of exterior walls.

Washington State Building Code: The building code as modified by the Washington State Building Code Council.

Washington State Mechanical Code: The mechanical code as modified by the Washington State Building Code Council.

Washington State Plumbing Code: The plumbing code as modified by the Washington State Building Code Council.

Zone: A space or group of spaces within a building with heating and/or cooling requirements sufficiently similar so that comfort conditions can be maintained throughout by a single controlling device. Each dwelling unit in residential buildings shall be considered a single zone.

[Statutory Authority: RCW 19.27A.020, 19.27A.045. 02-24-076, § 51-11-0201, filed 12/4/02, effective 5/1/03. Statutory Authority: RCW 19.27A.025, 19.27A.045. 01-03-010, § 51-11-0201, filed 1/5/01, effective 7/1/01; 98-03-003, § 51-11-0201, filed 1/8/98, effective 7/1/98. Statutory Authority: Chapters 19.27, 19.27A and 34.05 RCW. 94-05-059, § 51-11-0201, filed 2/10/94, effective 4/1/94. Statutory Authority: RCW 19.27A.025. 93-21-052, § 51-11-0201, filed 10/18/93, effective 4/1/94. Statutory Authority: RCW 19.27A.020 and 1990 c 2. 91-01-112, § 51-11-0201, filed 12/19/90, effective 7/1/91.]

WAC 51-11-0300 Chapter 3—Design conditions.

[Statutory Authority: RCW 19.27A.020 and 1990 c 2. 91-01-112, § 51-11-0300, filed 12/19/90, effective 7/1/91.]

WAC 51-11-0301 Design criteria.

301.1 General:

The criteria of this chapter establish the design conditions upon which the minimum thermal design requirements of the building envelope and the design of the HVAC system are to be based.

301.2 Heating and Cooling: A building that is designed to be both heated and cooled shall meet the more stringent of the heating or cooling requirements as required in this code when requirements of the exterior envelope differ.

[Statutory Authority: RCW 19.27A.020 and 1990 c 2. 91-01-112, § 51-11-0301, filed 12/19/90, effective 7/1/91.]

WAC 51-11-0302 Thermal design parameters.

302.1 Exterior Design Conditions: The heating or cooling outdoor design temperatures shall be selected from 0.6 percent column for winter and 0.5 percent column for summer from the Puget Sound Chapter of ASHRAE publication "Recommended Outdoor Design Temperatures, Washington State, ASHRAE." (See also Washington State Energy Code Manual.)

302.2 Interior Design Conditions:

302.2.1 Indoor Design Temperature: Indoor design temperature shall be seventy degrees F for heating and seventy-eight degrees F for cooling.

EXCEPTION: Other design temperatures may be used for equipment selection if it results in a lower energy usage.

302.2.2 Humidification: If humidification is provided during heating, it shall be designed for a maximum relative humidity of thirty percent. When comfort air conditioning is provided, the actual design relative humidity within the comfort envelope as defined in Standard RS-4, listed in Chapter 7, shall be selected for minimum total HVAC system energy use.

302.3 Climate Zones: All buildings shall comply with the requirements of the appropriate climate zone as defined herein.

ZONE 1: Climate Zone 1 shall include all counties not included in Climate Zone 2.

ZONE 2: Climate Zone 2 shall include: Adams, Chelan, Douglas, Ferry, Grant, Kittitas, Lincoln, Okanogan, Pend Oreille, Spokane, Stevens, and Whitman counties.

[Statutory Authority: RCW 19.27A.020 and 1990 c 2. 91-01-112, § 51-11-0302, filed 12/19/90, effective 7/1/91.]

WAC 51-11-0303 Mechanical ventilation. For all Occupancies, the minimum requirements for ventilation shall comply with the Washington State Ventilation Code and Indoor Air Quality Code. (WAC 51-13)

[Statutory Authority: RCW 19.27A.020 and 1990 c 2. 91-01-112, § 51-11-0303, filed 12/19/90, effective 7/1/91.]

WAC 51-11-0400 Chapter 4—Building design by systems analysis.

[Statutory Authority: RCW 19.27A.020 and 1990 c 2. 91-01-112, § 51-11-0400, filed 12/19/90, effective 7/1/91.]

WAC 51-11-0401 Scope.

401.1 General: This chapter establishes design criteria in terms of total energy use by a building, including all of its systems. Analysis of design for all Group R Occupancy shall comply with section 402.1 to 402.6.

[Statutory Authority: RCW 19.27A.025, 93-21-052, § 51-11-0401, filed 10/18/93, effective 4/1/94. Statutory Authority: RCW 19.27A.020 and 1990 c 2. 91-01-112, § 51-11-0401, filed 12/19/90, effective 7/1/91.]

WAC 51-11-0402 Systems analysis.

402.1 Special Requirements for All Group R Occupancy:

402.1.1 Energy Budgets: Proposed buildings designed in accordance with this section shall be designed to use no more energy from nonrenewable sources for space heating, and domestic hot water heating than a standard building whose enclosure elements and energy consuming systems are designed in accordance with section 502.2 of this Code for the appropriate climate zone, and heating system type. Energy derived from renewable sources may be excluded from the total annual energy consumption attributed to the alternative building.

402.1.2 Calculation of Energy Consumption: The application for a building permit shall include documentation which demonstrates, using a calculation procedure as listed in Chapter 8, or an approved alternate, that the proposed building's annual space heating energy use does not exceed the annual space heating and water heating energy use of a standard building conforming to Chapter 5 of this Code for the appropriate climate zone. The total calculated annual energy consumption shall be shown in units of kWh/ft²/year or Btu/ft²/year of conditioned area.

(2003 Ed.)

402.1.3 Input Values: The following standardized input values shall be used in calculating annual space heating budgets:

PARAMETER	VALUE
Thermostat set point, heating	65° F
Thermostat set point, cooling	78° F
Thermostat night set back	65° F
Thermostat night set back period	0 hours
Internal gain	
R-3 units	3000 Btu/hr
R-1 units	1500 Btu/hr
Domestic Hot Water Heater Setpoint	120° F
Domestic Hot Water Consumption	20 gallons/person/day.
Minimum heat storage	Calculated using standard engineering practice for the actual building or as approved.
Site weather data	Typical meteorological year (TMY) or ersatz TMY data for the closest appropriate TMY site or other sites as approved.
Heating equipment efficiency	
Electric resistance heat	1.00
Heat Pumps	6.80 HSPF.
Other Fuels	0.78 AFUE.

The standard building shall be modeled with glazing area distributed equally among the four cardinal directions. Parameter values that may be varied by the building designer to model energy saving options include, but are not limited to, the following:

1. Overall thermal transmittance, U_o, of building envelope or individual building components;
2. Heat storage capacity of building;
3. Glazing orientation; area; and solar heat coefficients;
4. Heating system efficiency.

402.1.4 Solar Shading and Access: Building designs using passive solar features with eight percent or more south facing equivalent glazing to qualify shall provide to the building official a sun chart or other approved documentation depicting actual site shading for use in calculating compliance under this section. The building shall contain at least forty-five Btu/°F for each square foot of south facing glass.

402.1.5 Infiltration: Infiltration levels used shall be set at 0.35 air changes per hour for thermal calculation purposes only.

402.1.6 Heat Pumps: The heating season performance factor (HSPF) for heat pumps shall be calculated using procedures consistent with section 5.2 of the U.S. Department of Energy Test Procedure for Central Air Conditioners, includ-

ing heat pumps published in the December 27, 1979 Federal Register Vol. 44, No. 24. 10 CFR 430. Climate data as specified above, the proposed buildings overall thermal performance value (Btu/°F) and the standardized input assumptions specified above shall be used to model the heat pumps HSPF.

402.2 Energy Analysis: Compliance with this chapter will require an analysis of the annual energy usage, hereinafter called an annual energy analysis.

EXCEPTIONS: Chapters 5, and 6 of this Code establish criteria for different energy-consuming and enclosure elements of the building which, will eliminate the requirement for an annual systems energy analysis while meeting the intent of this Code.

A building designed in accordance with this chapter will be deemed as complying with this Code if the calculated annual energy consumption is not greater than a similar building (defined as a "standard design") whose enclosure elements and energy-consuming systems are designed in accordance with Chapter 5.

For an alternate building design to be considered similar to a "standard design," it shall utilize the same energy source(s) for the same functions and have equal floor area and the same ratio of envelope area to floor area, environmental requirements, occupancy, climate data and usage operational schedule.

402.3 Design: The standard design, conforming to the criteria of Chapter 5 and the proposed alternative design shall be designed on a common basis as specified herein:

The comparison shall be expressed as kBtu or kWh input per square foot of conditioned floor area per year at the building site.

402.4 Analysis Procedure: The analysis of the annual energy usage of the standard and the proposed alternative building and system design shall meet the following criteria:

a. The building heating/cooling load calculation procedure used for annual energy consumption analysis shall be detailed to permit the evaluation of effect of factors specified in section 402.5.

b. The calculation procedure used to simulate the operation of the building and its service systems through a full-year operating period shall be detailed to permit the evaluation of the effect of system design, climatic factors, operational characteristics, and mechanical equipment on annual energy usage. Manufacturer's data or comparable field test data shall be used when available in the simulation of systems and equipment. The calculation procedure shall be based upon eight thousand seven hundred sixty hours of operation of the building and its service systems.

402.5 Calculation Procedure: The calculation procedure shall cover the following items:

a. Design requirements—Environmental requirements as required in Chapter 3.

b. Climatic data—Coincident hourly data for temperatures, solar radiation, wind and humidity of typical days in the year representing seasonal variation.

c. Building data—Orientation, size, shape, mass, air, moisture and heat transfer characteristics.

d. Operational characteristics—Temperature, humidity, ventilation, illumination, control mode for occupied and unoccupied hours.

e. Mechanical equipment—Design capacity, part load profile.

f. Building loads—Internal heat generation, lighting, equipment, number of people during occupied and unoccupied periods.

EXCEPTION: Group R Occupancy shall comply with calculation procedures in Chapter 8, or an approved alternate.

402.6 Documentation: Proposed alternative designs, submitted as requests for exception to the standard design criteria, shall be accompanied by an energy analysis comparison report. The report shall provide technical detail on the two building and system designs and on the data used in and resulting from the comparative analysis to verify that both the analysis and the designs meet the criteria of Chapter 4 of this Code.

[Statutory Authority: RCW 19.27A.025 and 19.27A.045, 98-03-003, § 51-11-0402, filed 1/8/98, effective 7/1/98. Statutory Authority: Chapters 19.27, 19.27A and 34.05 RCW, 94-05-059, § 51-11-0402, filed 2/10/94, effective 4/1/94. Statutory Authority: RCW 19.27A.020 and 1990 c 2, 91-01-112, § 51-11-0402, filed 12/19/90, effective 7/1/91.]

WAC 51-11-0500 Chapter 5—Building design by component performance approach.

[Statutory Authority: RCW 19.27A.020 and 1990 c 2, 91-01-112, § 51-11-0500, filed 12/19/90, effective 7/1/91.]

WAC 51-11-0501 Scope.

501.1 General: Buildings that are heated or mechanically cooled shall be constructed so as to provide the required thermal performance of the various components. A building that is designed to be both heated and cooled shall meet the more stringent of the heating or cooling requirements as provided in this Code when requirements of the exterior envelope differ.

[Statutory Authority: RCW 19.27A.020 and 1990 c 2, 91-01-112, § 51-11-0501, filed 12/19/90, effective 7/1/91.]

WAC 51-11-0502 Building envelope requirements.

502.1 General:

502.1.1: The stated U- or F-factor of any component assembly, listed in Table 5-1 or 5-2, such as roof/ceiling, opaque wall or opaque floor may be increased and the U-factor for other components decreased, provided that the total heat gain or loss for the entire building envelope does not exceed the total resulting from compliance to the U-factors specified in this Section.

The U-factors for typical construction assemblies are included in Chapter 10. These values shall be used for all calculations. Where proposed construction assemblies are not represented in Chapter 10, values shall be calculated in accordance with Chapters 21-29 in Standard RS-1 listed in Chapter 7, using the framing factors listed in Chapter 10 where applicable.

For envelope assemblies containing metal framing, the U-factor shall be determined by one of the following methods:

1. Results of laboratory or field measurements.
2. Standard RS-25, listed in Chapter 7, where the metal framing is bonded on one or both sides to a metal skin or covering.
3. The zone method as provided in Chapter 24 of Standard RS-1, listed in Chapter 7.
4. Results of parallel path correction factors effective framing/cavity R-values as provided in Table 10-5A - EFFECTIVE R-VALUES FOR METAL FRAMING AND CAVITY ONLY for metal stud walls and roof/ceilings.

502.1.2: For consideration of thermal mass effects, see section 402.4.

502.1.3: When return air ceiling plenums are employed, the roof/ceiling assembly shall:

- a. For thermal transmittance purposes, not include the ceiling proper nor the plenum space as part of the assembly; and
- b. For gross area purposes, be based upon the interior face of the upper plenum surface.

502.1.4 Insulation:

502.1.4.1 General: All insulating materials shall comply with sections 2602 and/or 707 of the Uniform Building Code. Substantial contact of the insulation with the surface being insulated is required. All insulation materials shall be installed according to the manufacturer's instructions to achieve proper densities and maintain uniform R-values and shall be installed in a manner which will permit inspection of the manufacturer's R-value identification mark. To the maximum extent possible, insulation shall extend over the full component area to the intended R-value.

Alternatively, the thickness of roof/ceiling and wall insulation that is either blown in or spray-applied shall be identified by inches of thickness, density and R-value markers installed at least one for every 300 square feet (28 m²) through the attic, ceiling and/or wall space. In attics, the markers shall be affixed to the trusses or joists and marked with the minimum initial installed thickness and minimum settled thickness with numbers a minimum 1.0 inch (25 mm) in height. Each marker shall face the attic access. The thickness of installed attic insulation shall meet or exceed the minimum initial installed thickness shown by the marker. In cathedral ceilings and walls, the markers shall be affixed to the rafter and wall frame at alternating high and low intervals and marked with the minimum installed density and R-value with numbers a minimum 1.0 inch (25 mm) in height. Each marker shall face the conditioned room area.

502.1.4.2 Insulation Materials: All insulation materials including facings such as vapor barriers or breather papers installed within floor/ceiling assemblies, roof/ceiling assemblies, walls, crawl spaces, or attics shall have a flame spread

rating of less than 25 and a smoke density not to exceed 450 when tested in accordance with UBC Standard 8-1.

- EXCEPTIONS:
1. Foam plastic insulation shall comply with section 2602 of the Uniform Building Code.
 2. When such materials are installed in concealed spaces of Types III, IV and V construction, the flame spread and smoke developed limitations do not apply to facing, provided that the facing is installed in substantial contact with the unexposed surface of the ceiling, floor or wall finish.
 3. Cellulose insulation shall comply with section 707 of the Uniform Building Code.

502.1.4.3 Clearances: Where required, insulation shall be installed with clearances according to manufacturer's specifications. Insulation shall be installed so that required ventilation is unobstructed. For blown or poured loose fill insulation, clearances shall be maintained through installation of a permanent retainer.

502.1.4.4 Access Hatches and Doors: Access doors from conditioned spaces to unconditioned spaces (e.g., attics and crawl spaces) shall be weatherstripped and insulated to a level equivalent to the insulation on the surrounding surfaces. Access shall be provided to all equipment which prevents damaging or compressing the insulation. A wood framed or equivalent baffle or retainer must be provided when loose fill insulation is installed, the purpose of which is to prevent the loose fill insulation from spilling into the living space when the attic access is opened, and to provide a permanent means of maintaining the installed R-value of the loose fill insulation.

502.1.4.5 Roof/Ceiling Insulation: Open-blown or poured loose fill insulation may be used in attic spaces where the slope of the ceiling is not more than 3 feet in 12 and there is at least 30 inches of clear distance from the top of the bottom chord of the truss or ceiling joist to the underside of the sheathing at the roof ridge. When eave vents are installed, baffling of the vent openings shall be provided so as to deflect the incoming air above the surface of the insulation. Baffles shall be, rigid material, resistant to wind driven moisture. Requirements for baffles for ceiling insulation shall meet the Uniform Building Code section 1505.3 for minimum ventilation requirements. When feasible, the baffles shall be installed from the top of the outside of the exterior wall, extending inward, to a point 6 inches vertically above the height of noncompressed insulation, and 12 inches vertically above loose fill insulation.

502.1.4.6 Wall Insulation: Insulation installed in exterior walls shall comply with the provisions of this section. All wall insulation shall fill the entire framed cavity. Exterior wall cavities isolated during framing shall be fully insulated to the levels of the surrounding walls. All faced insulation shall be face stapled to avoid compression.

502.1.4.7 Floor Insulation: Floor insulation shall be installed in a permanent manner in substantial contact with the surface being insulated. Insulation supports shall be installed so spacing is no more than 24 inches on center. Foundation vents shall be placed so that the top of the vent is below the lower surface of the floor insulation.

EXCEPTION: Insulation may be omitted from floor areas over heated basements, heated garages or underfloor areas used as HVAC supply plenums. See Uniform Mechanical Code section 607 for underfloor supply plenum requirements. When foundation walls are insulated, the insulation shall be attached in a permanent manner. The insulation shall not block the airflow through foundation vents when installed. When foundation vents are not placed so that the top of the vent is below the lower surface of the floor insulation, a permanently attached baffle shall be installed at an angle of 30° from horizontal, to divert air flow below the lower surface of the floor insulation.

502.1.4.8 Slab-On-Grade: Slab-on-grade insulation, installed inside the foundation wall, shall extend downward from the top of the slab for a minimum distance of 24 inches or downward and then horizontally beneath the slab for a minimum combined distance of 24 inches. Insulation installed outside the foundation shall extend downward to a minimum of 24 inches or to the frostline. Above grade insulation shall be protected.

EXCEPTION: For monolithic slabs, the insulation shall extend downward from the top of the slab to the bottom of the footing.

502.1.4.9 Radiant Slabs: The entire area of a radiant slab shall be thermally isolated from the soil, with a minimum of R-10 insulation. The insulation shall be an approved product for its intended use. If a soil gas control system is present below the radiant slab, which results in increased convective flow below the radiant slab, the radiant slab shall be thermally isolated from the sub-slab gravel layer.

502.1.4.10 Below Grade Walls: Below grade exterior wall insulation used on the exterior (cold) side of the wall shall extend from the top of the below grade wall to the top of the footing and shall be approved for below grade use. Above grade insulation shall be protected.

Insulation used on the interior (warm) side of the wall shall extend from the top of the below grade wall to the below grade floor level.

502.1.5 Glazing and Door U-factors: Glazing and door U-factors shall be determined in accordance with sections 502.1.5.1 and 502.1.5.2. All products shall be labeled with the NFRC certified or default U-factor. The labeled U-factor shall be used in all calculations to determine compliance with this Code. Sealed insulating glass shall conform to, or be in test for, ASTM E-774-81 class A.

EXCEPTIONS: 1. For glazed wall systems, assemblies with all of the following features are deemed to satisfy the vertical glazing U-factor requirement in Table 6-1 or 6-2 options with vertical glazing U-0.40 and greater:

a. Double glazing with a minimum 1/2 inch gap width, having a low-emissivity coating with $e = 0.10$ maximum, with 90% minimum argon gas fill, and a non-aluminum spacer (as defined in footnote 1 to Table 10-6B), and

b. Frame that is thermal break aluminum (as defined in footnote 9 to Table 10-6B), wood, aluminum clad wood, vinyl, aluminum clad vinyl, or reinforced vinyl.

The only labeling requirement for products using this exception shall be a description of the product and a label stating: "This product is deemed to satisfy the Table 6-1 or 6-2 vertical glazing U-factor requirement using the exception to Section 502.1.5 in the Washington State Energy Code."

2. For overhead glazing, assemblies with all of the following features are deemed to satisfy the overhead glazing U-factor requirement in Table 6-1 or 6-2 options **except** the unlimited glazing area options (Option III in Table 6-1 and Option IV in Table 6-2):

a. Either, double glazing with a minimum 1/2 inch gap width, having a low-emissivity coating with $e = 0.20$ maximum, with 90% minimum argon gas fill, or, triple glazed plastic domes, and

b. Frame that is thermal break aluminum (as defined in footnote 9 to Table 10-6B), wood, aluminum clad wood, vinyl, aluminum clad vinyl, or reinforced vinyl.

The only labeling requirement for products using this exception shall be a description of the product and a label stating: "This product is deemed to satisfy the Table 6-1 or 6-2 overhead glazing U-factor requirement using the exception to Section 502.1.5 in the Washington State Energy Code."

3. For solariums with a floor area which does not exceed 300 square feet, assemblies which comply with the features listed in exception 2 are deemed to satisfy the vertical glazing and overhead glazing U-factor requirement in Table 6-1 or 6-2 options with vertical glazing U-0.40 and greater.

The only labeling requirement for products using this exception shall be a description of the product and a label stating: "This product is deemed to satisfy the Table 6-1 or 6-2 vertical glazing and overhead glazing U-factor requirements using the exception to Section 502.1.5 in the Washington State Energy Code."

502.1.5.1 Standard Procedure for Determination of Glazing U-factors: U-factors for glazing shall be determined, certified and labeled in accordance with the National Fenestration Rating Council (NFRC) Product Certification Program (PCP), as authorized by an independent certification and inspection agency licensed by the NFRC. Compliance shall be based on the Residential Model Size. Product samples used for U-factor determinations shall be production line units or representative of units as purchased by the consumer or contractor. Products that are listed in the NFRC Certified Products Directory or certified to the NFRC standard shall not use default values.

EXCEPTIONS: 1. Glazing products without NFRC ratings may be assigned default U-factors from Table 10-6A for vertical glazing and from Table 10-6B for overhead glazing.

2. Units without NFRC ratings produced by a small business may be assigned default U-factors from Table 10-6A for garden windows, from Table 10-6B for other vertical glazing, and from Table 10-6E for overhead glazing.

502.1.5.2 Standard Procedure for Determination of Door U-factors: All doors, including fire doors, shall be assigned default U-factors from Table 10-6C.

EXCEPTIONS: 1. U-factors determined, certified and labeled in accordance with the National Fenestration Rating Council (NFRC) Product Certification Program (PCP), as authorized by an independent certification and inspection agency licensed by the NFRC.

2. The default values for the opaque portions of doors shall be those listed in Table 10-6C, provided that the U-factor listed for a door with a thermal break shall only be allowed if both the door and the frame have a thermal break.

3. One unlabeled or untested exterior swinging door with the maximum area of 24 square feet may be installed for ornamental, security or architectural purposes. Products using this exception shall not be included in the U-factor calculation requirements,

however glazing area shall be included in glazing area calculations.

502.1.6 Moisture Control:

502.1.6.1 Vapor Retarders: Vapor retarders shall be installed on the warm side (in winter) of insulation as specified in the following cases.

EXCEPTION: Vapor retarder installed with not more than 1/3 of the nominal R-value between it and the conditioned space.

502.1.6.2 Floors: Floors separating conditioned space from unconditioned space shall have a vapor retarder installed. The vapor retarder shall have a one perm dry cup rating or less (i.e., four mil [0.004 inch thick] polyethylene or kraft faced material).

502.1.6.3 Roof/Ceilings: Roof/ceiling assemblies where the ventilation space above the insulation is less than an average of 12 inches shall be provided with a vapor retarder. Faced batt insulation where used as a vapor retarder shall be face stapled. Single rafter joist vaulted ceiling cavities shall be of sufficient depth to allow a minimum one inch vented air space above the insulation.

502.1.6.4: Vapor retarders shall not be required in roof/ceiling assemblies where the ventilation space above the insulation averages 12 inches or greater.

502.1.6.5: Vapor retarders shall not be required where all of the insulation is installed between the roof membrane and the structural roof deck.

502.1.6.6 Walls: Walls separating conditioned space from unconditioned space shall have a vapor retarder installed. Faced batt insulation shall be face stapled.

502.1.6.7 Ground Cover: A ground cover of six mil (0.006 inch thick) black polyethylene or approved equal shall be laid over the ground within crawl spaces. The ground cover shall be overlapped 12 inches minimum at the joints and shall extend to the foundation wall.

EXCEPTION: The ground cover may be omitted in crawl spaces if the crawl space has a concrete slab floor with a minimum thickness of 3-1/2 inches.

502.2 Thermal Criteria for Group R Occupancy:

502.2.1 UA Calculations: The proposed UA as calculated using Equations 2 and 3 shall not exceed the target UA as calculated using Equation 1. For the purpose of determining equivalent thermal performance, the glazing area for the target UA shall be calculated using values in Table 5-1. The opaque door area shall be the same in the target UA and the proposed UA.

EXCEPTION: Log and solid timber walls that have a minimum average thickness of 3.5" and with space heat type other than electric resistance, are exempt from wall target UA and proposed UA calculations.

502.2.2 Space Heat Type: The following two categories comprise all space heating types:

1. Electric Resistance: Space heating systems which include baseboard units, radiant units and forced air units as either the primary or secondary heating system.

EXCEPTION: Electric resistance systems for which the total electric heat capacity in each individual dwelling unit does not exceed the greater of: 1) One thousand watts (1000 w) per dwelling unit, or; 2) One watt per square foot (1 w/ft²) of the gross floor area.

2. Other: All gas, wood, oil and propane space heating systems, unless electric resistance is used as a secondary heating system, and all heat pump space heating systems. (See EXCEPTIONS, Electric Resistance, section 502.2.2 above.)

502.3 Reserved.

502.4 Air Leakage:

502.4.1 General: The requirements of this section shall apply to all buildings and structures, or portions thereof, and only to those locations separating outdoor ambient conditions from interior spaces that are heated or mechanically cooled.

502.4.2 Doors and Windows, General: Exterior doors and windows shall be designed to limit air leakage into or from the building envelope. Site-constructed doors and windows shall be sealed in accordance with Section 502.4.3.

502.4.3 Seals and Weatherstripping:

a. Exterior joints around windows and door frames, openings between walls and foundation, between walls and roof and wall panels; openings at penetrations of utility services through walls, floors and roofs; and all other openings in the building envelope for all occupancies and all other openings in between units in R-1 occupancy shall be sealed, caulked, gasketed or weatherstripped to limit air leakage. Other exterior joints and seams shall be similarly treated, or taped, or covered with moisture vapor permeable housewrap.

b. All exterior doors or doors serving as access to an enclosed unheated area shall be weatherstripped to limit leakage around their perimeter when in a closed position.

c. Site built windows are exempt from testing but shall be made tight fitting. Fixed lights shall have glass retained by stops with sealant or caulking all around. Operating sash shall have weatherstripping working against overlapping trim and a closer/latch which will hold the sash closed. The window frame to framing crack shall be made tight with caulking, overlapping membrane or other approved technique.

d. Openings that are required to be fire resistive are exempt from this section.

502.4.4 Recessed Lighting Fixtures: When installed in the building envelope, recessed lighting fixtures shall meet one of the following requirements:

1. Type IC rated, manufactured with no penetrations between the inside of the recessed fixture and ceiling cavity and sealed or gasketed to prevent air leakage into the unconditioned space.

2. Type IC rated, installed inside a sealed box constructed from a minimum 1/2 inch thick gypsum wall board, or constructed from a preformed polymeric vapor barrier, or other air tight assembly manufactured for this purpose.

3. Type IC rated, certified under ASTM E283 to have no more than 2.0 cfm air movement from the conditioned space to the ceiling cavity. The lighting fixture shall be tested at 75 Pascals or 1.57 lbs/ft² pressure difference and have a label attached, showing compliance.

[Statutory Authority: RCW 19.27A.025, 19.27A.045, 02-01-112, § 51-11-0502, filed 12/18/01, effective 7/1/02; 01-03-010, § 51-11-0502, filed 1/5/01, effective 7/1/01; 98-03-003, § 51-11-0502, filed 1/8/98, effective 7/1/98. Statutory Authority: Chapters 19.27 and 19.27A RCW and 1994 c 226, 95-01-126, § 51-11-0502, filed 12/21/94, effective 6/30/95. Statutory Authority: Chapters 19.27, 19.27A and 34.05 RCW, 94-05-059, § 51-11-0502, filed 2/10/94, effective 4/1/94. Statutory Authority: Chapter 19.27A RCW, 92-01-140, § 51-11-0502, filed 12/19/91, effective 7/1/92. Statutory Authority: RCW 19.27A.020 and 1990 c 2, 91-01-112, § 51-11-0502, filed 12/19/90, effective 7/1/91.]

Reviser's note: The brackets and enclosed material in the text of the above section occurred in the copy filed by the agency.

WAC 51-11-0503 Building mechanical systems.

503.1 General: This section covers the determination of design requirements, system and component performance, control requirements, insulating systems and duct sealing. For all other duct construction requirements, refer to the State Mechanical Code (chapter 51-42 WAC).

503.2 Calculations of Heating and Cooling Loads, and System Sizing Limits: The design parameters specified in Chapter 3 shall apply for all computations.

503.2.1 Calculation Procedures: Heating and cooling design loads for the purpose of sizing HVAC systems are required and shall be calculated in accordance with accepted engineering practice, including infiltration and ventilation.

503.2.2 Space Heating and Space Cooling System Sizing Limits: Building mechanical systems for all buildings which provide space heating and/or space cooling shall be sized no greater than two hundred percent (200%) of the heating and cooling design loads as calculated above.

EXCEPTIONS: The following limited exemptions from the sizing limit shall be allowed; however, in all cases heating and/or cooling design load calculations shall be submitted.

1. For equipment which provides both heating and cooling in one package unit, including heat pumps with electric heating and cooling and gas-pack units with gas heating and electric cooling, compliance need only be demonstrated for either the space heating or space cooling system size.

2. Natural gas- or oil-fired space heating equipment whose total rated space heating output in any one dwelling unit is

a. 40,000 Btu/h or less is exempt from the sizing limit,

b. larger than 40,000 Btu/h may exceed the two hundred (200%) percent sizing limit provided that the installed equipment has an annual fuel utilization efficiency (AFUE) of not less than ninety (90%) percent.

3. Stand-by equipment may be installed if controls and other devices are provided which allow redundant equipment to operate only when the primary equipment is not operating.

503.3 Simultaneous Heating and Cooling: Systems and equipment that provide simultaneous heating and cooling shall comply with the requirements in, as appropriate, Section 1422 or Section 1435.

[Title 51 WAC—p. 42]

503.4 HVAC Equipment Performance Requirements: All heating equipment shall meet the requirements of the 1987 National Appliance Energy Conservation Act (NAECA) and be so labeled. Equipment shall also comply with Section 1411.

503.5 Reserved.

503.6 Balancing: The HVAC system design shall provide a means for balancing air and water systems. Balancing the system shall include, but not be limited to, dampers, temperature and pressure test connections and balancing valves.

503.7 Cooling with Outdoor Air (Economizer Cycle): Systems and equipment that provide mechanical cooling shall comply with Section 1413 and, as appropriate, Section 1423 or 1433.

503.8 Controls:

503.8.1 Temperature Control: Each system shall be provided with at least one adjustable thermostat for the regulation of temperature. Each thermostat shall be capable of being set by adjustment or selection of sensors as follows:

503.8.1.1: When used to control heating only: Fifty-five degrees to seventy-five degrees F.

503.8.1.2: When used to control cooling only: Seventy degrees to eighty-five degrees F.

503.8.1.3: When used to control both heating and cooling, it shall be capable of being set from fifty-five degrees to eighty-five degrees F and shall be capable of operating the system heating and cooling in sequence. The thermostat and/or control system shall have an adjustable deadband of not less than ten degrees F.

503.8.2 Humidity Control: If a system is equipped with a means for adding moisture to maintain specific selected relative humidities in space or zones, a humidistat shall be provided. Humidistats shall be capable of being set to prevent new energy from being used to produce space-relative humidity above thirty percent.

EXCEPTION: Special uses requiring different relative humidities may be permitted when approved by the building official.

503.8.3 Zoning for Temperature Control:

503.8.3.1 One- and Two-Family Dwellings: At least one thermostat for regulation of space temperature shall be provided for each separate system. In addition, a readily accessible manual or automatic means shall be provided to partially restrict or shut off the heating and/or cooling input to each zone or floor.

503.8.3.2 Multifamily Dwellings: For multifamily dwellings, each individual dwelling unit shall have at least one thermostat for regulation of space temperature. A readily accessible manual or automatic means shall be provided to partially restrict or shut off the heating and/or cooling input to each room. Spaces other than living units shall meet the requirements of 503.8.3.3.

503.8.3.3 Reserved.

503.8.3.4 Control Setback and Shut-off:

Residential Occupancy Groups. One- and Two-Family and Multifamily dwellings—The thermostat required in section 503.8.3.1 or section 503.8.3.2, or an alternate means such as a switch or clock, shall provide a readily accessible, manual or automatic means for reducing the energy required for heating and cooling during the periods of nonuse or reduced need, such as, but not limited to unoccupied periods and sleeping hours. Lowering thermostat set points to reduce energy consumption of heating systems shall not cause energy to be expended to reach the reduced setting.

503.8.3.5 Heat Pump Controls: Programmable thermostats are required for all heat pump systems. The cut-on temperature for the compression heating shall be higher than the cut-on temperature for the supplementary heat, and the cut-off temperature for the compression heating shall be higher than the cut-off temperature for the supplementary heat. Heat pump thermostats will be capable of providing at least two programmable setback periods per day. The automatic setback thermostat shall have the capability of limiting the use of supplemental heat during the warm-up period.

503.9 Air Handling Duct System Insulation: Ducts, plenums and enclosures installed in or on buildings shall be thermally insulated per Table 5-11.

- EXCEPTIONS: Duct insulation (except where required to prevent condensation) is not required in any of the following cases:
1. When the heat gain or loss of the ducts, without insulation, will not increase the energy requirements of the building.
 2. Within the HVAC equipment.
 3. Exhaust air ducts.
 4. Supply or return air ducts installed in unvented crawl spaces with insulated walls, basements, or cellars in one-and two-family dwellings.

503.10 Ducts.

503.10.1 Leakage Testing: High-pressure and medium-pressure ducts shall be leak tested in accordance with the 1985 Edition of the SMACNA HVAC Air Duct Leakage Test Manual with the rate of air leakage not to exceed the maximum rate specified in that standard.

503.10.2 Seams and Joints: All low-pressure supply and return duct transverse joints, and enclosed stud bays or joist cavities/space used to transport air, shall be securely fastened and sealed with welds, gaskets, mastics (adhesives), or mastic-plus-embedded-fabric systems installed in accordance with the manufacturer's installation instructions.

- EXCEPTIONS:
1. Ducts or building cavities used for air distribution that are located entirely within the conditioned space of the building are exempt from this section.
 2. UL 181A listed tapes used with listed rigid fibrous glass ducts may be used as the primary sealant, when installed in accordance with the listing.
 3. UL 181B listed tapes used with listed flexible air ducts may be used as the primary sealant, when installed in accordance with the listing.
 4. Where enclosed stud bays or joist cavities/spaces are used to transport air sealing may be accomplished using drywall, drywall tape plus joint compound.
 5. Tapes installed in accordance with the manufacturer's installation instructions, providing detailed information specific to application on ducts, including

approved duct materials and required duct surface cleaning.

503.10.3 Dampers: Requirements for Automatic or manual dampers are found in the Washington State Ventilation and Indoor Air Quality Code.

503.11 Pipe Insulation: All piping shall be thermally insulated in accordance with Table 5-12.

EXCEPTION: Piping installed within unitary HVAC equipment.

Cold water pipes outside the conditioned space shall be insulated in accordance with the Washington State Plumbing Code (chapter 51-46 WAC).

[Statutory Authority: RCW 19.27A.020, 19.27A.045. 02-24-076, § 51-11-0503, filed 12/4/02, effective 5/1/03. Statutory Authority: RCW 19.27A.025, 19.27A.045. 02-01-112, § 51-11-0503, filed 12/18/01, effective 7/1/02; 01-03-010, § 51-11-0503, filed 1/5/01, effective 7/1/01. Statutory Authority: RCW 19.27A.020, 19.27A.045, and 19.27.020. 98-24-075, § 51-11-0503, filed 12/1/98, effective 7/1/99. Statutory Authority: RCW 19.27A.025 and 19.27A.045. 98-03-003, § 51-11-0503, filed 1/8/98, effective 7/1/98. Statutory Authority: RCW 19.27A.025. 93-21-052, § 51-11-0503, filed 10/18/93, effective 4/1/94. Statutory Authority: Chapter 19.27A RCW. 92-01-140, § 51-11-0503, filed 12/19/91, effective 7/1/92. Statutory Authority: RCW 19.27A.020 and 1990 c 2. 91-01-112, § 51-11-0503, filed 12/19/90, effective 7/1/91.]

WAC 51-11-0504 Service water heating.

504.1 Scope: The purpose of this section is to provide criteria for design and equipment selection that will produce energy savings when applied to service water heating.

504.2 Water Heaters, Storage Tanks and Boilers:

504.2.1 Performance Efficiency: All Storage water heaters shall meet the requirements of the 1987 National Appliance Energy Conservation Act and be so labeled. All electric water heaters in unheated spaces or on concrete floors shall be placed on an incompressible, insulated surface with a minimum thermal resistance of R-10.

For combination space and service water heaters with a principal function of providing space heat, the Combined Annual Efficiency (CAE) may be calculated by using ASHRAE Standard 124-1991. Storage water heaters used in combination space heat and water heat applications shall have either an Energy Factor (EF) or a Combined Annual Efficiency (CAE) of not less than the following:

	Energy Factor (EF)	Combined Annual Efficiency (CAE)
<50 gallon storage	0.58	0.71
50 to 70 gallon storage	0.57	0.71
>70 gallon storage	0.55	0.70

504.2.2 Insulation: Heat loss from unfired hot-water storage tanks shall be limited to a maximum of 9.6 Btu/hr/ft² of external tank surface area. The design ambient temperature shall be no higher than sixty-five degrees F.

504.2.3 Combination Service Water Heating/Space Heating Boilers: Service water heating equipment shall not be dependent on year round operation of space heating boilers.

EXCEPTIONS:

1. Systems with service/space heating boilers having a standby loss Btu/h less than:
 $(13.3 \text{ pmd} + 400)/n$
determined by the fixture count method where:
pmd = probably maximum demand in gallons/hour as determined in accordance with Chapter 37 of Standard RS-11.
n = fraction of year when outdoor daily mean temperature exceeds 64.9° F.
The standby loss is to be determined for a test period of twenty-four-hour duration while maintaining a boiler water temperature of ninety degrees F above an ambient of sixty degrees F and a five foot stack on appliance.
2. For systems where the use of a single heating unit will lead to energy savings, such unit shall be utilized.

504.3 Automatic Controls: Service water heating systems shall be equipped with automatic temperature controls capable of adjustment from the lowest to the highest acceptable temperature settings for the intended use. Temperature setting range shall be set to one hundred twenty degrees F or forty-nine degrees C.

504.4 Shutdown: A separate switch shall be provided to permit turning off the energy supplied to electric service water heating systems. A separate valve shall be provided to permit turning off the energy supplied to the main burner(s) of all other types of service water heater systems.

504.5 Swimming Pools:

504.5.1: All pool heaters shall be equipped with readily accessible ON/OFF switch to allow shutting off the operation of the heater without adjusting the thermostat setting. Controls shall be provided to allow the water temperature to be regulated from the maximum design temperature down to sixty-five degrees F.

504.5.2 Pool Covers: Heated swimming pools shall be equipped with a pool cover, approved by the building official.

WAC 51-11-0525 Equation 1—Group R Occupancy.

EQUATION 1—GROUP R OCCUPANCY TARGET UA

$$UA_T = U_W A_W + U_{BGW} A_{BGW} + U_{VG} A_{VG} + U_{OG} A_{OG} + U_F A_F + U_{RC} A_{RC} + U_{CC} A_{CC} + U_D A_D + F_s P_s$$

Where:

- UA_T = the target combined thermal transmittance of the gross exterior wall, floor and roof/ceiling assembly area.
- U_W = the thermal transmittance value of the opaque above grade wall area found in Table 5-1.
- A_W = opaque above grade wall area.
- U_{BGW} = the thermal transmittance value of the below grade opaque wall area found in Table 5-1.
- A_{BGW} = opaque below grade wall area.
- U_{VG} = the thermal transmittance value of the vertical glazing area found in Table 5-1.
- A_{VG} = 15% of the total floor area of the conditioned space minus A_{OG} .
- U_{OG} = the thermal transmittance value of the overhead glazing area found in Table 5-1 (see Table 5-1 footnote 2).
- A_{OG} = overhead glazing area (if the proposed A_{OG} exceeds 15 percent, the target A_{OG} shall be 15 percent of the total floor area of the conditioned space).
- U_F = the thermal transmittance value of the floor area found in Table 5-1.
- A_F = floor area over unconditioned space.
- U_{RC} = the thermal transmittance value of the roof/ceiling area found in Table 5-1.

504.6 Pump Operation: Circulating hot water systems shall be controlled so that the circulation pump(s) can be conveniently turned off, automatically or manually, when the hot water system is not in operation.

504.7 Pipe Insulation: Piping shall be thermally insulated in accordance with section 503.11.

504.8 Conservation of Hot Water:

504.8.1 Showers and Lavatories: Showers and lavatories used for other than safety reasons shall be equipped with flow control devices or specially manufactured showerheads or aerators to limit the total water flow rate as set forth in chapter 51-26 WAC, as measured with both hot and cold faucets turned on to their maximum flow.

[Statutory Authority: RCW 19.27A.025, 19.27A.045. 01-03-010, § 51-11-0504, filed 1/5/01, effective 7/1/01; 98-03-003, § 51-11-0504, filed 1/8/98, effective 7/1/98. Statutory Authority: Chapter 19.27A RCW. 92-01-140, § 51-11-0504, filed 12/19/91, effective 7/1/92. Statutory Authority: RCW 19.27A.020 and 1990 c 2. 91-01-112, § 51-11-0504, filed 12/19/90, effective 7/1/91.]

WAC 51-11-0505 Lighting.

505.1 Lighting Controls: Hotel and motel guest rooms and guest suites shall have a master control device at the main room entry that controls all permanently installed luminaires and switched receptacles.

505.2 Lighting Power: Lighting shall comply with the Prescriptive Lighting Option in Section 1520 or the Lighting Power Allowance Option in Section 1530.

EXCEPTIONS:

1. Group R-3 Occupancy and the dwelling unit portions of Group R-1 Occupancy.
2. Lighting exempted by Section 1512.

[Statutory Authority: RCW 19.27A.025, 19.27A.045. 01-03-010, § 51-11-0505, filed 1/5/01, effective 7/1/01. Statutory Authority: RCW 19.27A.025. 93-21-052, § 51-11-0505, filed 10/18/93, effective 4/1/94. Statutory Authority: Chapter 19.27A RCW. 92-01-140, § 51-11-0505, filed 12/19/91, effective 7/1/92. Statutory Authority: RCW 19.27A.020 and 1990 c 2. 91-01-112, § 51-11-0505, filed 12/19/90, effective 7/1/91.]

- A_{RC} = roof/ceiling area.
- U_{CC} = the thermal transmittance value of the cathedral ceiling area found in Table 5-1.
- A_{CC} = cathedral ceiling area.
- U_D = the thermal transmittance value of the opaque door area found in Table 5-1.
- A_D = opaque door area.
- F_s = concrete slab component F-factor found in Table 5-1.
- P_s = lineal ft. of concrete slab perimeter.

[Statutory Authority: RCW 19.27A.025 and 19.27A.045. 98-03-003, § 51-11-0525, filed 1/8/98, effective 7/1/98. Statutory Authority: Chapters 19.27, 19.27A and 34.05 RCW. 94-05-059, § 51-11-0525, filed 2/10/94, effective 4/1/94. Statutory Authority: Chapter 19.27A RCW. 92-01-140, § 51-11-0525, filed 12/19/91, effective 7/1/92.]

- r_o = .17 for all exterior surfaces.
- r_i = inside air film resistance.
- r_i = 0.61 for interior horizontal surfaces, heat flow up.
- r_i = 0.92 for interior horizontal surfaces, heat flow down.
- r_i = 0.68 for interior vertical surfaces.
- $R = \frac{1}{C} = \frac{X}{K}$ = measure of the resistance to the passage of heat for each element.
- C = conductance, the heat flow through a specific material of specific thickness.
- K = insulation value of a material per inch.
- X = the thickness of the material in inches.

WAC 51-11-0526 Equation 2—All occupancies.

EQUATION 2 — ALL OCCUPANCIES

$$U = \frac{1}{r_o + R_1 + R_2 \dots r_i}$$

Where:

- U = the thermal transmittance of the assembly.
- r_o = outside air film resistance.

[Statutory Authority: Chapter 19.27A RCW. 92-01-140, § 51-11-0526, filed 12/19/91, effective 7/1/92.]

WAC 51-11-0527 Equation 3—Group R Occupancy.

**EQUATION 3 — GROUP R OCCUPANCY
PROPOSED UA**

$$UA = U_w A_w + U_{BGW} A_{BGW} + U_{VG} A_{VG} + U_{OG} A_{OG} + U_F A_F + U_{RC} A_{RC} + U_{CC} A_{CC} + U_D A_D + F_s P_s$$

Where:

- UA = the combined thermal transmittance of the gross exterior wall, floor and roof/ceiling assembly area.
- U_w = the thermal transmittance of the opaque wall area.
- A_w = opaque wall area.
- U_{BGW} = the thermal transmittance value of the below grade opaque wall area.
- A_{BGW} = opaque below grade wall area.
- U_{VG} = the thermal transmittance value of the vertical glazing area.
- A_{VG} = vertical glazing area, including windows in exterior doors.
- U_{OG} = the thermal transmittance value of the overhead glazing area.
- A_{OG} = overhead glazing area.
- U_F = the thermal transmittance of the floor area.
- A_F = floor area over unconditioned space.
- U_{RC} = the thermal transmittance of the roof/ceiling area.
- A_{RC} = roof/ceiling area.
- U_{CC} = the thermal transmittance of the cathedral ceiling area.
- A_{CC} = cathedral ceiling area.
- U_D = the thermal transmittance value of the opaque door area.
- A_D = opaque door area.
- F_s = concrete slab component F-factor.
- P_s = lineal ft. of concrete slab perimeter.

NOTE : Where more than one type of wall, window, roof/ceiling, door and skylight is used, the U and A terms for those items shall be expanded into sub-elements as:

$$U_{w1} A_{w1} + U_{w2} A_{w2} + U_{w3} A_{w3} + \dots \text{etc.}$$

[Statutory Authority: RCW 19.27A.025 and 19.27A.045. 98-03-003, § 51-11-0527, filed 1/8/98, effective 7/1/98. Statutory Authority: Chapters 19.27, 19.27A and 34.05 RCW. 94-05-059, § 51-11-0527, filed 2/10/94, effective 4/1/94. Statutory Authority: Chapter 19.27A RCW. 92-01-140, § 51-11-0527, filed 12/19/91, effective 7/1/92.]

WAC 51-11-0528 Equation 4—Reserved.

[Statutory Authority: RCW 19.27A.025, 93-21-052, § 51-11-0528, filed 10/18/93, effective 4/1/94. Statutory Authority: Chapter 19.27A RCW. 92-01-140, § 51-11-0528, filed 12/19/91, effective 7/1/92.]

WAC 51-11-0529 Equation 5—Reserved.

[Statutory Authority: RCW 19.27A.025, 93-21-052, § 51-11-0529, filed 10/18/93, effective 4/1/94. Statutory Authority: Chapter 19.27A RCW. 92-01-140, § 51-11-0529, filed 12/19/91, effective 7/1/92.]

WAC 51-11-0530 Table 5-1.

**TABLE 5-1
TARGET COMPONENT VALUES FOR GROUP R OCCUPANCY**

Component	Climate Zone	
	1	2
Glazing % Floor Area	15%	15%
Vertical Glazing U-Factor	U = 0.400	U = 0.400
Overhead Glazing U-Factor	U = 0.58	U = 0.58
Doors	U = 0.200 (R-5)	U = 0.200 (R-5)
Ceilings		
Attic	U = 0.031 (R-38)	U = 0.031 (R-38)
Single Rafter/ Joist Vaulted	U = 0.034 (R-30)	U = 0.034 (R-30)
Walls ²		
Space Heat Type: Electric Resistance	U = 0.058 (R-19A)	U = 0.044 (R-19A + R-5)
Other	U = 0.062 ¹ (R-19)	U = 0.062 ¹ (R-19)
Floors	U = 0.029 (R-30)	U = 0.029 (R-30)
Slab on Grade Slab R-Value	F = 0.54 (R-10)	F = 0.54 (R-10)
Below Grade Interior		
Wall R-Value	R-19	R-19
2' Depth: Walls	U = 0.043	U = 0.043
Slab	F = 0.69	F = 0.69
3.5' Depth: Walls	U = 0.041	U = 0.041
Slab	F = 0.64	F = 0.64
7' Depth: Walls	U = 0.037	U = 0.037
Slab	F = 0.57	F = 0.57
Below Grade Exterior		
Wall R-Value	R-10	R-12
2' Depth: Walls	U = 0.070	U = 0.061
Slab	F = 0.60	F = 0.60
3.5' Depth: Walls	U = 0.064	U = 0.057
Slab	F = 0.57	F = 0.57
7' Depth: Walls	U = 0.056	U = 0.050
Slab	F = 0.42	F = 0.42

1. Log and Solid Timber walls that have a minimum average thickness of 3.5" are exempt from wall target UA and proposed UA calculations.
2. "A" means advanced framing. For more information, see Section 1005.2.

[Statutory Authority: RCW 19.27A.025, 19.27A.045, 02-01-112, § 51-11-0530, filed 12/18/01, effective 7/1/02; 01-03-010, § 51-11-0530, filed 1/5/01, effective 7/1/01; 98-03-003, § 51-11-0530, filed 1/8/98, effective 7/1/98. Statutory Authority: Chapters 19.27 and 19.27A RCW and 1994 c 226, 95-01-126, § 51-11-0530, filed 12/21/94, effective 6/30/95. Statutory Authority: Chapter 19.27A RCW. 92-01-140, § 51-11-0530, filed 12/19/91, effective 7/1/92.]

WAC 51-11-0531 Table 5-2—Reserved.

[Statutory Authority: RCW 19.27A.025, 93-21-052, § 51-11-0531, filed 10/18/93, effective 4/1/94. Statutory Authority: Chapter 19.27A RCW. 92-01-140, § 51-11-0531, filed 12/19/91, effective 7/1/92.]

[Title 51 WAC—p. 46]

WAC 51-11-0532 Table 5-3—Reserved.

[Statutory Authority: RCW 19.27A.025, 93-21-052, § 51-11-0532, filed 10/18/93, effective 4/1/94. Statutory Authority: Chapter 19.27A RCW. 92-01-140, § 51-11-0532, filed 12/19/91, effective 7/1/92.]

WAC 51-11-0533 Table 5-4—Reserved.

[Statutory Authority: RCW 19.27A.025, 19.27A.045, 02-01-112, § 51-11-0533, filed 12/18/01, effective 7/1/02. Statutory Authority: Chapter 19.27A RCW. 92-01-140, § 51-11-0533, filed 12/19/91, effective 7/1/92.]

WAC 51-11-0534 Table 5-5—Reserved.

[Statutory Authority: RCW 19.27A.025, 19.27A.045, 02-01-112, § 51-11-0534, filed 12/18/01, effective 7/1/02. Statutory Authority: Chapter 19.27A RCW. 92-01-140, § 51-11-0534, filed 12/19/91, effective 7/1/92.]

WAC 51-11-0535 Table 5-6—Reserved.

[Statutory Authority: RCW 19.27A.025, 19.27A.045, 02-01-112, § 51-11-0535, filed 12/18/01, effective 7/1/02. Statutory Authority: Chapter 19.27A RCW. 92-01-140, § 51-11-0535, filed 12/19/91, effective 7/1/92.]

WAC 51-11-0536 Table 5-7—Reserved.

[Statutory Authority: RCW 19.27A.025, 19.27A.045, 02-01-112, § 51-11-0536, filed 12/18/01, effective 7/1/02. Statutory Authority: Chapter 19.27A RCW. 92-01-140, § 51-11-0536, filed 12/19/91, effective 7/1/92.]

WAC 51-11-0537 Table 5-8—Reserved.

[Statutory Authority: RCW 19.27A.025, 19.27A.045, 02-01-112, § 51-11-0537, filed 12/18/01, effective 7/1/02. Statutory Authority: Chapter 19.27A RCW. 92-01-140, § 51-11-0537, filed 12/19/91, effective 7/1/92.]

WAC 51-11-0538 Table 5-9—Reserved.

[Statutory Authority: RCW 19.27A.025, 93-21-052, § 51-11-0538, filed 10/18/93, effective 4/1/94. Statutory Authority: Chapter 19.27A RCW. 92-01-140, § 51-11-0538, filed 12/19/91, effective 7/1/92.]

WAC 51-11-0539 Table 5-10—Reserved.

[Statutory Authority: RCW 19.27A.025, 93-21-052, § 51-11-0539, filed 10/18/93, effective 4/1/94. Statutory Authority: Chapter 19.27A RCW. 92-01-140, § 51-11-0539, filed 12/19/91, effective 7/1/92.]

WAC 51-11-0540 Table 5-11.

**TABLE 5-11
INSULATION OF DUCTS**

DUCT LOCATION	CLIMATE ZONE	GROUP R OCCUPANCY
		HEATING OR COOLING DUCTS
On roof or on exterior of building	I	E and W
	II	D and W
Attic, garage, crawl space, in walls ¹ , in floor/ceiling ¹	I	E
	II	E
Within the conditioned space or in heated basement		None Required
In cement slab or in ground		B

Note: Where ducts are used for both heating and cooling, the minimum insulation shall be as required for the most restrictive condition.

- ¹ Insulation may be omitted on that portion of a duct which is located within a wall or floor-ceiling space where both sides of this space are exposed to conditioned air and where this space is not ventilated or otherwise exposed to unconditioned air.
- ² Vapor barriers shall be installed on conditioned air supply ducts in geographic areas where the average of the July, August, and September mean dewpoint temperature exceeds 60°F.

INSULATION TYPES: Minimum densities and out-of-package thickness.

- A. 0.5-inch 1.5 to 2 lb/cu. ft. duct liner, mineral or glass fiber blanket or equivalent to provide an installed total thermal resistance of at least R-2.
- B. 2-inch 0.60 lb/cu. ft. mineral or glass fiber blanket 1.5-inch 1.5 to 2 lb/cu. ft. duct liner, mineral or glass fiber blanket. 1.5-inch 3 to 7 lb/cu. ft. mineral or glass fiber

- board or equivalent to provide an installed total thermal resistance of at least R-5.
- C. 3-inch 0.60 lb/cu. ft. mineral or glass fiber blanket 2-inch 1.5 to 2 lb/cu. ft. duct liner, mineral or glass fiber blanket. 2-inch 3 to 7 lb/cu. ft. mineral or glass fiber board or equivalent to provide an installed total thermal resistance of at least R-7.
- D. 4-inch 0.60 lb/cu. ft. mineral or glass fiber blanket 3-inch 1.5 to 2 lb/cu. ft. duct liner, mineral or glass fiber blanket. 3-inch 3 to 7 lb/cu. ft. mineral or glass fiber board or equivalent to provide an installed total thermal resistance of at least R-10.
- E. 3.5 inch 0.60 lb/cu. ft. mineral or glass fiber blanket, 2.5 inch 1.5 to 2 lb/cu. ft. duct liner, mineral or glass fiberboard or equivalent to provide an installed total thermal resistance of at least R-8.
- V. Vapor barrier, with perm rating not greater than 0.5 perm, all joints sealed.
- W. Approved weatherproof barrier.

[Statutory Authority: RCW 19.27A.025, 93-21-052, § 51-11-0540, filed 10/18/93, effective 4/1/94. Statutory Authority: Chapter 19.27A RCW. 92-01-140, § 51-11-0540, filed 12/19/91, effective 7/1/92.]

WAC 51-11-0541 Table 5-12.

TABLE 5-12
MINIMUM PIPE INSULATION REQUIREMENTS

Fluid Design Operating Temp. Range, °F	Insulation Conductivity		Normal Pipe Diameter (in.)					
	Conductivity Range Btu • in./(h • ft ² • °F)	Mean Rating Temp. °F	Runouts ² up to 2	1 and less	> 1 to 2	> 2 to 4	> 4 to 6	> 6
Heating systems (Steam, Steam Condensate and Hot water)			Nominal Insulation Thickness					
Above 350	0.32-0.34	250	1.5	2.5	2.5	3.0	3.5	3.5
251-350	0.29-0.31	200	1.5	2.0	2.5	2.5	3.5	3.5
201-250	0.27-0.30	150	1.0	1.5	1.5	2.0	2.0	3.5
141-200	0.25-0.29	125	0.5	1.5	1.5	1.5	1.5	1.5
105-140	0.24-0.28	100	0.5	1.0	1.0	1.0	1.5	1.5
Domestic and Service Hot Water Systems								
105 and Greater	0.24-0.28	100	0.5	1.0	1.0	1.5	1.5	1.5
Cooling Systems (Chilled Water, Brine and Refrigerant)								
40-55	0.23-0.27	75	0.5	0.5	0.75	1.0	1.0	1.0
Below 40	0.23-0.27	75	1.0	1.0	1.5	1.5	1.5	1.5

- 1. Alternative Insulation Types. Insulation thicknesses in Table 5-12 are based on insulation with thermal conductivities within the range listed in Table 5-12 for each fluid operating temperature range, rated in accordance with ASTM C 335-84 at the mean temperature listed in the table. For insulation that has a conductivity outside the range shown in Table 5-12 for the applicable fluid operating temperature range at the mean rating temperature shown (when rounded to the nearest 0.01 Btu • in./(h • ft² • °F)), the minimum thickness shall be determined in accordance with the following equation:

$$T = PR[(1 + t/PR)^{K/k} - 1]$$

Where

- T = Minimum insulation thickness for material with conductivity K, inches.
- PR = Pipe actual outside radius, inches
- t = Insulation thickness from Table 5-12, inches
- K = Conductivity of alternate material at the mean rating temperature indicated in Table 5-12 for the applicable fluid temperature range, Btu • in./(h • ft² • °F)
- k = The lower value of the conductivity range listed in Table 5-12 for the applicable fluid temperature range, Btu • in./(h • ft² • °F)

- 2. Runouts to individual terminal units not exceeding 12 ft. in length.

[Statutory Authority: RCW 19.27A.025 and 19.27A.045, 98-03-003, § 51-11-0541, filed 1/8/98, effective 7/1/98. Statutory Authority: Chapter 19.27A RCW. 92-01-140, § 51-11-0541, filed 12/19/91, effective 7/1/92.]

Reviser's note: The brackets and enclosed material in the text of the above section occurred in the copy filed by the agency.

WAC 51-11-0542 Table 5-13—Reserved.

[Statutory Authority: RCW 19.27A.025, 93-21-052, § 51-11-0542, filed 10/18/93, effective 4/1/94. Statutory Authority: Chapter 19.27A RCW. 92-01-140, § 51-11-0542, filed 12/19/91, effective 7/1/92.]

WAC 51-11-0600 Chapter 6 building design by prescriptive requirements approach.

[Statutory Authority: RCW 19.27A.020 and 1990 c 2. 91-06-065, § 51-11-0600, filed 3/1/91, effective 7/1/91.]

WAC 51-11-0601 Scope.

601.1 General: This chapter establishes design criteria in terms of prescribed requirements for building construction.

The provisions of this chapter are applicable to all Group R Occupancies. Occupancies shall comply with all the requirements of Chapter 5 except for the modifications herein specified.

For wood frame assemblies, the building envelope requirements of this chapter may be met by installing one of the prescriptive packages in Table 6-1 or 6-2. Installed components shall meet the requirements of section 602. Compliance with nominal R-Values shall be demonstrated for the thermal resistance of the added insulation in framing cavities and/or insulated sheathing only and shall not include the thermal transmittance of other building materials or air films, but shall permit interruption by occasional framing members. Other than wood frame assemblies with continuous insulation uninterrupted by framing shall also be allowed to comply with nominal R-values.

For metal frame assemblies, compliance shall be demonstrated in accordance with Chapter 4 or Chapter 5 based on the assemblies in Chapter 10. Compliance with nominal R-values is not allowed, unless the full nominal R-value of the insulation is installed either inside or outside of the framing and is uninterrupted by framing.

EXCEPTION: Group R-1 occupancy buildings may use a maximum area weighted average U-factor for components not exceeding those prescribed in Paths III and V in Table 6-1 or Paths IV and VI in Table 6-2.

[Statutory Authority: RCW 19.27A.020, 19.27A.045, 02-24-076, § 51-11-0601, filed 12/4/02, effective 5/1/03. Statutory Authority: RCW 19.27A.025, 19.27A.045, 02-01-112, § 51-11-0601, filed 12/18/01, effective 7/1/02; 01-03-010, § 51-11-0601, filed 1/5/01, effective 7/1/01. Statutory Authority: Chapters 19.27, 19.27A and 34.05 RCW. 94-05-059, § 51-11-0601, filed 2/10/94, effective 4/1/94. Statutory Authority: RCW 19.27A.020 and 1990 c 2. 91-01-112, § 51-11-0601, filed 12/19/90, effective 7/1/91.]

WAC 51-11-0602 Building envelope requirements for Group R Occupancy.

602.1 Roof/Ceiling: Ceilings below vented attics and single-rafter, joist-vaulted ceilings shall be insulated to not less than the nominal R-value specified for ceilings in Table 6-1 or 6-2 as applicable.

602.2 Exterior Walls Both Above and Below Grade: Above grade exterior walls shall be insulated to not less than the nominal R-value specified in Table 6-1 or 6-2 as applicable. The following walls should be considered to meet R-21 without additional documentation:

1. 2 x 6 framed and insulated with R-21 fiberglass batts.
2. 2 x 4 framed and insulated with R-15 fiberglass batts plus R-4.0 foam sheathing.
3. 2 x 4 framed and insulated with R-13 fiberglass batts plus R-5.0 foam sheathing.

602.3 Exterior Walls (Below Grade): Below grade exterior walls surrounding conditioned space shall be insulated to not less than the nominal R-value specified for below grade walls in Table 6-1 or 6-2 as applicable.

602.4 Slab-on-grade Floors: Slab-on-grade floors shall be insulated along their perimeter to not less than the nominal R-values specified for slab-on-grade floors in Table 6-1 or 6-2 as applicable. Slab insulation shall be installed in compliance with section 502.1.4.8. See Chapter 5, section 502.1.4.9, for additional requirements for radiant slab heating.

602.5 Floors Over Unconditioned Space: Floors over unconditioned spaces, such as vented crawl spaces, unconditioned basements, and parking garages shall be insulated to not less than the nominal R-value shown for floors over unconditioned spaces, in Table 6-1 or 6-2.

602.6 Exterior Doors: Doors shall comply with Sections 602.6.1 and 602.6.2.

- EXCEPTIONS:**
1. Doors whose area and U-factor are included in the calculations for compliance with the requirements for glazing in section 602.7 shall be exempt from the door U-factor requirements prescribed in Table 6-1 or 6-2.
 2. One unlabeled or untested exterior swinging door with the maximum area of 24 square feet may be installed per unit for ornamental, security or architectural purposes. Products using this exception shall not be included in either the U-factor or glazing area calculation requirements.

602.6.1 Exterior Door Area: For half-lite and full-lite doors, the glazing area shall be included in calculating the allowed total glazing area in Section 602.7.1. Single glazing used for ornamental, security or architectural purposes shall be calculated using the exception to Section 602.7.2.

602.6.2 Exterior Door U-Factor: Doors, including fire doors, shall have a maximum area weighted average U-factor not exceeding that prescribed in Table 6-1 or 6-2.

602.7 Glazing:

602.7.1 Glazing Area: The total glazing area as defined in Chapter 2 shall not exceed the percentage of gross conditioned floor area specified in Table 6-1 or 6-2. This area shall also include any glazing in doors.

602.7.2 Glazing U-Factor: The total glazing area as defined in Chapter 2 shall have an area weighted average U-factor not to exceed that specified in Table 6-1 or 6-2. U-factors for glazing shall be determined in accordance with section 502.1.5. These areas and U-factors shall also include any doors using the exception of section 602.6.

If the U-factors for all vertical and overhead glazing products are below the appropriate U-factor specified, then no calculations are required. If compliance is to be achieved through an area weighted calculation, then the areas and U-

factors shall be included in the plans submitted with a building permit application.

EXCEPTION: Single glazing for ornamental, security, or architectural purposes and double glazed garden windows with a wood or vinyl frame shall be exempt from the U-factor calculations but shall have its area tripled and shall be included in the percentage of the total glazing area as allowed for in Table 6-1 or 6-2. The maximum area (before tripling) allowed for the total of all single glazing and garden windows is one percent of the floor area.

602.8 Air Leakage For Group R Occupancy: The minimum air leakage control measures shall be as specified in section 502.4 as applicable.

[Statutory Authority: RCW 19.27A.020, 19.27A.045. 02-24-076, § 51-11-0602, filed 12/4/02, effective 5/1/03. Statutory Authority: RCW 19.27A.025, 19.27A.045. 02-01-112, § 51-11-0602, filed 12/18/01, effective 7/1/02; 98-03-003, § 51-11-0602, filed 1/8/98, effective 7/1/98. Statutory Authority: Chapters 19.27, 19.27A and 34.05 RCW. 94-05-059, § 51-11-0602, filed 2/10/94, effective 4/1/94. Statutory Authority: RCW 19.27A.020 and 1990 c 2. 91-01-112, § 51-11-0602, filed 12/19/90, effective 7/1/91.]

WAC 51-11-0603 Building mechanical systems for Group R Occupancy.

603.1: Group R Occupancies that are space heated by air-to-air, ground-to-air, or water-to-air heat pumps shall

WAC 51-11-0625 Table 6-1.

**TABLE 6-1
PRESCRIPTIVE REQUIREMENTS^{0,1} FOR GROUP R OCCUPANCY
CLIMATE ZONE 1**

Option	Glazing Area ¹⁰ : % of Floor	Glazing U-Factor		Door ⁹ U-Factor	Ceiling ²	Vaulted Ceiling ³	Wall ¹² Above Grade	Wall• int ⁴ Below Grade	Wall• ext ⁴ Below Grade	Floor ⁵	Slab ⁶ on Grade
		Vertical	Overhead ¹¹								
I.	12%	0.35	0.58	0.20	R-38	R-30	R-15	R-15	R-10	R-30	R-10
II.*	15%	0.40	0.58	0.20	R-38	R-30	R-21	R-21	R-10	R-30	R-10
III.	25% Group R-1 Occupancy only	0.40	0.58	0.20	R-38/ U = 0.031	R-30/ U = 0.034	R-21/ U = 0.060	R-15	R-10	R-30/ U = 0.029	R-10
IV.	Unlimited Group R-3 Occupancy only	0.40	0.58	0.20	R-38	R-30	R-21	R-21	R-10	R-30	R-10
V.	Unlimited Group R-1 Occupancy only	0.35	0.58	0.20	R-38/ U = 0.031	R-30/ U = 0.034	R-21/ U = 0.060	R-15	R-10	R-30/ U = 0.029	R-10

* Reference Case

**TABLE 6-2
PRESCRIPTIVE REQUIREMENTS^{0,1} FOR GROUP R OCCUPANCY
CLIMATE ZONE 2**

Option	Glazing Area ¹⁰ : % of Floor	Glazing U-Factor		Door ⁹ U-Factor	Ceiling ²	Vaulted Ceiling ³	Wall ¹² Above Grade	Wall• int ⁴ Below Grade	Wall• ext ⁴ Below Grade	Floor ⁵	Slab ⁶ on Grade
		Vertical	Overhead ¹¹								
I.	10%	0.40	0.58	0.20	R-38	R-30	R-21 Int ⁷	R-21	R-12	R-30	R-10
II.*	15%	0.40	0.58	0.20	R-38	R-30	R-19 +R-5 ⁸	R-21	R-12	R-30	R-10
III.	17%	0.37	0.58	0.20	R-38	R-30	R-19 +R-5 ⁸	R-21	R-12	R-30	R-10
IV.	25% Group R-1 Occupancy only	0.35	0.58	0.20	R-38/ U = 0.031	R-30/ U = 0.034	R-21 int ⁷ / U = 0.054	R-15	R-12	R-30/ U = 0.029	R-10 /F = 0.54
V.	Unlimited Group R-3 Occupancy only	0.35	0.58	0.20	R-38	R-30	R-21 Int ⁷	R-21	R-12	R-30	R-10
VI.	Unlimited Group R-1 Occupancy only	0.32	0.58	0.20	R-38/ U = 0.031	R-30/ U = 0.034	R-21 int ⁷ / U = 0.054	R-15	R-12	R-30/ U = 0.029	R-10 /F = 0.54

* Reference Case

comply with Table 6-1 or 6-2. System sizing shall be determined by an analysis consistent with section 503.2 of this Code, or, when approved by the building official, Chapter 9. All mechanical equipment efficiencies and service water heating system efficiencies shall comply with standards as stated in sections 503 and 504 of this Code.

[Statutory Authority: RCW 19.27A.025, 19.27A.045. 02-01-112, § 51-11-0603, filed 12/18/01, effective 7/1/02. Statutory Authority: Chapters 19.27, 19.27A and 34.05 RCW. 94-05-059, § 51-11-0603, filed 2/10/94, effective 4/1/94. Statutory Authority: RCW 19.27A.020 and 1990 c 2. 91-01-112, § 51-11-0603, filed 12/19/90, effective 7/1/91.]

WAC 51-11-0604 Reserved.

[Statutory Authority: RCW 19.27A.025, 19.27A.045. 01-03-010, § 51-11-0604, filed 1/5/01, effective 7/1/01. Statutory Authority: RCW 19.27A.020 and 1990 c 2. 91-01-112, § 51-11-0604, filed 12/19/90, effective 7/1/91.]

WAC 51-11-0605 Lighting. Lighting shall comply with Section 505.

[Statutory Authority: RCW 19.27A.025, 19.27A.045. 01-03-010, § 51-11-0605, filed 1/5/01, effective 7/1/01. Statutory Authority: RCW 19.27A.025. 93-21-052, § 51-11-0605, filed 10/18/93, effective 4/1/94. Statutory Authority: RCW 19.27A.020 and 1990 c 2. 91-01-112, § 51-11-0605, filed 12/19/90, effective 7/1/91.]

0. Nominal R-values are for wood frame assemblies only or assemblies built in accordance with Section 601.1.
1. Minimum requirements for each option listed. For example, if a proposed design has a glazing ratio to the conditioned floor area of 13%, it shall comply with all of the requirements of the 15% glazing option (or higher). Proposed designs which cannot meet the specific requirements of a listed option above may calculate compliance by Chapters 4 or 5 of this Code.
2. Requirement applies to all ceilings except single rafter or joist vaulted ceilings. 'Adv' denotes Advanced Framed Ceiling.
3. Requirement applicable only to single rafter or joist vaulted ceilings.
4. Below grade walls shall be insulated either on the exterior to a minimum level of R-10, or on the interior to the same level as walls above grade. Exterior insulation installed on below grade walls shall be a water resistant material, manufactured for its intended use, and installed according to the manufacturer's specifications. See Section 602.2.
5. Floors over crawl spaces or exposed to ambient air conditions.
6. Required slab perimeter insulation shall be a water resistant material, manufactured for its intended use, and installed according to manufacturer's specifications. See Section 602.4.
7. Int. denotes standard framing 16 inches on center with headers insulated with a minimum of R-5 insulation.
8. This wall insulation requirement denotes R-19 wall cavity insulation plus R-5 foam sheathing.
9. Doors, including all fire doors, shall be assigned default U-factors from Table 10-6C.
10. Where a maximum glazing area is listed, the total glazing area (combined vertical plus overhead) as a percent of gross conditioned floor area shall be less than or equal to that value. Overhead glazing with U-factor of U=0.40 or less is not included in glazing area limitations.
11. Overhead glazing shall have U-factors determined in accordance with NFRC 100 or as specified in Section 502.1.5.
12. Log and solid timber walls with a minimum average thickness of 3.5" are exempt from this insulation requirement.

[Statutory Authority: RCW 19.27A.020, 19.27A.045, 02-24-076, § 51-11-0625, filed 12/4/02, effective 5/1/03. Statutory Authority: RCW 19.27A.025, 19.27A.045, 02-01-112, § 51-11-0625, filed 12/18/01, effective 7/1/02; 01-03-010, § 51-11-0625, filed 1/5/01, effective 7/1/01; 98-03-003, § 51-11-0625, filed 1/8/98, effective 7/1/98. Statutory Authority: Chapters 19.27 and 19.27A RCW and 1994 c 226, 95-01-126, § 51-11-0625, filed 12/21/94, effective 6/30/95. Statutory Authority: Chapters 19.27, 19.27A and 34.05 RCW, 94-05-059, § 51-11-0625, filed 2/10/94, effective 4/1/94. Statutory Authority: Chapter 19.27A RCW, 92-01-140, § 51-11-0625, filed 12/19/91, effective 7/1/92.]

WAC 51-11-0626 Table 6-2—Reserved.

[Statutory Authority: RCW 19.27A.025, 19.27A.045, 02-01-112, § 51-11-0626, filed 12/18/01, effective 7/1/02; 01-03-010, § 51-11-0626, filed 1/5/01, effective 7/1/01; 98-03-003, § 51-11-0626, filed 1/8/98, effective 7/1/98. Statutory Authority: Chapters 19.27 and 19.27A RCW and 1994 c 226, 95-01-126, § 51-11-0626, filed 12/21/94, effective 6/30/95. Statutory Authority: Chapters 19.27, 19.27A and 34.05 RCW, 94-05-059, § 51-11-0626, filed 2/10/94, effective 4/1/94. Statutory Authority: Chapter 19.27A RCW, 92-01-140, § 51-11-0626, filed 12/19/91, effective 7/1/92.]

WAC 51-11-0627 Table 6-3—Reserved.

[Statutory Authority: RCW 19.27A.025, 19.27A.045, 02-01-112, § 51-11-0627, filed 12/18/01, effective 7/1/02; 01-03-010, § 51-11-0627, filed 1/5/01, effective 7/1/01; 98-03-003, § 51-11-0627, filed 1/8/98, effective 7/1/98. Statutory Authority: Chapters 19.27 and 19.27A RCW and 1994 c 226, 95-01-126, § 51-11-0627, filed 12/21/94, effective 6/30/95. Statutory Authority: Chapters 19.27, 19.27A and 34.05 RCW, 94-05-059, § 51-11-0627, filed 2/10/94, effective 4/1/94. Statutory Authority: Chapter 19.27A RCW, 92-01-140, § 51-11-0627, filed 12/19/91, effective 7/1/92.]

WAC 51-11-0628 Table 6-4—Reserved.

[Statutory Authority: RCW 19.27A.025, 19.27A.045, 02-01-112, § 51-11-0628, filed 12/18/01, effective 7/1/02; 01-03-010, § 51-11-0628, filed 1/5/01, effective 7/1/01; 98-03-003, § 51-11-0628, filed 1/8/98, effective 7/1/98. Statutory Authority: Chapters 19.27 and 19.27A RCW and 1994 c 226, 95-01-126, § 51-11-0628, filed 12/21/94, effective 6/30/95. Statutory Authority: Chapters 19.27, 19.27A and 34.05 RCW, 94-05-059, § 51-11-0628, filed 2/10/94, effective 4/1/94. Statutory Authority: Chapter 19.27A RCW, 92-01-140, § 51-11-0628, filed 12/19/91, effective 7/1/92.]

WAC 51-11-0629 Table 6-5—Reserved.

[Statutory Authority: RCW 19.27A.025, 19.27A.045, 02-01-112, § 51-11-0629, filed 12/18/01, effective 7/1/02; 98-03-003, § 51-11-0629, filed 1/8/98, effective 7/1/98. Statutory Authority: Chapters 19.27 and 19.27A RCW and 1994 c 226, 95-01-126, § 51-11-0629, filed 12/21/94, effective 6/30/95. Statutory Authority: Chapters 19.27, 19.27A and 34.05 RCW, 94-05-059, § 51-11-0629, filed 2/10/94, effective 4/1/94. Statutory Authority: Chapter 19.27A RCW, 92-01-140, § 51-11-0629, filed 12/19/91, effective 7/1/92.]

WAC 51-11-0630 Table 6-6—Reserved.

[Statutory Authority: RCW 19.27A.025, 19.27A.045, 02-01-112, § 51-11-0630, filed 12/18/01, effective 7/1/02; 01-03-010, § 51-11-0630, filed 1/5/01, effective 7/1/01; 98-03-003, § 51-11-0630, filed 1/8/98, effective 7/1/98. Statutory Authority: Chapters 19.27 and 19.27A RCW and 1994 c 226, 95-01-126, § 51-11-0630, filed 12/21/94, effective 6/30/95. Statutory Authority: Chapters 19.27, 19.27A and 34.05 RCW, 94-05-059, § 51-11-0630, filed 2/10/94, effective 4/1/94. Statutory Authority: Chapter 19.27A RCW, 92-01-140, § 51-11-0630, filed 12/19/91, effective 7/1/92.]

WAC 51-11-0631 Table 6-7—Reserved.

[Statutory Authority: RCW 19.27A.025, 93-21-052, § 51-11-0631, filed 10/18/93, effective 4/1/94. Statutory Authority: Chapter 19.27A RCW, 92-01-140, § 51-11-0631, filed 12/19/91, effective 7/1/92.]

WAC 51-11-0700 Chapter 7—Standards.

[Statutory Authority: RCW 19.27A.020 and 1990 c 2, 91-01-112, § 51-11-0700, filed 12/19/90, effective 7/1/91.]

WAC 51-11-0701 Scope. The following standards shall apply to Chapters 1 through 20. The standards and portions thereof, which are referred to in various parts of this Code shall be part of the Washington State Energy Code and are hereby declared to be a part of this Code.

REFERENCE STANDARD

NO.	TITLE AND SOURCE
RS-1	Same as RS-27.
RS-2	through RS-3 (Reserved.)
RS-4	ASHRAE Standard 55-92 Thermal Environmental Conditions for Human Occupancy.
RS-5	through RS-8 (Reserved.)
RS-9	ASHRAE/IES Standard 90.1-1989, Efficient Design of New Buildings Except New Low-Rise Residential Buildings.
RS-10	Standard for Packaged Terminal Air Conditioners and Heat Pumps, ARI Standard 310/380-93.
RS-11	1999 ASHRAE HVAC Systems and Applications Handbook.
RS-12	through RS-14 (Reserved.)
RS-15	1996 ASHRAE System and Equipment Handbook.
RS-16	SMACNA, Installation Standards for Residential Heating and Air Conditioning Systems, 6th Edition, 1988.
RS-17	Same as RS-18.
RS-18	SMACNA, HVAC Duct Construction Standards Metal and Flexible, 2nd Edition, 1995.

REFERENCE STANDARD NO.	TITLE AND SOURCE
RS-19	SMACNA, Fibrous Glass Duct Construction Standards, 6th Edition, 1992.
RS-20	1998 ASHRAE Refrigeration Handbook.
RS-21	Same as Standard RS-10.
RS-22	through RS-24 (Reserved.)
RS-25	Same as RS-27.
RS-26	Super Good Cents Technical Reference (Builder's Field Guide).
RS-27	1997 ASHRAE Fundamentals Handbook.
RS-28	(Reserved.)
RS-29	Nonresidential Building Design by Systems Analysis.
RS-30	Title 10, Code of Federal Regulations (CFR), Part 430 (March 14, 1988).
RS-31	National Fenestration Rating Council (NFRC) Standard 100-1997.

ACCREDITED AUTHORITATIVE AGENCIES

ANSI refers to the American National Standards Institute, Inc., 11 West 42nd Street, New York, NY 10036
Phone (212) 642-4900 Fax (212) 398-0023, Internet www.ansi.org

ARI refers to the Air Conditioning and Refrigeration Institute, 4301 N. Fairfax Dr., Suite 425, Arlington, VA 22203
Phone (703) 524-8800 Fax (703) 528-3816, Internet www.ari.org

ASHRAE refers to the American Society of Heating, Refrigerating, and Air Conditioning Engineers, Inc., 1791 Tullie Circle, N.E., Atlanta, GA 30329
Phone (404) 636-8400 Fax (404) 321-5478, Internet www.ashrae.org

ASTM refers to the American Society for Testing and Materials, 100 Barr Harbor Drive, West Conshohocken, PA 19428-2959
Phone (610) 832-9585 Fax (610) 832-9555, Internet www.astm.org

CTI refers to the Cooling Tower Institute, 530 Wells Fargo Drive, Suite 218, Houston, TX 77090
Phone (281) 583-4087 Fax (281) 537-1721, Internet www.cti.org

IES refers to the Illuminating Engineering Society, 120 Wall Street, Floor 17, New York, NY 10005-4001
Phone (212) 248-5000 Fax (212) 248-5017, Internet www.iesna.org

NFRC refers to the National Fenestration Rating Council, Incorporated, 1300 Spring Street, Suite 500, Silver Spring, Maryland 20910
Phone (301) 589-NFRC Fax (301) 588-0854, Internet www.nfrc.org

SMACNA refers to the Sheet Metal and Air Conditioning Contractors National Association, Inc., 4201 Lafayette Center Drive, P.O. Box 221230, Chantilly, VA 20153-1230

(2003 Ed.)

Phone (703) 803-2980 Fax (703) 803-3732, Internet www.smacna.org

[Statutory Authority: RCW 19.27A.025, 19.27A.045. 01-03-010, § 51-11-0701, filed 1/5/01, effective 7/1/01; 98-03-003, § 51-11-0701, filed 1/8/98, effective 7/1/98. Statutory Authority: RCW 19.27A.020 and 1990 c 2. 91-01-112, § 51-11-0701, filed 12/19/90, effective 7/1/91.]

WAC 51-11-0800 Section 0800—Suggested software for chapter 4 systems analysis approach for Group R Occupancy.

Program Name:	Source
CALPAS 3	BSG Software 40 Lincoln Street Lexington, MA 02173 (617) 861-0109
DOE 2	ACROSOF/CAER Engineers 1204-1/2 Washington Avenue Golden, CO 80401 (303) 279-8136
F-LOAD	F-CHART SOFTWARE 4406 Fox Bluff Rd. Middleton, WI 53562 (608) 836-8531
MICROPAS	ENERCOMP 1721 Arroyo Drive Auburn, CA 95603 (800) 755-5903
SUNDAY	ECOTOPE 2812 East Madison St. Seattle, WA 98112 (206) 322-3753

[Statutory Authority: RCW 19.27A.020, 19.27A.045. 02-24-076, § 51-11-0800, filed 12/4/02, effective 5/1/03. Statutory Authority: RCW 19.27A.025 and 19.27A.045. 98-03-003, § 51-11-0800, filed 1/8/98, effective 7/1/98. Statutory Authority: RCW 19.27A.020 and 1990 c 2. 91-01-112, § 51-11-0800, filed 12/19/90, effective 7/1/91.]

WAC 51-11-0900 Section 0900—Prescriptive heating system sizing. When using the prescriptive approach in Chapter 6, if approved by the building official, design heat load calculations are not required to show compliance to this Code if the heating system installed is equal to or less than the following:

Climate Zone 1	20 Btu/h•ft ²
Climate Zone 2	25 Btu/h•ft ²

Example: A 2000 ft² house in Zone 2, heated with gas, would not have to submit a design heat load if the proposed furnace is 50,000 Btu or less.

$$2000 \times 25 = 50,000$$

Disclaimer: All heating systems shall be designed and installed in accordance with Uniform Building Code Section 310.11.

[Statutory Authority: RCW 19.27A.025, 19.27A.045. 02-01-112, § 51-11-0900, filed 12/18/01, effective 7/1/02. Statutory Authority: Chapters 19.27 and 19.27A RCW and 1994 c 226. 95-01-126, § 51-11-0900, filed 12/21/94, effective 6/30/95. Statutory Authority: RCW 19.27A.020 and 1990 c 2. 91-01-112, § 51-11-0900, filed 12/19/90, effective 7/1/91.]

WAC 51-11-1000 Chapter 10.

Section 1000 Default heat-loss coefficients.

[Statutory Authority: Chapter 19.27A RCW. 92-01-140, § 51-11-1000, filed 12/19/91, effective 7/1/92. Statutory Authority: RCW 19.27A.020 and 1990 c 2. 91-01-112, § 51-11-1000, filed 12/19/90, effective 7/1/91.]

WAC 51-11-1001 Section 1001 General.

1001.1 Scope: The following defaults shall apply to Chapters 1 through 20. This chapter includes tables of seasonal average heat-loss coefficients for specified nominal insulation. The heat-loss coefficients may also be used for heating system sizing.

1001.2 Description: These coefficients were developed primarily from data and procedures from Standard RS-27, and taken specifically from Standard RS-26, listed in Chapter 7.

Coefficients not contained in this chapter may be computed using the procedures listed in these references if the assumptions in the following sections and Standard RS-26, listed in Chapter 7, are used, along with data from the sources referenced above.

1001.3 **Air Films:** Default R-values used for air films shall be as follows:

R-Value	Condition
0.17	All exterior surfaces
0.61	Interior horizontal surfaces, heat flow up
0.92	Interior horizontal surfaces, heat flow down
0.68	Interior vertical surfaces

1001.4 **Compression of Insulation:** Insulation which is compressed shall be rated in accordance with Table 10-A or reduction in value may be calculated in accordance with the procedures in Standard RS-27, listed in Chapter 7.

**TABLE 10-A
R-Value of Fiberglass Batts Compressed within Various Depth Cavities**

R-Value		38	30	22	21	19	15	13	11	8	5	3
Standard Thickness		12"	9-1/2"	6-3/4"	5-1/2"	6-1/4"	3-1/2"	3-5/8"	3-1/2"	2-1/2"	1-1/2"	3/4"
Nominal Lumber Sizes, Inches	Actual Depth of Cavity, Inches	Insulation R-Values when Installed in a Confined Cavity										
2 x 12	11-1/4	37	—	—	—	—	—	—	—	—	—	—
2 x 10	9-1/4	32	30	—	—	—	—	—	—	—	—	—
2 x 8	7-1/4	27	26	—	—	—	—	—	—	—	—	—
2 x 6	5-1/2	—	21	20	21	18	—	—	—	—	—	—
2 x 4	3-1/2	—	—	14	—	13	15	13	11	—	—	—
2 x 3	2-1/2	—	—	—	—	—	—	9.8	—	—	—	—
2 x 2	1-1/2	—	—	—	—	—	—	6.3	6.0	5.7	5.0	—
2 x 1	3/4	—	—	—	—	—	—	—	—	—	3.2	3.0

[Statutory Authority: RCW 19.27A.025, 19.27A.045. 01-03-010, § 51-11-1001, filed 1/5/01, effective 7/1/01. Statutory Authority: RCW 19.27A.020 and 1990 c 2. 91-01-112, § 51-11-1001, filed 12/19/90, effective 7/1/91.]

WAC 51-11-1002 Section 1002: Below grade walls and slabs.

1002.1 General: Table 10-1 lists heat-loss coefficients for below-grade walls and floors.

Coefficients for below-grade walls are given as U-factors (Btu/hr•ft²•°F of wall area). Coefficients for below-grade slabs are listed as F-factors (Btu/hr•ft•°F per lineal foot of slab perimeter).

Below-grade wall U-factors are only valid when used with the accompanying below-grade slab F-factors, and vice versa.

1002.2 Component Description: All below-grade walls are assumed to be eight-inch concrete. The wall is assumed to extend from the slab upward to the top of the mud sill for the distance specified in Table 10-1, with six inches of concrete wall extending above grade.

Interior insulation is assumed to be fiberglass batts placed in the cavity formed by 2x4 framing on twenty-four inch centers with one-half inch of gypsum board as the interior finish material.

Exterior insulation is assumed to be applied directly to the exterior of the below-grade wall from the top of the wall to the footing. The exterior case does not assume any interior framing or sheetrock.

In all cases, the entire wall surface is assumed to be insulated to the indicated nominal level with the appropriate framing and insulation application. Coefficients are listed for wall depths of two, three and one-half, and seven feet below grade. Basements shallower than two feet should use on-grade slab coefficients.

Heat-loss calculations for wall areas above grade should use above-grade wall U-factors, beginning at the mudsill.

1002.3 Insulation Description: Coefficients are listed for the following four configurations:

1. Uninsulated: No insulation or interior finish.
2. Interior insulation: Interior 2x4 insulated wall without a thermal break between concrete wall and slab.
3. Interior insulation w/thermal break: Interior 2x4 insulated wall with R-5 rigid board providing a thermal break between the concrete wall and the slab.
4. Exterior insulation: Insulation applied directly to the exterior surface of the concrete wall.

TABLE 10-1
DEFAULT WALL U-FACTORS AND SLAB F-FACTORS FOR BASEMENTS

	Below Grade Wall U-factor	Below Grade Slab F-factor
2-Foot Depth Below Grade		
Uninsulated	0.350	0.59
R-11 Interior	0.066	0.68
R-11 Interior w/tb	0.070	0.60
R-19 Interior	0.043	0.69
R-19 Interior w/tb	0.045	0.61
R-10 Exterior	0.070	0.60
R-12 Exterior	0.061	0.60
3.5-Foot Depth Below Grade		
Uninsulated	0.278	0.53
R-11 Interior	0.062	0.63
R-11 Interior w/tb	0.064	0.57
R-19 Interior	0.041	0.64
R-19 Interior w/tb	0.042	0.57
R-10 Exterior	0.064	0.57
R-12 Exterior	0.057	0.57
7-Foot Depth Below Grade		
Uninsulated	0.193	0.46
R-11 Interior	0.054	0.56
R-11 Interior w/tb	0.056	0.42
R-19 Interior	0.037	0.57
R-19 Interior w/tb	0.038	0.43
R-10 Exterior	0.056	0.42
R-12 Exterior	0.050	0.42

[Statutory Authority: RCW 19.27A.025, 19.27A.045, 01-03-010, § 51-11-1002, filed 1/5/01, effective 7/1/01; 98-03-003, § 51-11-1002, filed 1/8/98, effective 7/1/98. Statutory Authority: RCW 19.27A.020 and 1990 c 2, 91-01-112, § 51-11-1002, filed 12/19/90, effective 7/1/91.]

WAC 51-11-1003 Section 1003: On-grade slab floors.

1003.1 General: Table 10-2 lists heat-loss coefficients for heated on-grade slab floors, in units of Btu/h^oF per lineal foot of perimeter.

1003.2 Component Description: All on-grade slab floors are assumed to be six-inch concrete poured directly onto the earth. The bottom of the slab is assumed to be at grade line. Monolithic and floating slabs are not differentiated.

Soil is assumed to have a conductivity of 0.75 Btu/hr^oF•ft². Slabs two-feet or more below grade should use basement coefficients.

1003.3 Insulation Description: Coefficients are provided for the following three configurations:

Two-Foot (or four-foot) vertical: Insulation is applied directly to the slab exterior, extending downward from the top of the slab to a depth of two-feet (or four-feet) below grade.

Two-Foot (or four-foot) horizontal: Insulation is applied directly to the underside of the slab, and run horizontally from the perimeter inward for two-feet or four-feet. The slab edge is exposed in this configuration.

Note: A horizontal installation with a thermal break of at least R-5 at the slab edge should use the vertical-case F-factors.

Fully insulated slab: Insulation extends from the top of the slab, along the entire perimeter, and completely covers the area under the slab. Thicker perimeter insulation covers the slab edge and extends 2 feet under the slab.

TABLE 10-2
DEFAULT F-FACTORS FOR ON-GRADE SLABS

Insulation type	R-0	R-5	R-10	R-15
	Unheated Slab			
Uninsulated slab	0.73	—	—	—
2-ft Horizontal (No thermal break)	—	0.70	0.70	0.69
4-ft Horizontal (No thermal break)	—	0.67	0.64	0.63
2-ft Vertical	—	0.58	0.54	0.52
4-ft Vertical	—	0.54	0.48	0.45
Fully insulated slab	—	—	0.36	—

Insulation type	R-0	R-5	R-10	R-15
	Heated Slab			
Uninsulated slab	0.84	—	—	—
Fully insulated slab	—	0.74	0.55	0.44
R-5 Center (With perimeter insulation)	—	—	0.66	0.62
R-10 Center (With perimeter insulation)	—	—	—	0.51
3-ft Vertical	—	—	0.78	—

[Statutory Authority: RCW 19.27A.025, 19.27A.045, 01-03-010, § 51-11-1003, filed 1/5/01, effective 7/1/01; 98-03-003, § 51-11-1003, filed 1/8/98, effective 7/1/98. Statutory Authority: RCW 19.27A.020 and 1990 c 2. 91-01-112, § 51-11-1003, filed 12/19/90, effective 7/1/91.]

WAC 51-11-1004 Section 1004: Floors over unconditioned space.

1004.1 General: Tables 10-3, 10-4 and 10-4a list heat-loss coefficients for floors over unconditioned spaces in units of Btu/h•ft²•°F.

They are derived from procedures listed in RS-27, listed in Chapter 7, assuming an average outdoor temperature of 45°F, an average indoor temperature of 65°F, and a crawlspace area of 1350 ft² and 100 ft of perimeter. The crawlspace is assumed to be 2.5 feet high, with 24 inches below grade and 6 inches above grade.

1004.2 Crawlspace Description: Four configurations are considered: Vented crawlspace, unvented crawlspace, heated plenum crawlspace and exposed floor.

Vented crawlspaces: Assumed to have 3.0 air-changes per hour, with at least 1.0 ft² of net-free ventilation in the foundation for every three hundred ft² of crawlspace floor area. The crawlspace is not actively heated.

Floors over unheated areas, such as garages, may only use those values which have R-0 perimeter insulation.

Unvented crawlspaces: Assumed to have 1.5 air changes per hour, with less than 1.0 ft² of net-free ventilation in the foundation for every three hundred ft² of crawlspace floor area. The crawlspace is not actively heated. Floors over unheated basements may only use those values which have R-0 perimeter insulation.

Heated-plenum crawlspaces: Assumed to have 0.25 air-changes per hour, with no foundation vents. Heated supply air from central furnace is blown into a crawlspace and allowed to enter the living space unducted via holes cut into the floor.

Enclosed floors: Assumes no buffer space, and a covering of one-half inch of T1-11 on the exterior of the cavity exposed to the outside air or rigid insulation below a concrete floor, such as over parking garages.

1004.3 Construction Description: Floors are assumed to be either joisted floors framed on sixteen inch centers, or post and beam on four by eight foot squares. Insulation is assumed to be installed under the subflooring between the joists or beams with no space between the insulation and the subfloor. Insulation is assumed to be uncompressed. Exposed floors also include concrete with continuous rigid insulation assumed.

Perimeter insulation is assumed to extend from the top of the rim joist to the crawlspace floor and then inward along the ground (on top of the ground cover) for at least twenty-four inches.

Floor coverings are assumed to be light carpet with rubber pad.

**TABLE 10-3
DEFAULT U-FACTORS FOR FLOORS OVER
VENTED CRAWLSPACE OR
UNHEATED BASEMENT**

Floor	Nominal R-value		U-factor	
	Perimeter	Post & Beam	Joists	
0	0	0.112	0.134	
	11	0.100	0.116	
	19	0.098	0.114	
	30	0.093	0.107	
11	0	0.052	0.056	
	11	0.048	0.052	
19	0	0.038	0.041	
	11	0.036	0.038	
22	0	0.034	0.037	
	11	0.033	0.035	
25	0	0.032	0.034	
	11	0.031	0.033	
30	0	0.028	0.029	
	11	0.027	0.028	
38	0	0.024	0.025	
	11	0.024	0.024	

**TABLE 10-4
DEFAULT U-FACTORS FOR FLOORS OVER
HEATED PLENUM CRAWLSPACES**

Nominal R-value	U-factor
Perimeter	
11	0.085
19	0.075
30	0.069

**TABLE 10-4A
EXPOSED FLOOR**

Nominal R-value	U-factor		
	Concrete	Wood Joist	Metal Joist
R-11	0.077	0.088	0.14
R-15	0.059	0.076	0.12
R-19	0.048	0.062	0.11
R-21	0.043	0.057	0.11

Nominal R-value	U-factor		
	Concrete	Wood Joist	Metal Joist
R-25	0.037	0.051	0.10
R-30	0.031	0.040	0.09
R-38	0.025	0.034	0.08

Note: Crawlspace used as heated plenums have approximately 30% higher heat-loss rate than unvented crawlspaces with the same assumed ACH. Default U-values in Table 10-4 reflect this higher rate of heat loss.

[Statutory Authority: RCW 19.27A.025, 19.27A.045, 01-03-010, § 51-11-1004, filed 1/5/01, effective 7/1/01; 98-03-003, § 51-11-1004, filed 1/8/98, effective 7/1/98. Statutory Authority: RCW 19.27A.020 and 1990 c 2, 91-01-112, § 51-11-1004, filed 12/19/90, effective 7/1/91.]

WAC 51-11-1005 Section 1005: Above-grade walls.

Section 1005.1 General: Table 10-5, 10-5A and 10-5B list heat-loss coefficients for the opaque portion of above-grade wood stud frame walls, metal stud frame walls and concrete masonry walls (Btu/h•ft²•°F) respectively. They are derived from procedures listed in RS-27, listed in Chapter 7. For intermediate floor slabs which penetrate the insulated wall, use the concrete wall U-factors in Table 10-5B.

Insulation is assumed to uniformly fill the entire cavity and to be installed as per manufacturer's directions. All walls are assumed to be finished on the inside with one-half inch gypsum wallboard, and on the outside with either beveled wood siding over one-half inch plywood sheathing or with five-eighths inch T1-11 siding. Insulated sheathing (either interior or exterior) is assumed to cover the entire opaque wall surface.

1005.2 Framing Description: For wood stud frame walls, three framing types are considered, and defined as follows:

Standard: Studs framed on sixteen inch centers with double top plate and single bottom plate. Corners use three studs and each opening is framed using two studs. Headers consist of double 2X or single 4X material with an air space left between the header and the exterior sheathing. Interior partition wall/exterior wall intersections use two studs in the exterior wall.

Framing weighting factors: Studs and plates .19
 Insulated cavity .77
 Headers .04

Intermediate: Studs framed on sixteen inch centers with double top plate and single bottom plate. Corners use two studs or other means of fully insulating corners, and each opening is framed by two studs. Headers consist of double 2X material with R-10 insulation between the header and exterior sheathing. Interior partition wall/exterior wall intersections are fully insulated in the exterior wall.

Framing weighting factors: Studs and plates .18
 Insulated cavity .78
 Headers .04

Advanced: Studs framed on twenty-four inch centers with double top plate and single bottom plate. Corners use two studs or other means of fully insulating corners, and one

stud is used to support each header. Headers consist of double 2X material with R-10 insulation between the header and exterior sheathing. Interior partition wall/exterior wall intersections are fully insulated in the exterior wall.

Framing weighting factors: Studs and plates .13
 Insulated cavity .83
 Headers .04

1005.3 Component Description: Default coefficients for four types of walls are listed: single-stud walls, metal stud walls, strap walls, and double-stud walls.

Single-Stud Wall: Assumes either 2x4 or 2x6 studs framed on sixteen or twenty-four inch centers. Headers are solid for 2x4 walls and double 2x for 2x6 walls, with either dead-air or rigid-board insulation in the remaining space.

Metal Stud Wall: Assumes metal studs spaced on 16 or 24 inch centers with insulation installed to fill wall cavities. Continuous rigid board insulation is applied without creating uninsulated voids in the wall assembly.

Strap Wall: Assumes 2x6 studs framed on sixteen or twenty-four inch centers. 2x3 or 2x4 strapping is run horizontally along the interior surface of the wall to provide additional space for insulation.

Double-Stud Wall: Assumes an exterior structural wall and a separate interior, nonstructural wall. Insulation is placed in both wall cavities and in the space between the 2 walls. Stud spacing is assumed to be on 24 inch centers for both walls.

TABLE 10-5

DEFAULT U-FACTORS FOR ABOVE-GRADE WALLS

2 x 4 Single Wood Stud: R-11 Batt

Siding Material/Framing Type				
R-value of Foam Board	Lapped Wood		T1-11	
	STD	ADV	STD	ADV
0	0.088	0.084	0.094	0.090
1	0.080	0.077	0.085	0.082
2	0.074	0.071	0.078	0.075
3	0.069	0.066	0.072	0.070
4	0.064	0.062	0.067	0.065
5	0.060	0.058	0.063	0.061
6	0.056	0.055	0.059	0.057
7	0.053	0.052	0.055	0.054
8	0.051	0.049	0.052	0.051
9	0.048	0.047	0.050	0.049
10	0.046	0.045	0.047	0.046
11	0.044	0.043	0.045	0.044
12	0.042	0.041	0.043	0.042

NOTE:

Nominal Batt R-value:
R-11 at 3.5 inch thickness

Installed Batt R-value:
R-11 in 3.5 inch cavity

2 x 4 Single Wood Stud: R-13 Batt

Siding Material/Framing Type				
R-value of Foam Board	Lapped Wood		T1-11	
	STD	ADV	STD	ADV
0	0.082	0.078	0.088	0.083
1	0.075	0.072	0.080	0.076
2	0.069	0.066	0.073	0.070
3	0.065	0.062	0.068	0.065
4	0.060	0.058	0.063	0.061
5	0.057	0.055	0.059	0.057
6	0.053	0.052	0.056	0.054
7	0.051	0.049	0.052	0.051
8	0.048	0.047	0.050	0.048
9	0.046	0.045	0.047	0.046
10	0.044	0.043	0.045	0.044
11	0.042	0.041	0.043	0.042
12	0.040	0.039	0.041	0.040

NOTE:

Nominal Batt R-value:
R-13 at 3.63 inch thickness

Installed Batt R-value:
R-12.7 in 3.5 inch cavity

2 x 4 Single Wood Stud: R-15 Batt

Siding Material/Framing Type				
R-value of Foam Board	Lapped Wood		T1-11	
	STD	ADV	STD	ADV
0	0.076	0.071	0.081	0.075
1	0.069	0.065	0.073	0.069
2	0.064	0.061	0.068	0.069
3	0.060	0.057	0.063	0.059
4	0.056	0.053	0.059	0.056
5	0.053	0.051	0.055	0.052
6	0.050	0.048	0.052	0.050
7	0.047	0.046	0.049	0.047
8	0.045	0.044	0.047	0.045
9	0.043	0.042	0.044	0.043
10	0.041	0.040	0.042	0.041
11	0.039	0.038	0.041	0.039
12	0.038	0.037	0.039	0.038

NOTE:

Nominal Batt R-value:
R-15 at 3.5 inch thickness

Installed Batt R-value:
R-15 in 3.5 inch cavity

2 x 6 Single Wood Stud: R-19 Batt

NOTE:

Nominal Batt R-value:
R-19 at 6 inch thickness

Installed Batt R-value:
R-18 in 5.5 inch cavity

Siding Material/Framing Type						
R-value of Foam Board	Lapped Wood			T1-11		
	STD	INT	ADV	STD	INT	ADV
0	0.062	0.058	0.055	0.065	0.061	0.058
1	0.058	0.055	0.052	0.060	0.057	0.055
2	0.054	0.052	0.050	0.056	0.054	0.051
3	0.051	0.049	0.047	0.053	0.051	0.049
4	0.048	0.046	0.045	0.050	0.048	0.046
5	0.046	0.044	0.043	0.048	0.046	0.044
6	0.044	0.042	0.041	0.045	0.044	0.042
7	0.042	0.040	0.039	0.043	0.042	0.040
8	0.040	0.039	0.038	0.041	0.040	0.039
9	0.038	0.037	0.035	0.039	0.038	0.037
10	0.037	0.036	0.035	0.038	0.037	0.036
11	0.036	0.035	0.034	0.036	0.035	0.035
12	0.034	0.033	0.033	0.035	0.034	0.033

2 x 6 Single Wood Stud: R-21 Batt

NOTE:

Nominal Batt R-value:
R-21 at 5.5 inch thickness

Installed Batt R-value:
R-21 in 5.5 inch cavity

Siding Material/Framing Type						
R-value of Foam Board	Lapped Wood			T1-11		
	STD	INT	ADV	STD	INT	ADV
0	0.057	0.054	0.051	0.060	0.056	0.053
1	0.054	0.051	0.048	0.056	0.053	0.050
2	0.050	0.048	0.045	0.052	0.050	0.047
3	0.048	0.045	0.043	0.049	0.047	0.045
4	0.045	0.043	0.041	0.047	0.045	0.043
5	0.043	0.041	0.040	0.044	0.042	0.041
6	0.041	0.039	0.038	0.042	0.041	0.039
7	0.039	0.038	0.036	0.040	0.039	0.037
8	0.038	0.036	0.035	0.039	0.037	0.036
9	0.036	0.035	0.034	0.037	0.036	0.035
10	0.035	0.034	0.033	0.036	0.035	0.033
11	0.033	0.033	0.032	0.034	0.033	0.032
12	0.032	0.031	0.031	0.033	0.032	0.031

2 x 6 Single Wood Stud: R-22 Batt

NOTE:

Nominal Batt R-value:
R-22 at 6.75 inch thickness

Installed Batt R-value:
R-20 in 5.5 inch cavity

Siding Material/Framing Type						
R-value of Foam Board	Lapped Wood			T1-11		
	STD	INT	ADV	STD	INT	ADV
0	0.059	0.055	0.052	0.062	0.058	0.054
1	0.055	0.052	0.049	0.057	0.054	0.051
2	0.052	0.049	0.047	0.054	0.051	0.048
3	0.049	0.046	0.044	0.050	0.048	0.046
4	0.046	0.044	0.042	0.048	0.046	0.044
5	0.044	0.042	0.041	0.045	0.043	0.042
6	0.042	0.040	0.039	0.043	0.042	0.040
7	0.040	0.039	0.037	0.041	0.040	0.038
8	0.038	0.037	0.036	0.039	0.038	0.037
9	0.037	0.036	0.035	0.038	0.037	0.035
10	0.035	0.034	0.033	0.036	0.035	0.034
11	0.034	0.033	0.032	0.035	0.034	0.033
12	0.033	0.032	0.031	0.034	0.033	0.032

2 x 6 Single Wood Stud: Two R-11 Batts

NOTE:

Nominal Batt R-value:
R-22 at 7 inch thickness

Installed Batt R-value:
R-18.9 in 5.5 inch cavity

R-value of Foam Board	Siding Material/Framing Type					
	Lapped Wood			T1-11		
	STD	INT	ADV	STD	INT	ADV
0	0.060	0.057	0.054	0.063	0.059	0.056
1	0.056	0.053	0.051	0.059	0.056	0.053
2	0.053	0.050	0.048	0.055	0.052	0.050
3	0.050	0.048	0.046	0.052	0.049	0.047
4	0.047	0.045	0.044	0.049	0.047	0.045
5	0.045	0.043	0.042	0.046	0.045	0.043
6	0.043	0.041	0.040	0.044	0.043	0.041
7	0.041	0.040	0.038	0.042	0.041	0.039
8	0.039	0.038	0.037	0.040	0.039	0.038
9	0.038	0.037	0.036	0.039	0.038	0.036
10	0.036	0.035	0.034	0.037	0.036	0.035
11	0.035	0.034	0.033	0.036	0.035	0.034
12	0.034	0.033	0.032	0.034	0.034	0.033

2 x 8 Single Stud: R-25 Batt

NOTE:

Nominal Batt R-value:
R-25 at 8 inch thickness

Installed Batt R-value:
R-23.6 in 7.25 inch cavity

R-value of Foam Board	Siding Material/Framing Type					
	Lapped Wood			T1-11		
	STD	INT	ADV	STD	INT	ADV
0	0.051	0.047	0.045	0.053	0.049	0.046
1	0.048	0.045	0.043	0.049	0.046	0.044
2	0.045	0.043	0.041	0.047	0.044	0.042
3	0.043	0.041	0.039	0.044	0.042	0.040
4	0.041	0.039	0.037	0.042	0.040	0.038
5	0.039	0.037	0.036	0.040	0.038	0.037
6	0.037	0.036	0.035	0.038	0.037	0.036
7	0.036	0.035	0.033	0.037	0.035	0.034
8	0.035	0.033	0.032	0.035	0.034	0.033
9	0.033	0.032	0.031	0.034	0.033	0.032
10	0.032	0.031	0.030	0.033	0.032	0.031
11	0.031	0.030	0.029	0.032	0.031	0.030
12	0.030	0.029	0.028	0.031	0.030	0.029

2 x 6: Strap Wall

	Siding Material/Frame Type			
	Lapped Wood		T1-11	
	STD	ADV	STD	ADV
R-19 + R-11 Batts	0.036	0.035	0.038	0.036
R-19 + R-8 Batts	0.041	0.039	0.042	0.040

2 x 6 + 2 x 4: Double Wood Stud

Batt Configuration			Siding Material/Frame Type			
			Lapped Wood		T1-11	
Exterior	Middle	Interior	STD	ADV	STD	ADV
R-19	————	R-11	0.040	0.037	0.041	0.038
R-19	————	R-19	0.034	0.031	0.035	0.032
R-19	R-8	R-11	0.029	0.028	0.031	0.029
R-19	R-11	R-11	0.027	0.026	0.028	0.027
R-19	R-11	R-19	0.024	0.023	0.025	0.023
R-19	R-19	R-19	0.021	0.020	0.021	0.020

2 x 4 + 2 x 4: Double Wood Stud

Batt Configuration			Siding Material/Frame Type			
			Lapped Wood		T1-11	
Exterior	Middle	Interior	STD	ADV	STD	ADV
R-11	_____	R-11	0.050	0.046	0.052	0.048
R-19	_____	R-11	0.039	0.037	0.043	0.039
R-11	R-8	R-11	0.037	0.035	0.036	0.036
R-11	R-11	R-11	0.032	0.031	0.033	0.032
R-13	R-13	R-13	0.029	0.028	0.029	0.028
R-11	R-19	R-11	0.026	0.026	0.027	0.026

Log Walls

Average Log Diameter, Inches	U-factor
6	0.148
8	0.111
10	0.089
Average wall thickness 12	0.074
90% average log diameter 14	0.063
16	0.056

NOTE:

R-value of wood:
 R-1.25 per inch thickness

 Average wall thickness
 90% average log diameter

Stress Skin Panel

Panel Thickness, Inches	U-factor
3 1/2	0.071
5 1/2	0.048
7 1/4	0.037
9 1/4	0.030
11 1/4	0.025

NOTE:

R-value of expanded poly-styrene: R-3.85 per inch

 Framing: 6%
 Spline: 8%
 No thermal bridging between interior and exterior splines

Metal Stud Walls: The nominal R-values in Table 10-5A may be used for purposes of calculating metal stud wall section U-factors in lieu of the ASHRAE zone calculation method as provided in Chapter 24 of Standard RS-27.

TABLE 10-5A

Default U-factors for Overall Assembly Metal Stud Walls, Effective R-values for Metal Framing and Cavity Only, and Default Metal Building U-factors

OVERALL ASSEMBLY U-FACTORS FOR METAL STUD WALLS

Metal Framing	R-Value of Continuous Foam Board Insulation	Cavity Insulation					
		R-11	R-13	R-15	R-19	R-21	R-25
16" o.c.	R-0 (none)	U-0.14	U-0.13	U-0.12	U-0.10	U-0.097	U-0.091
	R-1	U-0.12	U-0.12	U-0.11	U-0.094	U-0.089	U-0.083
	R-2	U-0.11	U-0.10	U-0.099	U-0.086	U-0.081	U-0.077
	R-3	U-0.10	U-0.095	U-0.090	U-0.079	U-0.075	U-0.071
	R-4	U-0.091	U-0.087	U-0.082	U-0.073	U-0.070	U-0.067
	R-5	U-0.083	U-0.080	U-0.076	U-0.068	U-0.065	U-0.062
	R-6	U-0.077	U-0.074	U-0.071	U-0.064	U-0.061	U-0.059
	R-7	U-0.071	U-0.069	U-0.066	U-0.060	U-0.058	U-0.055
	R-8	U-0.067	U-0.064	U-0.062	U-0.057	U-0.055	U-0.053
	R-9	U-0.062	U-0.060	U-0.058	U-0.054	U-0.052	U-0.050
	R-10	U-0.059	U-0.057	U-0.055	U-0.051	U-0.049	U-0.048
24" o.c.	R-0 (none)	U-0.13	U-0.12	U-0.11	U-0.091	U-0.085	U-0.079
	R-1	U-0.11	U-0.10	U-0.098	U-0.084	U-0.078	U-0.073
	R-2	U-0.10	U-0.091	U-0.089	U-0.077	U-0.073	U-0.068
	R-3	U-0.092	U-0.083	U-0.082	U-0.072	U-0.068	U-0.064
	R-4	U-0.084	U-0.077	U-0.076	U-0.067	U-0.063	U-0.060
	R-5	U-0.078	U-0.071	U-0.070	U-0.063	U-0.060	U-0.057
	R-6	U-0.072	U-0.067	U-0.066	U-0.059	U-0.056	U-0.054
	R-7	U-0.067	U-0.063	U-0.062	U-0.056	U-0.053	U-0.051
	R-8	U-0.063	U-0.059	U-0.058	U-0.053	U-0.051	U-0.048
	R-9	U-0.059	U-0.056	U-0.055	U-0.050	U-0.048	U-0.046
	R-10	U-0.056	U-0.053	U-0.052	U-0.048	U-0.046	U-0.044

EFFECTIVE R-VALUES FOR METAL FRAMING AND CAVITY ONLY

	Cavity		Insulation		
	Nominal Depth, Inches	Actual Depth, Inches	Nominal R-Value	Effective R-Value	
				16" O.C.	24" O.C.
Air Cavity	any	any	R-0.91 (air)	0.79	0.91
Wall	4	3-1/2	R-11	5.5	6.6
	4	3-1/2	R-13	6.0	7.2
	4	3-1/2	R-15	6.4	7.8
	6	5-1/2	R-19	7.1	8.6
	6	5-1/2	R-21	7.4	9.0
	8	7-1/4	R-25	7.8	9.6
Roof	Insulation is uncompressed		R-11	5.5	6.1
			R-19	7.0	9.1
			R-30	9.3	11.4

DEFAULT METAL BUILDING U-FACTORS

	R-10	R-11	R-13	R-19	R-24	R-30
Faced fiber glass blanket insulation rolled over and perpendicular to structural frame. Metal covering sheets fastened to the frame, holding insulation in place.	0.133	0.127	0.114	0.091	na	na
Faced fiber glass batt insulation suspended between structural frame. Metal covering sheets fastened directly to frame.	0.131	0.123	0.107	0.079	0.065	0.057
Faced fiber glass blanket insulation rolled over and perpendicular to structural frame. Rigid insulation blocks placed over insulation to align with structural frame.	0.102	0.096	0.084	0.065	na	na
Faced fiber glass batt insulation suspended between structural frame. Rigid insulation blocks placed over insulation to align with structural frame.	0.099	0.093	0.080	0.059	0.048	0.041

Concrete Masonry Walls: The nominal R-values in Table 10-5B may be used for purposes of calculating concrete masonry wall section U-factors in lieu of the ASHRAE isothermal planes calculation method as provided in Chapter 24 of Standard RS-27.

TABLE 10-5B
Default U-Factors for Concrete and Masonry Walls

8" CONCRETE MASONRY				
WALL DESCRIPTION	CORE TREATMENT			
	Partial Grout with UngROUTED Cores			Solid Grout
	Empty	Loose-fill insulated		
		Perlite	Vermiculite	
Exposed Block, Both Sides	0.40	0.23	0.24	0.43
R-5 Interior Insulation, Wood Furring	0.14	0.11	0.12	0.15
R-6 Interior Insulation, Wood Furring	0.14	0.11	0.11	0.14
R-10.5 Interior Insulation, Wood Furring	0.11	0.09	0.09	0.11
R-8 Interior Insulation, Metal Clips	0.11	0.09	0.09	0.11
R-6 Exterior Insulation	0.12	0.10	0.10	0.12
R-10 Exterior Insulation	0.08	0.07	0.07	0.08
R-9.5 Rigid Polystyrene Integral Insulation, Two Webbed Block	0.11	0.09	0.09	0.12

12" CONCRETE MASONRY				
WALL DESCRIPTION	CORE TREATMENT			
	Partial Grout with UngROUTED Cores			Solid Grout
	Empty	Loose-fill insulated		
		Perlite	Vermiculite	
Exposed Block, Both Sides	0.35	0.17	0.18	0.33
R-5 Interior Insulation, Wood Furring	0.14	0.10	0.10	0.13
R-6 Interior Insulation, Wood Furring	0.13	0.09	0.10	0.13
R-10.5 Interior Insulation, Wood Furring	0.11	0.08	0.08	0.10
R-8 Interior Insulation, Metal Clips	0.10	0.08	0.08	0.09

12" CONCRETE MASONRY				
	CORE TREATMENT			
	Partial Grout with UngROUTED Cores			Solid Grout
	Empty	Loose-fill insulated		
		Perlite	Vermiculite	
R-6 Exterior Insulation	0.11	0.09	0.09	0.11
R-10 Exterior Insulation	0.08	0.06	0.06	0.08
R-9.5 Rigid Polystyrene Integral Insulation, Two Webbed Block	0.11	0.08	0.09	0.12

8" CLAY BRICK				
WALL DESCRIPTION	CORE TREATMENT			
	Partial Grout with UngROUTED Cores			Solid Grout
	Empty	Loose-fill insulated		
		Perlite	Vermiculite	
Exposed Block, Both Sides	0.50	0.31	0.32	0.56
R-5 Interior Insulation, Wood Furring	0.15	0.13	0.13	0.16
R-6 Interior Insulation, Wood Furring	0.15	0.12	0.12	0.15
R-10.5 Interior Insulation, Wood Furring	0.12	0.10	0.10	0.12
R-8 Interior Insulation, Metal Clips	0.11	0.10	0.10	0.11
R-6 Exterior Insulation	0.12	0.11	0.11	0.13
R-10 Exterior Insulation	0.08	0.08	0.08	0.09

6" CONCRETE POURED OR PRECAST				
WALL DESCRIPTION	CORE TREATMENT			
	Partial Grout with UngROUTED Cores			Solid Grout
	Empty	Loose-fill insulated		
		Perlite	Vermiculite	
Exposed Concrete, Both Sides	NA	NA	NA	0.61
R-5 Interior Insulation, Wood Furring	NA	NA	NA	0.16
R-6 Interior Insulation, Wood Furring	NA	NA	NA	0.15
R-10.5 Interior Insulation, Wood Furring	NA	NA	NA	0.12
R-8 Interior Insulation, Metal Clips	NA	NA	NA	0.12
R-6 Exterior Insulation	NA	NA	NA	0.13
R-10 Exterior Insulation	NA	NA	NA	0.09

Notes for Default Table 10-5B

1. Grouted cores at 40" x 48" on center vertically and horizontally in partial grouted walls.
2. Interior insulation values include 1/2" gypsum board on the inner surface.
3. Furring and stud spacing is 16" on center. Insulation is assumed to fill furring space and is not compressed.
4. Intermediate values may be interpolated using this table. Values not contained in this table may be computed using the procedures listed in Standard RS-27.

[Statutory Authority: RCW 19.27A.025, 19.27A.045, 01-03-010, § 51-11-1005, filed 1/5/01, effective 7/1/01; 98-03-003, § 51-11-1005, filed 1/8/98, effective 7/1/98. Statutory Authority: RCW 19.27A.020 and 1990 c 2. 91-01-112, § 51-11-1005, filed 12/19/90, effective 7/1/91.]

WAC 51-11-1006 Section 1006 Default U-factors for glazing and doors.

1006.1 Glazing and Doors without NFRC Certification: Glazing and doors that do not have NFRC certification shall be assigned the following U-factors:

**TABLE 10-6
Other than Group R Occupancy: DEFAULT U-FACTORS
FOR VERTICAL GLAZING, OVERHEAD GLAZING AND
OPAQUE DOORS**

Vertical Glazing	U-Factor	
	Any Frame	Vinyl/Wood Frame
Single	1.45	1.45
Double	0.90	0.75
1/2 Inch Air, Fixed	0.75	0.60
1/2 Inch Air, Low-e ^(0.40) , Fixed	0.60	0.50
1/2 Inch Argon, Low-e ^(0.10) , Fixed	0.50	0.40

Overhead Glazing	U-Factor	
	Any Frame	Vinyl/Wood Frame
Single	2.15	2.15
Double	1.45	1.00
Low-e ^(0.40) or Argon	1.40	0.95
Low-e ^(0.40) + Argon	1.30	0.85

Overhead Glazing		
	U-Factor	
	Any Frame	Vinyl/Wood Frame
Low-e ^(0.20) Air	1.30	0.90
Low-e ^(0.20) + Argon	1.25	0.80
Triple	1.25	0.80

Opaque Doors	
	U-Factor
Uninsulated Metal	1.20
Insulated Metal (Including Fire Door and Smoke Vent)	0.60
Wood	0.50

Notes:

- Where a gap width is listed (i.e.: 1/2 inch), that is the minimum allowed.
- Where a low-emissivity emittance is listed (i.e.: 0.40, 0.20, 0.10), that is the maximum allowed.
- Where a gas other than air is listed (i.e.: Argon), the gas fill shall be a minimum of 90%.
- Where an operator type is listed (i.e.: Fixed), the default is only allowed for that operator type.
- Where a frame type is listed (i.e.: Wood/vinyl), the default is only allowed for that frame type. Wood/vinyl frame includes reinforced vinyl and aluminum-clad wood.

TABLE 10-6A
Group R Occupancy: DEFAULT U-FACTORS FOR VERTICAL GLAZING

Description ^{1,2,3,4}			Frame Type ^{5,6}		
			Aluminum	Aluminum Thermal Break ⁷	Wood/Vinyl
Windows	Single		1.20	1.20	1.20
	Double, < 1/2"	Clear	0.92	0.75	0.63
		Clear + Argon	0.87	0.71	0.60
		Low-e	0.85	0.69	0.58
		Low-e + Argon	0.79	0.62	0.53
	Double, ≥ 1/2"	Clear	0.86	0.69	0.58
		Clear + Argon	0.83	0.67	0.55
		Low-e	0.78	0.61	0.51
		Low-e + Argon	0.75	0.58	0.48
	Triple,	Clear	0.70	0.53	0.43
		Clear + Argon	0.69	0.52	0.41
		Low-e	0.67	0.49	0.40
		Low-e + Argon	0.63	0.47	0.37
Garden Windows	Single		2.60	n.a.	2.31
	Double	Clear	1.81	n.a.	1.61
		Clear + Argon	1.76	n.a.	1.56
		Low-e	1.73	n.a.	1.54
		Low-e + Argon	1.64	n.a.	1.47

- 1 <1/2" = a minimum dead air space of less than 0.5 inches between the panes of glass.
≥ 1/2" = a minimum dead air space of 0.5 inches or greater between the panes of glass.
Where no gap width is listed, the minimum gap width is 1/4".
- 2 Any low-e (emissivity) coating (0.1, 0.2 or 0.4).
- 3 U-factors listed for argon shall consist of sealed, gas-filled insulated units for argon, CO2, SF6, argon/SF6 mixtures and Krypton.
- 4 "Glass block" assemblies may use a U-factor of 0.51.
- 5 Insulated fiberglass framed products shall use wood/vinyl U-factors.
- 6 Aluminum clad wood windows shall use the U-factors listed for wood/vinyl windows.
- 7 Aluminum Thermal Break = An aluminum thermal break framed window shall incorporate the following minimum design characteristics:
 - a) The thermal conductivity of the thermal break material shall be not more than 3.6 Btu-in/h/ft²/°F;
 - b) The thermal break material must produce a gap in the frame material of not less than 0.210 inches; and,
 - c) All metal framing members of the products exposed to interior and exterior air shall incorporate a thermal break meeting the criteria in a) and b) above.

TABLE 10-6B¹

Group R Occupancy: SMALL BUSINESS COMPLIANCE TABLE FOR VERTICAL GLAZING

DESCRIPTION ^{2,3,4,6}	FRAME TYPE ^{7,8}			
	ALUMINUM	ALUM. THERMAL BREAK ⁹	WOOD/VINYL	ALUM. CLAD WOOD/REINFORCED VINYL ¹⁰
Double, Clear 1/4"	0.82	0.66	0.56	0.59
Double, Clear 1/4" + argon	0.77	0.63	0.53	0.56
Double, Low-e4 1/4"	0.76	0.61	0.52	0.54
Double, Low-e2 1/4"	0.73	0.58	0.49	0.51
Double, Low-e1 1/4"	0.70	0.55	0.47	0.49
Double, Low-e4 1/4" + argon	0.70	0.55	0.47	0.49
Double, Low-e2 1/4" + argon	0.66	0.52	0.43	0.46
Double, Low-e1 1/4" + argon	0.64	0.50	0.41	0.43
Double, Clear 3/8"	0.78	0.63	0.54	0.57
Double, Clear 3/8" + argon	0.75	0.60	0.51	0.54
Double, Low-e4 3/8"	0.72	0.57	0.48	0.51
Double, Low-e2 3/8"	0.69	0.54	0.45	0.48
Double, Low-e1 3/8"	0.66	0.51	0.43	0.46
Double, Low-e4 3/8" + argon	0.68	0.53	0.44	0.47
Double, Low-e2 3/8" + argon	0.63	0.49	0.41	0.44
Double, Low-e1 3/8" + argon	0.61	0.47	0.39	0.41
Double, Clear 1/2"	0.75	0.60	0.50	0.54
Double, Clear 1/2" + argon	0.72	0.58	0.48	0.51
Double, Low-e4 1/2"	0.68	0.53	0.44	0.47
Double, Low-e2 1/2"	0.64	0.50	0.40	0.44
Double, Low-e1 1/2"	0.61	0.47	0.35	0.42
Double, Low-e4 1/2" + argon	0.65	0.50	0.42	0.44
Double, Low-e2 1/2" + argon	0.60	0.46	0.37	0.40
Double, Low-e1 1/2" + argon	0.58	0.43	0.35	0.38
Triple, Clear 1/4"	0.66	0.52	0.42	0.44
Triple, Clear 1/4" + argon	0.63	0.49	0.39	0.42
Triple, Low-e4 1/4"	0.64	0.50	0.40	0.40
Triple, Low-e2 1/4"	0.62	0.48	0.39	0.41
Triple, Low-e1 1/4"	0.61	0.47	0.38	0.40
Triple, Low-e4 1/4" + argon	0.60	0.46	0.37	0.39
Triple, Low-e2 1/4" + argon	0.58	0.43	0.34	0.37
Triple, Low-e1 1/4" + argon	0.57	0.42	0.34	0.36
Triple, Clear 1/2"	0.61	0.46	0.37	0.40
Triple, Clear 1/2" + argon	0.59	0.45	0.36	0.38
Triple, Low-e4 1/2"	0.58	0.43	0.35	0.37
Triple, Low-e2 1/2"	0.55	0.41	0.32	0.35
Triple, Low-e1 1/2"	0.54	0.39	0.31	0.33
Triple, Low-e4 1/2" + argon	0.55	0.41	0.32	0.35
Triple, Low-e2 1/2" + argon	0.52	0.38	0.30	0.32
Triple, Low-e1 1/2" + argon	0.51	0.37	0.29	0.31

Footnotes to Table 10-6B

- 1 Subtract 0.02 from the listed default U-factor for nonaluminum spacer. Acceptable spacer materials may include but is not limited to fiberglass, wood and butyl or other material with an equivalent thermal performance.
- 2 1/4" = a minimum dead air space of 0.25 inches between the panes of glass.
3/8" = a minimum dead air space of 0.375 inches between the panes of glass.
1/2" = a minimum dead air space of 0.5 inches between the panes of glass.
Product with air spaces different than those listed above shall use the value for the next smaller air space; i.e. 3/4 inch = 1/2 inch U-factors, 7/16 inch = 3/8 inch U-factors, 5/16 inch = 1/4 inch U-factors.
- 3 Low-e4 (emissivity) shall be 0.4 or less.
Low-e2 (emissivity) shall be 0.2 or less.
Low-e1 (emissivity) shall be 0.1 or less.

- 4 U-factors listed for argon shall consist of sealed, gas-filled insulated units for argon, CO₂, SF₆, and argon/SF₆ mixtures. The following conversion factor shall apply to Krypton gas-filled units: 1/4" or greater with krypton is equivalent to 1/2" argon.
- 5 Reserved.
- 6 "Glass block" assemblies may use a U-factor of 0.51.
- 7 Insulated fiberglass framed products shall use wood/vinyl U-factors.
- 8 Subtract 0.02 from the listed default values for solariums.
- 9 Aluminum Thermal Break = An aluminum thermal break framed window shall incorporate the following minimum design characteristics:
- The thermal conductivity of the thermal break material shall be not more than 3.6 Btu-in/h/ft²/F°;
 - The thermal break material must produce a gap in the frame material of not less than 0.210 inches; and,
 - All metal framing members of the products exposed to interior and exterior air shall incorporate a thermal break meeting the criteria in a) and b) above.
- 10 Aluminum clad wood windows shall use the U-factors listed for Aluminum Clad Wood/Reinforced Vinyl windows. Vinyl clad wood window shall use the U-factors listed for Wood/Vinyl windows. Any vinyl frame window with metal reinforcement in more than one rail shall use the U-factors listed for Aluminum Clad Wood/Reinforced Vinyl window.

TABLE 10-6C
Group R Occupancy: DEFAULT U-FACTORS FOR DOORS

Door Type	No Glazing	Single Glazing	Double Glazing with 1/4 in. Airspace	Double Glazing with 1/2 in. Airspace	Double Glazing with e = 0.10, 1/2 in. Argon
SWINGING DOORS (Rough opening - 38 in. x 82 in.)					
<i>Slab Doors</i>					
Wood slab in wood frame ^a	0.46				
6% glazing (22 in. x 8 in. lite)	-	0.48	0.47	0.46	0.44
25% glazing (22 in. x 36 in. lite)	-	0.58	0.48	0.46	0.42
45% glazing (22 in. x 64 in. lite)	-	0.69	0.49	0.46	0.39
More than 50% glazing		Use Table 10-6A			
Insulated steel slab with wood edge in wood frame ^a	0.16				
6% glazing (22 in. x 8 in. lite)	-	0.21	0.20	0.19	0.18
25% glazing (22 in. x 36 in. lite)	-	0.39	0.28	0.26	0.23
45% glazing (22 in. x 64 in. lite)	-	0.58	0.38	0.35	0.26
More than 50% glazing		Use Table 10-6A			
Foam insulated steel slab with metal edge in steel frame ^b	0.37				
6% glazing (22 in. x 8 in. lite)	-	0.44	0.42	0.41	0.39
25% glazing (22 in. x 36 in. lite)	-	0.55	0.50	0.48	0.44
45% glazing (22 in. x 64 in. lite)	-	0.71	0.59	0.56	0.48
More than 50% glazing		Use Table 10-6A			
Cardboard honeycomb slab with metal edge in steel frame ^b	0.61				
<i>Style and Rail Doors</i>					
Sliding glass doors/French doors		Use Table 10-6A			
<i>Site-Assembled Style and Rail Doors</i>					
Aluminum in aluminum frame	-	1.32	0.99	0.93	0.79
Aluminum in aluminum frame with thermal break	-	1.13	0.80	0.74	0.63
REVOLVING DOORS (Rough opening - 82 in. x 84 in.)					
Aluminum in aluminum frame					
Open	-	1.32	-	-	-
Closed	-	0.65	-	-	-
SECTIONAL OVERHEAD DOORS (Nominal - 10 ft x 10 ft)					
Uninsulated steel (nominal U = 1.15) ^c	1.15	-	-	-	-
Insulated steel (nominal U = 0.11) ^c	0.24	-	-	-	-
Insulated steel with thermal break (nominal U = 0.08) ^c	0.13	-	-	-	-

- a. Thermally broken sill (add 0.03 for nonthermally broken sill)
- b. Nonthermally broken sill
- c. Nominal U-factors are through the center of the insulated panel before consideration of thermal bridges around the edges of the door sections and due to the frame.

TABLE 10-6D
Group R Occupancy: DEFAULT U-FACTORS FOR GLAZED DOORS
 See Table 10-6C

TABLE 10-6E
Group R Occupancy: DEFAULT U-FACTORS FOR OVERHEAD GLAZING

Glazing Type	Frame Type			
	Aluminum without Thermal Break	Aluminum with Thermal Break	Reinforced Vinyl/ Aluminum-Clad Wood or Vinyl	Wood or Vinyl-Clad Wood/ Vinyl without Reinforcing
Single Glazing glass	U-1.58	U-1.51	U-1.40	U-1.18
	U-1.52	U-1.45	U-1.34	U-1.11
Double Glazing air	U-1.05	U-0.89	U-0.84	U-0.67
	U-1.02	U-0.86	U-0.80	U-0.64
Double Glazing, e = 0.20 air	U-0.96	U-0.80	U-0.75	U-0.59
	U-0.91	U-0.75	U-0.70	U-0.54
Double Glazing, e = 0.10 air	U-0.94	U-0.79	U-0.74	U-0.58
	U-0.89	U-0.73	U-0.68	U-0.52
Double Glazing, e = 0.05 air	U-0.93	U-0.78	U-0.73	U-0.56
	U-0.87	U-0.71	U-0.66	U-0.50
Triple Glazing air	U-0.90	U-0.70	U-0.67	U-0.51
	U-0.87	U-0.69	U-0.64	U-0.48
Triple Glazing, e = 0.20 air	U-0.86	U-0.68	U-0.63	U-0.47
	U-0.82	U-0.63	U-0.59	U-0.43
Triple Glazing, e = 0.20 on 2 surfaces air	U-0.82	U-0.64	U-0.60	U-0.44
	U-0.79	U-0.60	U-0.56	U-0.40
Triple Glazing, e = 0.10 on 2 surfaces air	U-0.81	U-0.62	U-0.58	U-0.42
	U-0.77	U-0.58	U-0.54	U-0.38
Quadruple Glazing, e = 0.10 on 2 surfaces air	U-0.78	U-0.59	U-0.55	U-0.39
	U-0.74	U-0.56	U-0.52	U-0.36
	U-0.70	U-0.52	U-0.48	U-0.32

1. U-factors are applicable to both glass and plastic, flat and domed units, all spacers and gaps.
2. Emissivities shall be less than or equal to the value specified.
3. Gap fill shall be assumed to be air unless there is a minimum of 90% argon or krypton.
4. Aluminum frame with thermal break is as defined in footnote 9 to Table 10-6B.

[Statutory Authority: RCW 19.27A.025, 19.27A.045, 02-01-112, § 51-11-1006, filed 12/18/01, effective 7/1/02; 01-03-010, § 51-11-1006, filed 1/5/01, effective 7/1/01; 98-03-003, § 51-11-1006, filed 1/8/98, effective 7/1/98. Statutory Authority: Chapters 19.27, 19.27A and 34.05 RCW. 94-05-059, § 51-11-1006, filed 2/10/94, effective 4/1/94. Statutory Authority: RCW 19.27A.020 and 1990 c 2. 91-01-112, § 51-11-1006, filed 12/19/90, effective 7/1/91.]

attics, vaulted ceilings, and roof decks in units of Btu/h•ft²•°F of ceiling.

They are derived from procedures listed in Standard RS-27, listed in Chapter 7. Ceiling U-factors are modified for the buffering effect of the attic, assuming an indoor temperature of 65° F and an outdoor temperature of 45° F.

Metal Framed Ceilings: The nominal R-values in Table 10-5A - EFFECTIVE R-VALUES FOR METAL FRAMING AND CAVITY ONLY may be used for purposes of calculating metal framed ceiling section U-factors in lieu

WAC 51-11-1007 Section 1007 Ceilings.

1007.1 General: Table 10-7 lists heat-loss coefficients for the opaque portion of exterior ceilings below vented

of the ASHRAE zone calculation method as provided in Chapter 24 of Standard RS-27.

1007.2 Component Description: The four types of ceilings are characterized as follows:

Ceilings Below a Vented Attic: Attic insulation is assumed to be blown-in, loose-fill fiberglass with a K-value of 2.6 hr•ft²•°F/Btu per inch. Full bag count for specified R-value is assumed in all cases. Ceiling dimensions for flat ceiling calculations are forty-five by thirty feet, with a gabled roof having a 4/12 pitch. The attic is assumed to vent naturally at the rate of three air changes per hour through soffit and ridge vents. A void fraction of 0.002 is assumed for all attics with insulation baffles. Standard-framed, un baffled attics assume a void fraction of 0.008.

Attic framing is either standard or advanced. Standard framing assumes tapering of insulation depth around the perimeter with resultant decrease in thermal resistance. An increased R-value is assumed in the center of the ceiling due to the effect of piling leftover insulation. Advanced framing assumes full and even depth of insulation extending to the outside edge of exterior walls. Advanced framing does not change from the default value.

U-factors for flat ceilings below vented attics with standard framing may be modified with the following table:

Roof Pitch	U-Factor for Standard Framing	
	R-30	R-38
4/12	.036	.031
5/12	.035	.030
6/12	.034	.029
7/12	.034	.029

Roof Pitch	U-Factor for Standard Framing	
	R-30	R-38
8/12	.034	.028
9/12	.034	.028
10/12	.033	.028
11/12	.033	.027
12/12	.033	.027

Vented scissored truss attics assume a ceiling pitch of 2/12 with a roof pitch of either 4/12 or 5/12. Unbaffled standard framed scissored truss attics are assumed to have a void fraction of 0.016.

Vaulted Ceilings: Insulation is assumed to be fiberglass batts installed in roof joist cavities. In the vented case, at least 1.5-inches between the top of the batts and the underside of the roof sheathing is left open for ventilation in each cavity. A ventilation rate of 3.0 air changes per hour is assumed. In the unvented or dense pack case, the ceiling cavity is assumed to be fully packed with insulation, leaving no space for ventilation.

Roof Decks: Rigid insulation is applied to the top of roof decking with no space left for ventilation. Roofing materials are attached directly on top of the insulation. Framing members are often left exposed on the interior side.

Metal Truss Framing: Overall system tested values for the roof/ceiling U_o for metal framed truss assemblies from approved laboratories shall be used, when such data is acceptable to the building official.

Alternatively, the U_o for roof/ceiling assemblies using metal truss framing may be obtained from Tables 10-7A, 10-7B, 10-7C, 10-7D and 10-7E.

**TABLE 10-7
DEFAULT U-FACTORS FOR CEILINGS**

Ceilings Below Vented Attics

Flat Ceiling	Standard Frame	Advanced Frame
	Baffled	
R-19	0.049	0.047
R-30	0.036	0.032
R-38	0.031	0.026
R-49	0.027	0.020
R-60	0.025	0.017
Scissored Truss		
R-30 (4/12 roof pitch)	0.043	0.031
R-38 (4/12 roof pitch)	0.040	0.025
R-49 (4/12 roof pitch)	0.038	0.020
R-30 (5/12 roof pitch)	0.039	0.032
R-38 (5/12 roof pitch)	0.035	0.026
R-49 (5/12 roof pitch)	0.032	0.020
Vaulted Ceilings		
	16" O.C.	24" O.C.
Vented		
R-19 2x10 joist	0.049	0.048
R-30 2x12 joist	0.034	0.033
R-38 2x14 joist	0.027	0.027

			Standard Frame	Advanced Frame
Unvented				
R-30 2x10 joist			0.034	0.033
R-38 2x12 joist			0.029	0.027
R-21 + R-21 2x12 joist			0.026	0.025
Roof Deck				
4x Beams, 48" O.C.				
R-12.5	2"	Rigid insulation	0.064	
R-21.9	3.5"	Rigid insulation	0.040	
R-37.5	6"	Rigid insulation	0.025	
R-50	8"	Rigid insulation	0.019	

Table 10-7A
Steel Truss¹ Framed Ceiling U_O

Cavity R-value	Truss Span (ft)												
	12	14	16	18	20	22	24	26	28	30	32	34	36
19	0.1075	0.0991	0.0928	0.0878	0.0839	0.0807	0.0780	0.0757	0.0737	0.0720	0.0706	0.0693	0.0681
30	0.0907	0.0823	0.0760	0.0710	0.0671	0.0638	0.0612	0.0589	0.0569	0.0552	0.0538	0.0525	0.0513
38	0.0844	0.0759	0.0696	0.0647	0.0607	0.0575	0.0548	0.0525	0.0506	0.0489	0.0474	0.0461	0.0449
49	0.0789	0.0704	0.0641	0.0592	0.0552	0.0520	0.0493	0.0470	0.0451	0.0434	0.0419	0.0406	0.0395

Table 10-7B
Steel Truss¹ Framed Ceiling U_O with R-3 Sheathing²

Cavity R-value	Truss Span (ft)												
	12	14	16	18	20	22	24	26	28	30	32	34	36
19	0.0809	0.0763	0.0728	0.0701	0.0679	0.0661	0.0647	0.0634	0.0623	0.0614	0.0606	0.0599	0.0592
30	0.0641	0.0595	0.0560	0.0533	0.0511	0.0493	0.0478	0.0466	0.0455	0.0446	0.0438	0.0431	0.0424
38	0.0577	0.0531	0.0496	0.0469	0.0447	0.0430	0.0415	0.0402	0.0392	0.0382	0.0374	0.0367	0.0361
49	0.0523	0.0476	0.0441	0.0414	0.0393	0.0375	0.0360	0.0348	0.0337	0.0328	0.0319	0.0312	0.0306

Table 10-7C
Steel Truss¹ Framed Ceiling U_O with R-5 Sheathing²

Cavity R-value	Truss Span (ft)												
	12	14	16	18	20	22	24	26	28	30	32	34	36
19	0.0732	0.0697	0.0670	0.0649	0.0633	0.0619	0.0608	0.0598	0.0590	0.0583	0.0577	0.0571	0.0567
30	0.0564	0.0529	0.0502	0.0481	0.0465	0.0451	0.0440	0.0430	0.0422	0.0415	0.0409	0.0403	0.0399
38	0.0501	0.0465	0.0438	0.0418	0.0401	0.0388	0.0376	0.0367	0.0359	0.0351	0.0345	0.0340	0.0335
49	0.0446	0.0410	0.0384	0.0363	0.0346	0.0333	0.0322	0.0312	0.0304	0.0297	0.0291	0.0285	0.0280

Table 10-7D
Steel Truss¹ Framed Ceiling U_O with R-10 Sheathing²

Cavity R-value	Truss Span (ft)												
	12	14	16	18	20	22	24	26	28	30	32	34	36
19	0.0626	0.0606	0.0590	0.0578	0.0569	0.0561	0.0555	0.0549	0.0545	0.0541	0.0537	0.0534	0.0531
30	0.0458	0.0437	0.0422	0.0410	0.0401	0.0393	0.0387	0.0381	0.0377	0.0373	0.0369	0.0366	0.0363
38	0.0394	0.0374	0.0359	0.0347	0.0337	0.0330	0.0323	0.0318	0.0313	0.0309	0.0305	0.0302	0.0299
49	0.0339	0.0319	0.0304	0.0292	0.0283	0.0275	0.0268	0.0263	0.0258	0.0254	0.0251	0.0247	0.0245

Table 10-7E
Steel Truss¹ Framed Ceiling U_O with R-15 Sheathing²

Cavity R-value	Truss Span (ft)												
	12	14	16	18	20	22	24	26	28	30	32	34	36
19	0.0561	0.0550	0.0541	0.0535	0.0530	0.0526	0.0522	0.0519	0.0517	0.0515	0.0513	0.0511	0.0509
30	0.0393	0.0382	0.0373	0.0367	0.0362	0.0358	0.0354	0.0351	0.0349	0.0347	0.0345	0.0343	0.0341
38	0.0329	0.0318	0.0310	0.0303	0.0298	0.0294	0.0291	0.0288	0.0285	0.0283	0.0281	0.0279	0.0278
49	0.0274	0.0263	0.0255	0.0249	0.0244	0.0239	0.0236	0.0233	0.0230	0.0228	0.0226	0.0225	0.0223

- 1 - Assembly values based on 24 inch on center truss spacing; 11 Truss member connections penetrating insulation (4 at the eaves, 7 in the interior space); 1/2 inch drywall ceiling; all truss members are 2x4 "C" channels with a solid web.
- 2 - Ceiling sheathing installed between bottom chord and drywall.

[Statutory Authority: RCW 19.27A.025, 19.27A.045, 01-03-010, § 51-11-1007, filed 1/5/01, effective 7/1/01; 98-03-003, § 51-11-1007, filed 1/8/98, effective 7/1/98. Statutory Authority: RCW 19.27A.020 and 1990 c 2, 91-01-112, § 51-11-1007, filed 12/19/90, effective 7/1/91.]

WAC 51-11-1008 Section 1008 Air infiltration.

1008.1 General: Tables 10-8 and 10-8A list effective air change rates and heat capacities for heat loss due to infiltration for Group R Occupancy.

Estimated seasonal average infiltration rate in air changes per hour (ACH) is given for standard air-leakage control (see section 502.4 of this code for air leakage requirements for Group R Occupancy). The effective air-change rate shall be used in calculations for compliance under either the Component Performance or Systems Analysis approaches.

Heat loss due to infiltration shall be computed using the following equation:

$$Q_{infil} = ACH_{eff} * HCP$$

- where:
- Q_{infil} = Heat loss due to air infiltration
 - ACH_{eff} = the effective air infiltration rate in Table 10-8
 - HCP = the Heat Capacity Density Product for the appropriate elevation or climate zone as given below.

**TABLE 10-8
ASSUMED EFFECTIVE AIR CHANGES
PER HOUR**

Air-Leakage Control Package	Air Changes per Hour	
	Natural	Effective
Standard	0.35	0.35

**TABLE 10-8A
DEFAULT HEAT CAPACITY/DENSITY PRODUCT
FOR AIR**

Zone	Average Elevation	Heat Capacity/Density
1	Mean Sea Level	0.0180 Btu/h•°F
2	2000	0.0168 Btu/h•°F
3	3000	0.0162 Btu/h•°F

[Statutory Authority: RCW 19.27A.025, 19.27A.045, 01-03-010, § 51-11-1008, filed 1/5/01, effective 7/1/01; 98-03-003, § 51-11-1008, filed 1/8/98, effective 7/1/98. Statutory Authority: RCW 19.27A.020 and 1990 c 2. 91-01-112, § 51-11-1008, filed 12/19/90, effective 7/1/91.]

WAC 51-11-1009 Section 1009 Mass.

1009.1 General: Tables 10-9 and 10-10 list default mass values for concrete masonry construction. Calculations are based on standard ASHRAE values for heat-storage capacity as listed in Standard RS-27, Chapter 24.

Thermal capacity of furniture is ignored, as is heat storage beyond the first four inches of mass thickness. All mass is assumed to be in direct contact with the conditioned space. Concrete separated from the heated volume by other materials must multiply the listed concrete mass value by the result of the following formula:

$$\ln(R\text{-value}) \times (-.221) + 0.5$$

Where:

Ln = Natural log

R-value = R-value of material covering concrete

Note: All default values for covered concrete slabs have been adjusted according to this procedure.

1009.2 Mass Description: Mass is divided into two types: Structural and additional.

Structural Mass: Includes heat-storage capacity of all standard building components of a typical residential structure, including floors, ceilings, and interior and exterior walls in Btu/ft²•°F of floor area. It also assumes exterior wall, interior wall and ceiling surface area approximately equals three times the floor area.

Additional Mass: Includes any additional building material not part of the normal structure, which is added specifically to increase the building's thermal-storage capability. This category includes masonry fireplaces, water or trombe walls, and extra layers of sheetrock. Coefficients are in Btu/ft²•°F of surface area of material exposed to conditioned space. The coefficient for water is Btu/°F•gallon.

1009.3 Component Description: Light frame assumes one inch thick wood flooring with five-eighths inch sheetrock on ceilings and interior walls, and walls consisting of either five-eighths inch sheetrock or solid logs. Slab assumes a four-inch concrete slab on or below grade, with five-eighths inch sheetrock on exterior and interior walls and ceiling, and with separate values for interior or exterior wall insulation. Adjustments for slab covering is based on R-value of material. Additional mass values are based on the density multiplied by the specific heat of the material adjusted for listed thickness.

**TABLE 10-9
HEAT CAPACITY**

	Partial Grout	Solid Grout
8" CMU	9.65	15.0
12" CMU	14.5	23.6
8" Brick	10.9	16.4
6" Concrete	NA	14.4

**TABLE 10-10
DEFAULT MASS VALUES**

Structural Mass M-value	Btu/ft²•°F floor area
Light Frame: Joisted/post & beam floor, sheetrock walls and ceilings	3.0
Joisted/post & beam floor, log walls,	

Structural Mass M-value	Btu/ft ² •°F floor area
sheetrock ceilings	4.0
Slab With Interior Wall Insulation:	
Slab, no covering or tile, sheetrock walls and ceilings	10.0
Slab, hardwood floor covering, sheetrock walls and ceilings	7.0
Slab, carpet and pad, sheetrock walls and ceilings	5.0
Slab With Exterior Wall Insulation:	
Slab, no covering or tile, sheetrock walls and ceilings	12.0
Slab, hardwood floor covering, sheetrock walls and ceilings	9.0
Slab, carpet and pad, sheetrock walls and ceilings	7.0
Additional Mass M-Value:	
Btu/ft²•°F surface area	
Gypsum wallboard, 1/2 inch thickness	0.54
Gypsum wallboard, 5/8 inch thickness	0.68
Hardwood floor	1.40
Concrete/Brick, 4 inch-thickness	10.30
Concrete/Brick, 6 inch-thickness	15.40
Btu/°F•gallon	
Water, 1 gallon	8.0

[Statutory Authority: RCW 19.27A.025, 19.27A.045, 01-03-010, § 51-11-1009, filed 1/5/01, effective 7/1/01; 98-03-003, § 51-11-1009, filed 1/8/98, effective 7/1/98. Statutory Authority: RCW 19.27A.020 and 1990 c 2. 91-01-112, § 51-11-1009, filed 12/19/90, effective 7/1/91.]

**CHAPTER 11
ADMINISTRATION AND ENFORCEMENT**

WAC 51-11-1100 Title. Chapters 11 through 20 of this Code shall be known as the "Washington State Nonresidential Energy Code" and may be cited as such; and will be referred to hereafter as "this Code."

[Statutory Authority: RCW 19.27A.025, 93-21-052, § 51-11-1100, filed 10/18/93, effective 4/1/94.]

WAC 51-11-1110 Purpose and intent. The purpose of this Code is to provide minimum standards for new or altered buildings and structures or portions thereof to achieve efficient use and conservation of energy. It is intended that these provisions provide flexibility to permit the use of innovative approaches and techniques to achieve efficient use and conservation of energy.

The purpose of this Code is not to create or otherwise establish or designate any particular class or group of persons who will or should be especially protected or benefitted by the terms of this Code. This Code is not intended to abridge any safety or health requirements required under any other applicable codes or ordinances.

The provisions of this Code do not consider the efficiency of various energy forms as they are delivered to the building envelope.

[Statutory Authority: RCW 19.27A.025, 93-21-052, § 51-11-1110, filed 10/18/93, effective 4/1/94.]

WAC 51-11-1120 Scope. This Code sets forth minimum requirements for the design of new or altered buildings

and structures or portions thereof that provide facilities or shelter for public assembly, educational, business, mercantile, institutional, storage, factory, and industrial occupancies by regulating their exterior envelopes and the selection of their HVAC, service water heating, electrical distribution and illuminating systems and equipment for efficient use and conservation of energy.

EXCEPTION: The provisions of this code do not apply to temporary growing structures used solely for the commercial production of horticultural plants including ornamental plants, flowers, vegetables, and fruits. "Temporary growing structure" means a structure that has the sides and roof covered with polyethylene, polyvinyl, or similar flexible synthetic material and is used to provide plants with either frost protection or increased heat retention. A temporary growing structure is not considered a building for purposes of this code.

[Statutory Authority: RCW 19.27A.025 and 19.27A.045, 98-03-003, § 51-11-1120, filed 1/8/98, effective 7/1/98. Statutory Authority: RCW 19.27A.025, 93-21-052, § 51-11-1120, filed 10/18/93, effective 4/1/94.]

WAC 51-11-1130 Application to existing buildings. Additions, alterations or repairs, changes of occupancy or use, or historic buildings that do not comply with the requirements for new buildings, shall comply with the requirements in Sections 1130 through 1134 as applicable.

EXCEPTION: The building official may approve designs of alterations or repairs which do not fully conform with all of the requirements of Sections 1130 through 1134 where in the opinion of the building official full compliance is physically impossible and/or economically impractical and the alteration or repair improves the energy efficiency of the building.

In no case shall energy code requirements be less than those requirements in effect at the time of the initial construction of the building.

[Statutory Authority: RCW 19.27A.025 and 19.27A.045, 98-03-003, § 51-11-1130, filed 1/8/98, effective 7/1/98. Statutory Authority: RCW 19.27A.025, 93-21-052, § 51-11-1130, filed 10/18/93, effective 4/1/94.]

WAC 51-11-1131 Additions to existing buildings. Additions to existing buildings or structures may be constructed without making the entire building or structure comply, provided that the new additions shall conform to the provisions of this Code.

EXCEPTION: New additions which do not fully comply with the requirements of this Code and which have a floor area which is less than seven hundred fifty square feet may be approved provided that improvements are made to the existing building to compensate for any deficiencies in the new addition. Compliance shall be demonstrated by either systems analysis per Section 1141.4 or component performance calculations per Sections 1330 through 1334. The nonconforming addition and upgraded, existing building shall have an energy budget or target UA and SHGC that are less than or equal to the unimproved existing building, with the addition designed to comply with this Code.

[Statutory Authority: RCW 19.27A.025, 93-21-052, § 51-11-1131, filed 10/18/93, effective 4/1/94.]

WAC 51-11-1132 Alterations and repairs. Alterations and repairs to buildings or portions thereof originally constructed subject to the requirements of this Code shall conform to the provisions of this Code without the use of the exception in Section 1130. Other alterations and repairs may be made to existing buildings and moved buildings without making the entire building comply with all of the requirements of this Code for new buildings, provided the following requirements are met:

1132.1 Building Envelope: Alterations or repairs shall comply with nominal R-values and glazing requirements in Table 13-1 or 13-2.

EXCEPTIONS:

1. Storm windows installed over existing glazing.
2. Glass replaced in existing sash and frame provided that glazing is of equal or lower U-factor.
3. For solar heat gain coefficient compliance, glazing with a solar heat gain coefficient equal to or lower than that of the other existing glazing.
4. Existing roof/ceiling, wall or floor cavities exposed during construction provided that these cavities are insulated to full depth with insulation having a minimum nominal value of R-3.0 per inch installed per Sections 1311 and 1313.
5. Existing walls and floors without framing cavities, provided that any new cavities added to existing walls and floors comply with Exception 4.
6. Existing roofs where the roof membrane is being replaced and
 - a. The roof sheathing or roof insulation is not exposed; or
 - b. If there is existing roof insulation below the deck.

In no case shall the energy efficiency of the building be decreased.

1132.2 Building Mechanical Systems: Those parts of systems which are altered or replaced shall comply with Chapter 14 of this Code.

1132.3 Lighting and Motors: Tenant improvements, alterations or repairs where 60 percent or more of the fixtures in a use (as defined in Table 15-1) within a tenant space or in an entire floor (whichever is smaller) are new shall comply with Sections 1531 and 1532. Where less than 60 percent of the fixtures are new, the installed lighting wattage shall be maintained or reduced. Where 60 percent or more of the lighting fixtures in a suspended ceiling are new, and the existing insulation is on the suspended ceiling, the roof/ceiling assembly

shall be insulated according to the provisions of Chapter 13 Section 1311.2.

Where new wiring is being installed to serve added fixtures and/or fixtures are being relocated to a new circuit, controls shall comply with Sections 1513.1 through 1513.5. Where a new lighting panel (or a moved lighting panel) with all new raceway and conductor wiring from the panel to the fixtures is being installed, controls shall comply with Section 1513.6.

Those motors which are altered or replaced shall comply with Section 1511.

[Statutory Authority: RCW 19.27A.025, 19.27A.045, 01-03-010, § 51-11-1132, filed 1/5/01, effective 7/1/01; 98-03-003, § 51-11-1132, filed 1/8/98, effective 7/1/98. Statutory Authority: RCW 19.27A.025, 93-21-052, § 51-11-1132, filed 10/18/93, effective 4/1/94.]

WAC 51-11-1133 Change of occupancy or use. Changes of occupancy or use shall comply with the following requirements:

a. Any unconditioned space that is altered to become semi-heated, cooled, or fully heated, or any semi-heated space that is altered to become cooled or fully heated space shall be required to be brought into full compliance with this Code.

b. Any Group R Occupancy which is converted to other than a Group R Occupancy shall be required to comply with all of the provisions of Sections 1130 through 1132 of this Code.

[Statutory Authority: RCW 19.27A.025 and 19.27A.045, 98-03-003, § 51-11-1133, filed 1/8/98, effective 7/1/98. Statutory Authority: RCW 19.27A.025, 93-21-052, § 51-11-1133, filed 10/18/93, effective 4/1/94.]

WAC 51-11-1134 Historic buildings. The building official may modify the specific requirements of this Code for historic buildings and require in lieu thereof alternate requirements which will result in a reasonable degree of energy efficiency. This modification may be allowed for those buildings which have been specifically designated as historically significant by the state or local governing body, or listed in The National Register of Historic Places or which have been determined to be eligible for listing.

[Statutory Authority: RCW 19.27A.025, 93-21-052, § 51-11-1134, filed 10/18/93, effective 4/1/94.]

WAC 51-11-1140 Enforcement. The building official shall have the power to render interpretations of this code and to adopt and enforce rules and supplemental regulations in order to clarify the application of its provisions. Such interpretations, rules and regulations shall be in conformance with the intent and purpose of this Code. Fees may be assessed for enforcement of this Code and shall be as set forth in the fee schedule adopted by the jurisdictions.

[Statutory Authority: RCW 19.27A.025, 93-21-052, § 51-11-1140, filed 10/18/93, effective 4/1/94.]

WAC 51-11-1141 Plans and specifications.

1141.1 General: If required by the building official, plans and specifications shall be submitted in support of an applica-

tion for a building permit. If required by the building official, plans and specifications shall be stamped and authenticated by a registered design professional currently licensed in the state of Washington. All plans and specifications, together with supporting data, shall be submitted to the building official prior to issuance of a building permit.

1141.2 Details: The plans and specifications shall show in sufficient detail all pertinent data and features of the building and the equipment and systems as herein governed including, but not limited to: Design criteria; exterior envelope component materials, U-factors of the envelope systems, R-values of insulating materials; U-factors and shading coefficients of glazing; area weighted U-factor calculations; efficiency, economizer, size and type of apparatus and equipment; fan system horsepower; equipment and systems controls; lighting fixture schedule with wattages and controls narrative; and other pertinent data to indicate compliance with the requirements of this Code.

1141.3 Alternate Materials and Method of Construction: The provisions of this Code are not intended to prevent the use of any material, method of construction, design or insulating system not specifically prescribed herein, provided that such construction, design or insulating system has been approved by the building official as meeting the intent of this Code. The building official may approve any such alternate provided the proposed alternate meets or exceeds the provisions of this Code and that the material, method, design or work offered is for the purpose intended, at least the equivalent of that prescribed in this Code, in quality, strength, effectiveness, fire-resistance, durability, safety, and energy efficiency. The building official may require that sufficient evidence of proof be submitted to substantiate any claims that may be made regarding performance capabilities.

1141.4 Systems Analysis Approach for the Entire Building: In lieu of using Chapters 12 through 20, compliance may be demonstrated using the systems analysis option in RS-29. When using systems analysis, the proposed building shall provide equal or better conservation of energy than the standard design as defined in RS-29. If required by the building official, all energy comparison calculations submitted under the provisions of RS-29 shall be stamped and authenticated by an engineer or architect licensed to practice by the state of Washington.

[Statutory Authority: RCW 19.27A.025. 93-21-052, § 51-11-1141, filed 10/18/93, effective 4/1/94.]

WAC 51-11-1142 Materials and equipment.

1142.1 Identification: All materials and equipment shall be identified in order to show compliance with this Code.

1142.2 Maintenance Information: Maintenance instructions shall be furnished for any equipment which requires preventive maintenance for efficient operation. Required regular maintenance actions shall be clearly stated and incorporated on a readily accessible label. Such label may be limited to identifying, by title or publication number, the operation and maintenance manual for that particular model and type of product.

(2003 Ed.)

[Statutory Authority: RCW 19.27A.025. 93-21-052, § 51-11-1142, filed 10/18/93, effective 4/1/94.]

WAC 51-11-1143 Inspections.

1143.1 General: All construction or work for which a permit is required shall be subject to inspection by the building official and all such construction or work shall remain accessible and exposed for inspection purposes until approved by the building official. No work shall be done on any part of the building or structure beyond the point indicated in each inspection without first obtaining the approval of the building official.

1143.2 Required Inspections: The building official, upon notification, shall make the inspection required in this Section, in addition to or as part of those inspections required in Section 108.5 of the Uniform Building Code. Inspections may be conducted by special inspection pursuant to Section 1701 of the Uniform Building Code. Where applicable, inspections shall include at least:

1143.2.1 Envelope

a. Wall Insulation Inspection: To be made after all wall insulation and air vapor retarder sheet or film materials are in place, but before any wall covering is placed.

b. Glazing Inspection: To be made after glazing materials are installed in the building.

c. Exterior Roofing Insulation: To be made after the installation of the roof insulation, but before concealment.

d. Slab/Floor Insulation: To be made after the installation of the slab/floor insulation, but before concealment.

1143.2.2 Mechanical

a. Mechanical Equipment Efficiency and Economizer: To be made after all equipment and controls required by this Code are installed and prior to the concealment of such equipment or controls.

b. Mechanical Pipe and Duct Insulation: To be made after all pipe and duct insulation is in place, but before concealment.

1143.2.3 Lighting and Motors

a. Lighting Equipment and Controls: To be made after the installation of all lighting equipment and controls required by this Code, but before concealment of the lighting equipment.

b. Motor Inspections: To be made after installation of all equipment covered by this Code, but before concealment.

1143.3 Reinspection: The building official may require a structure to be reinspected. A reinspection fee may be assessed for each inspection or reinspection when such portion of work for which inspection is called is not complete or when corrections called for are not made.

[Statutory Authority: Chapters 19.27 and 19.27A RCW and 1994 c 226: 95-01-126, § 51-11-1143, filed 12/21/94, effective 6/30/95. Statutory Authority: RCW 19.27A.025. 93-21-052, § 51-11-1143, filed 10/18/93, effective 4/1/94.]

WAC 51-11-1144 Violations. It shall be a violation of this Code for any person, firm, or corporation to erect or construct any building, or remodel or rehabilitate any existing

[Title 51 WAC—p. 71]

building or structure in the state, or allow the same to be done, contrary to any of the provisions of this Code.

[Statutory Authority: RCW 19.27A.025. 93-21-052, § 51-11-1144, filed 10/18/93, effective 4/1/94.]

WAC 51-11-1150 Conflicts with other codes. In case of conflicts among Codes enumerated in RCW 19.27.031 (1), (2), (3) and (4) and this Code, the first named Code shall govern. The duct insulation requirements in this Code or a local jurisdiction's energy code, whichever is more stringent, supersede the requirements in the Uniform Mechanical Code.

Where, in any specific case, different sections of this Code specify different materials, methods of construction or other requirements, the most restrictive shall govern. Where there is a conflict between a general requirement and a specific requirement, the specific requirement shall be applicable.

[Statutory Authority: RCW 19.27A.025. 93-21-052, § 51-11-1150, filed 10/18/93, effective 4/1/94.]

WAC 51-11-1160 Severability and liability.

1161 Severability: If any provision of this Code or its application to any person or circumstance is held invalid, the remainder of this Code or the application of the provision to other persons or circumstances is not affected.

1162 Liability: Nothing contained in this Code is intended to be nor shall be construed to create or form the basis for any liability on the part of any city or county or its officers, employees or agents for any injury or damage resulting from the failure of a building to conform to the provisions of this Code.

[Statutory Authority: RCW 19.27A.025. 93-21-052, § 51-11-1160, filed 10/18/93, effective 4/1/94.]

CHAPTER 12 DEFINITIONS

Note: For nonresidential definitions, see Chapter 2.

CHAPTER 13 BUILDING ENVELOPE

WAC 51-11-1301 Scope. Conditioned buildings or portions thereof shall be constructed to provide the required thermal performance of the various components according to the requirements of this chapter. Unless otherwise approved by the building official, all spaces shall be assumed to be at least semi-heated.

EXCEPTION

1. Greenhouses isolated from any conditioned space and not intended for occupancy.
2. As approved by the building official, spaces not assumed to be at least semi-heated.
3. Unconditioned Group U Occupancy accessory to Group R Occupancy.
4. Unstaffed equipment shelters or cabinets used solely for personal wireless service facilities.

[Statutory Authority: RCW 19.27.074, 19.27A.020 and 19.27A.025. 97-03-017, § 51-11-1301, filed 1/7/97, effective 7/1/97. Statutory Authority: RCW 19.27A.025. 93-21-052, § 51-11-1301, filed 10/18/93, effective 4/1/94.]

[Title 51 WAC—p. 72]

WAC 51-11-1302 Space heat type. For the purpose of determining building envelope requirements, the following two categories comprise all space heating types:

Electric Resistance: Space heating systems which use electric resistance elements as the primary heating systems including baseboard, radiant, and forced air units where the total electric resistance heat capacity exceeds one watt per square foot of the gross conditioned floor area.

EXCEPTION: Heat pumps and terminal electric resistance heating in variable air volume distribution systems.

Other: All other space heating systems including gas, solid fuel, oil, and propane space heating systems and those systems listed in the exception to electric resistance.

[Statutory Authority: RCW 19.27A.025. 93-21-052, § 51-11-1302, filed 10/18/93, effective 4/1/94.]

WAC 51-11-1303 Climate zones. All buildings shall comply with the requirements of the appropriate climate zone as defined herein.

- ZONE 1:** Climate Zone 1 shall include all counties not included in Climate Zone 2.
- ZONE 2:** Climate Zone 2 shall include: Adams, Chelan, Douglas, Ferry, Grant, Kittitas, Lincoln, Okanogan, Pend Oreille, Spokane, Stevens, and Whitman counties.

[Statutory Authority: RCW 19.27A.025. 93-21-052, § 51-11-1303, filed 10/18/93, effective 4/1/94.]

WAC 51-11-1310 General requirements. The building envelope shall comply with Sections 1311 through 1314.

1310.1 Conditioned Spaces: The building envelope for conditioned spaces shall also comply with one of the following paths:

- a. Prescriptive Building Envelope Option Sections 1320 through 1323.
- b. Component Performance Building Envelope Option Sections 1330 through 1334.
- c. Systems Analysis. See Section 1141.4.

1310.2 Semi-Heated Spaces: All spaces shall be considered conditioned spaces, and shall comply with the requirements in Section 1310.1 unless they meet the following criteria for semi-heated spaces. The installed heating equipment output, in Climate Zone 1, shall be 3 Btu/(h•ft²) or greater but not greater than 8 Btu/(h•ft²) and in Climate Zone 2, shall be 5 Btu/(h•ft²) or greater but not greater than 12 Btu/(h•ft²). Heating shall be controlled by a thermostat mounted not lower than the heating unit and capable of preventing heating above 44 degrees space temperature. For semi-heated spaces, the only prescriptive, component performance, or systems analysis building envelope requirement shall be that:

Climate Zone 1

- a. U = 0.10 maximum for the roof assembly, or
- b. continuous R-9 insulation installed entirely outside of the roof structure, or
- c. R-11 insulation installed inside or within a wood roof structure, or

- d. R-19 insulation installed inside or within a metal roof structure.

Climate Zone 2

- a. U = 0.07 maximum for the roof assembly, or
- b. continuous R-14 insulation installed entirely outside of the roof structure, or
- c. R-19 insulation installed inside or within a wood roof structure, or
- d. R-25 insulation installed inside or within a metal roof structure.

Figure 13A
Building Envelope Compliance Options

Section Number	Subject	Prescriptive Option	Component Performance Option	Systems Analysis Option
1310	General Requirements	X	X	X
1311	Insulation	X	X	X
1312	Glazing and Doors	X	X	X
1313	Moisture Control	X	X	X
1314	Air Leakage	X	X	X
1320	Prescriptive Building Envelope Option	X		
1321	General	X		
1322	Opaque Envelope	X		
1323	Glazing	X		
1330	Component Performance Building Envelope Option		X	
1331	General		X	
1332	Component U-Factors		X	
1333	UA Calculations		X	
1334	Solar Heat Gain Coefficient		X	
RS-29	Systems Analysis			X

[Statutory Authority: RCW 19.27A.025. 93-21-052, § 51-11-1310, filed 10/18/93, effective 4/1/94.]

WAC 51-11-1311 Insulation.

1311.1 Installation Requirements: All insulation materials shall be installed according to the manufacturer's instructions to achieve proper densities, maintain clearances, and maintain uniform R-values. To the maximum extent possible, insulation shall extend over the full component area to the intended R-value.

1311.2 Roof/Ceiling Insulation: Open-blown or poured loose-fill insulation may be used in attic spaces where the slope of the ceiling is not more than three feet in twelve and there is at least thirty inches of clear distance from the top of the bottom chord of the truss or ceiling joist to the underside of the sheathing at the roof ridge. When eave vents are installed, baffling of the vent openings shall be provided so as to deflect the incoming air above the surface of the insulation.

Where lighting fixtures are recessed into a suspended or exposed grid ceiling, the roof/ceiling assembly shall be insulated in a location other than directly on the suspended ceiling.

EXCEPTION: Type IC rated recessed lighting fixtures.

Where installed in wood framing, faced batt insulation shall be face stapled.

1311.3 Wall Insulation: Exterior wall cavities isolated during framing shall be fully insulated to the levels of the surrounding walls. When installed in wood framing, faced batt insulation shall be face stapled.

Above grade exterior insulation shall be protected.

1311.4 Floor Insulation: Floor insulation shall be installed in a permanent manner in substantial contact with the surface being insulated. Insulation supports shall be installed so spacing is not more than twenty-four inches on center. Installed insulation shall not block the airflow through foundation vents.

1311.5 Slab-On-Grade Floor: Slab-on-grade insulation installed inside the foundation wall shall extend downward from the top of the slab a minimum distance of twenty-four inches or to the top of the footing, whichever is less. Insulation installed outside the foundation shall extend downward a minimum of twenty-four inches or to the frostline, whichever is greater. Above grade insulation shall be protected.

EXCEPTION: For monolithic slabs, the insulation shall extend downward from the top of the slab to the bottom of the footing.

1311.6 Radiant Floors (on or below grade): Slab-on-grade insulation shall extend downward from the top of the slab a minimum distance of thirty-six inches or downward to the top of the footing and horizontal for an aggregate of not less than thirty-six inches.

If required by the building official where soil conditions warrant such insulation, the entire area of a radiant floor shall be thermally isolated from the soil. Where a soil gas control system is provided below the radiant floor, which results in increased convective flow below the radiant floor, the radiant floor shall be thermally isolated from the sub-floor gravel layer.

[Statutory Authority: RCW 19.27A.025. 93-21-052, § 51-11-1311, filed 10/18/93, effective 4/1/94.]

WAC 51-11-1312 Glazing and doors.

1312.1 Standard Procedure for Determination of Glazing and Door U-Factors: U-Factors for glazing and doors shall be determined, certified and labeled in accordance with Standard RS-31 by a certified independent agency licensed by the National Fenestration Rating Council (NFRC). Compliance shall be based on the Residential or the Nonresidential Model Size. Product samples used for U-factor determinations shall be production line units or representative of units as purchased by the consumer or contractor. Unlabeled glazing and doors shall be assigned the default U-factor in Table 10-6.

1312.2 Solar Heat Gain Coefficient and Shading Coefficient: Solar Heat Gain Coefficient (SHGC), shall be determined, certified and labelled in accordance with the National Fenestration Rating Council (NFRC) Standard by a certified, independent agency, licensed by the NFRC.

EXCEPTION: Shading coefficients (SC) shall be an acceptable alternate for compliance with solar heat gain coefficient requirements. Shading coefficients for glazing shall be taken from Chapter 29 of RS-27 or from the manufacturer's test data.

[Statutory Authority: RCW 19.27A.025, 19.27A.045. 01-03-010, § 51-11-1312, filed 1/5/01, effective 7/1/01; 98-03-003, § 51-11-1312, filed 1/8/98, effective 7/1/98. Statutory Authority: RCW 19.27A.025. 93-21-052, § 51-11-1312, filed 10/18/93, effective 4/1/94.]

WAC 51-11-1313 Moisture control.

1313.1 Vapor Retarders: Vapor retarders shall be installed on the warm side (in winter) of insulation as required by this section.

EXCEPTION: Vapor retarder installed with not more than 1/3 of the nominal R-value between it and the conditioned space.

1313.2 Roof/Ceiling Assemblies: Roof/ceiling assemblies where the ventilation space above the insulation is less than an average of twelve inches shall be provided with a vapor retarder. (For enclosed attics and enclosed rafter spaces see Section 1505.3 of the Washington State Building Code.) Roof/ceiling assemblies without a vented airspace, allowed only where neither the roof deck nor the roof structure are made of wood, shall provide a continuous vapor retarder with taped seams.

EXCEPTION: Vapor retarders need not be provided where all of the insulation is installed between the roof membrane and the structural roof deck.

1313.3 Walls: Walls separating conditioned space from unconditioned space shall be provided with a vapor retarder.

1313.4 Floors: Floors separating conditioned space from unconditioned space shall be provided with a vapor retarder.

1313.5 Crawl Spaces: A ground cover of six mil (0.006 inch thick) black polyethylene or approved equal shall be laid over the ground within crawl spaces. The ground cover shall be overlapped twelve inches minimum at the joints and shall extend to the foundation wall.

EXCEPTION: The ground cover may be omitted in crawl spaces if the crawl space has a concrete slab floor with a minimum thickness of three and one-half inches.

[Statutory Authority: RCW 19.27A.025, 19.27A.045. 01-03-010, § 51-11-1313, filed 1/5/01, effective 7/1/01. Statutory Authority: RCW 19.27A.025. 93-21-052, § 51-11-1313, filed 10/18/93, effective 4/1/94.]

WAC 51-11-1314 Air leakage.

1314.1 Building Envelope: The requirements of this section shall apply to building elements separating conditioned from unconditioned spaces. Exterior joints around windows and door frames, openings between walls and foundation, between walls and roof and wall panels; openings at penetrations of utility services through walls, floors, and roofs; and all other openings in the building envelope shall be sealed, caulked, gasketed, or weatherstripped to limit air leakage.

1314.2 Glazing and Doors: Doors and operable glazing separating conditioned from unconditioned space shall be weatherstripped. Fixed windows shall be tight fitting with glass retained by stops with sealant or caulking all around.

EXCEPTION: Openings that are required to be fire resistant.

1314.3 Building Assemblies Used as Ducts or Plenums: Building assemblies used as ducts or plenums shall be sealed, caulked, and gasketed to limit air leakage.

[Title 51 WAC—p. 74]

[Statutory Authority: RCW 19.27A.025. 93-21-052, § 51-11-1314, filed 10/18/93, effective 4/1/94.]

WAC 51-11-1320 Prescriptive building envelope option.

[Statutory Authority: RCW 19.27A.025. 93-21-052, § 51-11-1320, filed 10/18/93, effective 4/1/94.]

WAC 51-11-1321 General. This section establishes building envelope design criteria in terms of prescribed requirements for building construction.

[Statutory Authority: RCW 19.27A.025. 93-21-052, § 51-11-1321, filed 10/18/93, effective 4/1/94.]

WAC 51-11-1322 Opaque envelope. Roof/ceilings, opaque exterior walls, opaque doors, floors over unconditioned space, below grade walls, slab on grade floors, and radiant floors enclosing conditioned spaces shall be insulated according to Section 1311 and Tables 13-1 or 13-2. Compliance with nominal R-values shall be demonstrated for the thermal resistance of the added insulation in framing cavities and/or insulated sheathing only. Nominal R-values shall not include the thermal transmittance of other building materials or air films.

For metal frame assemblies used in spaces with electric resistance space heat, compliance shall be demonstrated with the component U-factor for the overall assembly based on the assemblies in Chapter 10.

EXCEPTIONS:

1. Opaque smoke vents are not required to meet insulation requirements.
2. The perimeter edge of an above grade floor slab which penetrates the exterior wall may be left uninsulated provided that the wall insulation is increased by R-2 above that required in Tables 13-1 and 13-2.

[Statutory Authority: RCW 19.27A.025, 19.27A.045. 01-03-010, § 51-11-1322, filed 1/5/01, effective 7/1/01. Statutory Authority: RCW 19.27A.025. 93-21-052, § 51-11-1322, filed 10/18/93, effective 4/1/94.]

WAC 51-11-1323 Glazing. Glazing shall comply with Section 1312 and Tables 13-1 or 13-2. All glazing shall be, at a minimum, double glazing.

EXCEPTIONS:

1. Vertical glazing located on the display side of the street level story of a retail occupancy provided the glazing
 - a. is double-glazed with a minimum 1/2 inch airspace and with a low-e coating having a maximum emittance of e-0.40 or has an area weighted U-factor of 0.60 or less. (When this exception is used, there are no SHGC requirements) and,
 - b. does not exceed 75 percent of the gross exterior wall area of the display side of the street level story. However, if the display side of the street level story exceeds 20 feet in height, then this exception may only be used for the first 20 feet of that story. When this exception is utilized, separate calculations shall be performed for these sections of the building envelope and these values shall not be averaged with any others for compliance purposes. The 75 percent area may be exceeded on the street level, if the additional glass area is provided from allowances from other areas of the building.
2. Single glazing for ornamental, security, or architectural purposes shall be included in the percentage of the total glazing area, U-factor calculation and SHGC as allowed in the Tables 13-1 or 13-2. The maximum area allowed for the total of all single glazing is one percent of the gross exterior wall floor area.

1323.1 Area: The percentage of total glazing (vertical and overhead) area relative to the gross exterior wall area shall not be greater than the appropriate value from Tables 13-1 or 13-2 for the vertical glazing U-factor, overhead glazing U-factor and solar heat gain coefficient selected.

1323.2 U-Factor: The area-weighted average U-factor of vertical glazing shall not be greater than that specified in Tables 13-1 or 13-2 for the appropriate area and solar heat gain coefficient. The area-weighted average U-factor of overhead glazing shall not be greater than that specified in Tables 13-1 or 13-2 for the appropriate area and solar heat gain coefficient. U-factors for glazing shall be determined in accordance with Section 1312.

1323.3 Solar Heat Gain Coefficient: The area-weighted average solar heat gain coefficient of all glazing shall not be greater than that specified in Tables 13-1 or 13-2 for the appropriate area and U-factor.

[Statutory Authority: RCW 19.27A.025, 19.27A.045, 01-03-010, § 51-11-1323, filed 1/5/01, effective 7/1/01; 98-03-003, § 51-11-1323, filed 1/8/98, effective 7/1/98. Statutory Authority: RCW 19.27A.025, 93-21-052, § 51-11-1323, filed 10/18/93, effective 4/1/94.]

WAC 51-11-1330 Component performance building envelope option.

[Statutory Authority: RCW 19.27A.025, 93-21-052, § 51-11-1330, filed 10/18/93, effective 4/1/94.]

WAC 51-11-1331 General. Buildings or structures whose design heat loss rate (UA_p) and solar heat gain coefficient rate ($SHGC \cdot A_p$) are less than or equal to the target heat loss rate (UA_t) and solar heat gain coefficient rate ($SHGC \cdot A_t$) shall be considered in compliance with this section. The stated U-factor, F-factor or allowable area of any component assembly, listed in Tables 13-1 or 13-2, such as roof/ceiling, opaque wall, opaque door, glazing, floor over conditioned space, slab on grade floor, radiant floor or opaque floor may be increased and the U-factor or F-factor for other components decreased, provided that the total heat gain or loss for the entire building envelope does not exceed the total resulting from compliance to the U-factors, F-factors or allowable areas specified in this section.

EXCEPTION: For buildings or structures utilizing the other space heat type (including heat pumps and VAV) compliance path, for the gross opaque wall, opaque door and glazing (vertical and overhead) area only, compliance may also be shown using the ENVSTD diskette version 2.1 of ASHRAE/IESNA Standard 90.1-1989, or an approved alternative, with the following additional requirements:

1. Only the Exterior Wall Requirements portion of the ENVSTD computer program may be used under this exception.
2. Overhead glazing shall be added to vertical glazing, and shall be input as 1/4 north, 1/4 east, 1/4 south and 1/4 west facing.

3. Lighting loads shall be determined according to Table 15-1.
4. Equipment loads shall be determined from Table 3-1 of Standard RS-29.

[Statutory Authority: RCW 19.27A.025, 19.27A.045, 01-03-010, § 51-11-1331, filed 1/5/01, effective 7/1/01; 98-03-003, § 51-11-1331, filed 1/8/98, effective 7/1/98. Statutory Authority: RCW 19.27A.025, 93-21-052, § 51-11-1331, filed 10/18/93, effective 4/1/94.]

WAC 51-11-1332 Component U-factors. The U-factors for typical construction assemblies are included in Chapter 20. These values shall be used for all calculations. Where proposed construction assemblies are not represented in Chapter 20, values shall be calculated in accordance with Chapters 19-27 in RS-27 listed in Chapter 17, using the framing factors listed in Chapter 20. For envelope assemblies containing metal framing, the U-factor shall be determined by one of the following methods:

1. Results of laboratory measurements according to acceptable methods of test.
2. Standard RS-25, listed in Chapter 17, where the metal framing is bonded on one or both sides to a metal skin or covering.
3. The zone method as provided in Chapter 22 of RS-27, listed in Chapter 17.
4. Effective framing/cavity R-values as provided in Table 20-5A.

When return air ceiling plenums are employed, the roof/ceiling assembly shall:

- a. For thermal transmittance purposes, not include the ceiling proper nor the plenum space as part of the assembly; and
- b. For gross area purposes, be based upon the interior face of the upper plenum surface.

[Statutory Authority: RCW 19.27A.025, 93-21-052, § 51-11-1332, filed 10/18/93, effective 4/1/94.]

WAC 51-11-1333 UA calculations. The target UA_t and the proposed UA_p shall be calculated using Equations 13-1 and 13-2 and the corresponding areas and U-factors from Table 13-1 or 13-2. For the target UA_t calculation, the overhead glazing shall be located in roof/ceiling area and the remainder of the glazing allowed per Table 13-1 or 13-2 shall be located in the wall area.

[Statutory Authority: RCW 19.27A.025, 93-21-052, § 51-11-1333, filed 10/18/93, effective 4/1/94.]

WAC 51-11-1334 Solar heat gain coefficient rate calculations. Solar heat gain coefficient shall comply with Section 1323.3. The target $SHGCA_t$ and the proposed $SHGCA_p$ shall be calculated using Equation 13-3 and 13-4 and the corresponding areas and SHGCs from Table 13-1 or 13-2.

**Equation 13-1:
Target $UA_{[t]}$**

UA_t	=	$U_{rat}A_{rat} + U_{ograt}A_{ograt} + U_{ort}A_{ort} + U_{ogort}A_{ogort} + U_{wt}A_{wt} + U_{vgt}A_{vgt} + U_{dt}A_{dt} + U_{rt}A_{rt} + F_{st}P_{st} + U_{bgwt}A_{bgwt}$
UA_t	=	The target combined specific heat transfer of the gross roof/ceiling assembly, exterior wall and floor area.

Where:

U_{rat}	=	The thermal transmittance value for roofs over attics found in Table 13-1 or 13-2.
U_{ograt}	=	The thermal transmittance for overhead glazing found in Table 13-1 or 13-2 which corresponds to the proposed total glazing area as a percent of gross exterior wall area.
U_{ort}	=	The thermal transmittance value for other roofs found in Table 13-1 or 13-2.
U_{ogort}	=	The thermal transmittance for overhead glazing found in Table 13-1 or 13-2 which corresponds to the proposed total glazing area as a percent of gross exterior wall area.
U_{wt}	=	The thermal transmittance value for opaque walls found in Table 13-1 or 13-2.
U_{vgt}	=	The thermal transmittance value for vertical glazing found in Table 13-1 or 13-2 which corresponds to the proposed total glazing area as a percent of gross exterior wall area.
U_{dt}	=	The thermal transmittance value for opaque doors found in Table 13-1 or 13-2.
U_{ft}	=	The thermal transmittance value for floors over unconditioned space found in Table 13-1 or 13-2.
F_{st}	=	The F-factor for slab-on-grade and radiant slab floors found in Table 13-1 or 13-2.
U_{bgwt}	=	The thermal transmittance value for opaque walls found in Table 13-1 or 13-2.
A_{dt}	=	The proposed opaque door area, A_d .
A_{ft}	=	The proposed floor over unconditioned space area, A_f .
P_{st}	=	The proposed lineal feet of slab-on-grade and radiant slab floor perimeter, P_s .
A_{bgwt}	=	The proposed below grade wall area, A_{bgw} .

and;

if the total amount of glazing area as a percent of gross exterior wall area does not exceed the maximum allowed in Table 13-1 or 13-2:

A_{rat}	=	The proposed roof over attic area, A_{ra} .
A_{ograt}	=	The proposed overhead glazing area in roofs over attics, A_{ogra} .
A_{ort}	=	The proposed other roof area, A_{or} .
A_{ogort}	=	The proposed overhead glazing area in other roofs, A_{ogor} .
A_{wt}	=	The proposed opaque above grade wall area, A_w .
A_{vgt}	=	The proposed vertical glazing area, A_{vg} .

or;

if the total amount of glazing area as a percent of gross exterior wall area exceeds the maximum allowed in Table 13-1 or 13-2:

A_{rat}	=	The greater of: the proposed roof over attic area, and the gross roof over attic area minus A_{ograt} .
A_{ograt}	=	The lesser of: proposed overhead glazing area in roofs over attics, and the maximum allowed glazing area from Table 13-1 or 13-2.
A_{ort}	=	The greater of: the proposed other roof area, and the gross other roof area minus A_{ogort} .
A_{ogort}	=	The lesser of: the proposed overhead glazing area in other roofs, and the maximum allowed glazing area from Table 13-1 or 13-2 minus A_{ograt} .
A_{wt}	=	The greater of: proposed opaque above grade wall area, and the gross exterior above grade wall area minus A_{dt} minus A_{vgt} .
A_{vgt}	=	The lesser of: the proposed vertical glazing area, and the maximum allowed glazing area from Table 13-1 or 13-2 minus A_{ograt} minus A_{ogort} .

EQUATION 13-2
Proposed UA_p

$$UA_p = U_m A_m + U_{or} A_{or} + U_{og} A_{og} + U_w A_w + U_d A_d + U_{vg} A_{vg} + U_f A_f + F_s P_s + U_{bgw} A_{bgw}$$

Where:

UA _p	=	The combined proposed specific heat transfer of the gross exterior wall, floor and roof/ceiling assembly area.
U _m	=	The thermal transmittance of the roof over attic area.
A _m	=	Opaque roof over attic area.
U _{or}	=	The thermal transmittance of the other roof area.
A _{or}	=	Opaque other roof area.
U _{og}	=	The thermal transmittance for the overhead glazing
A _{og}	=	Overhead glazing area.
U _w	=	The thermal transmittance of the opaque wall area.
A _w	=	Opaque above grade wall area (not including opaque doors).
U _{vg}	=	The thermal transmittance of the vertical glazing area.
A _{vg}	=	Vertical glazing area.
U _d	=	The thermal transmittance value of the opaque door area.
A _d	=	Opaque door area.
U _f	=	The thermal transmittance of the floor over unconditioned space area.
A _f	=	Floor area over unconditioned space.
F _s	=	Slab-on-grade or radiant floor component F-factor.
P _s	=	Lineal feet of slab-on-grade or radiant floor perimeter.
U _{bgw}	=	The thermal transmittance value of the below grade wall area.
A _{bgw}	=	Below grade wall area as defined in Tables 13-1 or 13-2.

NOTE: Where more than one type of wall, window, roof/ceiling, door and skylight is used, the U and A terms for those items shall be expanded into sub-elements as:

$$U_{w1} A_{w1} + U_{w2} A_{w2} + U_{w3} A_{w3} + \dots \text{etc.}$$

EQUATION 13-3

Target SHGCA_t

$$SHGCA_t = SHGC_t (A_{ograt} + A_{ogort} + A_{vgt})$$

Where:

SHGCA _t	=	The target combined specific heat gain of the target glazing area.
SHGC _t	=	The solar heat gain coefficient for glazing found in Table 13-1 or 13-2 which corresponds to the proposed total glazing area as a percent of gross exterior wall area, and
A _{ograt} , A _{ogort} , and A _{vgt}		are defined under Equation 13-1.

EQUATION 13-4

Proposed SHGCA_p

$$SHGCA_p = SHGC_{og} A_{og} + SHGC_{vg} A_{vg}$$

Where:

SHGCA _t	=	The combined proposed specific heat gain of the proposed glazing area.
SHGC _{og}	=	The solar heat gain coefficient of the overhead glazing.
A _{og}	=	The overhead glazing area.
SHGC _{vg}	=	The solar heat gain coefficient of the vertical glazing.
A _{vg}	=	The vertical glazing area.

**TABLE 13-1
BUILDING ENVELOPE REQUIREMENTS FOR CLIMATE ZONE 1
MINIMUM INSULATION R-VALUES OR
MAXIMUM COMPONENT U-FACTORS FOR ZONE 1**

Building Components

Space Heat Type	Components					
	Roofs Over Attic	All Other Roofs	Opaque Walls ^{1,2}	Opaque Doors	Floor Over Uncond Space	Slab On Grade ⁵
1. Electric resistance heat**	R-38 or U = 0.031	R-30 or U = 0.034	R-19 or U = 0.062	U = 0.60	R-30 or U = 0.029	R-10 or F = 0.54
2. All others including Heat pumps and VAV	R-30 or U = 0.036	R-21 or U = 0.050	R-11 or U = 0.14	U = 0.60	R-19 or U = 0.056	R-10 or F = 0.54

** Compliance with nominal prescriptive R-values requires wood framing.

**MAXIMUM GLAZING AREAS AND U-FACTORS AND
MAXIMUM GLAZING SOLAR HEAT GAIN COEFFICIENTS
FOR ZONE 1**

Glazing

Maximum Glazing Area as % of Wall	0% to 15%			>15% to 20%			>20% to 30%			>30% to 40%		
	Maximum U-Factor		Max. SHGC ⁴	Maximum U-Factor		Max. SHGC ⁴	Maximum U-Factor		Max. SHGC ⁴	Maximum U-Factor		Max. SHGC ⁴
	VG	OG		VG	OG		VG	OG		VG	OG	
1. Electric resistance heat	0.40	0.80	1.0	0.40	0.80	1.0	PRESCRIPTIVE PATH NOT ALLOWED					
2. All others including Heat pumps and VAV	0.90	1.45	1.0	0.75	1.40	1.0	0.60	1.30	0.65	0.50	1.25	0.45

Footnotes

1. Below Grade Walls:

When complying by the prescriptive approach, Section 1322:

- a) walls insulated on the interior shall use opaque wall values,
- b) walls insulated on the exterior shall use a minimum of R-10 insulation,
- c) those portions of below grade walls and footings that are more than 10 feet below grade, and not included in the gross exterior wall area, may be left uninsulated.

When complying by the component performance approach, Section 1331:

- a) walls insulated on the interior shall use the opaque wall values when determining U_{bgwt} ,
- b) walls insulated on the exterior shall use a target U-factor of $U = 0.070$ for U_{bgwt} ,
- c) those portions of below grade walls and footings that are more than 10 feet below grade, and not included in the gross exterior wall area, need not be included when determining A_{bgwt} and A_{bgw} .

- 2. **Concrete Masonry Walls:** If the area weighted heat capacity of the total opaque above grade wall is a minimum of 9.0 Btu/ft² • °F, then the U-factor may be increased to 0.19 for interior insulation and 0.25 for integral and exterior insulation for insulation position as defined in Chapter 2. Individual walls with heat capacities less than 9.0 Btu/ft² • °F and below grade walls shall meet opaque wall requirements listed above. Glazing shall comply with the following:

Maximum Glazing Area as % of Wall	0 to 10 %			>10 to 15 %			>15% to 20 %			>20% to 25 %		
	Maximum U-Factor		Max. SHGC ⁴	Maximum U-Factor		Max. SHGC ⁴	Maximum U-Factor		Max. SHGC ⁴	Maximum U-Factor		Max. SHGC ⁴
	VG	OG		VG	OG		VG	OG		VG	OG	
1. Electric resistance heat	0.40	0.80	1.0	0.40	0.80	1.0	0.40	0.80	1.0	NOT ALLOWED		
2. All others including Heat pumps and VAV	0.90	1.45	1.0	0.75	1.40	1.0	0.65	1.30	0.80	0.60	1.30	0.65

3. Reserved.

4. **SHGC (Solar Heat Gain Coefficient per Section 1312.2):** May substitute Maximum Shading Coefficient (SC) for SHGC (See Chapter 2 for definition of Shading Coefficient).

5. **Radiant Floors:** Where insulation is required under the entire slab, radiant floors shall use a minimum of R-10 insulation or F = 0.55 maximum. Where insulation is not required under the entire slab, radiant floors shall use R-10 perimeter insulation according to Section 1311.6 or F = 0.78 maximum.

**TABLE 13-2
BUILDING ENVELOPE REQUIREMENTS
FOR CLIMATE ZONE 2
MINIMUM INSULATION R-VALUES OR
MAXIMUM COMPONENT U-FACTORS FOR ZONE 2**

Building Components

Space Heat Type	Components					
	Roofs Over Attic	All Other Roofs	Opaque Walls ^{1,2}	Opaque Doors	Floor Over Uncond Space	Slab On Grade
1. Electric resistance heat**	R-38 or U = 0.031	R-30 or U = 0.034	R-24 or U = 0.044	U = 0.60	R-30 or U = 0.029	R-10 or F = 0.54
2. All others including Heat pumps and VAV	R-38 or U = 0.031	R-25 or U = 0.040	R-19 or U = 0.11	U = 0.60	R-21 or U = 0.047	R-10 or F = 0.54

** Compliance with nominal prescriptive R-values requires wood framing.

**MAXIMUM GLAZING AREAS AND U-FACTORS AND
MAXIMUM GLAZING SOLAR HEAT GAIN COEFFICIENTS
FOR ZONE 2**

Glazing

Maximum Glazing Area as % of Wall	0% to 15%		>15% to 20%		>20% to 25%		>25% to 30%					
	Maximum U-Factor		Max. SHGC ⁴	Maximum U-Factor		Max. SHGC ⁴	Maximum U-Factor		Max. SHGC ⁴			
	VG	OG		VG	OG		VG	OG				
1. Electric resistance heat	0.40	0.80	1.0	0.40	0.80	1.0	PRESCRIPTIVE PATH NOT ALLOWED					
2. All others including Heat pumps and VAV	0.90	1.45	1.0	0.75	1.40	1.0	0.60	1.30	0.60	0.50	1.25	0.50

Footnotes

1. Below Grade Walls:

When complying by the prescriptive approach, Section 1322:

- a) walls insulated on the interior shall use opaque wall values,
- b) walls insulated on the exterior shall use a minimum of R-12 insulation,
- c) those portions of below grade walls and footings that are more than 10 feet below grade, and not included in the gross exterior wall area, may be left uninsulated.

When complying by the component performance approach, Section 1331:

- a) walls insulated on the interior shall use the opaque wall values when determining U_{bgwt} ,
- b) walls insulated on the exterior shall use a target U-factor of $U = 0.061$ for U_{bgwt} ,
- c) those portions of below grade walls and footings that are more than 10 feet below grade, and not included in the gross exterior wall area, need not be included when determining A_{bgwt} and A_{bgw} .

2. Concrete Masonry Walls: If the area weighted heat capacity of the total opaque above grade wall is a minimum of 9.0 Btu/ft² • °F, then the U-factor may be increased to 0.19 for interior insulation and 0.25 for integral and exterior insulation for insulation position as defined in Chapter 2. Individual walls with heat capacities less than 9.0 Btu/ft² • °F and below grade walls shall meet opaque wall requirements listed above. Glazing shall comply with the following:

Maximum Glazing Area as % of Wall	0 to 5 %			>5 to 7 %			>7% to 10 %			>10% to 15 %		
	Maximum U-Factor		Max. SHGC ⁴	Maximum U-Factor		Max. SHGC ⁴	Maximum U-Factor		Max. SHGC ⁴	Maximum U-Factor		Max. SHGC ⁴
	VG	OG		VG	OG		VG	OG		VG	OG	
1. Electric resistance heat	0.40	0.80	1.0	0.40	0.80	1.0	0.40	0.80	1.0	NOT ALLOWED		
2. All others including Heat pumps and VAV	0.90	1.45	1.0	0.60	1.30	0.70	0.50	1.25	0.50	0.40	0.80	0.40

3. Reserved.

4. SHGC (Solar Heat Gain Coefficient per Section 1312.2): May substitute Maximum Shading Coefficient (SC) for SHGC (See Chapter 2 for definition of Shading Coefficient).

5. Radiant Floors: Where insulation is required under the entire slab, radiant floors shall use a minimum of R-10 insulation or F = 0.55 maximum. Where insulation is not required under the entire slab, radiant floors shall use R-10 perimeter insulation according to Section 1311.6 or F = 0.78 maximum.

[Statutory Authority: RCW 19.27A.025, 19.27A.045, 01-03-010, § 51-11-1334, filed 1/5/01, effective 7/1/01; 98-03-003, § 51-11-1334, filed 1/8/98, effective 7/1/98. Statutory Authority: RCW 19.27A.025, 93-21-052, § 51-11-1334, filed 10/18/93, effective 4/1/94.]

Reviser's note: RCW 34.05.395 requires the use of underlining and deletion marks to indicate amendments to existing rules, and deems ineffectual changes not filed by the agency in this manner. The bracketed material in the above section does not appear to conform to the statutory requirement.

Reviser's note: The brackets and enclosed material in the text of the above section occurred in the copy filed by the agency.

CHAPTER 14
BUILDING MECHANICAL SYSTEMS

WAC 51-11-1401 Scope. This section covers the determination of requirements, system and component performance, control requirements and duct construction.

[Statutory Authority: RCW 19.27A.025, 19.27A.045, 02-01-112, § 51-11-1401, filed 12/18/01, effective 7/1/02. Statutory Authority: RCW 19.27A.025, 93-21-052, § 51-11-1401, filed 10/18/93, effective 4/1/94.]

WAC 51-11-1402 Mechanical ventilation. The minimum requirements for ventilation shall comply with the

Washington State Ventilation and Indoor Air Quality Code (chapter 51-13 WAC).

[Statutory Authority: RCW 19.27A.025, 93-21-052, § 51-11-1402, filed 10/18/93, effective 4/1/94.]

WAC 51-11-1410 General requirements. The building mechanical system shall comply with Sections 1411 through 1416, Sections 1440 through 1443 and Sections 1450 through 1454, and with one of the following paths:

- a. Simple Systems (Packaged Unitary Equipment) Sections 1420 through 1424.
- b. Complex Systems Sections 1430 through 1439.
- c. Systems Analysis. See Section 1141.4.

FIGURE 14A
Mechanical Systems Compliance Paths

Section Number	Subject	Simple Systems Path	Complex Systems Path	Systems Analysis Option
1410	General Requirements	X	X	X
1411	HVAC Equipment Performance Requirements	X	X	X
1412	Controls	X	X	X
1413	Air Economizers	X	X	X
1414	Ducting Systems	X	X	X
1415	Piping Systems	X	X	X
1416	Completion Requirements	X	X	X
1420	Simple Systems (Packaged Unitary Equipment)	X		
1421	System Type	X		
1422	Controls	X		
1423	Economizers	X		
1424	Separate Air Distribution Systems	X		
1430	Complex Systems		X	
1431	System Type		X	
1432	Controls		X	
1433	Economizers		X	
1434	Separate Air Distribution Systems		X	
1435	Simultaneous Heating and Cooling		X	
1436	Heat Recovery		X	
1437	Electric Motor Efficiency		X	
1438	Variable Flow Systems		X	
1439	Exhaust Hoods		X	
RS-29	Systems Analysis			X
1440	Service Water Heating	X	X	X
1441	Water Heater Installation	X	X	X
1442	Shut Off Controls	X	X	X
1443	Pipe Insulation	X	X	X
1450	Heated Pools	X	X	X
1451	General	X	X	X
1452	Pool Water Heaters	X	X	X
1453	Controls	X	X	X
1454	Pool Covers	X	X	X

[Statutory Authority: RCW 19.27A.025, 19.27A.045, 01-03-010, § 51-11-1410, filed 1/5/01, effective 7/1/01. Statutory Authority: RCW 19.27A.025, 93-21-052, § 51-11-1410, filed 10/18/93, effective 4/1/94.]

WAC 51-11-1411 HVAC equipment performance requirements.

1411.1 General: Equipment shall have a minimum performance at the specified rating conditions not less than the values shown in Tables 14-1A through 14-1G. If a nationally recognized certification program exists for a product covered in Tables 14-1A through 14-1G, and it includes provisions for verification and challenge of equipment efficiency ratings, then the product shall be listed in the certification program.

Gas-fired and oil-fired forced air furnaces with input ratings $\geq 225,000$ Btu/h (65 kW) shall also have an intermittent ignition or interrupted device (IID), and have either mechanical draft (including power venting) or a flue damper. A vent damper is an acceptable alternative to a flue damper for furnaces where combustion air is drawn from the conditioned space. All furnaces with input ratings $\geq 225,000$ Btu/h (65 kW), including electric furnaces, that are not located within the conditioned space shall have jacket losses not exceeding 0.75% of the input rating.

1411.2 Rating Conditions: Cooling equipment shall be rated at ARI test conditions and procedures when available. Where no applicable procedures exist, data shall be furnished by the equipment manufacturer.

1411.3 Combination Space and Service Water Heating: For combination space and service water heaters with a principal function of providing space heat, the Combined Annual Efficiency (CAE) may be calculated by using ASHRAE Standard 124-1991. Storage water heaters used in combination space heat and water heat applications shall have either an Energy Factor (EF) or a Combined Annual Efficiency (CAE) of not less than the following:

	Energy Factor (EF)	Combined Annual Efficiency (CAE)
< 50 gallon storage	0.58	0.71
50 to 70 gallon storage	0.57	0.71
> 70 gallon storage	0.55	0.70

1411.4 Packaged Electric Heating and Cooling Equipment: Packaged electric equipment providing both heating and cooling with a total cooling capacity greater than 20,000 Btu/h shall be a heat pump.

EXCEPTION: Unstaffed equipment shelters or cabinets used solely for personal wireless service facilities.

[Statutory Authority: RCW 19.27A.025, 19.27A.045, 02-01-112, § 51-11-1411, filed 12/18/01, effective 7/1/02; 01-03-010, § 51-11-1411, filed 1/5/01, effective 7/1/01; 98-03-003, § 51-11-1411, filed 1/8/98, effective 7/1/98. Statutory Authority: RCW 19.27A.025, 93-21-052, § 51-11-1411, filed 10/18/93, effective 4/1/94.]

WAC 51-11-1412 Controls.

1412.1 Temperature Controls: Each system shall be provided with at least one temperature control device. Each zone shall be controlled by individual thermostatic controls responding to temperature within the zone. At a minimum, each floor of a building shall be considered as a separate zone.

1412.2 Deadband Controls: When used to control both comfort heating and cooling, zone thermostatic controls shall be

(2003 Ed.)

capable of a deadband of at least 5 degrees F within which the supply of heating and cooling energy to the zone is shut off or reduced to a minimum.

EXCEPTIONS:

1. Special occupancy, special usage, or code requirements where deadband controls are not appropriate.
2. Buildings complying with Section 1141.4, if in the proposed building energy analysis, heating and cooling thermostat setpoints are set to the same temperature between 70 degrees F and 75 degrees F inclusive, and assumed to be constant throughout the year.
3. Thermostats that require manual changeover between heating and cooling modes.

1412.3 Humidity Controls: If a system is equipped with a means for adding moisture, a humidistat shall be provided.

1412.4 Setback and Shut-Off: HVAC systems shall be equipped with automatic controls capable of accomplishing a reduction of energy use through control setback or equipment shutdown during periods of nonuse or alternate use of the spaces served by the system. The automatic controls shall have a minimum seven-day clock and be capable of being set for seven different day types per week.

EXCEPTIONS:

1. Systems serving areas which require continuous operation at the same temperature setpoint.
2. Equipment with full load demands of 2 Kw (6,826 Btu/h) or less may be controlled by readily accessible manual off-hour controls.

1412.4.1 Dampers: Outside air intakes, exhaust outlets and relief outlets serving conditioned spaces shall be equipped with motorized dampers which close automatically when the system is off or upon power failure.

EXCEPTIONS:

1. Systems serving areas which require continuous operation.
2. Combustion air intakes.
3. Gravity (nonmotorized) dampers are acceptable in buildings less than 3 stories in height.
4. Gravity (nonmotorized) dampers are acceptable in exhaust and relief outlets in the first story and levels below the first story of buildings three or more stories in height.

Dampers installed to comply with this section, including dampers integral to HVAC equipment, shall have a maximum leakage rate when tested in accordance with AMCA Standard 500 of:

(a) Motorized dampers: 10 cfm/ft² of damper area at 1.0 in w.g.

(b) Nonmotorized dampers: 20 cfm/ft² of damper area at 1.0 in w.g., except that for nonmotorized dampers smaller than 24 inches in either dimension: 40 cfm/ft² of damper area at 1.0 in w.g.

Drawings shall indicate compliance with this section.

1412.4.2 Optimum Start Controls: Heating and cooling systems with design supply air capacities exceeding 10,000 cfm shall have optimum start controls. Optimum start controls shall be designed to automatically adjust the start time of an HVAC system each day to bring the space to desired occupied temperature levels immediately before scheduled occupancy. The control algorithm shall, as a minimum, be a function of the difference between space temperature and occupied setpoint and the amount of time prior to scheduled occupancy.

1412.5 Heat Pump Controls: Unitary air cooled heat pumps shall include microprocessor controls that minimize supplemental heat usage during start-up, set-up, and defrost condi-

tions. These controls shall anticipate need for heat and use compression heating as the first stage of heat. Controls shall indicate when supplemental heating is being used through visual means (e.g., LED indicators).

1412.6 Combustion Heating Equipment Controls: Combustion heating equipment with a capacity over 225,000 Btu/h shall have modulating or staged combustion control.

EXCEPTIONS: Boilers.
Radiant heaters.

1412.7 Balancing: Each air supply outlet or air or water terminal device shall have a means for balancing, including but not limited to, dampers, temperature and pressure test connections and balancing valves.

[Statutory Authority: RCW 19.27A.025, 19.27A.045. 02-01-112, § 51-11-1412, filed 12/18/01, effective 7/1/02; 01-03-010, § 51-11-1412, filed 1/5/01, effective 7/1/01; 98-03-003, § 51-11-1412, filed 1/8/98, effective 7/1/98. Statutory Authority: RCW 19.27A.025. 93-21-052, § 51-11-1412, filed 10/18/93, effective 4/1/94.]

WAC 51-11-1413 Economizers.

1413.1 Operation: Air economizers shall be capable of automatically modulating outside and return air dampers to provide 100 percent of the design supply air as outside air to reduce or eliminate the need for mechanical cooling. Air economizers shall be used for RS-29 analysis base case for all systems without exceptions in Sections 1413, 1423, or 1433. Water economizers shall be capable of providing the total concurrent cooling load served by the connected terminal equipment lacking airside economizer, at outside air temperatures of 45°F dry-bulb/40°F wet-bulb and below. For this calculation, all factors including solar and internal load shall be the same as those used for peak load calculations, except for the outside temperatures.

EXCEPTION: Water economizers using air-cooled heat rejection equipment may use a 35°F dry-bulb outside air temperature for this calculation. This exception is limited to a maximum of 20 tons per building.

1413.2 **Documentation:** Water economizer plans submitted for approval shall include the following information:

1. Maximum outside air conditions for which economizer is sized to provide full cooling.
2. Design cooling load to be provided by economizer at this outside air condition.
3. Heat rejection and terminal equipment performance data including model number, flow rate, capacity, entering and leaving temperature in full economizer cooling mode.

1413.3 Integrated Operation: The HVAC system and its controls shall allow economizer operation when mechanical cooling is required simultaneously. Air and water economizers shall be capable of providing partial cooling even when additional mechanical cooling is required to meet the remainder of the cooling load.

EXCEPTIONS: 1. Individual, direct expansion units that have a rated capacity less than 65,000 Btu/h and use nonintegrated economizer controls that preclude simultaneous operation of the economizer and mechanical cooling.
2. Water-cooled water chillers.

1413.4 **Humidification:** If an air economizer is required on a cooling system for which humidification equipment is to be

provided to maintain minimum indoor humidity levels, then the humidifier shall be of the adiabatic type (direct evaporative media or fog atomization type) that cools return air while humidifying outside air while in economizer. If a water economizer or no economizer is provided, the isothermal type of humidifier may be used (steam injection, gas, electric resistance or infrared generator type that uses new energy to boil moisture to be added).

EXCEPTION: Health care facilities where WAC 246-320-525 allows only steam injection humidifiers in ductwork downstream of final filters.

[Statutory Authority: RCW 19.27A.025, 19.27A.045. 02-01-112, § 51-11-1413, filed 12/18/01, effective 7/1/02. Statutory Authority: RCW 19.27A.025. 93-21-052, § 51-11-1413, filed 10/18/93, effective 4/1/94.]

WAC 51-11-1414 Ducting systems.

1414.1 Sealing: Duct work which is designed to operate at pressures above 1/2 inch water column static pressure shall be sealed in accordance with Standard RS-18. Extent of sealing required is as follows:

1. Static pressure: 1/2 inch to 2 inches; seal transverse joints.
2. Static pressure: 2 inches to 3 inches; seal all transverse joints and longitudinal seams.
3. Static pressure: Above 3 inches; seal all transverse joints, longitudinal seams and duct wall penetrations.

Duct tape and other pressure sensitive tape shall not be used as the primary sealant where ducts are designed to operate at static pressures of 1 inch W.C. or greater.

1414.2 Insulation: Ducts and plenums that are constructed and function as part of the building envelope, by separating interior space from exterior space, shall meet all applicable requirements of Chapter 13. These requirements include insulation installation, moisture control, air leakage, and building envelope insulation levels. Unheated equipment rooms with combustion air louvers must be isolated from the conditioned space by insulating interior surfaces to a minimum of R-11 and any exterior envelope surfaces per Chapter 13. Outside air ducts serving individual supply air units with less than 2,800 cfm of total supply air capacity shall be insulated to a minimum of R-7 and are not considered building envelope. Other outside air duct runs are considered building envelope until they,

1. Connect to the heating or cooling equipment, or
2. Are isolated from the exterior with an automatic shut-off damper complying with Section 1412.4.1.

Once outside air ducts meet the above listed requirements, any runs within conditioned space shall comply with Table 14-5 requirements.

Other ducts and plenums shall be thermally insulated per Table 14-5.

EXCEPTIONS: 1. Within the HVAC equipment.
2. Exhaust air ducts not subject to condensation.
3. Exposed ductwork within a zone that serves that zone.

[Statutory Authority: RCW 19.27A.025, 19.27A.045. 01-03-010, § 51-11-1414, filed 1/5/01, effective 7/1/01; 98-03-003, § 51-11-1414, filed 1/8/98, effective 7/1/98. Statutory Authority: RCW 19.27A.025. 93-21-052, § 51-11-1414, filed 10/18/93, effective 4/1/94.]

WAC 51-11-1415 Piping systems.

1415.1 Insulation: Piping shall be thermally insulated in accordance with Table 14-6.

EXCEPTION: Piping installed within unitary HVAC equipment.

Cold water pipes outside the conditioned space shall be insulated in accordance with the Washington State Plumbing Code (chapter 51-46 WAC).

[Statutory Authority: RCW 19.27A.025, 19.27A.045. 01-03-010, § 51-11-1415, filed 1/5/01, effective 7/1/01. Statutory Authority: RCW 19.27A.025. 93-21-052, § 51-11-1415, filed 10/18/93, effective 4/1/94.]

WAC 51-11-1416 Completion requirements.

1416.1 Drawings: Construction documents shall require that within 90 days after the date of system acceptance, record drawings of the actual installation be provided to the building owner. Record drawings shall include as a minimum the location and performance data on each piece of equipment, general configuration of duct and pipe distribution system, including sizes, and the terminal air and water design flow rates.

1416.2 Manuals: Construction documents shall require an operating manual and maintenance manual be provided to the building owner. The manual shall be in accordance with industry accepted standards and shall include, at a minimum, the following:

1. Submittal data stating equipment size and selected options for each piece of equipment requiring maintenance.

2. Operation and maintenance manuals for each piece of equipment requiring maintenance, except equipment not furnished as part of the project. Required routine maintenance actions shall be clearly identified.

3. Names and addresses of at least one service agency.

4. HVAC controls system maintenance and calibration information, including wiring diagrams, schematics, and control sequence descriptions. Desired or field determined set points shall be permanently recorded on control drawings at control devices, or, for digital control systems, in programming comments.

5. A complete narrative of how each system is intended to operate including suggested set points.

1416.3 System Balancing

1416.3.1 General: Construction documents shall require that all HVAC systems be balanced in accordance with generally accepted engineering standards. Air and water flow rates shall be measured and adjusted to deliver final flow rates within 10% of design rates, except variable flow distribution systems need not be balanced upstream of the controlling device (for example, VAV box or control valve). Construction documents shall require a written balance report be provided to the owner.

1416.3.2 Air System Balancing: Air systems shall be balanced in a manner to first minimize throttling losses then, for fans with system power of greater than 1 hp, fan speed shall be adjusted to meet design flow conditions.

1416.3.3 Hydronic System Balancing: Hydronic systems shall be proportionately balanced in a manner to first minimize throttling losses, then the pump impeller shall be trimmed or pump speed shall be adjusted to meet design flow conditions. Each hydronic system shall have either the ability to measure pressure across the pump, or test ports at each side of each pump.

EXCEPTIONS:

1. Pumps with pump motors of 10 hp or less.
2. When throttling results in no greater than 5% of the nameplate horsepower draw above that required if the impeller were trimmed.

1416.4 Systems Commissioning

1416.4.1 Simple Systems: For simple systems, as defined in Section 1421, and for warehouses and semi-heated spaces, HVAC control systems shall be tested to ensure that control devices, components, equipment and systems are calibrated, adjusted and operate in accordance with approved plans and specifications. Sequences of operation shall be functionally tested to ensure they operate in accordance with approved plans and specifications. A complete report of test procedures and results shall be prepared and filed with the owner. Drawing notes shall require commissioning in accordance with this paragraph.

1416.4.2 Other Systems: All other HVAC control systems, and other automatically controlled systems for which energy consumption, performance, or mode of operation are regulated by this code, shall be tested to ensure that control devices, equipment and systems are calibrated, adjusted and operate in accordance with approved plans and specifications. Sequences of operation shall be functionally tested to ensure they operate in accordance with approved plans and specifications.

1416.4.2.1 Documentation: Drawing notes shall require commissioning in accordance with this section. Drawing notes may refer to specifications for further commissioning requirements. Plans and specifications shall require tests mandated by this section be performed and the results recorded. Plans and specifications shall require preparation of preliminary and final reports of test procedures and results as described in Section 1416.4.2.2. Plans and specifications shall identify the following for each test:

1. Equipment and systems to be tested, including the extent of sampling tests,

2. Functions to be tested (for example calibration, economizer control, etc.),

3. Conditions under which the test shall be performed (for example winter design conditions, full outside air, etc.),

4. Measurable criteria for acceptable performance.

1416.4.2.2 Commissioning Reports

1416.4.2.2.1 Preliminary Commissioning Report: A preliminary commissioning report of test procedures and results shall be prepared. The preliminary report shall identify:

1. Deficiencies found during testing required by this section which have not been corrected at the time of report preparation and the anticipated date of correction.

2. Deferred tests which cannot be performed at the time of report preparation due to climatic conditions.

3. Climatic conditions required for performance of the deferred tests, and the anticipated date of each deferred test.

1416.4.2.2.2 Final Commissioning Report: A complete report of test procedures and results shall be prepared and filed with the owner.

1416.4.2.3 Acceptance: Buildings or portions thereof, required by this code to comply with this section, shall not be issued a final certificate of occupancy until such time that the building official determines that the preliminary commissioning report required by this section has been completed.

[Statutory Authority: RCW 19.27A.025, 19.27A.045. 01-03-010, § 51-11-1416, filed 1/5/01, effective 7/1/01.]

WAC 51-11-1420 Simple systems (packaged unitary equipment).

[Statutory Authority: RCW 19.27A.025. 93-21-052, § 51-11-1420, filed 10/18/93, effective 4/1/94.]

WAC 51-11-1421 System type. To qualify as a simple system, systems shall be one of the following:

- a. Air cooled, constant volume packaged equipment, which provide heating, cooling or both, and require only external connection to duct work and energy services.
- b. Air cooled, constant volume split systems, which provide heating, cooling or both, with cooling capacity of 84,000 Btu/h or less.
- c. Heating only systems which have a capacity of less than 5,000 cfm or which have a minimum outside air supply of less than 70 percent of the total air circulation.

All other systems shall comply with Sections 1430 through 1438.

[Statutory Authority: RCW 19.27A.025 and 19.27A.045. 98-03-003, § 51-11-1421, filed 1/8/98, effective 7/1/98. Statutory Authority: RCW 19.27A.025. 93-21-052, § 51-11-1421, filed 10/18/93, effective 4/1/94.]

WAC 51-11-1422 Controls. In addition to the control requirements in Section 1412, where separate heating and cooling equipment serve the same temperature zone, thermostats shall be interlocked to prevent simultaneous heating and cooling. Systems which provide heating and cooling simultaneously to a zone are prohibited.

[Statutory Authority: RCW 19.27A.025 and 19.27A.045. 98-03-003, § 51-11-1422, filed 1/8/98, effective 7/1/98. Statutory Authority: RCW 19.27A.025. 93-21-052, § 51-11-1422, filed 10/18/93, effective 4/1/94.]

WAC 51-11-1423 Economizers. Economizers meeting the requirements of Section 1413 shall be installed on single package unitary fan-cooling units having a supply capacity of greater than 1,900 cfm or a total cooling capacity greater than 54,000 Btu/h including those serving computer server rooms, electronic equipment, radio equipment, telephone switchgear.

The total capacity of all units without economizers shall not exceed 240,000 Btu/h per building, or 10% of its aggregate

cooling (economizer) capacity, whichever is greater. That portion of the equipment serving Group R Occupancy is not included in determining the total capacity of all units without economizers in a building.

[Statutory Authority: RCW 19.27A.025, 19.27A.045. 02-01-112, § 51-11-1423, filed 12/18/01, effective 7/1/02; 01-03-010, § 51-11-1423, filed 1/5/01, effective 7/1/01; 98-03-003, § 51-11-1423, filed 1/8/98, effective 7/1/98. Statutory Authority: RCW 19.27A.025. 93-21-052, § 51-11-1423, filed 10/18/93, effective 4/1/94.]

WAC 51-11-1424 Separate air distribution systems. Zones with special process temperature requirements and/or humidity requirements shall be served by separate air distribution systems from those serving zones requiring only comfort conditions.

[Statutory Authority: RCW 19.27A.025. 93-21-052, § 51-11-1424, filed 10/18/93, effective 4/1/94.]

WAC 51-11-1430 Complex systems.

[Statutory Authority: RCW 19.27A.025. 93-21-052, § 51-11-1430, filed 10/18/93, effective 4/1/94.]

WAC 51-11-1431 System type. All systems not qualifying for Sections 1420 through 1424 (Simple Systems), including field fabricated and constructed of system components, shall comply with Sections 1430 through 1438. Simple systems may also comply with Sections 1430 through 1438.

1431.1 Field-Assembled Equipment and Components: Field-assembled equipment and components from more than one manufacturer shall show compliance with this section and Section 1411 through calculations of total on-site energy input and output. The combined component efficiencies as measured per Section 1411.2, shall be in compliance with the requirements of Section 1411.1.

Total on-site energy input to the equipment shall be determined by combining the energy inputs to all components, elements, and accessories such as compressor(s), internal circulating pump(s), purge devices, viscosity control heaters, and controls.

[Statutory Authority: RCW 19.27A.025. 93-21-052, § 51-11-1431, filed 10/18/93, effective 4/1/94.]

WAC 51-11-1432 Controls.

1432.1 Setback and Shut-off: Systems that serve zones with different uses, as defined in Table 15-1

1. Shall be served by separate systems, or
2. Shall include isolation devices and controls to shut off or set back the supply of heating and cooling to each zone independently.

EXCEPTION: Isolation or separate systems are not required for zones expected to operate continuously or expected to be inoperative only when all other zones are inoperative.

1432.2 Systems Temperature Reset Controls

1432.2.1 Air Systems for Multiple Zones: Systems supplying heated or cooled air to multiple zones shall include controls which automatically reset supply air temperatures by representative building loads or by outside air temperature.

Temperature shall be reset by at least 25 percent of the design supply-air-to-room-air temperature difference.

EXCEPTION: Where specified humidity levels are required to satisfy process needs, such as computer rooms or museums.

1432.2.2 Hydronic Systems: Systems with a design capacity of 600,000 Btu/h or greater supplying heated water to comfort conditioning systems shall include controls which automatically reset supply water temperatures by representative building loads (including return water temperature) or by outside air temperature. Temperature shall be reset by at least 25 percent of the design supply-to-return water temperature differences.

[Statutory Authority: RCW 19.27A.025, 93-21-052, § 51-11-1432, filed 10/18/93, effective 4/1/94.]

WAC 51-11-1433 Economizers. Air economizers meeting the requirements of Section 1413 shall be provided on all new systems including those serving computer server rooms, electronic equipment, radio equipment, telephone switchgear.

EXCEPTIONS:

1. Single package unitary fan-cooling units installed outdoors or in a mechanical room adjacent to outdoors with a total cooling capacity less than 20,000 Btu/h. Other single package unitary fan-cooling units with a total cooling capacity less than 54,000 Btu/h. The total capacity of all such systems without economizers shall not exceed 240,000 Btu/h per building, or 10% of its air economizer capacity, whichever is greater. That portion of the equipment serving Group R Occupancy is not included in determining the total capacity of all units without economizers in a building.
2. Water-cooled refrigeration equipment provided with a water economizer meeting the requirements of Section 1413. Water economizer capacity per building shall not exceed 500 tons. This exception shall not be used for RS-29 analysis.
3. Systems for which at least 75% of the annual energy used for mechanical cooling is provided from site-recovery or site-solar energy source.
4. Systems where special outside air filtration and treatment, for the reduction and treatment of unusual outdoor contaminants, makes an air economizer infeasible.
5. Systems that affect other systems (such as dehumidification and supermarket refrigeration systems) so as to increase the overall building energy consumption. New humidification equipment shall comply with Section 1413.4.

[Statutory Authority: RCW 19.27A.025, 19.27A.045, 02-01-112, § 51-11-1433, filed 12/18/01, effective 7/1/02; 01-03-010, § 51-11-1433, filed 1/5/01, effective 7/1/01; 98-03-003, § 51-11-1433, filed 1/8/98, effective 7/1/98. Statutory Authority: RCW 19.27A.025, 93-21-052, § 51-11-1433, filed 10/18/93, effective 4/1/94.]

WAC 51-11-1434 Separate air distribution systems. Zones with special process temperature requirements and/or humidity requirements shall be served by separate air distribution systems from those serving zones requiring only comfort conditions; or shall include supplementary control provisions so that the primary systems may be specifically controlled for comfort purposes only.

EXCEPTION: Zones requiring only comfort heating or comfort cooling that are served by a system primarily used for process temperature and humidity control provided that:

1. The total supply air to those comfort zones is no more than 25 percent of the total system supply air, or
2. The total conditioned floor area of the zones is less than 1,000 ft².

[Statutory Authority: RCW 19.27A.025, 93-21-052, § 51-11-1434, filed 10/18/93, effective 4/1/94.]

WAC 51-11-1435 Simultaneous heating and cooling. Systems which provide heating and cooling simultaneously to a zone are prohibited. Zone thermostatic and humidistatic controls shall be capable of operating in sequence the supply of heating and cooling energy to the zone. Such controls shall prevent:

- a. Reheating for temperature control.
- b. Recooling for temperature control.
- c. Mixing or simultaneous supply of air that has been previously mechanically heated and air that has been previously cooled, either by economizer systems or by mechanical refrigeration.
- d. Other simultaneous operation of heating and cooling systems to the same zone.
- e. Reheating for humidity control.

EXCEPTIONS:

1. Zones for which the volume of air that is reheated, recooled, or mixed is no greater than the larger of the following:
 - i. The volume of air required to meet the ventilation requirements of the Washington State Ventilation and Indoor Air Quality Code for the zone.
 - ii. 0.4 cfm/ft² of the zone conditioned floor area, provided that the temperature of the primary system air is, by design or through reset controls, 0-12°F below the design space heating temperature when outside air temperatures are below 60°F for reheat systems and the cold deck of mixing systems and 0-12°F above design space temperature when outside air temperatures are above 60°F for recooling systems and the hot deck of mixing systems. For multiple zone systems, each zone need not comply with this exception provided the average of all zones served by the system that have both heating and cooling ability comply.
 - iii. 300 cfm. This exception is for zones whose peak flow rate totals no more than 10% of the total fan system flow rate.
 - iv. Any higher rate that can be demonstrated, to the satisfaction of the building official, to reduce overall system annual energy usage by offsetting reheat/recool energy losses through a reduction in outdoor air intake in accordance with the multiple space requirements defined in ASHRAE Standard 62.
2. Zones where special pressurization relationships, cross-contamination requirements, or code-required minimum circulation rates are such that variable air volume systems are impractical.
3. Zones where at least 75% of the energy for reheating or for providing warm air in mixing systems is provided from a site-recovered (including condenser heat) or site solar energy source.
4. Zones where specific humidity levels are required to satisfy process needs, such as computer rooms, museums, surgical suites, and buildings with refrigerating systems, such as supermarkets, refrigerated warehouses, and ice arenas.

[Statutory Authority: RCW 19.27A.025, 19.27A.045, 01-03-010, § 51-11-1435, filed 1/5/01, effective 7/1/01. Statutory Authority: RCW 19.27A.025, 93-21-052, § 51-11-1435, filed 10/18/93, effective 4/1/94.]

WAC 51-11-1436 Heat recovery. Fan systems which have both a capacity of 5,000 cfm or greater and which have a minimum outside air supply of 70 percent or greater of the total air circulation shall have a heat recovery system with at least 50 percent recovery effectiveness. Fifty percent heat recovery effectiveness shall mean an increase in the outside air supply temperature at design heating conditions of one half the difference between the outdoor design air temperature and 65 degrees F. Provision shall be made to bypass or control the heat recovery system to permit air economizer

operation as required by Section 1433. Heat recovery energy may be provided from any site-recovered or site-solar source.

- EXCEPTIONS:
1. Laboratory systems equipped with both variable air volume supply and variable air volume or two-speed exhaust fume hoods.
 2. Systems serving spaces heated to less than 60 degrees F.
 3. Systems which can be shown to use as much energy with the addition of heat recovery equipment as without it.
 4. Systems exhausting toxic, flammable, paint exhaust or corrosive fumes making the installation of heat recovery equipment impractical.
 5. Type I commercial kitchen hoods.

[Statutory Authority: RCW 19.27A.025. 93-21-052, § 51-11-1436, filed 10/18/93, effective 4/1/94.]

WAC 51-11-1437 Electric motor efficiency. Design A & B squirrel-cage, T-frame induction permanently wired polyphase motors of 1 hp or more having synchronous speeds of 3,600, 1,800 and 1,200 rpm shall have a nominal full-load motor efficiency no less than the corresponding values for energy efficient motors provided in Table 14-4.

- EXCEPTIONS:
1. Motors used in systems designed to use more than one speed of a multi-speed motor.
 2. Motors used as a component of the equipment meeting the minimum equipment efficiency requirements of Section 1411 and Tables 14-1A through 14-1G provided that the motor input is included when determining the equipment efficiency.
 3. Motors that are an integral part of specialized process equipment.
 4. Where the motor is integral to a listed piece of equipment for which no complying motor has been approved.

[Statutory Authority: RCW 19.27A.025, 19.27A.045. 02-01-112, § 51-11-1437, filed 12/18/01, effective 7/1/02. Statutory Authority: RCW 19.27A.025. 93-21-052, § 51-11-1437, filed 10/18/93, effective 4/1/94.]

WAC 51-11-1438 Variable flow systems. For fans and pumps greater than 10 horsepower, where the application involves variable flow, there shall be variable speed drives or variable flow devices installed. Acceptable variable flow devices include variable inlet vanes, variable blade pitch, and variable fan geometry. Throttling valves (dampers), scroll dampers or bypass circuits shall not be allowed.

[Statutory Authority: RCW 19.27A.025, 19.27A.045. 01-03-010, § 51-11-1438, filed 1/5/01, effective 7/1/01. Statutory Authority: RCW 19.27A.025. 93-21-052, § 51-11-1438, filed 10/18/93, effective 4/1/94.]

WAC 51-11-1439 Exhaust hoods.

1439.1 Kitchen Hoods. Individual kitchen exhaust hoods larger than 5000 cfm shall be provided with make-up air sized so that at least 50% of exhaust air volume be (a) unheated or heated to no more than 60°F and (b) uncooled or cooled without the use of mechanical cooling.

- EXCEPTIONS:
1. Where hoods are used to exhaust ventilation air which would otherwise exfiltrate or be exhausted by other fan systems.
 2. Certified grease extractor hoods that require a face velocity no greater than 60 fpm.

1439.2 Fume Hoods. Each fume hood in buildings with fume hood systems having a total exhaust rate greater than 15,000 cfm shall include at least one of the following features:

(a) Variable air volume hood exhaust and room supply systems capable of reducing exhaust and make-up air volume to 50% or less of design values.

(b) Direct make-up (auxiliary) air supply equal to at least 75% of the exhaust rate, heated no warmer than 2°F below room set point, cooled to no cooler than 3°F above room set point, no humidification added, and no simultaneous heating and cooling used for dehumidification control.

(c) Heat recovery systems to precondition make-up air in accordance with Section 1436, without using any exception.

(d) Constant volume fume hood designed and installed to operate at less than 50 fpm face velocity.

[Statutory Authority: RCW 19.27A.025, 19.27A.045. 01-03-010, § 51-11-1439, filed 1/5/01, effective 7/1/01.]

WAC 51-11-1440 Service water heating.

[Statutory Authority: RCW 19.27A.025. 93-21-052, § 51-11-1440, filed 10/18/93, effective 4/1/94.]

WAC 51-11-1441 Water heater installation. Electric water heaters in unconditioned spaces or on concrete floors shall be placed on an incompressible, insulated surface with a minimum thermal resistance of R-10.

[Statutory Authority: RCW 19.27A.025. 93-21-052, § 51-11-1441, filed 10/18/93, effective 4/1/94.]

WAC 51-11-1442 Shut-off controls. Systems designed to maintain usage temperatures in hot water pipes, such as circulating hot water systems or heat traced pipes shall be equipped with automatic time switches or other controls to turn off the system during periods of nonuse.

[Statutory Authority: RCW 19.27A.025. 93-21-052, § 51-11-1442, filed 10/18/93, effective 4/1/94.]

WAC 51-11-1443 Pipe insulation. Piping shall be thermally insulated in accordance with Section 1415.1.

[Statutory Authority: RCW 19.27A.025, 19.27A.045. 01-03-010, § 51-11-1443, filed 1/5/01, effective 7/1/01.]

WAC 51-11-1450 Heated pools.

[Statutory Authority: RCW 19.27A.025. 93-21-052, § 51-11-1450, filed 10/18/93, effective 4/1/94.]

WAC 51-11-1451 General. The requirements in this section apply to "general and limited use pools" as defined in the Washington Water Recreation Facilities Regulations (chapter 246-260 WAC).

[Statutory Authority: RCW 19.27A.025. 93-21-052, § 51-11-1451, filed 10/18/93, effective 4/1/94.]

WAC 51-11-1452 Pool water heaters. Heat pump pool heaters shall have a minimum COP of 4.0 determined in accordance with ASHRAE Standard 146, Method of Testing for Rating Pool Heaters. Other pool heating equipment shall comply with the applicable efficiencies in Tables 14-1A through 14-1G.

[Statutory Authority: RCW 19.27A.025, 19.27A.045. 02-01-112, § 51-11-1452, filed 12/18/01, effective 7/1/02; 98-03-003, § 51-11-1452, filed

1/8/98, effective 7/1/98. Statutory Authority: RCW 19.27A.025. 93-21-052, § 51-11-1452, filed 10/18/93, effective 4/1/94.]

[Statutory Authority: RCW 19.27A.025. 93-21-052, § 51-11-1453, filed 10/18/93, effective 4/1/94.]

WAC 51-11-1453 Controls. All pool heaters shall be equipped with readily accessible ON/OFF switch to allow shutting off the operation of the heater without adjusting the thermostat setting. Controls shall be provided to allow the water temperature to be regulated from the maximum design temperature down to 65 degrees F.

WAC 51-11-1454 Pool covers. Heated pools shall be equipped with a vapor retardant pool cover on or at the water surface. Pools heated to more than 90 degrees F shall have a pool cover with a minimum insulation value of R-12.

Table 14-1A
Unitary Air Conditioners and Condensing Units, Electrically Operated, Minimum Efficiency Requirements

Equipment Type	Size Category	Sub-Category or Rating Condition	Minimum Efficiency ^b	Test Procedure ^a
Air Conditioners, Air Cooled	< 65,000 Btu/h ^d	Split System	10.0 SEER	ARI 210/240
		Single Package	9.7 SEER	
	≥ 65,000 Btu/h and < 135,000 Btu/h	Split System and Single Package	10.3 EER ^c	ARI 340/360
	≥ 135,000 Btu/h and < 240,000 Btu/h	Split System and Single Package	9.7 EER ^c	
	≥ 240,000 Btu/h and < 760,000 Btu/h	Split System and Single Package	9.5 EER ^c 9.7 IPLV ^c	
≥ 760,000 Btu/h	Split System and Single Package	9.2 EER ^c 9.4 IPLV ^c		
Air Conditioners, Water and Evaporatively Cooled	< 65,000 Btu/h	Split System and Single Package	12.1 EER	ARI 210/240
	≥ 65,000 Btu/h and < 135,000 Btu/h	Split System and Single Package	11.5 EER ^c	ARI 340/360
	≥ 135,000 Btu/h and ≤ 240,000 Btu/h	Split System and Single Package	11.0 EER ^c	
	> 240,000 Btu/h	Split System and Single Package	11.0 EER ^c 10.3 IPLV ^c	
Condensing Units, Air Cooled	≥ 135,000 Btu/h		10.1 EER 11.2 IPLV	ARI 365
Condensing Units, Water or Evaporatively Cooled	≥ 135,000 Btu/h		13.1 EER 13.1 IPLV	

^a Reserved.

^b IPLVs are only applicable to equipment with capacity modulation.

^c Deduct 0.2 from the required EERs and IPLVs for units with a heating section other than electric resistance heat.

^d Single-phase air-cooled air-conditioners < 65,000 Btu/h are regulated by NAECA. SEER values are those set by NAECA.

Table 14-1B
Unitary and Applied Heat Pumps, Electrically Operated, Minimum Efficiency Requirements

Equipment Type	Size Category	Sub-Category or Rating Condition	Minimum Efficiency ^b	Test Procedure ^a
Air Cooled, (Cooling Mode)	< 65,000 Btu/h ^d	Split System	10.0 SEER	ARI 210/240
		Single Package	9.7 SEER	
	≥ 65,000 Btu/h and < 135,000 Btu/h	Split System and Single Package	10.1 EER ^c	ARI 340/360
	≥ 135,000 Btu/h and < 240,000 Btu/h	Split System and Single Package	9.3 EER ^c	
≥ 240,000 Btu/h	Split System and Single Package	9.0 EER ^c 9.2 IPLV ^c		

Equipment Type	Size Category	Sub-Category or Rating Condition	Minimum Efficiency ^b	Test Procedure ^a
Water-Source (Cooling Mode)	< 17,000 Btu/h	86°F Entering Water	11.2 EER	ARI/ISO-13256-1
	≥ 17,000 Btu/h and < 65,000 Btu/h	86°F Entering Water	12.0 EER	ARI/ISO-13256-1
	≥ 65,000 Btu/h and < 135,000 Btu/h	86°F Entering Water	12.0 EER	ARI/ISO-13256-1
Groundwater-Source (Cooling Mode)	< 135,000 Btu/h	59°F Entering Water	16.2 EER	ARI/ISO-13256-1
Ground Source (Cooling Mode)	< 135,000 Btu/h	77°F Entering Water	13.4 EER	ARI/ISO-13256-1
Air Cooled (Heating Mode)	< 65,000 Btu/h ^d (Cooling Capacity)	Split System	6.8 HSPF	ARI 210/240
		Single Package	6.6 HSPF	
	≥ 65,000 Btu/h and < 135,000 Btu/h (Cooling Capacity)	47°F db/43°F wb Outdoor Air	3.2 COP	ARI 340/360
		17°F db/15°F wb Outdoor Air	2.2 COP	
≥ 135,000 Btu/h (Cooling Capacity)	47°F db/43°F wb Outdoor Air	3.1 COP	ARI 340/360	
17°F db/15°F wb Outdoor Air	2.0 COP			
Water-Source (Heating Mode)	< 135,000 Btu/h (Cooling Capacity)	68°F Entering Water	4.2 COP	ARI/ISO-13256-1
Groundwater-Source (Heating Mode)	< 135,000 Btu/h (Cooling Capacity)	50°F Entering Water	3.6 COP	ARI/ISO-13256-1
Ground Source (Heating Mode)	< 135,000 Btu/h (Cooling Capacity)	32°F Entering Water	3.1 COP	ARI/ISO-13256-1

^a Reserved.

^b IPLVs and part load rating conditions are only applicable to equipment with capacity modulation.

^c Deduct 0.2 from the required EERs and IPLVs for units with a heating section other than electric resistance heat.

^d Single-phase air-cooled heat pumps < 65,000 Btu/h are regulated by NAECA. SEER and HSPF values are those set by NAECA.

Table 14-1C
Water Chilling Packages, Minimum Efficiency Requirements

Equipment Type	Size Category	Sub-Category or Rating Condition	Minimum Efficiency ^b	Test Procedure ^a
Air Cooled, With Condenser, Electrically Operated	All Capacities		2.80 COP	ARI 550/590
			3.05 IPLV	
Air Cooled, Without Condenser, Electrically Operated	All Capacities		3.10 COP	ARI 550/590
			3.45 IPLV	
Water Cooled, Electrically Operated, Positive Displacement (Reciprocating)	All Capacities		4.20 COP 5.05 IPLV	ARI 550/590
Water Cooled, Electrically Operated, Positive Displacement (Rotary Screw and Scroll)	< 150 Tons		4.45 COP 5.20 IPLV	ARI 550/590
	≥ 150 Tons and < 300 Tons		4.90 COP 5.60 IPLV	
	≥ 300 Tons		5.50 COP 6.15 IPLV	
Water Cooled, Electrically Operated, Centrifugal	< 150 Tons		5.00 COP 5.25 IPLV	ARI 550/590

Equipment Type	Size Category	Sub-Category or Rating Condition	Minimum Efficiency ^b	Test Procedure ^a
Air Cooled, With Condenser, Electrically Operated	All Capacities		2.80 COP 3.05 IPLV	ARI 550/590
	≥ 150 Tons and < 300 Tons		5.55 COP 5.90 IPLV	
	≥ 300 Tons		6.10 COP 6.40 IPLV	
Air Cooled Absorption Single Effect	All Capacities		0.60 COP	ARI 560
Water Cooled Absorption Single Effect	All Capacities		0.70 COP	
Absorption Double Effect, Indirect-Fired	All Capacities		1.00 COP 1.05 IPLV	
Absorption Double Effect, Direct-Fired	All Capacities		1.00 COP 1.00 IPLV	

^a Reserved.
^b The chiller equipment requirements do not apply for chillers used in low temperature applications where the design leaving fluid temperature is less than or equal to 40°F.

Table 14-1D
Packaged Terminal Air Conditioners, Packaged Terminal Heat Pumps, Room Air Conditioners, and Room Air Conditioner Heat Pumps, Electrically Operated, Minimum Efficiency Requirements

Equipment Type	Size Category (Input)	Sub-Category or Rating Condition	Minimum Efficiency ^b	Test Procedure ^a
PTAC (Cooling Mode) New Construction	All Capacities	95°F db Outdoor Air	12.5 - (0.213 x Cap/1000) ^b EER	ARI 310/380
PTAC (Cooling Mode) Replacements ^c	All Capacities	95°F db Outdoor Air	10.9 - (0.213 x Cap/1000) ^b EER	
PTHP (Cooling Mode) New Construction	All Capacities	95°F db Outdoor Air	12.3 - (0.213 x Cap/1000) ^b EER	
PTHP (Cooling Mode) Replacements ^c	All Capacities	95°F db Outdoor Air	10.8 - (0.213 x Cap/1000) ^b EER	
PTHP (Heating Mode) New Construction	All Capacities		3.2 - (0.026 x Cap/1000) ^b COP	
PTHP (Heating Mode) Replacements ^c	All Capacities		2.9 - (0.026 x Cap/1000) ^b COP	
Room Air Conditioners, with Louvered Sides	< 6,000 Btu/h		9.7 EER	ANSI/AHAM RAC-1
	≥ 6,000 Btu/h and < 8,000 Btu/h		9.7 EER	
	≥ 8,000 Btu/h and < 14,000 Btu/h		9.8 EER	
	≥ 14,000 Btu/h and < 20,000 Btu/h		9.7 EER	
	≥ 20,000 Btu/h		8.5 EER	
Room Air Conditioners, without Louvered Sides	< 8,000 Btu/h		9.0 EER	
	≥ 8,000 Btu/h and < 20,000 Btu/h		8.5 EER	
	≥ 20,000 Btu/h		8.5 EER	
Room Air Conditioner Heat Pumps with Louvered Sides	< 20,000 Btu/h		9.0 EER	
	≥ 20,000 Btu/h		8.5 EER	
Room Air Conditioner Heat Pumps without Louvered Sides	< 14,000 Btu/h		8.5 EER	
	≥ 14,000 Btu/h		8.0 EER	
Room Air Conditioner, Casement Only	All Capacities		8.7 EER	

Room Air Conditioner, Casement – Slider	All Capacities		9.5 EER	
<p>^a Reserved.</p> <p>^b Cap means the rated cooling capacity of the product in Btu/h. If the unit's capacity is less than 7000 Btu/h, use 7000 Btu/h in the calculation. If the unit's capacity is greater than 15,000 Btu/h, use 15,000 Btu/h in the calculation.</p> <p>^c Replacement units must be factory labeled as follows: "MANUFACTURED FOR REPLACEMENT APPLICATIONS ONLY; NOT TO BE INSTALLED IN NEW CONSTRUCTION PROJECTS." Replacement efficiencies apply only to units with existing sleeves less than 16-in. high and less than 42-in. wide.</p> <p>^d Casement room air conditioners are not separate product classes under current minimum efficiency column.</p> <p>^e New room air conditioner standards, covered by NAECA became effective October 1, 2000.</p>				

Table 14-1E

Warm Air Furnaces and Combination Warm Air Furnaces/Air-Conditioning Units, Warm Air Duct Furnaces and Unit Heaters, Minimum Efficiency Requirements

Equipment Type	Size Category (Input)	Sub-Category or Rating Condition	Minimum Efficiency ^b	Test Procedure ^a
Warm Air Furnace, Gas-Fired	< 225,000 Btu/h (66 kW)		78% AFUE or 80% E _t ^c	DOE 10 CFR Part 430 or ANSI Z21.47
	≥ 225,000 Btu/h (66 kW)	Maximum Capacity ^c Minimum Capacity ^c	80% E _c ^f	ANSI Z21.47
Warm Air Furnace, Oil-Fired	< 225,000 Btu/h (66 kW)		78% AFUE or 80% E _t ^c	DOE 10 CFR Part 430 or UL 727
	≥ 225,000 Btu/h (66 kW)	Maximum Capacity ^b Minimum Capacity ^b	81% E _t ^g —	UL 727
Warm Air Duct Furnaces, Gas-Fired	All Capacities	Maximum Capacity ^b Minimum Capacity ^b	80% E _c ^e —	ANSI Z83.9
Warm Air Unit Heaters, Gas-Fired	All Capacities	Maximum Capacity ^b Minimum Capacity ^b	80% E _c ^e —	ANSI Z83.8
Warm Air Unit Heaters, Oil-Fired	All Capacities	Maximum Capacity ^b Minimum Capacity ^b	80% E _c ^e —	UL 731

^a Reserved.

^b Minimum and maximum ratings as provided for and allowed by the unit's controls.

^c Combination units not covered by NAECA (3-phase power or cooling capacity greater than or equal to 65,000 Btu/h [19 kW]) may comply with either rating.

^d E_t = Thermal efficiency. See test procedure for detailed discussion.

^e E_c = Combustion efficiency (100% less flue losses). See test procedure for detailed discussion.

^f E_c = Combustion efficiency. Units must also include an IID, have jacket losses not exceeding 0.75% of the input rating, and have either power venting or a flue damper. A vent damper is an acceptable alternative to a flue damper for those furnaces where combustion air is drawn from the conditioned space.

^g E_t = Thermal efficiency. Units must also include an IID, have jacket losses not exceeding 0.75% of the input rating, and have either power venting or a flue damper. A vent damper is an acceptable alternative to a flue damper for those furnaces where combustion air is drawn from the conditioned space.

Table 14-1F

Boilers, Gas- and Oil-Fired, Minimum Efficiency Requirements

Equipment Type ^f	Size Category	Sub-Category or Rating Condition	Minimum Efficiency ^b	Test Procedure
Boilers, Gas-Fired	< 300,000 Btu/h	Hot Water	80% AFUE	DOE 10 CFR Part 430
		Steam	75% AFUE	
	≥ 300,000 Btu/h and ≤ 2,500,000 Btu/h	Maximum Capacity ^b	75% E _t	H.I. Htg Boiler Std

	> 2,500,000 Btu/h ^f	Hot Water	80% E _c	
	> 2,500,000 Btu/h ^f	Steam	80% E _c	
Boilers, Oil-Fired	< 300,000 Btu/h		80% AFUE	DOE 10 CFR Part 430
	≥ 300,000 Btu/h and ≤ 2,500,000 Btu/h	Maximum Capacity ^b	78% E _t	H.I. Htg Boiler Std
	> 2,500,000 Btu/h ^f	Hot Water	83% E _c	
Oil-Fired (Residual)	> 2,500,000 Btu/h ^f	Steam	83% E _c	
	≥ 300,000 Btu/h and ≤ 2,500,000 Btu/h	Maximum Capacity ^b	78% E _t	H.I. Htg Boiler Std
	> 2,500,000 Btu/h ^f	Hot Water	83% E _c	
	> 2,500,000 Btu/h ^f	Steam	83% E _c	

^a Reserved.
^b Minimum and maximum ratings as provided for and allowed by the unit's controls.
^c E_c = Combustion efficiency (100% less flue losses). See reference document for detailed information.
^d E_t = Thermal efficiency. See reference document for detailed information.
^e Alternate test procedures used at the manufacturer's option are ASME PTC-4.1 for units over 5,000,000 Btu/h input, or ANSI Z21.13 for units greater than or equal to 300,000 Btu/h and less than or equal to 2,500,000 Btu/h input.
^f These requirements apply to boilers with rated input of 8,000,000 Btu/h or less that are not packaged boilers, and to all packaged boilers. Minimum efficiency requirements for boilers cover all capacities of packaged boilers.

Table 14-1G
Performance Requirements for Heat Rejection Equipment

Equipment Type	Total System Heat Rejection Capacity at Rated Conditions	Sub-Category or Rating Condition	Minimum Efficiency ^b	Test Procedure ^c
Propeller or Axial Fan Cooling Towers	All	95°F (35°C) Entering Water 85°F (29°C) Leaving Water 75°F (24°C) wb Outdoor Air	≥ 38.2 gpm/hp	CTI ATC-105 and CTI STD-201
Centrifugal Fan Cooling Towers	All	95°F (35°C) Entering Water 85°F (29°C) Leaving Water 75°F (24°C) wb Outdoor Air	≥ 20.0 gpm/hp	CTI ATC-105 and CTI STD-201
Air Cooled Condensers	All	125°F (52°C) Condensing Temperature R22 Test Fluid 190°F (88°C) Entering Gas Temperature 15°F (8°C) Subcooling 95°F (35°C) Entering Drybulb	≥ 176,000 Btu/h•hp	ARI 460

^a For purposes of this table, cooling tower performance is defined as the maximum flow rating of the tower divided by the fan nameplate rated motor power.
^b For purposes of this table air-cooled condenser performance is defined as the heat rejected from the refrigerant divided by the fan nameplate rated motor power.
^c Reserved.

TABLE 14-2 RESERVED

TABLE 14-3 RESERVED

TABLE 14-4
Energy Efficient Electric Motors
Minimum Nominal Full-Load Efficiency

Synchronous Speed (RPM)	Open Motors			Closed Motors		
	3,600	1,800	1,200	3,600	1,800	1,200
HP	Efficiency	Efficiency	Efficiency	Efficiency	Efficiency	Efficiency
1.0	-	82.5	80.0	75.5	82.5	80.0

Synchronous Speed (RPM)	Open Motors			Closed Motors		
	3,600	1,800	1,200	3,600	1,800	1,200
HP	Efficiency	Efficiency	Efficiency	Efficiency	Efficiency	Efficiency
1.5	82.5	84.0	84.0	82.5	84.0	85.5
2.0	84.0	84.0	85.5	84.0	84.0	86.5
3.0	84.0	86.5	86.5	85.5	87.5	87.5
5.0	85.5	87.5	87.5	87.5	87.5	87.5
7.5	87.5	88.5	88.5	88.5	89.5	89.5
10.0	88.5	89.5	90.2	89.5	89.5	89.5
15.0	89.5	91.0	90.2	90.2	91.0	90.2
20.0	90.2	91.0	91.0	90.2	91.0	90.2
25.0	91.0	91.7	91.7	91.0	92.4	91.7
30.0	91.0	92.4	92.4	91.0	92.4	91.7
40.0	91.7	93.0	93.0	91.7	93.0	93.0
50.0	92.4	93.0	93.0	92.4	93.0	93.0
60.0	93.0	93.6	93.6	93.0	93.6	93.6
75.0	93.0	94.1	93.6	93.0	94.1	93.6
100.0	93.0	94.1	94.1	93.6	94.5	94.1
125.0	93.6	94.5	94.1	94.5	94.5	94.1
150.0	93.6	95.0	94.5	94.5	95.0	95.0
200.0	94.5	95.0	94.5	95.0	95.0	95.0

TABLE 14-5
Duct Insulation

Duct Type	Duct Location	Insulation R-Value	Other Requirements
Supply, Return	Not within conditioned space: On exterior of building, on roof, in attic, in enclosed ceiling space, in walls, in garage, in crawl spaces	R-7	Approved weather proof barrier
Outside air intake	Within conditioned space	R-7	See Section 1414.2
Supply, Return, Outside air intake	Not within conditioned space: in concrete, in ground	R-5.3	
Supply with supply air temperature <55°F or >105°F	Within conditioned space	R-3.3	

Note: Requirements apply to the duct type listed, whether heated or mechanically cooled. Mechanically cooled ducts requiring insulation shall have a vapor retarder, with a perm rating not greater than 0.5 and all joints sealed.

TABLE 14-6
Minimum Pipe Insulation (inches)¹

Fluid Design Operating Temp. Range, °F	Insulation Conductivity		Nominal Pipe Diameter (in.)					
	Conductivity Range Btu • in. / (h • ft ² • °F)	Mean Rating Temp. °F	Runouts ² up to 2	1 and less	> 1 to 2	> 2 to 4	> 4 to 6	> 6
Heating systems (Steam, Steam Condensate[,] and Hot water)			Nominal Insulation Thickness					
Above 350	0.32-0.34	250	1.5	2.5	2.5	3.0	3.5	3.5
251-350	0.29-0.31	200	1.5	2.0	2.5	2.5	3.5	3.5
201-250	0.27-0.30	150	1.0	1.5	1.5	2.0	2.0	3.5
141-200	0.25-0.29	125	0.5	1.5	1.5	1.5	1.5	1.5
105-140	0.24-0.28	100	0.5	1.0	1.0	1.0	1.5	1.5
Domestic and Service Hot Water Systems								
105 and Greater	0.24-0.28	100	0.5	1.0	1.0	1.5	1.5	1.5
Cooling Systems (Chilled Water, Brine[,] and Refrigerant)								
40-55	0.23-0.27	75	0.5	0.5	0.75	1.0	1.0	1.0
Below 40	0.23-0.27	75	1.0	1.0	1.5	1.5	1.5	1.5

- Alternative Insulation Types. Insulation thicknesses in Table 14-6 are based on insulation with thermal conductivities within the range listed in Table 14-6 for each fluid operating temperature range, rated in accordance with ASTM C 335-84 at the mean temperature listed in the table. For insulation that has a conductivity outside the range shown in Table 14-6 for the applicable fluid operating temperature range at the mean rating temperature shown (when rounded to the nearest 0.01 Btu • in./(h•ft²•°F)), the minimum thickness shall be determined in accordance with the following equation:

$$T = PR[(1 + t/PR)^{K/k} - 1]$$

Where

- T = Minimum insulation thickness for material with conductivity K, inches.
- PR = Pipe actual outside radius, inches[.]
- t = Insulation thickness from Table 14-6, inches
- K = conductivity of alternate material at the mean rating temperature indicated in Table 14-6 for the applicable fluid temperature range, Btu • in.]/(h•ft² •°F)
- k = the lower value of the conductivity range listed in Table 14-6 for the applicable fluid temperature range, Btu • in.]/(h • ft² • °F)

- Runouts to individual terminal units not exceeding 12 ft. in length.

[Statutory Authority: RCW 19.27A.025, 19.27A.045, 02-01-112, § 51-11-1454, filed 12/18/01, effective 7/1/02; 01-03-010, § 51-11-1454, filed 1/5/01, effective 7/1/01; 98-03-003, § 51-11-1454, filed 1/8/98, effective 7/1/98. Statutory Authority: RCW 19.27A.025, 93-21-052, § 51-11-1454, filed 10/18/93, effective 4/1/94.]

[Statutory Authority: RCW 19.27A.025, 93-21-052, § 51-11-1501, filed 10/18/93, effective 4/1/94.]

Reviser's note: RCW 34.05.395 requires the use of underlining and deletion marks to indicate amendments to existing rules, and deems ineffectual changes not filed by the agency in this manner. The bracketed material in the above section does not appear to conform to the statutory requirement.

Reviser's note: The brackets and enclosed material in the text of the above section occurred in the copy filed by the agency.

WAC 51-11-1510 General requirements. Lighting and motors shall comply with Sections 1511 through 1513. Lighting systems shall comply with one of the following paths:

- a. Prescriptive Standards:
Interior Section 1521, or
Exterior Section 1522.
- b. Component Performance:
Interior Section 1531, or
Exterior Section 1532.
- c. Systems Analysis. See Section 1141.4.

The compliance path selected for interior and exterior lighting need not be the same. However, interior and exterior lighting cannot be traded.

CHAPTER 15 LIGHTING AND MOTORS

WAC 51-11-1501 Scope. Interior and exterior lighting and electric motors shall comply with the requirements of this chapter.

Figure 15A
Lighting and Motor Compliance Options

Section Number	Subject	Prescriptive Option	Lighting Power Allowance Option	Systems Analysis Option
1510	General Requirements	X	X	X
1511	Electric Motors	X	X	X
1512	Exempt Lighting	X	X	X
1513	Lighting Controls	X	X	X
1520	Prescriptive Lighting Option	X		
1521	Prescriptive Interior Lighting Requirements	X		
1522	Prescriptive Exterior Lighting Requirements	Sec. 1532		
1530	Lighting Power Allowance Option		X	
1531	Interior Lighting Power Allowance		X	
1532	Exterior Lighting Power Allowance		X	
RS-29	Systems Analysis			X

[Statutory Authority: RCW 19.27A.025, 93-21-052, § 51-11-1510, filed 10/18/93, effective 4/1/94.]

- EXCEPTIONS:**
1. Motors that are an integral part of specialized process equipment.
 2. Where the motor is integral to a listed piece of equipment for which no complying motor has been approved.

WAC 51-11-1511 Electric motors. All permanently wired polyphase motors of 1 hp or more, which are not part of an HVAC system, shall comply with Section 1437.

[Statutory Authority: RCW 19.27A.025, 93-21-052, § 51-11-1511, filed 10/18/93, effective 4/1/94.]

WAC 51-11-1512 Exempt lighting.

1512.1 Exempt Spaces: The following rooms, spaces, and areas, are exempt from the lighting power requirements in Sections 1520 and 1530 but shall comply with all other requirements of this chapter.

1. Areas in which medical or dental tasks are performed.
2. High risk security areas or any area identified by building officials as requiring additional lighting.
3. Spaces designed for primary use by the visually impaired, hard of hearing (lip-reading) or by senior citizens.
4. Food preparation areas.
5. Outdoor manufacturing, greenhouses, and processing areas.
6. Electrical/mechanical equipment rooms.
7. Outdoor athletic facilities.
8. Inspection and restoration areas in galleries and museums.
9. The sanctuary portion of a house of worship, defined as the space or room where the worship service takes place. Classrooms, meeting rooms, offices and multipurpose rooms that are part of the same facility are not exempt.

1512.2 Exempt Lighting Equipment: The following lighting equipment and tasks are exempt from the lighting requirements of Section 1520 and need not be included when calculating the installed lighting power under Section 1530 but shall comply with all other requirements of this chapter. All other lighting in areas that are not exempted by Section 1512.2, where exempt tasks and equipment are used, shall comply with all of the requirements of this chapter.

1. Special lighting needs for research.
2. Emergency lighting that is automatically OFF during normal building operation.
3. Lighting integral to signs, and permanently ballasted lighting fixtures for walkways and pathways.
4. Lighting that is part of machines, equipment or furniture.
5. Lighting that is used solely for indoor plant growth during the hours of 10:00 p.m. to 6:00 a.m.
6. Lighting for theatrical productions, television broadcasting (including sports facilities), audio-visual presentations, and special effects lighting for stage areas and dance floors in entertainment facilities.
7. Lighting for art exhibits, nonretail displays, portable plug in display fixtures, and show case lighting.
8. Exterior lighting for public monuments.

[Statutory Authority: RCW 19.27A.025, 19.27A.045. 01-03-010, § 51-11-1512, filed 1/5/01, effective 7/1/01; 98-03-003, § 51-11-1512, filed 1/8/98, effective 7/1/98. Statutory Authority: RCW 19.27A.025. 93-21-052, § 51-11-1512, filed 10/18/93, effective 4/1/94.]

WAC 51-11-1513 Lighting controls. Lighting, including exempt lighting in Section 1512, shall comply with this section. Where occupancy sensors are cited, they shall have the features listed in Section 1513.6.1. Where automatic time switches are cited, they shall have the features listed in Section 1513.6.2.

1513.1 Local Control and Accessibility: Each space, enclosed by walls or ceiling-height partitions, shall be provided with lighting controls located within that space. The lighting controls, whether one or more, shall be capable of turning off all lights within the space. The controls shall be readily accessible, at the point of entry/exit, to personnel occupying or using the space.

EXCEPTIONS: The following lighting controls may be centralized in remote locations:

1. Lighting controls for spaces which must be used as a whole.
2. Automatic controls.
3. Controls requiring trained operators.
4. Controls for safety hazards and security.

1513.2 Area Controls: The maximum lighting power that may be controlled from a single switch or automatic control shall not exceed that which is provided by a twenty ampere circuit loaded to not more than eighty percent. A master control may be installed provided the individual switches retain their capability to function independently. Circuit breakers may not be used as the sole means of switching.

EXCEPTIONS:

1. Industrial or manufacturing process areas, as may be required for production.
2. Areas less than five percent of footprint for footprints over 100,000 square feet.

1513.3 Daylight Zone Control: All daylighted zones, as defined in Chapter 2, both under overhead glazing and adjacent to vertical glazing, shall be provided with individual controls, or daylight-or occupant-sensing automatic controls, which control the lights independent of general area lighting.

Contiguous daylight zones adjacent to vertical glazing are allowed to be controlled by a single controlling device provided that they do not include zones facing more than two adjacent cardinal orientations (i.e. north, east, south, west). Daylight zones under overhead glazing more than 15 feet from the perimeter shall be controlled separately from daylight zones adjacent to vertical glazing.

EXCEPTION: Daylight spaces enclosed by walls or ceiling height partitions and containing 2 or fewer light fixtures are not required to have a separate switch for general area lighting.

1513.4 Display, Exhibition, and Specialty Lighting Controls: All display, exhibition, or specialty lighting shall be controlled independently of general area lighting.

1513.5 Automatic Shut-Off Controls, Exterior: Exterior lighting not intended for 24-hour continuous use shall be automatically switched by timer, photocell, or a combination of timer and photocell. Automatic time switches must also have program back-up capabilities, which prevent the loss of program and time settings for at least 10 hours, if power is interrupted.

1513.6 Automatic Shut-Off Controls, Interior: Office buildings greater than 5,000 sq. ft. and all school classrooms shall be equipped with separate automatic controls to shut off the lighting during unoccupied hours. Automatic controls may be an occupancy sensor, time switch, or other device capable of automatically shutting off lighting.

EXCEPTIONS:

1. Areas that must be continuously illuminated, or illuminated in a manner requiring manual operation of the lighting.
2. Emergency lighting systems.

3. Switching for industrial or manufacturing process facilities as may be required for production.

1513.6.1 Occupancy Sensors: Occupancy sensors shall be capable of automatically turning off all the lights in an area, no more than 30 minutes after the area has been vacated.

1513.6.2 Automatic Time Switches: Automatic time switches shall have a minimum 7 day clock and be capable of being set for 7 different day types per week and incorporate an automatic holiday "shut-off" feature, which turns off all loads for at least 24 hours and then resumes normally scheduled operations. Automatic time switches shall also have program back-up capabilities, which prevent the loss of program and time settings for at least 10 hours, if power is interrupted.

Automatic time switches shall incorporate an over-ride switching device which:

- a. is readily accessible;
- b. is located so that a person using the device can see the lights or the areas controlled by the switch, or so that the area being illuminated is annunciated; and
- c. is manually operated;
- d. allows the lighting to remain on for no more than two hours when an over-ride is initiated; and
- e. controls an area not exceeding 5,000 square feet or 5 percent of footprint for footprints over 100,000 square feet, whichever is greater.

1513.7 Commissioning Requirements: For lighting controls which include daylight or occupant sensing automatic controls, automatic shut-off controls, occupancy sensors, or automatic time switches, the lighting controls shall be tested to ensure that control devices, components, equipment and systems are calibrated, adjusted and operate in accordance with approved plans and specifications. Sequences of operation shall be functionally tested to ensure they operate in accordance with approved plans and specifications. A complete report of test procedures and results shall be prepared and filed with the owner. Drawing notes shall require commissioning in accordance with this paragraph.

[Statutory Authority: RCW 19.27A.025, 19.27A.045. 01-03-010, § 51-11-1513, filed 1/5/01, effective 7/1/01. Statutory Authority: RCW 19.27A.025. 93-21-052, § 51-11-1513, filed 10/18/93, effective 4/1/94.]

WAC 51-11-1520 Prescriptive lighting option.

[Statutory Authority: RCW 19.27A.025. 93-21-052, § 51-11-1520, filed 10/18/93, effective 4/1/94.]

WAC 51-11-1521 Prescriptive interior lighting requirements. Spaces for which the Unit Lighting Power Allowance in Table 15-1 is 0.8 watts per square foot or greater may use unlimited numbers of lighting fixtures and lighting energy, provided that the installed lighting fixtures comply with all four of the following criteria:

- a. one- or two-lamp (but not three- or more lamp);
- b. nonlensed, fluorescent fixtures;
- c. fitted with type T-1, T-2, T-4, T-5, T-6, T-8 or compact fluorescent lamps from 5 to 50 watts (but not T-10 or T-12 lamps); and
- d. electronic ballasts (electronic ballasts that screw into medium base sockets do not comply with this section).

EXCEPTIONS:

1. Up to a total of 5 percent of installed lighting fixtures need not be ballasted and may use any type of lamp.
2. Clear safety lenses are allowed in food prep and serving areas and patient care areas in otherwise compliant fixtures.
3. Exit lights are not included in the count of fixtures provided that they do not exceed 5 watts per fixture and are light emitting diode (LED) type or T-1 fluorescent type only. (See the Uniform Fire Code for face illumination footcandle requirements and other requirements.)

[Statutory Authority: RCW 19.27A.025, 19.27A.045. 01-03-010, § 51-11-1521, filed 1/5/01, effective 7/1/01. Statutory Authority: RCW 19.27A.025. 93-21-052, § 51-11-1521, filed 10/18/93, effective 4/1/94.]

WAC 51-11-1522 Prescriptive exterior lighting requirements. See section 1532.

[Statutory Authority: RCW 19.27A.025. 93-21-052, § 51-11-1522, filed 10/18/93, effective 4/1/94.]

WAC 51-11-1530 Lighting power allowance option.

The installed lighting wattage shall not exceed the lighting power allowance. Lighting wattage includes lamp and ballast wattage. Wattage for fluorescent lamps and ballasts shall be tested per ANSI Standard C82.2-1984.

The wattage used for any unballasted fixture shall be the maximum UL listed wattage for that fixture regardless of the lamp installed. The wattage used for track lighting shall be:

- a. for line voltage track, 50 watts per lineal foot of track or actual luminaire wattage, whichever is greater
- b. for low voltage track, 25 watts per lineal foot of track or the VA rating of the transformer, whichever is greater.

No credit towards compliance with the lighting power allowances shall be given for the use of any controls, automatic or otherwise.

Exit lights that are 5 watts or less per fixture shall not be included in the lighting power allowance calculations. Other exit lights shall be included in the lighting power allowance calculations.

[Statutory Authority: RCW 19.27A.025, 19.27A.045. 01-03-010, § 51-11-1530, filed 1/5/01, effective 7/1/01; 98-03-003, § 51-11-1530, filed 1/8/98, effective 7/1/98. Statutory Authority: RCW 19.27A.025. 93-21-052, § 51-11-1530, filed 10/18/93, effective 4/1/94.]

WAC 51-11-1531 Interior lighting power allowance.

The interior lighting power allowance shall be calculated by multiplying the gross interior floor area, in square feet, by the appropriate unit lighting power allowance, in watts per square foot, for the use as specified in Table 15-1. Accessory uses, including corridors, lobbies and toilet facilities shall be included with the primary use.

The lighting power allowance for each use shall be separately calculated and summed to obtain the interior lighting power allowance.

In cases where a lighting plan for only a portion of a building is submitted, the interior lighting power allowance shall be based on the gross interior floor area covered by the plan. Plans submitted for common areas only, including corridors, lobbies and toilet facilities shall use the lighting power allowance for common areas in Table 15-1.

When insufficient information is known about the specific use of the space, the allowance shall be based on the apparent intended use of the space.

[Statutory Authority: RCW 19.27A.025, 19.27A.045. 01-03-010, § 51-11-1531, filed 1/5/01, effective 7/1/01. Statutory Authority: RCW 19.27A.025. 93-21-052, § 51-11-1531, filed 10/18/93, effective 4/1/94.]

WAC 51-11-1532 Exterior lighting power allowance.

The exterior lighting power allowance shall be the sum of the calculated allowances for parking, outdoor areas and building exteriors. The lighting allowance for covered parking, open parking and outdoor areas that are illuminated shall be 0.20 watts per square foot. The lighting allowance for building exteriors shall be calculated either by multiplying the building facade area by 0.25 watts per square foot or multiplying the building perimeter in feet by 7.5 watts per linear foot.

- EXCEPTIONS:
1. Group U Occupancy accessory to Group R-3 Occupancy.
 2. For covered parking, 0.30 w/sf may be used for the lighting provided that the ceilings and walls are painted or stained with a reflectance value of 0.70 or higher.

TABLE 15-1
Unit Lighting Power Allowance (LPA)

Use ¹	LPA ² (watts/sq. ft.)
Painting, welding, carpentry, machine shops	2.3
Barber shops, beauty shops	2.0
Hotel banquet/conference/exhibition hall ^{3,4}	2.0
Laboratories	2.0
Aircraft repair hangars	1.5
Cafeterias, fast food establishments ⁵	1.5
Factories, workshops, handling areas	1.5
Gas stations, auto repair shops ⁶	1.5
Institutions	1.5
Libraries ⁵	1.5
Nursing homes and hotel/motel guest rooms	1.5
Retail ¹⁰ , retail banking	1.5
Wholesale stores (pallet rack shelving)	1.5
Mall concourses	1.4
Schools buildings (Group E Occupancy only), school classrooms, day care centers	1.35
Laundries	1.3
Office buildings, office/administrative areas in facilities of other use types (including but not limited to schools, hospitals, institutions, museums, banks, churches) ^{5,7,11}	1.2
Police and fire stations ⁸	1.2
Atria (atriums)	1.0
Assembly spaces ⁹ , auditoriums, gymnasias ⁹ , theaters	1.0
Group R-1 common areas	1.0
Process plants	1.0
Restaurants/bars ⁵	1.0
Locker and/or shower facilities	0.8
Warehouses ¹¹ , storage areas	0.5
Aircraft storage hangars	0.4
Parking garages	See Section 1532

Use ¹	LPA ² (watts/sq. ft.)
Plans Submitted for Common Areas Only⁷	
Main floor building lobbies ³ (except mall concourses)	1.2
Common areas, corridors, toilet facilities and wash-rooms, elevator lobbies	0.8

Footnotes for Table 15-1

1. In cases in which a general use and a specific use are listed, the specific use shall apply. In cases in which a use is not mentioned specifically, the *Unit Power Allowance* shall be determined by the building official. This determination shall be based upon the most comparable use specified in the table. See Section 1512 for exempt areas.
2. The watts per square foot may be increased, by two percent per foot of ceiling height above twenty feet, unless specifically directed otherwise by subsequent footnotes.
3. Watts per square foot of room may be increased by two percent per foot of ceiling height above twelve feet.
4. For all other spaces, such as seating and common areas, use the *Unit Light Power Allowance* for assembly.
5. Watts per square foot of room may be increased by two percent per foot of ceiling height above nine feet.
6. Includes pump area under canopy.
7. In cases in which a lighting plan is submitted for only a portion of a floor, a *Unit Lighting Power Allowance* of 1.35 may be used for usable office floor area and 0.80 watts per square foot shall be used for the common areas, which may include elevator space, lobby area and rest rooms. Common areas, as herein defined do not include mall concourses.
8. For the fire engine room, the *Unit Lighting Power Allowance* is 1.0 watts per square foot.
9. For indoor sport tournament courts with adjacent spectator seating, the *Unit Lighting Power Allowance* for the court area is 2.6 watts per square foot.
10. Display window illumination installed within 2 feet of the window, lighting for free-standing display where the lighting moves with the display, and building showcase illumination where the lighting is enclosed within the showcase are exempt.
An additional 1.5 w/ft² of merchandise display luminaires are exempt provided that they comply with all three of the following:
 - (a) located on ceiling-mounted track or directly on or recessed into the ceiling itself (not on the wall).
 - (b) adjustable in both the horizontal and vertical axes (vertical axis only is acceptable for fluorescent and other fixtures with two points of track attachment).
 - (c) fitted with tungsten halogen, fluorescent, or high intensity discharge lamps.
11. Provided that a floor plan, indicating rack location and height, is submitted, the square footage for a warehouse may be defined, for computing the interior *Unit Lighting*

Power Allowance, as the floor area not covered by racks plus the vertical face area (access side only) of the racks. The height allowance defined in footnote 2 applies only to the floor area not covered by racks.

[Statutory Authority: RCW 19.27A.025, 19.27A.045, 01-03-010, § 51-11-1532, filed 1/5/01, effective 7/1/01. Statutory Authority: RCW 19.27A.025, 93-21-052, § 51-11-1532, filed 10/18/93, effective 4/1/94.]

CHAPTER 16 (RESERVED)

CHAPTER 17 STANDARDS

Note: For nonresidential standards, see chapter 7.

CHAPTER 18 (RESERVED)

CHAPTER 19 (RESERVED)

CHAPTER 20 DEFAULT HEAT-LOSS COEFFICIENTS

Note: For nonresidential defaults, see chapter 10.

REFERENCE STANDARD NONRESIDENTIAL BUILDING DESIGN BY SYSTEMS ANALYSIS

WAC 51-11-99901 Section 1—Scope.

1.1 General: This Standard establishes design criteria in terms of total energy consumption of a building, including all of its systems. General principles and requirements are outlined in Section 2. Specific modeling assumptions are listed in Section 3.

The building permit application for projects utilizing this Standard shall include in one submittal all building and mechanical drawings and all information necessary to verify that the design for the project corresponds with the annual energy analysis. If credit is proposed to be taken for lighting energy savings, then electrical drawings shall also be included with the building permit application.

Due to the various assumptions that are necessary, the results of the analysis shall not be construed as a guarantee of the actual energy performance of the project.

[Statutory Authority: RCW 19.27A.025, 93-21-052, § 51-11-99901, filed 10/18/93, effective 4/1/94.]

WAC 51-11-99902 Section 2—General principles and requirements.

2.1 Energy Analysis: Compliance with this Standard will require an analysis of the annual energy usage, hereinafter called an annual energy analysis.

A building designed in accordance with this Standard will be deemed as complying with this Code, if

a. The calculated annual energy consumption is not greater than that of a corresponding "standard design," as defined below and in Section 3,

and;

b. Whose enclosure elements and energy-consuming systems comply with Sections 1310 through 1314, 1410 through 1416, 1440 through 1443, 1450 through 1454 and 1510 through 1513. Buildings shall only vary from those requirements in Sections 1330 through 1334, 1432 through 1439 and 1530 through 1532 where those variations have been accurately and completely modeled. Where variations are not specifically analyzed, the building shall comply with these requirements.

For a proposed building design to be considered similar to a "standard design," it shall utilize the same energy source(s) for the same functions and have equal floor area and the same ratio of envelope area to floor area, environmental requirements, occupancy, climate data and usage operational schedule. Inputs to the energy analysis relating to occupancy and usage shall correspond to the expected occupancy and usage of the building.

Except as noted below, the systems identified, and, to the extent possible, the assumptions made in assigning energy inputs to each system, shall be the same for the standard design and the proposed design. When electrically driven heat pumps, other than multiple units connected to a common water loop, are employed to provide all or part of the heat for the proposed design, the standard design shall also, for the purposes of the analysis, assume that electrically driven heat pump, in conformance with Chapter 14 of the Code and having capacity at least as great as those used in the proposed design are employed.

2.2 Design: The standard design and the proposed design shall be designed on a common basis as specified herein:

a. The comparison shall be expressed as kBtu input per square foot of conditioned floor area per year at the building site. Buildings which use electricity as the only fuel source, comparisons may be expressed in kWh. When converting electricity in kWh to kBtu a multiplier of 3.413 kWh/kBtu shall be used.

b. If the proposed design results in an increase in consumption of one energy source and a decrease in another energy source, even though similar sources are used for similar purposes, the difference in each energy source shall be converted to equivalent energy units for purposes of comparing the total energy used.

2.3 Analysis Procedure: The analysis of the annual energy usage of the standard and the proposed building and system design shall meet the following criteria:

a. The building heating/cooling load calculation procedure used for annual energy consumption analysis shall be detailed to permit the evaluation of effect of factors specified in Section 2.4.

b. The calculation procedure used to simulate the operation of the building and its service systems through a full-year operating period shall be detailed to permit the evaluation of the effect of system design, climatic factors, operational char-

acteristics and mechanical equipment on annual energy usage. Manufacturer's data or comparable field test data shall be used when available in the simulation of systems and equipment. The calculation procedure shall be based upon 8,760 hours of operation of the building and its service systems and shall utilize the design methods, specified in Standards RS-27, -11, -12 and -13 listed in Chapter 7 of the Code or in other programs approved by the building official.

2.4 Calculation Procedure: The calculation procedure shall cover the following items:

- a. Design requirements—Design heating conditions and design cooling conditions as defined in Chapter 2 of the Code.
- b. Climatic data—Coincident hourly data for temperatures, solar radiation, wind and humidity of typical days in the year representing seasonal variation.
- c. Building data—Orientation, size, shape, mass, air and heat transfer characteristics.
- d. Operational characteristics—Temperature, humidity, ventilation, illumination and control mode for occupied and unoccupied hours.
- e. Mechanical equipment—Design capacity and part load profile.
- f. Building loads—Internal heat generation, lighting, equipment and number of people during occupied and unoccupied periods.

2.5 Documentation: All analyses submitted shall be accompanied by an energy analysis comparison report. The report shall provide technical detail on the two building and system designs and on the data used in and resulting from the comparative analysis to verify that both the analysis and the designs meet the criteria of Section 1.

The calculation procedure for the standard design and the proposed design shall separately identify the calculated annual energy consumption for each different occupancy type, if possible, for each of the following end uses:

- a. Interior lighting;
- b. Parking lighting;
- c. Exterior lighting;
- d. Space heating;
- e. Space cooling;
- f. Interior ventilation/fans;
- g. Parking ventilation/fans;
- h. Exhaust fans;
- i. Service water heating;
- j. Elevators;
- k. Appliances.

Energy consumption of the following items shall be included but is not required to be separated out by each individual item.

- a. Office equipment;
- b. Refrigeration other than comfort cooling;
- c. Cooking; and
- d. Any other energy-consuming equipment.

The specifications of the proposed building project used in the analysis shall be as similar as is reasonably practical to those in the plans submitted for a building permit.

[Statutory Authority: RCW 19.27A.025, 19.27A.045, 01-03-010, § 51-11-99902, filed 1/5/01, effective 7/1/01. Statutory Authority: RCW 19.27A.025, 93-21-052, § 51-11-99902, filed 10/18/93, effective 4/1/94.]

WAC 51-11-99903 Section 3—Specific modeling assumptions.

The specific modeling assumptions consist of methods and assumptions for calculating the standard energy consumption for the standard building and the proposed energy consumption of the proposed design. In order to maintain consistency between the standard and the proposed design energy consumptions, the input assumptions in this section shall be used.

"Prescribed" assumptions shall be used without variation. "Default" assumptions shall be used unless the designer can demonstrate that a different assumption better characterizes the building's use over its expected life. Any modification of a default assumption shall be used in modeling both the standard building and the proposed design unless the designer demonstrates a clear cause to do otherwise.

3.1 Orientation and Shape: The standard building shall consist of the same number of stories and gross floor area for each story as the proposed design. Each floor shall be oriented exactly as the proposed design. The geometric form shall be the same as the proposed design.

3.2 Internal Loads: Internal loads shall be modeled as noted in the following parts of Section 3.2. The systems specified for calculating the standard energy consumption in Section 3.2 are intended only as constraints in calculating the consumption. They are not intended as requirements or recommendations for systems to be used in the proposed building or for the calculation of the proposed energy consumption.

3.2.1 Occupancy: Occupancy schedules shall be default assumptions. The same assumptions shall be made in computing proposed energy consumption as were used in calculating the standard energy consumption. Occupancy levels vary by building type and time of day. Table 3-1 establishes the density presented as ft²/person of conditioned floor area that will be used by each building type. Table 3-2 establishes the percentage of the people that are in the building by hours of the day for each building type.

3.2.2 Lighting: The interior and exterior lighting power allowance for calculating the standard energy consumption shall be determined from Sections 1531 and 1532. The lighting power used to calculate the proposed energy consumption shall be the actual lighting power of the proposed lighting design. Exempt lighting in the standard design shall be equal to the exempt lighting in the proposed design.

Lighting levels in buildings vary based on the type of uses within buildings, by area and by time of day. Table 3-2 contains the lighting energy profiles which establish the percentage of the lighting load that is switched ON in each prototype or reference building by hour of the day. These pro-

files are default assumptions and can be changed if required when calculating the standard energy consumption to provide, for example, a 12 hour rather than an 8 hour work day or to reflect the use of automatic lighting controls. The lighting schedules used in the standard and proposed designs shall be identical and shall reflect the type of controls to be installed in the proposed design. The controls in the proposed design shall comply with the requirements in Section 1513 and no credit shall be given for the use of any additional controls, automatic or otherwise.

3.2.3 Receptacle: Receptacle loads and profiles are default assumptions. The same assumptions shall be made in calculating proposed energy consumption as were used in calculating the standard energy consumption. Receptacle loads include all general service loads that are typical in a building. These loads should include additional process electrical usage but exclude HVAC primary or auxiliary electrical usage. Table 3-1 establishes the density in W/ft² to be used. The receptacle energy profiles shall be the same as the lighting energy profiles in Table 3-2. This profile establishes the percentage of the receptacle load that is switched ON by hour of the day and by building type.

3.3 Envelope

3.3.1 Insulation and Glazing: Glazing area and U-factor of the standard building envelope shall be determined by using the Target UA requirements of Equation 13-1 and U-factor values in Table 13-1 or 13-2. The glazing solar heat gain coefficient (SHGC) or shading coefficient of the standard building shall be the lesser of 0.65 and the SHGC required by Table 13-1 or 13-2 for the vertical or overhead glazing area for the appropriate wall type. The opaque area U-factors of the standard building shall be determined by using the Target UA requirements from Equation 13-1 including the appropriate mass for walls. The insulation characteristics and glazing area are prescribed assumptions for the standard building for calculating the standard energy consumption. In the calculation of the proposed energy consumption of the proposed design, the envelope characteristics of the proposed design shall be used. The standard design shall use the maximum glazing areas listed in Tables 13-1 or 13-2 for the appropriate use. The distribution of vertical glazing in the gross wall area of the standard design shall be equal to the distribution of vertical glazing in the proposed design or shall constitute an equal percentage of gross wall area on all sides of the standard building. The distribution of overhead glazing in the gross roof/ceiling area of the standard design shall be equal to the distribution of overhead glazing in the proposed design. The distribution of doors in the gross opaque wall area of the standard design shall be identical to the distribution of doors in the proposed design.

3.3.2 Infiltration: For standard and proposed buildings, infiltration assumptions shall be equal.

3.3.3 Envelope and Ground Absorptivities: For the standard building, absorptivity assumptions shall be default assumptions for computing the standard energy consumption and default assumptions for computing the proposed energy consumption. The solar absorptivity of opaque elements of

the building envelope shall be assumed to be 70 percent. The solar absorptivity of ground surfaces shall be assumed to be 80 percent (20 percent reflectivity).

3.3.4 Window Treatment: No draperies or blinds shall be modeled for the standard or proposed building.

3.3.5 Shading: For standard building and the proposed design, shading by permanent structures and terrain shall be taken into account for computing energy consumption whether or not these features are located on the building site. A permanent fixture is one that is likely to remain for the life of the proposed design. Credit may be taken for external shading devices that are part of the proposed design.

3.4 HVAC Systems and Equipment: For the standard building, the HVAC system used shall be the system type used in the proposed design. If the proposed HVAC system type does not comply with Sections 1432 through 1439, the standard design system shall comply in all respects with those sections.

EXCEPTION:

When approved by the building official, a prototype HVAC system may be used, if the proposed design system cannot be modified to comply with Sections 1422 and 1432 through 1439, as a standard design. Use of prototype HVAC systems shall only be permitted for the building types listed below. For mixed-use buildings, the floor space of each building type is allocated within the floor space of the standard building. The specifications and requirements for the HVAC systems of prototype buildings shall be those in Table 3-3.

- | | |
|-------------------------|-------------------------|
| 1. assembly | 6. restaurant |
| 2. health/institutional | 7. retail (mercantile) |
| 3. hotel/motel | 8. school (educational) |
| 4. light manufacturing | 9. warehouse (storage) |
| 5. office (business) | |

3.4.1 HVAC Zones: HVAC zones for calculating the standard energy consumption and proposed energy consumption shall consist of at least four perimeter and one interior zone per floor, with at least one perimeter zone facing each orientation. The perimeter zones shall be fifteen feet in width or one-third the narrow dimension of the building when this dimension is between 30 and 45 feet inclusive or half the narrow dimension of the building when this dimension is less than thirty feet.

EXCEPTIONS:

1. Building types such as assembly or warehouse may be modeled as a single zone if there is only one space.
2. Thermally similar zones, such as those facing one orientation on different floors, may be grouped together for the purposes of either the standard or proposed building simulation.

3.4.2 Process Equipment Sizing: Process sensible and latent loads shall be equal in calculating both the standard energy consumption and the proposed energy consumption. The designer shall document the installation of process equipment and the size of process loads.

3.4.3 HVAC Equipment Sizing: The equipment shall be sized to include the capacity to meet the process loads. For calculating the proposed energy consumption, actual air flow rates and installed equipment size shall be used in the simulation. Equipment sizing in the simulation of the proposed design shall correspond to the equipment intended to be

selected for the design and the designer shall not use equipment sized automatically by the simulation tool.

Equipment sizing for the standard design shall be based on the same as the proposed design or lesser sizing ratio of installed system capacity to the design load for heating and for cooling.

Chilled water systems for the standard building shall be modeled using a reciprocating chiller for systems with total cooling capacities less than 175 tons, and centrifugal chillers for systems with cooling capacities of 175 tons or greater. For systems with cooling capacities of 600 tons or more the standard energy consumption shall be calculated using two centrifugal chillers, lead/lag controlled. Chilled water shall be assumed to be controlled at a constant 44 degree F temperature rise, from 44 degrees F to 56 degrees F, operating at 65 percent combined impeller and motor efficiency. Condenser water pumps shall be sized using a 10 degree F temperature rise, operating at 60 percent combined impeller and motor efficiency. The cooling tower shall be an open circuit, centrifugal blower type sized for the larger of 85 degrees F leaving water temperature or 10 degrees F approach to design wet-bulb temperature. The tower shall be controlled to provide a 65 degrees F leaving water temperature whenever weather conditions permit, floating up to design leaving water temperature at design conditions.

3.4.4 Fans: The power of the combined fan system per air volume at design conditions (w/cfm) of the proposed design shall be equal to that of the standard design.

Variable air volume fan systems in the standard building shall be variable speed.

3.5 Service Water Heating: The service water heating loads for prototype buildings are defined in terms of Btu/person-hour in Table 3-1. The values in the table refer to energy content of the heated water. The service water heating loads from Table 3-1 are default for all buildings. The same service-water-heating load assumptions shall be made in calculating proposed energy consumption as were used in calculating the standard energy consumption. The service water heating system for the standard building shall be modeled as closely as possible as if it were designed in accordance with RS-11 and meeting all the requirements of Sections 1440 through 1443.

3.6 Controls

3.6.1: All occupied conditioned spaces in standard and proposed design buildings in all climates shall be simulated as being both heated and cooled.

EXCEPTIONS:

1. If a building or portion of a building is to be provided with only heating or cooling, both the standard building and the proposed design shall be simulated using the same assumptions.
2. If warehouses are not intended to be mechanically cooled, both the standard and proposed energy consumption shall be modeled assuming no mechanical cooling.

3.6.2: Space temperature controls for the standard building, shall be set at 70 degrees F for space heating and 75 degrees F for space cooling, with a deadband in accordance with Section 1412.2. The system shall be OFF during off-hours according to the appropriate schedule in Table 3-2, except

[Title 51 WAC—p. 100]

that the heating system shall cycle ON if any space should drop below the night setback setting 55 degrees F. There shall be no similar setpoint during the cooling season. Lesser deadband ranges may be used in calculating the proposed energy consumption.

EXCEPTIONS:

1. Setback shall not be modeled in determining either the standard or proposed energy consumption if setback is not realistic for the proposed design such as a facility being operated 24 hours/day. For instance, health facilities need not have night setback during the heating season.
2. If deadband controls are not to be installed, the proposed energy consumption shall be calculated with both heating and cooling thermostat setpoints set to the same value between 70 degrees F and 75 degrees F inclusive, assumed to be constant for the year.

3.6.3: When providing for outdoor air ventilation when calculating the standard energy consumption, controls shall be assumed to close the outside air intake to reduce the flow of outside air to 0.0 cfm during "setback" and "unoccupied" periods. Ventilation using inside air may still be required to maintain scheduled setback temperature. Outside air ventilation, during occupied periods, shall be as required by the Washington State Ventilation and Indoor Air Quality Code chapter 51-13 WAC.

3.6.4: If humidification is to be used in the proposed design, the same level of humidification and system type shall be used in the standard building.

TABLE 3-1
Acceptable Occupancy Densities, Receptacle Power Densities and Service Hot Water Consumption¹

Building Type	Occupancy Density ² Sq. Ft./Person (Btu/h•ft ²)	Receptacle Power Density ³ Watts/Sq. Ft. (Btu/h•ft ²)	Service Hot Water Quantities ⁴ Btu/h•person
Assembly	50 (4.60)	0.25 (0.85)	215
Health/Institutional	200 (1.15)	1.00 (3.41)	135
Hotel/Motel	250 (0.92)	0.25 (0.85)	1,110
Light Manufacturing	750 (0.31)	0.20 (0.68)	225
Office	275 (0.84)	0.75 (2.56)	175
Parking Garage	N.A.	N.A.	N.A.
Restaurant	100 (2.30)	0.10 (0.34)	390
Retail	300 (0.77)	0.25 (0.85)	135
School	75 (3.07)	0.50 (1.71)	215
Warehouse	15,000 (0.02)	0.10 (0.34)	225

1. The occupancy densities, receptacle power densities and service hot water consumption values are from ASHRAE Standard 90.1-1989 and addenda.
2. Values are in square feet of conditioned floor area per person. Heat generation in Btu per person per hour is 230 sensible and 190 latent. Figures in parentheses are equivalent Btu per hour per square foot.
3. Values are in Watts per square foot of conditioned floor area. Figures in parentheses are equivalent Btu per hour per square foot. These values are the minimum acceptable. If other process loads are not input (such as for computers, cooking, refrigeration, etc.), it is recommended that receptacle power densities be increased until total process energy consumption is equivalent to 25% of the total.
4. Values are in Btu per person per hour.

TABLE 3-2A
Assembly Occupancy¹

Hour of Day (time)	Schedule for Occupancy			Schedule for Lighting Receptacle			Schedule for HVAC System			Schedule for Service Hot Water			Schedule for Elevator		
	Percent of Maximum Load			Percent of Maximum Load						Percent of Maximum Load			Percent of Maximum Load		
	Wk	Sat	Sun	Wk	Sat	Sun	Wk	Sat	Sun	Wk	Sat	Sun	Wk	Sat	Sun
1 (12-1am)	0	0	0	5	5	5	off	off	off	0	0	0	0	0	0
2 (1-2am)	0	0	0	5	5	5	off	off	off	0	0	0	0	0	0
3 (2-3am)	0	0	0	5	5	5	off	off	off	0	0	0	0	0	0
4 (3-4am)	0	0	0	5	5	5	off	off	off	0	0	0	0	0	0
5 (4-5am)	0	0	0	5	5	5	off	off	off	0	0	0	0	0	0
6 (5-6am)	0	0	0	5	5	5	on	off	off	0	0	0	0	0	0
7 (6-7am)	0	0	0	40	5	5	on	on	on	0	0	0	0	0	0
8 (7-8am)	0	0	0	40	30	30	on	on	on	0	0	0	0	0	0
9 (8-9am)	20	20	10	40	30	30	on	on	on	0	0	0	0	0	0
10 (9-10am)	20	20	10	75	50	30	on	on	on	5	5	5	0	0	0
11 (10-11am)	20	20	10	75	50	30	on	on	on	5	5	5	0	0	0
12 (11-12pm)	80	60	10	75	50	30	on	on	on	35	20	10	0	0	0
13 (12-1pm)	80	60	10	75	50	65	on	on	on	5	0	0	0	0	0
14 (1-2pm)	80	60	70	75	50	65	on	on	on	5	0	0	0	0	0
15 (2-3pm)	80	60	70	75	50	65	on	on	on	5	0	0	0	0	0
16 (3-4pm)	80	60	70	75	50	65	on	on	on	5	0	0	0	0	0
17 (4-5pm)	80	60	70	75	50	65	on	on	on	5	0	0	0	0	0
18 (5-6pm)	80	60	70	75	50	65	on	on	on	0	0	0	0	0	0
19 (6-7pm)	20	60	70	75	50	65	on	on	on	0	0	0	0	0	0
20 (7-8pm)	20	60	70	75	50	65	on	on	on	0	65	65	0	0	0
21 (8-9pm)	20	60	70	75	50	65	on	on	on	0	30	30	0	0	0
22 (9-10pm)	20	80	70	75	50	65	on	on	on	0	0	0	0	0	0
23 (10-11pm)	10	10	20	25	50	5	on	on	on	0	0	0	0	0	0
24 (11-12am)	0	0	0	5	5	5	off	off	off	0	0	0	0	0	0
Total/Day	710	750	700	1155	800	845	1800	1700	1700	70	125	115	0	0	0
Total/Week		50.50	hours		74.20	hours					5.9	hours		0	hours
Total/Year		2633	hours		3869	hours					308	hours		0	hours

Wk = Weekday

1. Schedules for occupancy, lighting, receptacle, HVAC system and service hot water are from ASHRAE Standard 90.1-1989 and addendums, except that 5% emergency lighting has been added for all off hours. Elevator schedules, except for restaurants, are from the U.S. Department of Energy Standard Evaluation Techniques except changed to 0% when occupancy is 0%. THESE VALUES MAY BE USED ONLY IF ACTUAL SCHEDULES ARE NOT KNOWN.

TABLE 3-2B
Health Occupancy¹

Hour of Day (time)	Schedule for Occupancy			Schedule for Lighting Receptacle			Schedule for HVAC System			Schedule for Service Hot Water			Schedule for Elevator		
	Percent of Maximum Load			Percent of Maximum Load						Percent of Maximum Load			Percent of Maximum Load		
	Wk	Sat	Sun	Wk	Sat	Sun	Wk	Sat	Sun	Wk	Sat	Sun	Wk	Sat	Sun
1 (12-1am)	0	0	0	10	10	5	on	on	on	1	1	1	0	0	0
2 (1-2am)	0	0	0	10	10	5	on	on	on	1	1	1	0	0	0
3 (2-3am)	0	0	0	10	10	5	on	on	on	1	1	1	0	0	0
4 (3-4am)	0	0	0	10	10	5	on	on	on	1	1	1	0	0	0
5 (4-5am)	0	0	0	10	10	5	on	on	on	1	1	1	0	0	0
6 (5-6am)	0	0	0	10	10	5	on	on	on	1	1	1	0	0	0
7 (6-7am)	0	0	0	10	10	5	on	on	on	1	1	1	0	0	0
8 (7-8am)	10	10	0	50	20	5	on	on	on	17	1	1	2	2	0
9 (8-9am)	50	30	5	90	40	10	on	on	on	58	20	1	75	46	2
10 (9-10am)	80	40	5	90	40	10	on	on	on	66	28	1	100	70	2
11 (10-11am)	80	40	5	90	40	10	on	on	on	78	30	1	100	70	2
12 (11-12pm)	80	40	5	90	40	10	on	on	on	82	30	1	100	70	2
13 (12-1pm)	80	40	5	90	40	10	on	on	on	71	24	1	75	51	2
14 (1-2pm)	80	40	5	90	40	10	on	on	on	82	24	1	100	51	2
15 (2-3pm)	80	40	5	90	40	10	on	on	on	78	23	1	100	51	2
16 (3-4pm)	80	40	5	90	40	10	on	on	on	74	23	1	100	51	2
17 (4-5pm)	80	40	0	30	40	5	on	on	on	63	23	1	100	51	0
18 (5-6pm)	50	10	0	30	40	5	on	on	on	41	10	1	100	25	0
19 (6-7pm)	30	10	0	30	10	5	on	on	on	18	1	1	52	2	0

Hour of Day (time)	Schedule for Occupancy			Schedule for Lighting Receptacle			Schedule for HVAC System			Schedule for Service Hot Water			Schedule for Elevator			
	Percent of Maximum Load			Percent of Maximum Load						Percent of Maximum Load			Percent of Maximum Load			
	Wk	Sat	Sun	Wk	Sat	Sun	Wk	Sat	Sun	Wk	Sat	Sun	Wk	Sat	Sun	
20 (7-8pm)	30	0	0	30	10	5	on	on	on	18	1	1	52	0	0	
21 (8-9pm)	20	0	0	30	10	5	on	on	on	18	1	1	52	0	0	
22 (9-10pm)	20	0	0	30	10	5	on	on	on	10	1	1	28	0	0	
23 (10-11pm)	0	0	0	30	10	5	on	on	on	1	1	1	0	0	0	
24 (11-12am)	0	0	0	10	10	5	on	on	on	1	1	1	0	0	0	
Total/Day	850	380	40	1060	550	160	2400	2400	2400	783	249	24	1136	540	16	
Total/Week		46.70	hours		60.10	hours			168	hours		41.88	hours		62.36	hours
Total/Year		2435	hours		3134	hours			8760	hours		2148	hours		3251	hours

Wk = Weekday

- Schedules for occupancy, lighting, receptacle, HVAC system and service hot water are from ASHRAE Standard 90.1-1989 and addendums, except that 5% emergency lighting has been added for all off hours. Elevator schedules, except for restaurants, are from the U.S. Department of Energy Standard Evaluation Techniques except changed to 0% when occupancy is 0%. THESE VALUES MAY BE USED ONLY IF ACTUAL SCHEDULES ARE NOT KNOWN.

TABLE 3-2C
Hotel/Motel Occupancy¹

Hour of Day (time)	Schedule for Occupancy			Schedule for Lighting Receptacle			Schedule for HVAC System			Schedule for Service Hot Water			Schedule for Elevator			
	Percent of Maximum Load			Percent of Maximum Load						Percent of Maximum Load			Percent of Maximum Load			
	Wk	Sat	Sun	Wk	Sat	Sun	Wk	Sat	Sun	Wk	Sat	Sun	Wk	Sat	Sun	
1 (12-1am)	90	90	70	20	20	30	on	on	on	20	20	25	40	44	55	
2 (1-2am)	90	90	70	15	20	30	on	on	on	15	15	20	33	35	55	
3 (2-3am)	90	90	70	10	10	20	on	on	on	15	15	20	33	35	43	
4 (3-4am)	90	90	70	10	10	20	on	on	on	15	15	20	33	35	43	
5 (4-5am)	90	90	70	10	10	20	on	on	on	20	20	20	33	35	43	
6 (5-6am)	90	90	70	20	10	20	on	on	on	25	25	30	33	35	43	
7 (6-7am)	70	70	70	40	30	30	on	on	on	50	40	50	42	40	52	
8 (7-8am)	40	50	70	50	30	40	on	on	on	60	50	50	42	32	52	
9 (8-9am)	40	50	50	40	40	40	on	on	on	55	50	50	52	45	65	
10 (9-10am)	20	30	50	40	40	30	on	on	on	45	50	55	52	45	65	
11 (10-11am)	20	30	50	25	30	30	on	on	on	40	45	50	40	42	53	
12 (11-12pm)	20	30	30	25	25	30	on	on	on	45	50	50	51	60	60	
13 (12-1pm)	20	30	30	25	25	30	on	on	on	40	50	40	51	65	53	
14 (1-2pm)	20	30	20	25	25	20	on	on	on	35	45	40	51	65	51	
15 (2-3pm)	20	30	20	25	25	20	on	on	on	30	40	30	51	65	50	
16 (3-4pm)	30	30	20	25	25	20	on	on	on	30	40	30	51	65	44	
17 (4-5pm)	50	30	30	25	25	20	on	on	on	30	35	30	63	65	64	
18 (5-6pm)	50	50	40	25	25	20	on	on	on	40	40	40	80	75	62	
19 (6-7pm)	50	60	40	60	60	50	on	on	on	55	55	50	86	80	65	
20 (7-8pm)	70	60	60	80	70	70	on	on	on	60	55	50	70	80	63	
21 (8-9pm)	70	60	60	90	70	80	on	on	on	50	50	40	70	75	63	
22 (9-10pm)	80	70	80	80	70	60	on	on	on	55	55	50	70	75	63	
23 (10-11pm)	90	70	80	60	60	50	on	on	on	45	40	40	45	55	40	
24 (11-12am)	90	70	80	30	30	30	on	on	on	25	30	20	45	55	40	
Total/Day	1390	1390	1300	855	785	810	2400	2400	2400	915	930	900	1217	1303	1287	
Total/Week		96.40	hours		58.70	hours			168.0	hours		64.05	hours		86.75	hours
Total/Year		5026	hours		3061	hours			8760	hours		3340	hours		4523	hours

Wk = Weekday

- Schedules for occupancy, lighting, receptacle, HVAC system and service hot water are from ASHRAE Standard 90.1-1989 and addendums, except that 5% emergency lighting has been added for all off hours. Elevator schedules, except for restaurants, are from the U.S. Department of Energy Standard Evaluation Techniques except changed to 0% when occupancy is 0%. THESE VALUES MAY BE USED ONLY IF ACTUAL SCHEDULES ARE NOT KNOWN.

TABLE 3-2D
Light Manufacturing Occupancy¹

Hour of Day (time)	Schedule for Occupancy			Schedule for Lighting Receptacle			Schedule for HVAC System			Schedule for Service Hot Water			Schedule for Elevator		
	Percent of Maximum Load			Percent of Maximum Load						Percent of Maximum Load			Percent of Maximum Load		
	Wk	Sat	Sun	Wk	Sat	Sun	Wk	Sat	Sun	Wk	Sat	Sun	Wk	Sat	Sun
1 (12-1am)	0	0	0	5	5	5	off	off	off	5	5	4	0	0	0
2 (1-2am)	0	0	0	5	5	5	off	off	off	5	5	4	0	0	0
3 (2-3am)	0	0	0	5	5	5	off	off	off	5	5	4	0	0	0
4 (3-4am)	0	0	0	5	5	5	off	off	off	5	5	4	0	0	0
5 (4-5am)	0	0	0	5	5	5	off	off	off	5	5	4	0	0	0
6 (5-6am)	0	0	0	10	5	5	off	off	off	8	8	7	0	0	0
7 (6-7am)	10	10	5	10	10	5	on	on	off	7	7	4	0	0	0
8 (7-8am)	20	10	5	30	10	5	on	on	off	19	11	4	35	16	0
9 (8-9am)	95	30	5	90	30	5	on	on	off	35	15	4	69	14	0
10 (9-10am)	95	30	5	90	30	5	on	on	off	38	21	4	43	21	0
11 (10-11am)	95	30	5	90	30	5	on	on	off	39	19	4	37	18	0
12 (11-12pm)	95	30	5	90	30	5	on	on	off	47	23	6	43	25	0
13 (12-1pm)	50	10	5	80	15	5	on	on	off	57	20	6	58	21	0
14 (1-2pm)	95	10	5	90	15	5	on	on	off	54	19	9	48	13	0
15 (2-3pm)	95	10	5	90	15	5	on	on	off	34	15	6	37	8	0
16 (3-4pm)	95	10	5	90	15	5	on	on	off	33	12	4	37	4	0
17 (4-5pm)	95	10	5	90	15	5	on	on	off	44	14	4	46	5	0
18 (5-6pm)	30	5	5	50	5	5	on	on	off	26	7	4	62	6	0
19 (6-7pm)	10	5	0	30	5	5	on	off	off	21	7	4	20	0	0
20 (7-8pm)	10	0	0	30	5	5	on	off	off	15	7	4	12	0	0
21 (8-9pm)	10	0	0	20	5	5	on	off	off	17	7	4	4	0	0
22 (9-10pm)	10	0	0	20	5	5	on	off	off	8	9	7	4	0	0
23 (10-11pm)	5	0	0	10	5	5	off	off	off	5	5	4	0	0	0
24 (11-12am)	5	0	0	5	5	5	off	off	off	5	5	4	0	0	0
Total/Day	920	200	60	1040	280	120	1600	1200	0	537	256	113	555	151	0
Total/Week		48.60	hours		56.00	hours		92.00	hours		30.54	hours		29.26	hours
Total/Year		2534	hours		2920	hours		4797	hours		1592	hours		1526	hours

Wk = Weekday

- Schedules for occupancy, lighting, receptacle, HVAC system and service hot water are from ASHRAE Standard 90.1-1989 and addendums, except that 5% emergency lighting has been added for all off hours. Elevator schedules, except for restaurants, are from the U.S. Department of Energy Standard Evaluation Techniques except changed to 0% when occupancy is 0%. THESE VALUES MAY BE USED ONLY IF ACTUAL SCHEDULES ARE NOT KNOWN.

TABLE 3-2E
Office Occupancy¹

Hour of Day (time)	Schedule for Occupancy			Schedule for Lighting Receptacle			Schedule for HVAC System			Schedule for Service Hot Water			Schedule for Elevator		
	Percent of Maximum Load			Percent of Maximum Load						Percent of Maximum Load			Percent of Maximum Load		
	Wk	Sat	Sun	Wk	Sat	Sun	Wk	Sat	Sun	Wk	Sat	Sun	Wk	Sat	Sun
1 (12-1am)	0	0	0	5	5	5	off	off	off	5	5	4	0	0	0
2 (1-2am)	0	0	0	5	5	5	off	off	off	5	5	4	0	0	0
3 (2-3am)	0	0	0	5	5	5	off	off	off	5	5	4	0	0	0
4 (3-4am)	0	0	0	5	5	5	off	off	off	5	5	4	0	0	0
5 (4-5am)	0	0	0	5	5	5	off	off	off	5	5	4	0	0	0
6 (5-6am)	0	0	0	10	5	5	off	off	off	8	8	7	0	0	0
7 (6-7am)	10	10	5	10	10	5	on	on	off	7	7	4	0	0	0
8 (7-8am)	20	10	5	30	10	5	on	on	off	19	11	4	35	16	0
9 (8-9am)	95	30	5	90	30	5	on	on	off	35	15	4	69	14	0
10 (9-10am)	95	30	5	90	30	5	on	on	off	38	21	4	43	21	0
11 (10-11am)	95	30	5	90	30	5	on	on	off	39	19	4	37	18	0
12 (11-12pm)	95	30	5	90	30	5	on	on	off	47	23	6	43	25	0
13 (12-1pm)	50	10	5	80	15	5	on	on	off	57	20	6	58	21	0
14 (1-2pm)	95	10	5	90	15	5	on	on	off	54	19	9	48	13	0
15 (2-3pm)	95	10	5	90	15	5	on	on	off	34	15	6	37	8	0
16 (3-4pm)	95	10	5	90	15	5	on	on	off	33	12	4	37	4	0
17 (4-5pm)	95	10	5	90	15	5	on	on	off	44	14	4	46	5	0
18 (5-6pm)	30	5	5	50	5	5	on	on	off	26	7	4	62	6	0
19 (6-7pm)	10	5	0	30	5	5	on	off	off	21	7	4	20	0	0

Hour of Day (time)	Schedule for Occupancy			Schedule for Lighting Receptacle			Schedule for HVAC System			Schedule for Service Hot Water			Schedule for Elevator		
	Percent of Maximum Load			Percent of Maximum Load						Percent of Maximum Load			Percent of Maximum Load		
	Wk	Sat	Sun	Wk	Sat	Sun	Wk	Sat	Sun	Wk	Sat	Sun	Wk	Sat	Sun
20 (7-8pm)	10	0	0	30	5	5	on	off	off	15	7	4	12	0	0
21 (8-9pm)	10	0	0	20	5	5	on	off	off	17	7	4	4	0	0
22 (9-10pm)	10	0	0	20	5	5	on	off	off	8	9	7	4	0	0
23 (10-11pm)	5	0	0	10	5	5	off	off	off	5	5	4	0	0	0
24 (11-12am)	5	0	0	5	5	5	off	off	off	5	5	4	0	0	0
Total/Day	920	200	60	1040	280	120	1600	1200	0	537	256	113	555	151	0
Total/Week		48.60	hours		56.00	hours		92.00	hours		30.54	hours		29.26	hours
Total/Year		2534	hours		2920	hours		4797	hours		1592	hours		1526	hours

Wk = Weekday

- Schedules for occupancy, lighting, receptacle, HVAC system and service hot water are from ASHRAE Standard 90.1-1989 and addendums, except that 5% emergency lighting has been added for all off hours. Elevator schedules, except for restaurants, are from the U.S. Department of Energy Standard Evaluation Techniques except changed to 0% when occupancy is 0%. THESE VALUES MAY BE USED ONLY IF ACTUAL SCHEDULES ARE NOT KNOWN.

TABLE 3-2F
Parking Garage Occupancy¹

Hour of Day (time)	Schedule for Occupancy			Schedule for Lighting Receptacle			Schedule for HVAC System			Schedule for Service Hot Water			Schedule for Elevator		
	Percent of Maximum Load			Percent of Maximum Load						Percent of Maximum Load			Percent of Maximum Load		
	Wk	Sat	Sun	Wk	Sat	Sun	Wk	Sat	Sun	Wk	Sat	Sun	Wk	Sat	Sun
1 (12-1am)				100	100	100									
2 (1-2am)				100	100	100									
3 (2-3am)				100	100	100									
4 (3-4am)				100	100	100									
5 (4-5am)				100	100	100									
6 (5-6am)				100	100	100									
7 (6-7am)				100	100	100									
8 (7-8am)				100	100	100									
9 (8-9am)				100	100	100									
10 (9-10am)				100	100	100									
11 (10-11am)				100	100	100									
12 (11-12pm)		N/A		100	100	100									
13 (12-1pm)				100	100	100									
14 (1-2pm)				100	100	100									
15 (2-3pm)				100	100	100									
16 (3-4pm)				100	100	100									
17 (4-5pm)				100	100	100									
18 (5-6pm)				100	100	100									
19 (6-7pm)				100	100	100									
20 (7-8pm)				100	100	100									
21 (8-9pm)				100	100	100									
22 (9-10pm)				100	100	100									
23 (10-11pm)				100	100	100									
24 (11-12am)				100	100	100									
Total/Day				2400	2400	2400									
Total/Week					168	hours									
Total/Year					8760	hours									

Wk = Weekday

- Schedules for occupancy, lighting, receptacle, HVAC system and service hot water are from ASHRAE Standard 90.1-1989 and addendums, except that 5% emergency lighting has been added for all off hours. Elevator schedules, except for restaurants, are from the U.S. Department of Energy Standard Evaluation Techniques except changed to 0% when occupancy is 0%. THESE VALUES MAY BE USED ONLY IF ACTUAL SCHEDULES ARE NOT KNOWN.

TABLE 3-2G
Restaurant Occupancy¹

Hour of Day (time)	Schedule for Occupancy			Schedule for Lighting Receptacle			Schedule for HVAC System			Schedule for Service Hot Water			Schedule for Elevator		
	Percent of Maximum Load			Percent of Maximum Load						Percent of Maximum Load			Percent of Maximum Load		
	Wk	Sat	Sun	Wk	Sat	Sun	Wk	Sat	Sun	Wk	Sat	Sun	Wk	Sat	Sun
1 (12-1am)	15	30	20	15	20	20	on	on	on	20	20	25	0	0	0
2 (1-2am)	15	25	20	15	15	15	on	on	on	15	15	20	0	0	0
3 (2-3am)	5	5	5	15	15	15	on	on	on	15	15	20	0	0	0
4 (3-4am)	0	0	0	15	15	15	off	off	off	0	0	0	0	0	0
5 (4-5am)	0	0	0	15	15	15	off	off	off	0	0	0	0	0	0
6 (5-6am)	0	0	0	20	15	15	off	off	off	0	0	0	0	0	0
7 (6-7am)	0	0	0	40	30	30	off	off	off	0	0	0	0	0	0
8 (7-8am)	5	0	0	40	30	30	on	off	off	60	0	0	0	0	0
9 (8-9am)	5	0	0	60	60	50	on	off	off	55	0	0	0	0	0
10 (9-10am)	5	5	0	60	60	50	on	on	off	45	50	0	0	0	0
11 (10-11am)	20	20	10	90	80	70	on	on	on	40	45	50	0	0	0
12 (11-12pm)	50	45	20	90	80	70	on	on	on	45	50	50	0	0	0
13 (12-1pm)	80	50	25	90	80	70	on	on	on	40	50	40	0	0	0
14 (1-2pm)	70	50	25	90	80	70	on	on	on	35	45	40	0	0	0
15 (2-3pm)	40	35	15	90	80	70	on	on	on	30	40	30	0	0	0
16 (3-4pm)	20	30	20	90	80	70	on	on	on	30	40	30	0	0	0
17 (4-5pm)	25	30	25	90	80	60	on	on	on	30	35	30	0	0	0
18 (5-6pm)	50	30	35	90	90	60	on	on	on	40	40	40	0	0	0
19 (6-7pm)	80	70	55	90	90	60	on	on	on	55	55	50	0	0	0
20 (7-8pm)	80	90	65	90	90	60	on	on	on	60	55	50	0	0	0
21 (8-9pm)	80	70	70	90	90	60	on	on	on	50	50	40	0	0	0
22 (9-10pm)	50	65	35	90	90	60	on	on	on	55	55	50	0	0	0
23 (10-11pm)	35	55	20	50	50	50	on	on	on	45	40	40	0	0	0
24 (11-12am)	20	35	20	30	30	30	on	on	on	25	30	20	0	0	0
Total/Day	750	740	485	1455	1365	1115	2000	1800	1700	790	730	625	0	0	0
Total/Week		49.75	hours		97.55	hours		135	hours		53.05	hours		0	hours
Total/Year		2594	hours		5086	hours		7039	hours		2766	hours		0	hours

Wk = Weekday

- Schedules for occupancy, lighting, receptacle, HVAC system and service hot water are from ASHRAE Standard 90.1-1989 and addendums, except that 5% emergency lighting has been added for all off hours. Elevator schedules, except for restaurants, are from the U.S. Department of Energy Standard Evaluation Techniques except changed to 0% when occupancy is 0%. THESE VALUES MAY BE USED ONLY IF ACTUAL SCHEDULES ARE NOT KNOWN.

TABLE 3-2H
Retail Occupancy¹

Hour of Day (time)	Schedule for Occupancy			Schedule for Lighting Receptacle			Schedule for HVAC System			Schedule for Service Hot Water			Schedule for Elevator		
	Percent of Maximum Load			Percent of Maximum Load						Percent of Maximum Load			Percent of Maximum Load		
	Wk	Sat	Sun	Wk	Sat	Sun	Wk	Sat	Sun	Wk	Sat	Sun	Wk	Sat	Sun
1 (12-1am)	0	0	0	5	5	5	off	off	off	4	11	7	0	0	0
2 (1-2am)	0	0	0	5	5	5	off	off	off	5	10	7	0	0	0
3 (2-3am)	0	0	0	5	5	5	off	off	off	5	8	7	0	0	0
4 (3-4am)	0	0	0	5	5	5	off	off	off	4	6	6	0	0	0
5 (4-5am)	0	0	0	5	5	5	off	off	off	4	6	6	0	0	0
6 (5-6am)	0	0	0	5	5	5	off	off	off	4	6	6	0	0	0
7 (6-7am)	0	0	0	5	5	5	on	on	off	4	7	7	0	0	0
8 (7-8am)	10	10	0	20	10	5	on	on	off	15	20	10	12	9	0
9 (8-9am)	20	20	0	50	30	10	on	on	on	23	24	12	22	21	0
10 (9-10am)	50	50	10	90	60	10	on	on	on	32	27	14	64	56	11
11 (10-11am)	50	60	20	90	90	40	on	on	on	41	42	29	74	66	13
12 (11-12pm)	70	80	20	90	90	40	on	on	on	57	54	31	68	68	35
13 (12-1pm)	70	80	40	90	90	60	on	on	on	62	59	36	68	68	37
14 (1-2pm)	70	80	40	90	90	60	on	on	on	61	60	36	71	69	37
15 (2-3pm)	70	80	40	90	90	60	on	on	on	50	49	34	72	70	39
16 (3-4pm)	80	80	40	90	90	60	on	on	on	45	48	35	72	69	41
17 (4-5pm)	70	80	40	90	90	60	on	on	on	46	47	37	73	66	38
18 (5-6pm)	50	60	20	90	90	40	on	on	off	47	46	34	68	58	34
19 (6-7pm)	50	20	10	60	50	20	on	on	off	42	44	25	68	47	3

Hour of Day	Schedule for Occupancy			Schedule for Lighting Receptacle			Schedule for HVAC System			Schedule for Service Hot Water			Schedule for Elevator		
	Percent of Maximum Load			Percent of Maximum Load						Percent of Maximum Load			Percent of Maximum Load		
20 (7-8pm)	30	20	0	60	30	5	on	on	off	34	36	27	58	43	0
21 (8-9pm)	30	20	0	50	30	5	on	on	off	33	29	21	54	43	0
22 (9-10pm)	0	10	0	20	10	5	off	on	off	23	22	16	0	8	0
23 (10-11pm)	0	0	0	5	5	5	off	off	off	13	16	10	0	0	0
24 (11-12am)	0	0	0	5	5	5	off	off	off	8	13	6	0	0	0
Total/Day	720	750	280	1115	985	525	1500	1600	900	662	690	459	844	761	288
Total/Week	46.30 hours			70.85 hours			100 hours			44.59 hours			52.69 hours		
Total/Year	2414 hours			3694 hours			5214 hours			2325 hours			2747 hours		

Wk = Weekday

- Schedules for occupancy, lighting, receptacle, HVAC system and service hot water are from ASHRAE Standard 90.1-1989 and addendums, except that 5% emergency lighting has been added for all off hours. Elevator schedules, except for restaurants, are from the U.S. Department of Energy Standard Evaluation Techniques except changed to 0% when occupancy is 0%. THESE VALUES MAY BE USED ONLY IF ACTUAL SCHEDULES ARE NOT KNOWN.

TABLE 3-2I
School Occupancy¹

Hour of Day (time)	Schedule for Occupancy			Schedule for Lighting Receptacle			Schedule for HVAC System			Schedule for Service Hot Water			Schedule for Elevator		
	Percent of Maximum Load			Percent of Maximum Load						Percent of Maximum Load			Percent of Maximum Load		
	Wk	Sat	Sun	Wk	Sat	Sun	Wk	Sat	Sun	Wk	Sat	Sun	Wk	Sat	Sun
1 (12-1am)	0	0	0	5	5	5	off	off	off	5	3	3	0	0	0
2 (1-2am)	0	0	0	5	5	5	off	off	off	5	3	3	0	0	0
3 (2-3am)	0	0	0	5	5	5	off	off	off	5	3	3	0	0	0
4 (3-4am)	0	0	0	5	5	5	off	off	off	5	3	3	0	0	0
5 (4-5am)	0	0	0	5	5	5	off	off	off	5	3	3	0	0	0
6 (5-6am)	0	0	0	5	5	5	off	off	off	5	3	3	0	0	0
7 (6-7am)	0	0	0	5	5	5	off	off	off	5	3	3	0	0	0
8 (7-8am)	5	0	0	30	5	5	on	off	off	10	3	3	0	0	0
9 (8-9am)	75	10	0	85	15	5	on	on	off	34	3	5	30	0	0
10 (9-10am)	90	10	0	95	15	5	on	on	off	60	5	5	30	0	0
11 (10-11am)	90	10	0	95	15	5	on	on	off	63	5	5	30	0	0
12 (11-12pm)	80	10	0	95	15	5	on	on	off	72	5	5	30	0	0
13 (12-1pm)	80	10	0	80	15	5	on	on	off	79	5	5	30	0	0
14 (1-2pm)	80	0	0	80	5	5	on	off	off	83	3	5	30	0	0
15 (2-3pm)	80	0	0	80	5	5	on	off	off	61	3	3	30	0	0
16 (3-4pm)	45	0	0	70	5	5	on	off	off	65	3	3	15	0	0
17 (4-5pm)	15	0	0	50	5	5	on	off	off	10	3	3	0	0	0
18 (5-6pm)	5	0	0	50	5	5	on	off	off	10	3	3	0	0	0
19 (6-7pm)	15	0	0	35	5	5	on	off	off	19	3	3	0	0	0
20 (7-8pm)	20	0	0	35	5	5	on	off	off	25	3	3	0	0	0
21 (8-9pm)	20	0	0	35	5	5	on	off	off	22	3	3	0	0	0
22 (9-10pm)	10	0	0	30	5	5	on	off	off	22	3	3	0	0	0
23 (10-11pm)	0	0	0	5	5	5	off	off	off	12	3	3	0	0	0
24 (11-12am)	0	0	0	5	5	5	off	off	off	9	3	3	0	0	0
Total/Day	710	50	0	990	170	120	1500	500	0	691	80	84	285	0	0
Total/Week	36.00 hours			52.40 hours			80.00 hours			36.19 hours			14.25 hours		
Total/Year	1877 hours			2732 hours			4171 hours			1887 hours			743 hours		

Wk = Weekday

- Schedules for occupancy, lighting, receptacle, HVAC system and service hot water are from ASHRAE Standard 90.1-1989 and addendums, except that 5% emergency lighting has been added for all off hours. Elevator schedules, except for restaurants, are from the U.S. Department of Energy Standard Evaluation Techniques except changed to 0% when occupancy is 0%. THESE VALUES MAY BE USED ONLY IF ACTUAL SCHEDULES ARE NOT KNOWN.

TABLE 3-2J
Warehouse Occupancy¹

Hour of Day (time)	Schedule for Occupancy			Schedule for Lighting Receptacle			Schedule for HVAC System			Schedule for Service Hot Water			Schedule for Elevator		
	Percent of Maximum Load			Percent of Maximum Load						Percent of Maximum Load			Percent of Maximum Load		
	Wk	Sat	Sun	Wk	Sat	Sun	Wk	Sat	Sun	Wk	Sat	Sun	Wk	Sat	Sun
1 (12-1am)	0	0	0	5	5	5	off	off	off	2	2	2	0	0	0
2 (1-2am)	0	0	0	5	5	5	off	off	off	2	2	2	0	0	0
3 (2-3am)	0	0	0	5	5	5	off	off	off	2	2	2	0	0	0
4 (3-4am)	0	0	0	5	5	5	off	off	off	2	2	2	0	0	0
5 (4-5am)	0	0	0	5	5	5	off	off	off	5	2	2	0	0	0
6 (5-6am)	0	0	0	5	5	5	off	off	off	7	2	2	0	0	0
7 (6-7am)	0	0	0	5	5	5	off	off	off	7	2	2	0	0	0
8 (7-8am)	15	0	0	40	5	5	on	off	off	10	2	2	0	0	0
9 (8-9am)	70	20	0	70	8	5	on	on	off	30	6	2	0	0	0
10 (9-10am)	90	20	0	90	24	5	on	on	off	36	12	2	0	0	0
11 (10-11am)	90	20	0	90	24	5	on	on	off	36	12	2	30	0	0
12 (11-12pm)	90	20	0	90	24	5	on	on	off	46	17	2	0	0	0
13 (12-1pm)	50	10	0	80	5	5	on	on	off	57	4	4	0	0	0
14 (1-2pm)	85	10	0	90	5	5	on	on	off	43	4	4	0	0	0
15 (2-3pm)	85	10	0	90	5	5	on	on	off	38	2	2	0	0	0
16 (3-4pm)	85	10	0	90	5	5	on	on	off	40	2	2	40	0	0
17 (4-5pm)	20	0	0	90	5	5	on	off	off	30	2	2	0	0	0
18 (5-6pm)	0	0	0	30	5	5	off	off	off	18	2	2	0	0	0
19 (6-7pm)	0	0	0	5	5	5	off	off	off	3	2	2	0	0	0
20 (7-8pm)	0	0	0	5	5	5	off	off	off	3	2	2	0	0	0
21 (8-9pm)	0	0	0	5	5	5	off	off	off	3	2	2	0	0	0
22 (9-10pm)	0	0	0	5	5	5	off	off	off	3	2	2	0	0	0
23 (10-11pm)	0	0	0	5	5	5	off	off	off	3	2	2	0	0	0
24 (11-12am)	0	0	0	5	5	5	off	off	off	3	2	2	0	0	0
Total/Day	680	120	0	915	180	120	1000	800	0	429	91	52	70	0	0
Total/Week		35.20	hours		48.75	hours		58.00	hours		22.88	hours		3.50	hours
Total/Year		1835	hours		2542	hours		3024	hours		1193	hours		182	hours

Wk = Weekday

1. Schedules for occupancy, lighting, receptacle, HVAC system and service hot water are from ASHRAE Standard 90.1-1989 and addendums, except that 5% emergency lighting has been added for all off hours. Elevator schedules, except for restaurants, are from the U.S. Department of Energy Standard Evaluation Techniques except changed to 0% when occupancy is 0%. THESE VALUES MAY BE USED ONLY IF ACTUAL SCHEDULES ARE NOT KNOWN.

TABLE 3-3
HVAC Systems of Prototype Buildings³

Use	System #	Remarks
1. Assembly		
a. Churches (any size)	1	
b. ≤ 50,000 ft ² or ≤ 3 floors	1 or 3	Note 2
c. > 50,000 ft ² or > 3 floors	3	
2. Health		
a. Nursing Home (any size)	2	
b. ≤ 15,000 ft ²	1	
c. > 15,000 ft ² and ≤ 50,000 ft ²	4	Note 3
d. > 50,000 ft ²	5	Note 3,4
3. Hotel/Motel		
a. ≤ 3 Stories	2	Note 6
b. > 3 Stories	6	Note 7
4. Light Manufacturing	1 or 3	
5. Office		
a. ≤ 20,000 ft ²	1	
b. > 20,000 ft ² and either ≤ 3 floors or ≤ 75,000 ft ²	4	
c. > 75,000 ft ² or > 3 floors	5	
6. Restaurant	1 or 3	Note 2
7. Retail		
a. ≤ 50,000 ft ²	1 or 3	Note 2
b. > 50,000 ft ²	4 or 5	Note 2
8. Schools		
a. ≤ 75,000 ft ² or ≤ 3 floors	1	
b. > 75,000 ft ² or > 3 floors	3	
9. Warehouse		Note 5

Footnote to TABLE 3-3: The system and energy types presented in this table are not intended as requirements or recommendations for the proposed design. Floors areas in the table are the total conditioned floor areas for the listed use in the building. The number of floors indicated in the table is the total number of occupied floors for the listed use.

TABLE 3-3 (cont.)
HVAC System Descriptions for Prototype Buildings¹

HVAC Component	System #1	System #2
System Description	Packaged rooftop single zone, one unit per zone.	Packaged terminal air conditioner with space heater or heat pump, heating or cooling unit per zone.
Fan System		
Design Supply Circulation Rate	Note 10	Note 11
Supply Fan Control	Constant volume.	Fan cycles with call for heating or cooling.
Return Fan Control	N.A.	N.A.
Cooling System	Direct expansion air cooled	Direct expansion air cooled.
Heating System	Furnace, heat pump, or electric resistance.	Heat pump with electric resistance auxiliary or air conditioner with space heater.
Remarks	Drybulb economizer per Section 1433, heat recovery if required by Section 1436.	No economizer, if not required by Section 1433.

**TABLE 3-3 (cont.)
HVAC Systems Descriptions for Prototype Buildings¹**

HVAC Component	System #3	System #4
System Description	Air handler per zone with central plant.	Packaged rooftop VAV with perimeter reheat and fan-powered terminal units.
Fan System Design Supply Circulation Rate	Note 10	Note 10
Supply Fan Control	Constant volume.	VAV with forward curved centrifugal fan and variable inlet fans.
Return Fan Control	Constant volume.	VAV with forward curved centrifugal fan and discharge dampers.
Cooling System	Chilled water (Note 12)	Direct expansion air cooled.
Heating System	Hot water (Note 13)	Hot water (Note 13) or electric resistance.
Remarks	Drybulb economizer per Section 1433, heat recovery if required by Section 1436.	Drybulb economizer per Section 1433. Minimum VAV setting per Section 1435 Exception 1, Supply air reset by zone of greatest cooling demand, heat recovery if required by Section 1436.

**TABLE 3-3 (cont.)
HVAC System Descriptions for Prototype Buildings¹**

HVAC Component	System #5	System #6
System Description	Built-up central VAV with perimeter reheat and fan-powered terminal units	Four-pipe fan coil per zone with central plant.
Fan System Design Supply Circulation Rate	Note 10	Note 10
Supply Fan Control	VAV with air-foil centrifugal fan and AC frequency variable speed drive.	Fan cycles with call for heating or cooling.
Return Fan Control	VAV with air-foil centrifugal fan and AC frequency variable speed drive.	NA
Cooling System	Chilled water (Note 12)	Chilled water (Note 12)
Heating System	Hot water (Note 13) or electric resistance.	Hot water (Note 13) or electric resistance.
Remarks	Drybulb economizer per Section 1433. Minimum VAV setting per Section 1435 Exception 1, Supply air rest by zone of greatest cooling demand, heat recovery if required by Section 1436.	No economizer, if not required by Section 1433.

**Numbered Footnotes for TABLE 3-3
HVAC System Descriptions for Prototype Buildings**

1. The systems and energy types presented in this Table are not intended as requirements or recommendations for the proposed design.
2. For occupancies such as restaurants, assembly and retail that are part of a mixed use building which,

3. Constant volume may be used in zones where pressurization relationships must be maintained by code. Where constant volume is used, the system shall have heat recovery if required by Section 1436. VAV shall be used in all other areas, in accordance with Sections 1432 through 1439.
4. Provide run-around heat recovery systems for all fan systems with a minimum outside air intake greater than 70%. Recovery effectiveness shall be 0.50.
5. If a warehouse is not intended to be mechanically cooled, both the standard and proposed designs shall be calculated assuming no mechanical cooling.
6. The system listed is for guest rooms only. Areas such as public areas and back-of-house areas shall be served by system 4. Other areas such as offices and retail shall be served by systems listed in Table 3-3 for these occupancy types.
7. The system listed is for guest rooms only. Areas such as public areas and back-of-house areas shall be served by system 5. Other areas such as offices and retail shall be served by systems listed in Table 3-3 for these occupancy types.
8. Reserved.
9. Reserved.
10. Design supply air circulation rate shall be based on a supply-air-to-room air temperature difference of 20°F. A higher supply air temperature may be used if required to maintain a minimum circulation rate of 4.5 air changes per hour or 15 cfm per person to each zone served by the system, at design conditions. If return fans are specified, they shall be sized for the supply fan capacity less the required minimum ventilation with outside air, or 75% of the supply fan capacity, whichever is larger. Except where noted, supply and return fans shall be operated continuously during occupied hours.
11. Fan energy when included in the efficiency rating of the unit as defined in Section 1411, need not be modeled explicitly for this system. The fan shall cycle with calls for heating or cooling.
12. Chilled water systems shall be modeled using a reciprocating chiller for systems with total cooling capacities less than 175 tons, and centrifugal chillers for systems with cooling capacities of 175 tons or greater. For systems with cooling capacities of 600 tons or more, the standard design energy consumption shall be calculated using two centrifugal chillers, lead/lag controlled. Chilled water shall be assumed to be controlled at a constant 44°F. Chiller water pumps shall be sized using a 12°F temperature rise, from 44°F to 56°F, operating at 65% combined impeller and motor efficiency. Condenser water pumps shall be sized using a 10°F temperature rise, operating at 60% combined impeller and motor efficiency. The cooling tower shall be an open circuit, centrifugal blower type sized for the larger of 85°F leaving water temperature or 10°F approach to design wetbulb temperature. The tower shall be controlled to provide a 65°F leaving water temperature whenever weather conditions permit, floating up to design leaving water temperatures at design conditions. Chilled water supply temperature shall be reset in accordance with Section 1432.2.2.
13. Hot water system shall include a natural draft fossil fuel or electric boiler. The hot water pump shall be sized

based on a 30°F temperature drop, from 180°F to 150°F, operating at a combined impeller and motor efficiency of 60%. Hot water supply temperature shall be reset in accordance with Section 1432.2.2.

[Statutory Authority: RCW 19.27A.025, 19.27A.045, 01-03-010, § 51-11-99903, filed 1/5/01, effective 7/1/01; 98-03-003, § 51-11-99903, filed 1/8/98, effective 7/1/98. Statutory Authority: RCW 19.27A.025, 93-21-052, § 51-11-99903, filed 10/18/93, effective 4/1/94.]

WAC 51-11-99904 Section 4—Suggested software for systems analysis approach.

Program Name	Source
Blast 3.0 (Level 334)	Blast Support Office University of Illinois Dept. of Mechanical and Industrial Engineering 1206 W. Green Street, Room 140, MEB Urbana, IL 61801 (217) 244-8182
DOE 2.1E	Energy Science and Technology Software Center (ESTSC) PO Box 1220 Oakridge, TN 37831-1020 423-576-2606
DOE 2.1E or DOE 2.2	James J. Hirsch & Associates Building Performance Analysis Software & Consulting 12185 Presilla Road Camarillo, CA 93012-9243 (805) 532-1045
EnergyPlus	Kathy Ellington Lawrence Berkeley National Laboratory (LBNL) Building 90, Room 3147 Berkeley, CA 94720-0001 (510) 486-5711
ESAS	Ross Meriweather Consulting, Engineering 3315 Outrider San Antonio, TX 78247-4405 210-490-7081
ESP-II	Automated Procedures for Engineering Consultants, Inc. 40 W. 4th Centre, Suite 2100 Dayton, OH 45402 937-228-2602
HAP 3.24	Carrier Building Systems and Services 3215 South 116th St., Suite 133 Tukwila, WA 98168 (206)-439-0097
Trace 600 Version 18.11 or Trace 700	The Trane Co. 3600 Pammel Creek Rd. Lacrosse, WI 54601 608-787-3926

[Statutory Authority: RCW 19.27A.025, 19.27A.045, 01-03-010, § 51-11-99904, filed 1/5/01, effective 7/1/01; 98-03-003, § 51-11-99904, filed (2003 Ed.)

1/8/98, effective 7/1/98. Statutory Authority: RCW 19.27A.025, 93-21-052, § 51-11-99904, filed 10/18/93, effective 4/1/94.]

**Chapter 51-13 WAC
VENTILATION AND INDOOR AIR QUALITY**

WAC

51-13-100	Chapter 1—Administration and enforcement.
51-13-101	Scope and general requirements.
51-13-102	Alternate systems and materials method of design, construction and installation.
51-13-103	Plans and specifications.
51-13-104	Enforcement and inspections.
51-13-105	Validity.
51-13-106	Conflicts with other codes.
51-13-107	Violations.
51-13-108	Liability.
51-13-200	Definitions.
51-13-201	General.
51-13-202	Definitions.
51-13-300	Chapter 3—Ventilation systems.
51-13-301	Compliance with this chapter.
51-13-302	Mechanical ventilation criteria using performance or design methods for Group R Occupancies four stories and less.
51-13-303	Mechanical ventilation criteria using prescriptive methods for Group R Occupancies four stories and less.
51-13-304	Mechanical ventilation criteria and minimum ventilation performance for all other occupancies not covered in sections 302 and 303.
51-13-400	Chapter 4—Indoor air quality.
51-13-401	Pollutant source control.
51-13-402	Solid fuel burning appliances and fireplaces.
51-13-500	Chapter 5—Radon resistive construction standards.
51-13-501	Scope.
51-13-502	Statewide radon requirements.
51-13-503	Radon prescriptive requirements.

WAC 51-13-100 Chapter 1—Administration and enforcement.

[Statutory Authority: RCW 19.27.190, 91-01-102, § 51-13-100, filed 12/18/90, effective 7/1/91.]

WAC 51-13-101 Scope and general requirements.

101.1 Title: This Code shall be known as the Washington State Ventilation and Indoor Air Quality Code. It is herein referred to as "this Code".

101.2 Intent: The purpose of this Code is to provide minimum standards for the design and installation of mechanical ventilation systems, the selection of structural materials used within the conditioned space, and the construction of radon mitigation systems for new construction.

It is intended that these provisions provide flexibility to permit the use of innovative approaches and techniques. These provisions are structured to permit compliance with the intent of this Code by demonstration of performance through on site testing or through engineered design. This Code is not intended to abridge any safety or health requirements required under any other applicable codes or ordinances.

101.3 Scope: This Code sets forth minimum requirements for ventilation in all occupancies, including the design of new construction.

101.3.1 Application to Existing Buildings

101.3.1.1 Additions to Existing Buildings: Additions to existing buildings or structures may be made without making the entire building comply, provided that the new addition shall conform to the provisions of this Code.

EXCEPTIONS

1. Additions with less than 500 square feet of conditioned floor area are exempt from the requirements in this code for Whole House Ventilation Systems, Section 302.2.2.
2. Additions or alterations to existing buildings which do not require the construction of foundations, crawl-spaces, slabs, or basements shall not be required to meet the requirements for radon protection.

101.3.1.2 Alterations and Repairs: All alterations and repairs may be made to existing or moved buildings built or permitted prior to the enforcement of this Code without making the entire building comply with the provisions of this Code, provided the alterations or repairs comply with this Code.

EXCEPTION:

Air handling/conditioning equipment, which is being replaced without alteration or repair of the associated air distribution system is exempt from the requirements of this Code.

101.3.1.3 Historic Buildings: Historic buildings are exempt from this Code only to the extent necessary to preserve those features essential to their historical appearance or function.

101.4 Operating Instructions: Installers shall provide the manufacturer's installation, operating instructions, and a whole house ventilation system operation description.

[Statutory Authority: RCW 19.27.190, 19.27.020, 01-02-099, § 51-13-101, filed 1/3/01, effective 7/1/01. Statutory Authority: RCW 19.27.190(2) and 1992 c 132, 93-02-056, § 51-13-101, filed 1/6/93, effective 7/1/93. Statutory Authority: RCW 19.27.190, 91-01-102, § 51-13-101, filed 12/18/90, effective 7/1/91.]

WAC 51-13-102 Alternate systems and materials method of design, construction and installation.

102.1 Alternate Materials and Methods of Construction: The provisions of this Code are not intended to prevent the use of any material, method of construction, design or ventilation system not specifically prescribed herein, provided that such construction, design, or ventilation system has been approved by the building official.

The building official may approve any such alternate, provided that the proposed design is satisfactory and complies with the provisions of this Code and that the material, method, or work offered is, for the purpose intended, at least the equivalent of that prescribed in this Code in suitability, effectiveness, safety, and indoor air quality.

The building official may require plans and specifications to be submitted in support of an application for a building permit. Plans and specifications may be required by the building official to be stamped and authenticated by an engineer or architect licensed by the state to practice as such.

[Statutory Authority: RCW 19.27.190, 91-01-102, § 51-13-102, filed 12/18/90, effective 7/1/91.]

[Title 51 WAC—p. 110]

WAC 51-13-103 Plans and specifications.

103.1 General: With each application for a building permit, and when required by the building official, plans and specifications demonstrating compliance with this Code shall be submitted. The building official may require that plans and specifications be stamped and authenticated by an engineer, architect, or other qualified professional licensed to practice in the state.

103.2 Details: The plans and specifications shall show in sufficient detail pertinent data and features of the materials, equipment and systems as herein governed, including, but not limited to: design criteria, structural panel materials, size and type of apparatus and equipment, systems and equipment controls, provisions for combustion air to fuel burning appliances, and other pertinent data to indicate conformance with the requirements of this Code.

[Statutory Authority: RCW 19.27.190, 91-01-102, § 51-13-103, filed 12/18/90, effective 7/1/91.]

WAC 51-13-104 Enforcement and inspections.

104.1 General: Pertinent data and features of the building and the materials, equipment and/or systems as herein governed shall be subject to inspection by the building official.

104.2 Approvals Required: No materials, equipment, systems, or portions thereof, shall be concealed without first obtaining approval from the building official.

104.3 Tests: Whenever there is insufficient evidence of compliance with any of the provisions in this Code or evidence that any material or construction does not conform to the requirements of this Code, the building official may require tests as proof of compliance to be made at no expense to the local jurisdiction.

Test methods shall be as specified by this Code or by other recognized test standards. If there are no recognized or accepted test methods for the proposed alternate, the building official shall determine test procedures.

104.4 Final Inspection: All materials, equipment, and systems herein governed shall be inspected and approved before the building shall be deemed ready for occupancy.

[Statutory Authority: RCW 19.27.190, 91-01-102, § 51-13-104, filed 12/18/90, effective 7/1/91.]

WAC 51-13-105 Validity.

105.1 Validity: If a section, subsection, sentence, clause, or phrase of this Code is, for any reason, held to be unconstitutional, such decision shall not affect the validity of the remaining portion of this Code.

[Statutory Authority: RCW 19.27.190, 91-01-102, § 51-13-105, filed 12/18/90, effective 7/1/91.]

WAC 51-13-106 Conflicts with other codes.

106.1 Conflicts with Other Codes: In addition to the requirements of this Code, buildings must conform to the provisions of the State Building Code (chapter 19.27 RCW

and chapters 51-40, 51-42, 51-44 and 51-46 Washington Administrative Code). In case of conflicts between the Uniform Building, Uniform Plumbing, Uniform Mechanical, and Uniform Fire Codes as adopted and amended in chapters 51-40, 51-42, 51-44 and 51-46 Washington Administrative Code, the provisions of chapter 51-13 shall govern. This Code is not intended to abridge any safety or health requirements under any other applicable codes or ordinances.

Where, in any specific case, different sections of this Code specify different materials, methods of construction or other requirements, the most restrictive shall govern. Where there is a conflict between a general requirement and a specific requirement, the specific requirement shall be applicable.

Wherever in this Code reference is made to the appendix, the provisions of the appendix shall not apply unless specifically adopted.

106.2 Authority: Local legislative authorities are authorized and directed to enforce this Code. Local legislative authorities are authorized to promulgate, adopt, and issue those rules and regulations necessary for the effective and efficient administration of this Code.

[Statutory Authority: RCW 19.27.190 and 19.27.020. 98-02-047, § 51-13-106, filed 1/5/98, effective 7/1/98. Statutory Authority: RCW 19.27.190. 95-01-128, § 51-13-106, filed 12/21/94, effective 6/30/95; 91-01-102, § 51-13-106, filed 12/18/90, effective 7/1/91.]

WAC 51-13-107 Violations.

107.1 Violations: It shall be unlawful for any persons, firm, or corporation to erect or construct any building, or remodel or rehabilitate any existing building or structure in the state, or allow the same to be done in violation of any of the provisions of this Code.

[Statutory Authority: RCW 19.27.190. 91-01-102, § 51-13-107, filed 12/18/90, effective 7/1/91.]

WAC 51-13-108 Liability.

108.1 Liability: Nothing contained in this Code is intended to be nor shall be construed to create nor form the basis for any liability on the part of any city or county or its officers, employees, or agents for any injury or damage resulting from the failure of a building to conform to the provisions of this Code.

[Statutory Authority: RCW 19.27.190. 91-01-102, § 51-13-108, filed 12/18/90, effective 7/1/91.]

WAC 51-13-200 Definitions.

[Statutory Authority: RCW 19.27.190. 91-01-102, § 51-13-200, filed 12/18/90, effective 7/1/91.]

WAC 51-13-201 General.

201.1 General: For the purposes of this Code, certain terms, phrases, words, and their derivatives shall be construed as specified in this section. Words used is the singular include the plural and the plural, the singular. Words used in the masculine gender include the feminine and feminine, the masculine.

(2003 Ed.)

Where terms are not defined in this section, the definitions shall be taken from Chapter 2 of the Uniform Building Code.

Where terms are not defined in either this section or Chapter 2 of the Uniform Building Code, they shall have their ordinary accepted meanings within the context with which they are used. Webster's Third International Dictionary of the English Language, Unabridged, copyrighted 1986, shall be considered as providing ordinarily accepted meanings.

[Statutory Authority: RCW 19.27.190. 95-01-128, § 51-13-201, filed 12/21/94, effective 6/30/95; 91-01-102, § 51-13-201, filed 12/18/90, effective 7/1/91.]

WAC 51-13-202 Definitions.

Addition: An extension or increase in floor area or height of a building or structure.

Aggregate: Crushed stone, stone, or other inert material, or combinations thereof having hard, strong, durable pieces.

Air barrier: A continuous material or system of materials utilized for the purpose of minimizing the movement of air across a defined boundary, and capable of withstanding the maximum pressure developed across it, without failing by becoming significantly more leaky.

Air, exhaust: Air removed from a space and not reused therein.

Air, outdoor: Air taken from the external atmosphere and, therefore, not previously circulated through the HVAC system or the conditioned space.

Air, supply: That air delivered to the conditioned space and used for ventilation, heating, cooling, humidification, or dehumidification.

Air, transfer: The movement of indoor air from one space to another.

Air, ventilation: That portion of supply air that is outdoor air plus any recirculated air that has been treated for the purpose of maintaining acceptable indoor air quality.

AMCA: Air Movement and Control Association, Inc.

Approved: As to material and types of construction, refers to approved by the building official as the result of investigation and tests conducted by him, or by reason of accepted principles or tests by recognized authorities, technical or scientific organizations.

ASHRAE: American Society of Heating, Refrigerating, and Air Conditioning Engineers, Inc.

Automatic: Self-acting, operating by its own mechanism when actuated by some impersonal influence, as for example, a change in current strength, pressure, temperature, or mechanical configuration.

Back-draft damper: A damper installed to restrict introduction of unconditioned air from an unconditioned space to a conditioned space.

Barometric damper: Shall be any listed nonmanual device that freely allows the flow of air in one direction, but does not allow conditioned air to escape. Any installed combustion air damper shall meet the installation requirements of the manufacturer.

Building official: The officer or other designated authority charged with the administration and enforcement of this Code, or his duly authorized representative.

Certified local government: The local government has been certified by the state historical preservation officer as having established its own historic preservation commission and a program meeting federal and state standards.

CFM: Cubic feet per minute.

Conditioned floor area: The floor area within the conditioned space.

Conditioned space: That part of a building that is heated or cooled or both for the comfort of occupants.

Dehumidistat: An automatic control device which measures changes in humidity and controls a device(s) for maintaining a maximum specified humidity range or level.

Exfiltration: The uncontrolled outward air leakage through cracks and concealed spaces in any building element and around sole plates, wall outlets, duct systems, windows, and doors of a building, caused by the pressure effect of wind and/or the effect of differences in the indoor and outdoor air density.

Gravel: A type of aggregate.

Habitable space (room): Space in a structure for living, sleeping, eating, or cooking. Bathrooms, toilet compartments, closets, halls, storage, or utility space and similar areas, are not considered habitable space. For the purpose of this Code, a single habitable space may consist of adjoining rooms when one half of the area of the common wall is open and unobstructed and provides an opening of not less than one-tenth of the floor area of the interior room or twenty five square feet, whichever is greater.

Heat recovery ventilation system: A device or combination of devices applied to provide the outdoor air for ventilation in which energy is transferred between the intake and exhaust airstream.

Historic buildings: Any structure, collection of structures, and their associated sites, deemed of importance to the history, architecture, or culture of an area by an appropriate local, state, or federal government jurisdiction. This includes structures on official national, state, or local listings such as the National Register of Historic Places, the State Register of Historic Places, state points of historical interest, and registers or listings of historical or architecturally significant sites,

places, historic districts, or landmarks as adopted by a certified local government.

Humidistat: An automatic control device which measures changes in humidity and controls a device(s) for maintaining a minimum specified humidity range or level.

HVAC: Heating, ventilating, and air conditioning.

HVI: Home Ventilating Institute of America, Inc.

Infiltration: The uncontrolled inward air leakage through cracks and concealed spaces in any building element and around sole plates, wall outlets, duct systems, windows, and doors of a building, caused by the pressure effect of wind and/or the effect of differences in the indoor and outdoor air density.

"J" Definitions: (Reserved)

"K" Definitions: (Reserved)

"L" Definitions: (Reserved)

Manual: Capable of being operated by human intervention.

Masonry heater: A heating system which is predominantly masonry construction, having a mass of at least 1764 pounds (800 kg) excluding chimney and base. Within the masonry mass are contained a firebox and multiple heat exchange channels which store the heat and allow for extremely high temperature fires to be burned.

Mitigate: To design, select, apply, and install systems, materials, and processes that reduce radon concentrations in the indoor air of a building, and/or prevent entry of radon into the indoor air of a building, so that the average indoor radon concentration is reduced to an acceptable level.

New construction: Any building, addition or change in occupancy permitted on or after the effective date of this Code.

"O" Definitions: (Reserved)

Picocurie, pCi: A measure of radioactive activity equal to one trillion of a curie. A curie is the amount of any radionuclide that undergoes thirty seven billion nuclear disintegrations per second, hence a picocurie is .037 nuclear disintegrations per second.

Picocurie per liter, pCi/L: A common unit of measurement of the concentration of radioactivity in a gas. One pCi/L corresponds to 2.22 radioactive disintegrations per minute per liter of air.

"Q" Definitions: (Reserved)

R value: (See **Thermal resistance (R)**)

Readily accessible: Readily accessible means capable of being reached safely and quickly for operation, repair, or inspections, without requiring those to whom ready access is requisite to climb over or remove obstacles, or to resort to the use of portable access equipment.

Soil depressurization system (SDS): A radon control technique that depressurizes the space below a concrete slab or other soil gas retarder relative to the space above it. The purpose of SDS is to maintain a slightly lower pressure in the soil gas under the slab or other soil gas retarder, compared to the indoor pressure above it, to ensure that flows are from the indoors to the soil, thus preventing mass transport of radon contaminated soil gas to the indoor air.

Soil gas retarder membrane: A flexible sheet material placed between the soil and the indoor air for the purpose of reducing the flow of soil gas into the building.

Solid fuel burning appliance: Any factory-built appliance designed to burn solid fuels.

Source specific ventilation system: A mechanical ventilation system including all fans, controls, and ducting, which is dedicated to exhausting contaminant-laden air to the exterior of the building from the room or space in which the contaminant is generated.

System: A combination of equipment and/or controls, accessories, interconnecting means, and terminal elements by which air is transferred.

Terminal element: The means by which the transferred air from a system is finally delivered; i.e., registers, diffusers, through-the-wall vents, roof caps, etc.

Thermal resistance (R): The resistance of a material to heat flow, measured as the inverse of heat flow per unit area, per unit time, per unit temperature difference across the thickness of material considered. In this Code, R has units of sq.ft./hr.°F/Btu.

Thermostat: An instrument which measures changes in temperature and control device(s) for maintaining a desired temperature.

Unconditioned space: (See **Conditioned space**)

Ventilation: The process of supplying and removing air by natural or mechanical means to and from any space. Such air may or may not be conditioned.

Ventilation, mechanical: The introduction and distribution of outdoor air and the removal of indoor air by mechanical means.

Ventilation, natural: Ventilation other than by mechanical means.

Virgin polyethylene: Extruded polyethylene sheets made from nonreprocessed resins.

Whole house ventilation system: A mechanical ventilation system, including fans, controls, and ducts, which replaces, by direct or indirect means, air from the habitable rooms with outdoor air.

Wood stove: (See **Solid fuel burning appliance**)

"X" Definitions: (Reserved)

"Y" Definitions: (Reserved)

Zone: A space or group of spaces within a building with heating and/or cooling requirements sufficiently similar so that comfort conditions can be maintained throughout by a single controlling device.

[Statutory Authority: RCW 19.27.190(2) and 1992 c 132. 93-02-056, § 51-13-202, filed 1/6/93, effective 7/1/93. Statutory Authority: RCW 19.27.190. 91-01-102, § 51-13-202, filed 12/18/90, effective 7/1/91.]

WAC 51-13-300 Chapter 3—Ventilation systems.

[Statutory Authority: RCW 19.27.190(2) and 1992 c 132. 93-02-056, § 51-13-300, filed 1/6/93, effective 7/1/93. Statutory Authority: RCW 19.27.190. 91-01-102, § 51-13-300, filed 12/18/90, effective 7/1/91.]

WAC 51-13-301 Compliance with this chapter.

301.1 General: The criteria of this chapter establish the design conditions upon which the minimum ventilation systems are to be based for all occupancies. Group R Occupancies four (4) stories and less as defined by the Washington State Building Code shall comply with either Section 302 or 303. Section 304 applies to all other occupancies.

301.2 Testing: At the discretion of the building official, flow testing may be required to verify that the mechanical system(s) satisfies the requirements of this section. Flow testing may be performed using flow hoods measuring at the intake or exhaust points of the system, in-line pitot tube, or pitot-traverse type measurement systems in the duct, short term tracer gas measurements, or other means approved by the building official.

[Statutory Authority: RCW 19.27.190, 19.27.020. 01-02-099, § 51-13-301, filed 1/3/01, effective 7/1/01. Statutory Authority: RCW 19.27.190. 91-01-102, § 51-13-301, filed 12/18/90, effective 7/1/91.]

WAC 51-13-302 Mechanical ventilation criteria using performance or design methods for Group R Occupancies four stories and less.

302.1 Applicability: Group R Occupancies four (4) stories and less as defined by the Washington State Building Code shall comply with either this section or Section 303.

302.1.1 Compliance by Calculations or Testing: Compliance with this section shall be demonstrated through engineering calculation or performance testing. Documentation of calculations or performance test results shall be submitted to the building official. Performance testing shall be conducted in accordance with recognized test methods.

302.1.2 Minimum Ventilation Performance: Each dwelling unit or guest room shall be equipped with source specific and whole house ventilation systems designed and installed to satisfy the ventilation requirements of this section.

All public corridors shall meet the ventilation requirements in section 1203.3 of the Uniform Building Code.

302.2 Source Specific Ventilation Requirements.

302.2.1 Source Specific Ventilation: Source specific exhaust ventilation is required in each kitchen, bathroom, water closet, laundry room, indoor swimming pool, spa, and

other rooms where excess water vapor or cooking odor is produced.

The minimum source specific ventilation effective exhaust capacity shall be not less than levels specified in Table 3-1.

302.2.2 Source Specific Ventilation Controls: Source specific ventilation systems shall be controlled by manual switches, dehumidistats, timers, or other approved means. Source specific ventilation system controls shall be readily accessible.

302.2.3 Source Specific Ventilation Ducts: Source specific ventilation ducts shall terminate outside the building. Exhaust ducts in systems which are designed to operate intermittently shall be equipped with back-draft dampers. All exhaust ducts in unconditioned spaces shall be insulated to a minimum of R-4. Terminal elements shall have at least the equivalent net free area of the duct work. Terminal elements for exhaust fan duct systems shall be screened or otherwise protected from entry by leaves or other material.

302.3 Requirements for Whole House Ventilation Systems.

302.3.1 Whole House Ventilation Systems: Each dwelling unit shall be equipped with a whole house ventilation system which shall be capable of providing the volume of outdoor air specified in Table 3-2 under normal operating conditions.

EXCEPTION: Maximum flow rates listed in Table 3-2 do not apply to heat recovery ventilation systems.

302.3.2 Whole House Ventilation System Controls: All ventilation system controls shall be readily accessible. Controls for whole house ventilation systems shall be capable of operating the ventilation system without energizing other energy-consuming appliances.

Intermittently operated whole house ventilation systems shall be constructed to have the capability for continuous operation, and shall have a manual control and an automatic control, such as a clock timer. At the time of final inspection, the automatic control timer shall be set to operate the whole house fan for at least eight hours a day. A label shall be affixed to the control that reads "Whole House Ventilation (see operating instructions)."

302.3.3 Fan Noise: Whole house fans located four feet or less from the interior grille shall have a sone rating of 1.5 or less measured at 0.1 inches water gauge. Manufacturer's noise ratings shall be determined as per HVI 915 (October 1995). Remotely mounted fans shall be acoustically isolated from the structural elements of the building and from attached duct work using insulated flexible duct or other approved material.

EXCEPTION: Whole house ventilation systems which are integrated with forced-air heating systems or heat-recovery ventilation systems are exempt from the sone rating requirements of this section.

302.3.4 Whole House Ventilation Ducts: All ducts shall terminate outside the building. Exhaust ducts in systems which are designed to operate intermittently shall be

equipped with back-draft dampers. All exhaust ducts in unconditioned spaces shall be insulated to a minimum of R-4. All supply ducts in the conditioned space shall be insulated to a minimum of R-4.

302.3.5 Outdoor Air.

302.3.5.1 Outdoor Air Supply: A mechanical system shall supply outdoor air as required in Section 302.3.1. The mechanical system may consist of exhaust fans, supply fans, or both.

302.3.5.2 Outdoor Air Inlets: Inlets shall be screened or otherwise protected from entry by leaves or other material. Outdoor air inlets shall be located so as not to take air from the following areas:

- a) Closer than ten feet from an appliance vent outlet, unless such vent outlet is three feet above the outdoor air inlet.
- b) Where it will pick up objectionable odors, fumes, or flammable vapors.
- c) A hazardous or unsanitary location.
- d) A room or space having any fuel-burning appliances therein.
- e) Closer than ten feet from a vent opening of a plumbing drainage system unless the vent opening is at least three feet above the air inlet.
- f) Attic, crawl spaces, garages.

302.3.5.3 Outdoor Air Distribution: Outdoor air shall be distributed to each habitable room by means such as individual inlets, separate duct systems, or a forced-air system. Where outdoor air supplies are separated from exhaust points by doors, provisions shall be made to ensure air flow by installation of distribution ducts, undercutting doors, installation of grilles, transoms, or similar means where permitted by the Uniform Building Code. Doors shall be undercut to a minimum of one-half inch above the surface of the finish floor covering.

302.3.5.4 Doors and operable lites in windows: are deemed not to meet the outdoor air supply intake requirements.

302.3.5.5 Individual Room Outdoor Air Inlets: Where provided, individual room outdoor air inlets shall:

- a) Have controllable and secure openings;
- b) Be sleeved or otherwise designed so as not to compromise the thermal properties of the wall or window in which they are placed.

302.3.5.6 Ventilation Integrated with Forced-Air Systems: Where outdoor air is provided by a forced-air system, the outdoor air connection to the return air stream shall be located upstream of the forced-air system blower and shall not be connected directly into a furnace cabinet to prevent thermal shock to the heat exchanger.

[Statutory Authority: RCW 19.27.190, 19.27.020, 01-02-099, § 51-13-302, filed 1/3/01, effective 7/1/01. Statutory Authority: RCW 19.27.190, 95-01-128, § 51-13-302, filed 12/21/94, effective 6/30/95. Statutory Authority: RCW 19.27.190(2) and 1992 c 132, 93-02-056, § 51-13-302, filed 1/6/93,

effective 7/1/93. Statutory Authority: RCW 19.27.190. 91-01-102, § 51-13-302, filed 12/18/90, effective 7/1/91.]

WAC 51-13-303 Mechanical ventilation criteria using prescriptive methods for Group R Occupancies four stories and less.

303.1 Applicability: Group R Occupancies 4 stories or less shall comply with this section or Section 302. This section establishes minimum prescriptive design requirements for intermittently operated systems. Continuously operated systems shall comply with Section 302. A system which meets the requirements of this section shall be deemed to satisfy the requirements of this chapter.

303.2 Minimum Ventilation Performance: Each dwelling unit or guest room shall be equipped with source specific and whole house ventilation systems designed and installed to satisfy the ventilation requirements of this section. All public corridors shall meet the ventilation requirements in Section 1203.3 of the Uniform Building Code.

303.3 Source Specific Exhaust Ventilation Requirements.

303.3.1 Source Specific Ventilation: Source specific exhaust ventilation is required in each kitchen, bathroom, water closet, laundry room, indoor swimming pool, spa, and other rooms where excess water vapor or cooking odor is produced. The minimum source specific ventilation effective exhaust capacity shall be not less than levels specified in Table 3-1.

303.3.2 Source Specific Exhaust Fans: Exhaust fans providing source specific ventilation shall have a minimum fan flow rating not less than 50 cfm at 0.25 inches water gauge for bathrooms, laundries, or similar rooms and 100 cfm at 0.25 inches water gauge for kitchens. Manufacturers' fan flow ratings shall be determined as per HVI 916 (April 1995) or AMCA 210.

EXCEPTION: Where a range hood or down draft exhaust fan is used to satisfy the source specific ventilation requirements for kitchens, the range hood or down draft exhaust shall not be less than 100 cfm at 0.10 inches water gauge.

303.3.3 Source Specific Ventilation Controls: Source specific ventilation systems shall be controlled by manual switches, dehumidistats, timers, or other approved means. Source specific ventilation system controls shall be readily accessible.

303.3.4 Source Specific Ventilation Ducts: Source specific ventilation ducts shall terminate outside the building. Exhaust ducts shall be equipped with back-draft dampers. All exhaust ducts in unconditioned spaces shall be insulated to a minimum of R-4. Terminal elements shall have at least the equivalent net free area of the duct work. Terminal elements for exhaust fan duct systems shall be screened or otherwise protected from entry by leaves or other material.

303.4 Prescriptive Whole House Ventilation Systems: Whole house ventilation shall be provided by a system that meets the requirements of either Section 303.3.1, 303.3.2, 303.3.3, or 303.3.4. A system which meets all of the require-

ments of one of these sections shall be deemed to satisfy the requirements for a whole house ventilation system.

303.4.1 Intermittent Whole House Ventilation Using Exhaust Fans: This section establishes minimum prescriptive requirements for intermittent whole house ventilation systems using exhaust fans. A system which meets all the requirements of this section shall be deemed to satisfy the requirements for a whole house ventilation system.

303.4.1.1 Whole House Ventilation Fans: Exhaust fans providing whole house ventilation shall have a flow rating at 0.25 inches water gauge as specified in Table 3-2. Manufacturers' fan flow ratings shall be determined according to HVI 916 (April 1995) or AMCA 210.

303.4.1.2 Fan Noise: Whole house fans located four feet or less from the interior grille shall have a sone rating of 1.5 or less measured at 0.1 inches water gauge. Manufacturer's noise ratings shall be determined as per HVI 915 (October 1995). Remotely mounted fans shall be acoustically isolated from the structural elements of the building and from attached duct work using insulated flexible duct or other approved material.

303.4.1.3 Fan Controls: The whole house ventilation fan shall be controlled by a 24-hour clock timer with the capability of continuous operation, manual and automatic control. The 24-hour timer shall be readily accessible. The 24-hour timer shall be capable of operating the whole house ventilation fan without energizing other energy-consuming appliances. At the time of final inspection, the automatic control timer shall be set to operate the whole house fan for at least eight hours a day. A label shall be affixed to the control that reads "Whole House Ventilation (see operating instructions)."

303.4.1.4 Exhaust Ducts: All exhaust ducts shall terminate outside the building. Exhaust ducts shall be equipped with back-draft dampers. All exhaust ducts in unconditioned spaces shall be insulated to a minimum of R-4.

303.4.1.5 Outdoor Air Inlets: Outdoor air shall be distributed to each habitable room by individual outdoor air inlets. Where outdoor air supplies are separated from exhaust points by doors, provisions shall be made to ensure air flow by installation of distribution ducts, undercutting doors, installation of grilles, transoms, or similar means where permitted by the Uniform Building Code. Doors shall be undercut to a minimum of one-half inch above the surface of the finish floor covering.

Individual room outdoor air inlets shall:

- a. Have controllable and secure openings;
- b. Be sleeved or otherwise designed so as not to compromise the thermal properties of the wall or window in which they are placed;
- c. Provide not less than four square inches of net free area of opening for each habitable space. Any inlet or combination of inlets which provide 10 cfm at 10 Pascals as determined by the Home Ventilating Institute Air Flow Test Standard (HVI 901 (November 1996)) are deemed equivalent to four square inches net free area.

Inlets shall be screened or otherwise protected from entry by leaves or other material. Outdoor air inlets shall be located so as not to take air from the following areas:

- a. Closer than 10 feet from an appliance vent outlet, unless such vent outlet is 3 feet above the outdoor air inlet.
- b. Where it will pick up objectionable odors, fumes or flammable vapors.
- c. A hazardous or unsanitary location.
- d. A room or space having any fuel-burning appliances therein.
- e. Closer than 10 feet from a vent opening of a plumbing drainage system unless the vent opening is at least 3 feet above the air inlet.
- f. Attic, crawl spaces, or garages.

EXCEPTION: Exhaust only ventilation systems do not require outdoor air inlets if the home has a ducted forced air heating system that communicates with all habitable rooms and the interior doors are undercut to a minimum of one-half inch above the surface of the finish floor covering.

303.4.2 Prescriptive Requirements for Intermittent Whole House Ventilation Integrated with a Forced-Air System: This section establishes minimum prescriptive requirements for intermittent whole house ventilation systems integrated with forced-air ventilation systems. A system which meets all the requirements of this section shall be deemed to satisfy the requirements for a whole house ventilation system.

303.4.2.1 Integrated Whole House Ventilation Systems: Integrated Whole House Ventilation Systems shall provide outdoor air at the rates specified in Table 3-2. Integrated Forced-Air Ventilation Systems shall distribute outdoor air to each habitable room through the forced-air system ducts. Integrated Forced-Air Ventilation Systems shall have an outdoor air inlet duct connecting a terminal element on the outside of the building to the return air plenum of the forced-air system, at a point within four (4) feet upstream of the air handler. The outdoor air inlet duct connection to the return air stream shall be located upstream of the forced-air system blower and shall not be connected directly into a furnace cabinet to prevent thermal shock to the heat exchanger. The outdoor air inlet duct shall be prescriptively sized in accordance with Table 3-5. The system will be equipped with one of the following:

1. A motorized damper connected to the automatic ventilation control as specified in Section 303.3.2.2; or
2. A damper installed and set to meet minimum flow rates as specified in Table 3-2, by either field testing or following manufacturer's installation instructions based on site conditions; or
3. An automatic flow regulated device with field measured or field calculated minimum negative pressure of 0.07 inches water gauge at the point where the outside air duct is connected to the return air plenum.

303.4.2.2 Ventilation Controls: The whole house ventilation system shall be controlled by a 24-hour clock timer with the capability of continuous operation, manual and automatic control. This control will control the forced air system blower and if applicable the automatic damper. The 24-hour timer shall be readily accessible. The 24-hour timer shall be capable of operating the whole house ventilation system

without energizing other energy-consuming appliances. At the time of final inspection, the automatic control timer shall be set to operate the whole house system for at least eight hours a day. A label shall be affixed to the control that reads "Whole House Ventilation (see operating instructions)."

303.4.2.3 Ventilation Duct Insulation: All supply ducts in the conditioned space shall be insulated to a minimum of R-4.

303.4.2.4 Outdoor Air Inlets: Inlets shall be screened or otherwise protected from entry by leaves or other material. Outdoor air inlets shall be located so as not to take air from the following areas:

- a. Closer than 10 feet from an appliance vent outlet, unless such vent outlet is 3 feet above the outdoor air inlet.
- b. Where it will pick up objectionable odors, fumes or flammable vapors.
- c. A hazardous or unsanitary location.
- d. A room or space having any fuel-burning appliances therein.
- e. Closer than 10 feet from a vent opening of a plumbing drainage system unless the vent opening is at least 3 feet above the air inlet.
- f. Attic, crawl spaces, or garages.

303.4.3 Prescriptive Requirements for Intermittent Whole House Ventilation Using a Supply Fan: This section establishes minimum prescriptive requirements for intermittent whole house ventilation systems using an inline supply fan. A system which meets all the requirements of this section shall be deemed to satisfy the requirements for a whole house ventilation system.

303.4.3.1 Outdoor Air: Supply Fan Ventilation Systems shall distribute outdoor air to each habitable room through the forced-air system ducts or through dedicated ducts to each habitable room. Supply fans shall have the capacity to provide the amount of outdoor air specified in Table 3-2 at 0.4 inches water gauge as per HVI 916 (April 1995). The outdoor air must be filtered before it is delivered to habitable rooms. The filter may be located at the intake device, inline with the fan, or, in the case of a connection to the return plenum of the airhandler, using the furnace filter. An outdoor air inlet shall be connected to either the supply or return air stream.

303.4.3.2 Ducts: An outdoor air inlet duct connection to the supply air stream shall be located downstream of the forced-air system blower. An outdoor air inlet duct connection to the return air stream shall be located at least four feet upstream of the forced-air system blower and its filter. Neither type of duct shall be connected directly into a furnace cabinet to prevent thermal shock to the heat exchanger. The outdoor air inlet duct shall be prescriptively sized in accordance with Table 3-6. The terminal element on the outside of the building shall be sized two inches in diameter larger than the outdoor air inlet duct.

303.4.3.3 Dampers: The system shall be equipped with a back-draft damper and one of the following:

1. A calibrated manual volume damper installed and set to meet the measured flow rates specified in Table 3-2 by

field testing with a pressure gauge and/or following manufacturer's installation instructions, or

2. A manual volume damper installed and set to meet the measured flow rates specified in Table 3-2 by field testing with a flow hood or a flow measuring station; or

3. An automatic flow-regulating device sized to the specified flow rates in Table 3-2 which provides constant flow over a pressure range of 0.2 to 0.6 inches water gauge.

303.4.3.4 Ventilation Controls: The whole house ventilation system shall be controlled by a 24 hour clock timer with the capability of continuous operation, manual and automatic control. This control will control the inline supply fan. The 24-hour timer shall be readily accessible. The 24 hour timer shall be capable of operating the whole house ventilation system without energizing other energy-consuming appliances. At the time of final inspection, the automatic control timer shall be set to operate the whole house system for at least eight hours a day. A label shall be affixed to the control that reads "Whole House Ventilation (see operating instructions)."

303.4.3.5 Ventilation Duct Insulation: All supply ducts in the conditioned space shall be insulated to a minimum of R-4.

303.4.3.6 Outdoor Air Inlets: Inlets shall be screened or otherwise protected from entry by leaves or other material. Outdoor air inlets shall be located so as not to take air from the following areas:

- a. Closer than 10 feet from an appliance vent outlet, unless such vent outlet is 3 feet above the outdoor air inlet.
- b. Where it will pick up objectionable odors, fumes or flammable vapors.
- c. A hazardous or unsanitary location.
- d. A room or space having any fuel-burning appliances therein.
- e. Closer than 10 feet from a vent opening of a plumbing drainage system unless the vent opening is at least 3 feet above the air inlet.
- f. Attic, crawl spaces, or garages.

303.4.4 Prescriptive Requirements for Intermittent Whole House Ventilation Using a Heat Recovery Ventilation System: This section establishes minimum prescriptive requirements for intermittent whole house ventilation using a heat recovery ventilation system.

303.4.4.1 Heat Recovery Ventilation Systems: All duct work in heat recovery ventilation systems shall be not less than six inch diameter. Balancing dampers shall be installed on the inlet and exhaust side. Flow measurement grids shall be installed on the supply and return. System minimum flow rating shall be not less than that specified in Table 3-2. Maximum flow rates in Table 3-2 do not apply to heat recovery ventilation systems.

303.4.4.2 Ventilation Controls: The whole house ventilation system shall be controlled by a 24 hour clock timer with the capability of continuous operation, manual and automatic control. This control will control the inline supply fan. The 24-hour timer shall be readily accessible. The 24 hour timer shall be capable of operating the whole house ventila-

(2003 Ed.)

tion system without energizing other energy-consuming appliances. At the time of final inspection, the automatic control timer shall be set to operate the whole house system for at least eight hours a day. A label shall be affixed to the control that reads "Whole House Ventilation (see operating instructions)."

303.4.4.3 Ventilation Duct Insulation: All supply ducts in the conditioned space installed upstream of the heat exchanger shall be insulated to a minimum of R-4.

303.4.4.4 Outdoor Air Inlets: Inlets shall be screened or otherwise protected from entry by leaves or other material. Outdoor air inlets shall be located so as not to take air from the following areas:

- a. Closer than 10 feet from an appliance vent outlet, unless such vent outlet is 3 feet above the outdoor air inlet.
- b. Where it will pick up objectionable odors, fumes or flammable vapors.
- c. A hazardous or unsanitary location.
- d. A room or space having any fuel-burning appliances therein.
- e. Closer than 10 feet from a vent opening of a plumbing drainage system unless the vent opening is at least 3 feet above the air inlet.
- f. Attic, crawl spaces, or garages.

[Statutory Authority: RCW 19.27.190, 19.27.020, 01-02-099, § 51-13-303, filed 1/3/01, effective 7/1/01. Statutory Authority: RCW 19.27.190(2) and 1992 c 132, 93-02-056, § 51-13-303, filed 1/6/93, effective 7/1/93. Statutory Authority: RCW 19.27.190, 91-01-102, § 51-13-303, filed 12/18/90, effective 7/1/91.]

WAC 51-13-304 Mechanical ventilation criteria and minimum ventilation performance for all other occupancies not covered in sections 302 and 303.

304.1 Ventilation: The minimum requirements for operable area to provide natural ventilation are specified in the Uniform Building Code (UBC) as adopted by the state of Washington.

Where a mechanical ventilation system is installed, the mechanical ventilation system shall be capable of supplying ventilation air to each zone with the minimum outdoor air quantities specified in Table 3-4.

EXCEPTION: Where occupancy density is known and documented in the plans, the outside air rate may be based on the design occupant density. Under no circumstance shall the occupancies used result in outside air less than one-half that resulting from application of Table 3-4 estimated maximum occupancy values.

The outdoor air shall be ducted in a fully enclosed path directly to every air handling unit in each zone not provided with sufficient operable area for natural ventilation.

EXCEPTION: Ducts may terminate within 12 inches of the intake to an HVAC unit provided they are physically fastened so that the outside air duct is directed into the unit intake.

In all parking garages, other than open parking garages as defined in UBC 311.9, used for storing or handling of automobiles operating under their own power and on all loading platforms in bus terminals, ventilation shall be provided at 1.5 cfm per square foot of gross floor area. The building

official may approve an alternate ventilation system designed to exhaust a minimum fourteen thousand cfm for each operating vehicle. Such system shall be based on the anticipated instantaneous movement rate of vehicles but not less than 2.5 percent (or one vehicle) of the garage capacity. Automatic carbon monoxide sensing systems may be submitted for approval.

In all buildings used for the repair of automobiles, each repair stall shall be equipped with an exhaust extension duct, extending to the outside of the building, which if over ten feet in length, shall mechanically exhaust three hundred cfm. Connecting offices and waiting rooms shall be supplied with conditioned air under positive pressure.

Combustion air requirements shall conform to the requirements of Chapter 7 of the UMC.

Mechanical refrigerating equipment and rooms storing refrigerants shall conform to the requirements of Chapter 11 of the UMC.

304.2 Alternate Systems: Alternate systems designed in accordance with ASHRAE Standard 62.1.1999 shall be permitted.

TABLE 3-1
Minimum Source Specific Ventilation Capacity Requirements

	Bathrooms	Kitchens
Intermittently operating	50 cfm	100 cfm
Continuous operation	20 cfm	25 cfm

TABLE 3-2
Ventilation Rates For All Group R Occupancies four (4) stories and less*
Minimum and Maximum Ventilation Rates: Cubic Feet Per Minute (CFM)

Floor Area, ft ²	Bedrooms													
	2 or less		3		4		5		6		7		8	
	Min.	Max.	Min.	Max.	Min.	Max.	Min.	Max.	Min.	Max.	Min.	Max.	Min.	Max.
<500	50	75	65	98	80	120	95	143	110	165	125	188	140	210
501-1000	55	83	70	105	85	128	100	150	115	173	130	195	145	218
1001-1500	60	90	75	113	90	135	105	158	120	180	135	203	150	225
1501-2000	65	98	80	120	95	143	110	165	125	188	140	210	155	233
2001-2500	70	105	85	128	100	150	115	173	130	195	145	218	160	240
2501-3000	75	113	90	135	105	158	120	180	135	203	150	225	165	248
3001-3500	80	120	95	143	110	165	125	188	140	210	155	233	170	255
3501-4000	85	128	100	150	115	173	130	195	145	218	160	240	175	263
4001-5000	95	143	110	165	125	188	140	210	155	233	170	255	185	278
5001-6000	105	158	120	180	135	203	150	225	165	248	180	270	195	293
6001-7000	115	173	130	195	145	218	160	240	175	263	190	285	205	308
7001-8000	125	188	140	210	155	233	170	255	185	278	200	300	215	323
8001-9000	135	203	150	225	165	248	180	270	195	293	210	315	225	338
>9000	145	218	160	240	175	263	190	285	205	308	220	330	235	353

*For residences that exceed 8 bedrooms, increase the minimum requirement listed for 8 bedrooms by an additional 15 CFM per bedroom. The maximum CFM is equal to 1.5 times the minimum.

TABLE 3-3
Prescriptive Exhaust Duct Sizing

Fan Tested CFM @ 0.25 W.G.	Minimum Flex Diameter	Maximum Length Feet	Minimum Smooth Diameter	Maximum Length Feet	Maximum Elbows ¹
50	4 inch	25	4 inch	70	3
50	5 inch	90	5 inch	100	3
50	6 inch	No Limit	6 inch	No Limit	3
80	4 inch ²	NA	4 inch	20	3
80	5 inch	15	5 inch	100	3
80	6 inch	90	6 inch	No Limit	3
100	5 inch ²	NA	5 inch	50	3
100	6 inch	45	6 inch	No Limit	3
125	6 inch	15	6 inch	No Limit	3
125	7 inch	70	7 inch	No Limit	3

- For each additional elbow subtract 10 feet from length.
- Flex ducts of this diameter are not permitted with fans of this size.

TABLE 3-4
Outdoor air requirements for ventilation¹
Occupancies not subject to sections 302 and 303

Application	Estimated Maximum ² Occupancy P/1000 ft ² or 100 m ²	Outdoor Air Requirements cfm/person
Dry Cleaners, Laundries³		
Commercial laundry	10	25
Commercial dry cleaner	30	30
Storage, pick up	30	35
Coin-operated laundries	20	15
Coin-operated dry cleaner	20	15
Dwelling Units In Buildings Greater Than Four Stories or Attached to I-Occupancy Facilities		
Bedroom & living area ²⁴		15
Food and Beverage Service		
Dining rooms	70	20
Cafeteria, fast food	100	20
Bars, cocktail lounges ⁴	100	30
Kitchens (cooking) ²³	20	15
Garages, Repair, Service Stations		
Enclosed parking garage ⁵		1.50 cfm/ft.sq.
Auto repair rooms		1.50 cfm/ft.sq.
Hotels, Motels, Resorts, Congregate Residences with More Than Four Stories⁶		

Application	Estimated Maximum ² Occupancy P/1000 ft ² or 100 m ²	Outdoor Air Requirements cfm/person
Bedrooms		30 cfm/room
Living Rooms		30 cfm/room
Bath ⁷		35 cfm/room
Lobbies	30	15
Conference rooms	50	20
Assembly rooms	120	15
Gambling casinos ⁴	120	30
Offices		
Office space ⁹	7	20
Reception area	60	15
Telecommunication centers and data entry areas	60	20
Conference rooms	50	20
Public Spaces		
Corridors and utilities		0.05 cfm/ft.sq.
Public restroom, cfm/wc or urinal ¹⁰		50
Lockers and dressing rooms		0.50 cfm/ft.sq.
Smoking lounge ¹¹	70	60
Elevators ¹²		1.0 cfm/ft.sq.
Retail Stores, Sales Floors, and Show Room Floors		
Basement and street	30	0.30 cfm/ft.sq.
Upper floors	20	0.20 cfm/ft.sq.
Storage rooms	15	0.15 cfm/ft.sq.
Dressing rooms		0.20 cfm/ft.sq.
Malls and arcades	20	0.20 cfm/ft.sq.
Shipping and receiving	10	0.15 cfm/ft.sq.
Smoking lounge ¹¹	70	60
Warehouses	5	0.05 cfm/ft.sq.
Specialty Shops		
Barber	25	15
Beauty	25	25
Reducing salons	20	15
Florists ¹³	8	15
Clothiers, furniture		0.30 cfm/ft.sq.
Hardware, drugs, fabric	8	15
Supermarkets	8	15
Pet shops		1.00 cfm/ft.sq.
Sports and Amusement¹⁴		
Spectator areas	150	15
Game rooms	70	25
Ice arenas (playing areas)		0.50 cfm/ft.sq.
Swimming Pools (pool and deck area) ¹⁵		0.50 cfm/ft.sq.
Playing floor (gymnasium)	30	20
Ballrooms and discos	100	25
Bowling alleys (seating areas)	70	25
Theaters¹⁶		
Ticket booths	60	20
Lobbies	150	20
Auditorium	150	20
Stages, studios	70	15
Transportation¹⁷		
Waiting rooms	100	15
Platforms	100	15
Vehicles	150	15
Workrooms		
Meat processing ¹⁸	10	15
Photo studios	10	15
Darkrooms	10	0.50 cfm/ft.sq.
Pharmacy	20	15
Bank vaults	5	15
Duplicating, printing ¹⁹		0.50 cfm/ft.sq.
INSTITUTIONAL FACILITIES		
Education		
Classroom	50	15
Laboratories ²⁰	30	20
Training shop	30	20

Application	Estimated Maximum ² Occupancy P/1000 ft ² or 100 m ²	Outdoor Air Requirements cfm/person
Music rooms	50	15
Libraries	20	15
Locker rooms		0.50 cfm/ft.sq.
Corridors		0.10 cfm/ft.sq.
Auditoriums	150	15
Smoking lounges ¹¹	70	60
Hospitals, Nursing and Convalescent Homes		
Patient rooms ²¹	10	25
Medical procedure	20	15
Operating rooms	20	30
Recovery and ICU	20	15
Autopsy rooms ²²		0.50 cfm/ft.sq.
Physical Therapy	20	15
Correctional Facilities		
Cells	20	20
Dining halls	100	15
Guard station	40	15

- Derived from ASHRAE Standard 62-1989.
- Net occupiable space.
- Dry-cleaning process may require more air.
- Supplementary smoke-removal equipment may be required.
- Distribution among people must consider worker location and concentration of running engine; stands where engines are run must incorporate systems for positive engine exhaust withdrawal. Contaminant sensors may be used to control ventilation.
- Independent of room size.
- Installed capacity for intermittent use.
- See also food and beverage service, merchandising, barber and beauty shops, garages.
- Some office equipment may require local exhaust.
- Mechanical exhaust with no recirculation is recommended.
- Normally supplied by transfer air, local mechanical exhaust; with no recirculation recommended.
- Normally supplied by transfer air.
- Ventilation to optimize plant growth may dictate requirements.
- When internal combustion engines are operated for maintenance of playing surfaces, increased ventilation rates may be required.
- Higher values may be required for humidity control.
- Special ventilation will be needed to eliminate special stage effects.
- Ventilation within vehicles may require special considerations.
- Spaces maintained at low temperatures (-10°F. to+ 50°F.) are not covered by these requirements unless the occupancy is continuous. Ventilation from adjoining spaces is permissible. When the occupancy is intermittent, infiltration will normally exceed the ventilation requirements.
- Installed equipment must incorporate positive exhaust and control of undesirable contaminants.
- Special contamination control systems may be required for processes or functions including laboratory animal occupancy.
- Special requirements or codes and pressure relationships may determine minimum ventilation rates and filter efficiency. Procedures generating contaminants may require higher rates.
- Air shall not be recirculated into other spaces.
- Makeup air for hood exhaust may require more ventilating air.
- Occupant loading shall be based on the number of bedrooms as follows: first bedroom, two persons; each additional bedroom, one person. Where higher occupant loadings are known, they shall be used.

TABLE 3-5
Prescriptive Integrated Forced Air Supply Duct Sizing

Required Flow (CFM) Per Table 3-2	Minimum Smooth Duct Diameter	Minimum Flexible Duct Diameter	Maximum Length ¹	Maximum Number of Elbows ²
50-80	6"	7"	20'	3
80-125	7"	8"	20'	3
115-175	8"	10"	20'	3
170-240	9"	11"	20'	3

1. For lengths over 20 feet increase duct diameter 1 inch.
2. For elbows numbering more than 3 increase duct diameter 1 inch.

TABLE 3-6
Prescriptive Supply Fan Duct Sizing

Supply Fan Tested CFM At 0.4" WG		
Specified volume from Table 3-2	Minimum Smooth Duct Diameter	Minimum Flexible Duct Diameter
50-90 CFM	4 inch	5 inch
90-150 CFM	5 inch	6 inch
150-250 CFM	6 inch	7 inch
250-400 CFM	7 inch	8 inch

[Statutory Authority: RCW 19.27.190, 19.27.020, 01-02-099, § 51-13-304, filed 1/3/01, effective 7/1/01. Statutory Authority: RCW 19.27.190, 95-01-128, § 51-13-304, filed 12/21/94, effective 6/30/95. Statutory Authority: RCW 19.27.190(2) and 1992 c 132, 93-02-056, § 51-13-304, filed 1/6/93, effective 7/1/93. Statutory Authority: RCW 19.27.190, 91-01-102, § 51-13-304, filed 12/18/90, effective 7/1/91.]

WAC 51-13-400 Chapter 4—Indoor air quality.

[Statutory Authority: RCW 19.27.190, 91-01-102, § 51-13-400, filed 12/18/90, effective 7/1/91.]

WAC 51-13-401 Pollutant source control.

401.1 Formaldehyde Reduction Measures: All structural panel components within the conditioned space such as plywood, particle board, wafer board, and oriented strand board shall be identified as "EXPOSURE 1," "EXTERIOR" or "HUD-APPROVED."

[Statutory Authority: RCW 19.27.190(2) and 1992 c 132, 93-02-056, § 51-13-401, filed 1/6/93, effective 7/1/93. Statutory Authority: RCW 19.27.190, 91-01-102, § 51-13-401, filed 12/18/90, effective 7/1/91.]

WAC 51-13-402 Solid fuel burning appliances and fireplaces.

402.1 General: Solid fuel burning appliances and fireplaces shall satisfy one of the following criteria.

402.2 Solid Fuel Burning Appliances: Solid fuel burning appliances shall be provided with the following:

a) Tight fitting metal or ceramic glass doors.

b) 1. A source from outside the structure of primary combustion air, connected to the appliance as per manufacturer's specification. The air inlet shall originate at a point below the fire box. The duct shall be 4 inches or greater in diameter, not exceed 20 feet in length, and be installed as per manufacturer's instructions;

or

2. The appliance and manufacturer's recommended combustion air supply, as an installed unit, shall be certified by an independent testing laboratory to have passed Test No. 11 - Negative Pressure Test, Section 12.3, of ULC S627-M1984 "Space Heaters for Use with Solid Fuels," modified as follows:

[Title 51 WAC—p. 120]

A) Negative pressure of 8 Pascal shall be initially established with the chamber sealed and the air supply, if not directly connected to the appliance, closed off.

B) The air supply, if not directly connected to the appliance, shall then be opened.

C) The maximum allowable air exchange rate from chamber leakage and intentional air supply for the unit (appliance with combustion air supply) in the test chamber is 3.5 air changes per hour, or 28 cfm (cubic feet of air per minute), whichever is less.

EXCEPTION: Combustion air may be supplied to the room in which the solid fuel burning appliance is located in lieu of direct ducting, provided that one of the following conditions is met:

1) The solid fuel burning appliance is part of a central heating plant and installed in an unconditioned space in conformance with the Uniform Mechanical Code; or

2) The solid fuel burning appliance is installed in existing construction directly on a concrete floor or surrounded by masonry materials as in a fireplace.

The combustion air terminus shall be located as close to the solid fuel burning appliance as possible and shall be provided with a barometric damper or equivalent. The combustion air source shall be specified by the manufacturer or no less than four (4) inches in diameter or the equivalent in area or as approved.

402.3 Fireplaces: Fireplaces shall be provided with each of the following:

a) Tightly fitting flue dampers, operated by a readily accessible manual or approved automatic control.

EXCEPTION: Fireplaces with gas logs shall be installed in accordance with the Uniform Mechanical Code section 901.

b) An outside source for combustion air ducted into the firebox. The duct shall be at least six (6) square inches, and shall be provided with an operable outside air duct damper.

EXCEPTION: Washington certified fireplaces shall be installed with the combustion air systems necessary for their safe and efficient combustion and specified by the manufacturer in accordance with the Washington state UBC Standard 31-2 (WAC 51-40-31200) and UBC section 3102.5.4 (WAC 51-40-3102).

c) Site built fireplaces shall have tight fitting glass or metal doors, or a flue draft induction fan, or as approved for minimizing back-drafting. Factory built fireplaces shall use doors listed for the installed appliance.

402.4 Masonry Heaters: Masonry heaters shall be approved by the department of ecology and shall contain both of the following:

a) Primary combustion air ducted from the outside of the structure to the appliance.

b) Tight fitting ceramic glass or metal doors. Flue damper, when provided, shall have an external control and when in the closed position shall have a net free area of not less than five percent of the flue cross sectional area.

[Statutory Authority: RCW 19.27.190 and 19.27.020, 98-02-047, § 51-13-402, filed 1/5/98, effective 7/1/98. Statutory Authority: RCW 19.27.190, 95-01-128, § 51-13-402, filed 12/21/94, effective 6/30/95. Statutory Authority:

(2003 Ed.)

RCW 19.27.190(2) and 1992 c 132. 93-02-056, § 51-13-402, filed 1/6/93, effective 7/1/93. Statutory Authority: RCW 19.27.190. 91-01-102, § 51-13-402, filed 12/18/90, effective 7/1/91.]

WAC 51-13-500 Chapter 5—Radon resistive construction standards.

[Statutory Authority: RCW 19.27.190. 91-01-102, § 51-13-500, filed 12/18/90, effective 7/1/91.]

WAC 51-13-501 Scope.

501.1 General: The criteria of this chapter establishes minimum radon resistive construction requirements for all Group R Occupancies. These requirements are adopted pursuant to the ventilation requirements of Section 7, of Chapter 2 of the Session Laws of 1990.

501.2 Application: The requirements of this chapter shall be adopted and enforced by all jurisdictions of the state according to the following subsections:

501.2.1: All jurisdictions of the state shall comply with section 502.

501.2.2: Ferry, Okanogan, Pend Oreille, Skamania, Spokane, and Stevens counties shall also comply with section 503.

[Statutory Authority: RCW 19.27.190. 95-01-128, § 51-13-501, filed 12/21/94, effective 6/30/95; 91-01-102, § 51-13-501, filed 12/18/90, effective 7/1/91.]

WAC 51-13-502 Statewide radon requirements.

502.1 Crawlspace:

502.1.1 General: All crawlspaces shall comply with the requirements of this section.

502.1.2 Ventilation: All crawlspaces shall be ventilated as specified in section 2306.7 of the Washington State Uniform Building Code (chapter 51-40 WAC).

If the installed ventilation in a crawlspace is less than one square foot for each three hundred square feet of crawlspace area, or if the crawlspace vents are equipped with operable louvers, a radon vent shall be installed to originate from a point between the ground cover and soil. The radon vent shall be installed in accordance with sections 503.2.6 and 503.2.7.

502.1.3 Crawlspace Plenum Systems: In crawlspace plenum systems used for providing supply air for an HVAC system, aggregate, a permanently sealed soil gas retarder membrane and a radon vent pipe shall be installed in accordance with section 503.2. Crawlspaces shall not be used for return air plenums.

In addition, an operable radon vent fan shall be installed. The fan shall be located as specified in section 503.2.7. The fan shall be capable of providing at least one hundred cfm at one inch water column static pressure. The fan shall be controlled by a readily accessible manual switch. The switch shall be labeled "RADON VENT FAN."

[Statutory Authority: RCW 19.27.190 and 19.27.020. 98-02-047, § 51-13-502, filed 1/5/98, effective 7/1/98. Statutory Authority: RCW 19.27.190. 95-

(2003 Ed.)

01-128, § 51-13-502, filed 12/21/94, effective 6/30/95. Statutory Authority: RCW 19.27.190(2) and 1992 c 132. 93-02-056, § 51-13-502, filed 1/6/93, effective 7/1/93. Statutory Authority: RCW 19.27.190. 91-12-045, § 51-13-502, filed 6/5/91, effective 7/1/91; 91-01-102, § 51-13-502, filed 12/18/90, effective 7/1/91.]

WAC 51-13-503 Radon prescriptive requirements.

503.1 Scope: This section applies to those counties specified in section 501.2.2. This section establishes prescriptive construction requirements for reducing the potential for radon entry into all Group R Occupancies, and for preparing the building for future mitigation if desired.

In all crawlspaces, except crawlspace plenums used for providing supply air for an HVAC system, a continuous air barrier shall be installed between the crawlspace area and the occupied area to limit air transport between the areas: If a wood sheet subfloor or other material is utilized as an air barrier, in addition to the requirements of section 502.1.6.2 of the Washington state energy code, all joints between sheets shall be sealed.

503.2 Floors in Contact with the Earth

503.2.1 General: Concrete slabs that are in direct contact with the building envelope shall comply with the requirements of this section.

EXCEPTION: Concrete slabs located under garages or other than Group R Occupancies need not comply with this chapter.

503.2.2 Aggregate: A layer of aggregate of four inch minimum thickness shall be placed beneath concrete slabs. The aggregate shall be continuous to the extent practical.

503.2.3 Gradation: Aggregate shall:

a) Comply with ASTM Standard C-33 Standard Specification for Concrete Aggregate and shall be size No. 8 or larger size aggregate as listed in Table 2, Grading Requirements for Coarse Aggregate; or

b) Meet the 1988 Washington State Department of Transportation specification 9-03.1 (3) "Coarse Aggregate for Portland Cement Concrete," or any equivalent successor standards. Aggregate size shall be of Grade 8 or larger as listed in section 9-03.1 (3) C, "Grading"; or

c) Be screened, washed pea gravel free of deleterious substances in a manner consistent with ASTM Standard C-33 with one hundred percent (100%) passing a one-half (1/2) inch sieve and less than five percent (5%) passing a No. 16 sieve. Sieve characteristics shall conform to those acceptable under ASTM Standard C-33.

EXCEPTION: Aggregate shall not be required if a substitute material or system, with sufficient load bearing characteristics, and having approved capability to provide equal or superior air flow, is installed.

503.2.4 Soil-Gas Retarder Membrane: A soil-gas retarder membrane, consisting of at least one layer of virgin polyethylene with a thickness of at least six mil, or equivalent flexible sheet material, shall be either placed directly under all concrete slabs so that the slab is in direct contact with the membrane, or on top of the aggregate with two inches (2") minimum of fine sand or pea gravel installed between the

concrete slab and membrane. The flexible sheet shall extend to the foundation wall or to the outside edge of the monolithic slab. Seams shall overlap at least twelve inches. The membrane shall also be fitted tightly to all pipes, wires, and other penetrations of the membrane and sealed with an approved sealant or tape. All punctures or tears shall be repaired with the same or approved material and similarly lapped and sealed.

503.2.5 Sealing of Penetrations and Joints: All penetrations and joints in concrete slabs or other floor systems and walls below grade shall be sealed by an approved sealant to create an air barrier to limit the movement of soil-gas into the indoor air.

Sealants shall be approved by the manufacturer for the intended purpose. Sealant joints shall conform to manufacturer's specifications. The sealant shall be placed and tooled in accordance with manufacturer's specifications. There shall be no gaps or voids after the sealant has cured.

503.2.6 Radon Vent: One continuous sealed pipe shall run from a point within the aggregate under each concrete slab to a point outside the building. Joints and connections shall be permanently gas tight. The continuous sealed pipe shall interface with the aggregate in the following manner, or by other approved equal method: The pipe shall be permanently connected to a "T" within the aggregate area so that the two end openings of the "T" lie within the aggregate area. A minimum of five feet of perforated drain pipe of three inches minimum diameter shall join to and extend from the "T."

The perforated pipe shall remain in the aggregate area and shall not be capped at the ends. The "T" and its perforated pipe extensions shall be located at least five feet horizontally from the exterior perimeter of the aggregate area.

The continuous sealed pipe shall terminate no less than twelve inches above the eave, and more than ten horizontal feet from a woodstove or fireplace chimney, or operable window. The continuous sealed pipe shall be labeled "radon vent." The label shall be placed so as to remain visible to an occupant.

The minimum pipe diameter shall be three inches unless otherwise approved. Acceptable sealed plastic pipe shall be smooth walled, and may include either PVC schedule 40 or ABS schedule of equivalent wall thickness.

The entire sealed pipe system shall be sloped to drain to the sub-slab aggregate.

The sealed pipe system may pass through an unconditioned attic before exiting the building; but to the extent practicable, the sealed pipe shall be located inside the thermal envelope of the building in order to enhance passive stack venting.

EXCEPTION: A fan forced sub-slab depressurization system includes:

- 1) Soil-gas retarder membrane as specified in section 503.2.4;
- 2) Sealing of penetrations and joints as specified in section 503.2.5;
- 3) A three-inch continuous sealed radon pipe shall run from a point within the aggregate under each concrete slab to a point outside the building;

- 4) Joints and connections may be gas tight, and may be of either PVC schedule 40 or ABS schedule of equivalent in wall thickness;
- 5) A label of "radon vent" shall be placed on the pipe so as to remain visible to the occupant;
- 6) Fan circuit and wiring as specified in section 503.2.7 and a fan.

If the sub-slab depressurization system is exhausted through the concrete foundation wall or rim joist, the exhaust terminus shall be a minimum of six feet from operable windows or outdoor air intake vents and shall be directed away from operable windows and outdoor air intake vents to prevent radon re-entrainment.

503.2.7 Fan Circuit and Wiring and Location: An area for location of an in-line fan shall be provided. The location shall be as close as practicable to the radon vent pipe's point of exit from the building, or shall be outside the building shell; and shall be located so that the fan and all downstream piping is isolated from the indoor air.

Provisions shall be made to allow future activation of an in-line fan on the radon vent pipe without the need to place new wiring. A one hundred ten volt power supply shall be provided at a junction box near the fan location.

503.2.8 Separate Aggregate Areas: If the four-inch aggregate area underneath the concrete slab is not continuous, but is separated into distinct isolated aggregate areas by a footing or other barrier, a minimum of one radon vent pipe shall be installed into each separate aggregate area.

EXCEPTION: Separate aggregate areas may be considered a single area if a minimum three-inch diameter connection joining the separate areas is provided for every thirty feet of barrier separating those areas.

503.2.9 Concrete Block Walls: Concrete block walls connected to below grade areas shall be considered unsealed surfaces. All openings in concrete block walls that will not remain accessible upon completion of the building shall be sealed at both vertical and horizontal surfaces, in order to create a continuous air barrier to limit the transport of soil-gas into the indoor air.

[Statutory Authority: RCW 19.27.190, 19.27.020, 01-02-099, § 51-13-503, filed 1/3/01, effective 7/1/01. Statutory Authority: RCW 19.27.190(2) and 1992 c 132, 93-02-056, § 51-13-503, filed 1/6/93, effective 7/1/93. Statutory Authority: RCW 19.27.190, 91-01-102, § 51-13-503, filed 12/18/90, effective 7/1/91.]

Chapter 51-16 WAC

STATE BUILDING CODE GUIDELINES

WAC

51-16-010	Authority.
51-16-020	Purpose.
51-16-030	Exemptions for indigent housing guidelines.
51-16-080	Permit exemptions guideline.

DISPOSITION OF SECTIONS FORMERLY CODIFIED IN THIS CHAPTER

51-16-040	Uniform Mechanical Code. [Statutory Authority: RCW 19.27.074, 88-24-018 (Order 88-11), § 51-16-040, filed 12/1/88, effective 7/1/89. Statutory Authority: 1985 c 360, 85-24-029 (Order 85-13), § 51-16-040, filed 11/26/85, effective 6/11/86.] Repealed by 92-01-069, filed 12/13/91, effective 7/1/92. Statutory Authority: RCW 19.27.074, chapter 19.27 RCW and 1991 c 139.
-----------	--

- 51-16-050 Uniform Fire Code and Uniform Fire Code Standards. [Statutory Authority: Chapters 19.27, 19.27A and 70.92 RCW, and 1989 c 266, 90-02-110, § 51-16-050, filed 1/3/90, effective 7/1/90. Statutory Authority: RCW 19.27.074, 88-24-018 and 89-11-081 (Orders 88-11 and 88-11A), § 51-16-050, filed 12/1/88 and 5/23/89, effective 7/1/89. Statutory Authority: 1985 c 360, 85-24-029 (Order 85-13), § 51-16-050, filed 11/26/85, effective 6/11/86.] Repealed by 92-01-069, filed 12/13/91, effective 7/1/92. Statutory Authority: RCW 19.27.074, chapter 19.27 RCW and 1991 c 139.
- 51-16-060 Uniform Plumbing Code and Uniform Plumbing Code standards. [Statutory Authority: RCW 19.27.074, 88-24-018 (Order 88-11), § 51-16-060, filed 12/1/88, effective 7/1/89; 86-24-041 (Order 86-19), § 51-16-060, filed 11/26/86, effective 4/27/87. Statutory Authority: 1985 c 360, 85-24-029 (Order 85-13), § 51-16-060, filed 11/26/85, effective 6/11/86.] Repealed by 92-01-069, filed 12/13/91, effective 7/1/92. Statutory Authority: RCW 19.27.074, chapter 19.27 RCW and 1991 c 139.
- 51-16-070 Exceptions. [Statutory Authority: RCW 19.27.074, 88-24-018 (Order 88-11), § 51-16-070, filed 12/1/88, effective 7/1/89. Statutory Authority: 1985 c 360, 85-24-029 (Order 85-13), § 51-16-070, filed 11/26/85, effective 6/11/86.] Repealed by 92-01-069, filed 12/13/91, effective 7/1/92. Statutory Authority: RCW 19.27.074, chapter 19.27 RCW and 1991 c 139.
- 51-16-090 Submittal of proposed city or county amendments. [Statutory Authority: RCW 19.27.074, 88-24-018 (Order 88-11), § 51-16-090, filed 12/1/88, effective 7/1/89. Statutory Authority: 1985 c 360, 85-24-029 (Order 85-13), § 51-16-090, filed 11/26/85, effective 6/11/86.] Repealed by 90-13-033, filed 6/13/90, effective 7/23/90. Statutory Authority: RCW 19.27.060 (7)(b).
- 51-16-100 Review of city and county amendments previously approved by the council. [Statutory Authority: RCW 19.27.074, 88-24-018 (Order 88-11), § 51-16-100, filed 12/1/88, effective 7/1/89.] Repealed by 92-01-069, filed 12/13/91, effective 7/1/92. Statutory Authority: RCW 19.27.074, chapter 19.27 RCW and 1991 c 139.

WAC 51-16-010 Authority. These guidelines are adopted under the authority of chapter 19.27 RCW.

[Statutory Authority: RCW 19.27.074, chapter 19.27 RCW and 1991 c 139, 92-01-069, § 51-16-010, filed 12/13/91, effective 7/1/92. Statutory Authority: RCW 19.27.074, 88-24-018 (Order 88-11), § 51-16-010, filed 12/1/88, effective 7/1/89. Statutory Authority: 1985 c 360, 85-24-029 (Order 85-13), § 51-16-010, filed 11/26/85, effective 6/11/86.]

WAC 51-16-020 Purpose. The purpose of these guidelines is to provide local governments with amendatory language for specific applications. The guidelines are not required to be adopted and enforced by local governments.

[Statutory Authority: RCW 19.27.074, chapter 19.27 RCW and 1991 c 139, 92-01-069, § 51-16-020, filed 12/13/91, effective 7/1/92. Statutory Authority: RCW 19.27.074, 88-24-018 (Order 88-11), § 51-16-020, filed 12/1/88, effective 7/1/89. Statutory Authority: 1985 c 360, 85-24-029 (Order 85-13), § 51-16-020, filed 11/26/85, effective 6/11/86.]

WAC 51-16-030 Exemptions for indigent housing guidelines. Cities and counties are permitted the option of adopting exemptions from the state building code requirements for buildings whose character of use or occupancy has been changed in order to provide housing for indigent persons. The adoption of an ordinance or resolution by cities and counties for the purpose to provide for occupancy exemptions for indigent housing as outlined in this section, shall not be considered a local government residential amendment requiring approval by the state building code council.

The guideline shall read as follows:

(2003 Ed.)

The character of use or occupancy of an existing building located in this state, may be changed in order to provide housing for indigent persons, without conforming to all of the requirements of the State Building Code provided that:

1. The building official has reviewed and approved the proposed exemption; and,
2. The proposed housing for indigent persons is less hazardous than the existing use; and,
3. Any code deficiencies exempted pose no threat to human life, health, or safety; and,
4. The building or buildings exempted are owned or administered by a public agency or nonprofit corporation; and,
5. The exemption is authorized for no more than five years, subject to renewal of the exemption by the building official.

[Statutory Authority: RCW 19.27.074, chapter 19.27 RCW and 1991 c 139, 92-01-069, § 51-16-030, filed 12/13/91, effective 7/1/92. Statutory Authority: RCW 19.27.020 and 19.27.074, 91-01-117, § 51-16-030, filed 12/19/90, effective 7/1/91. Statutory Authority: Chapters 19.27, 19.27A and 70.92 RCW, and 1989 c 266, 90-02-110, § 51-16-030, filed 1/3/90, effective 7/1/90. Statutory Authority: RCW 19.27.074, 88-24-018 and 89-11-081 (Orders 88-11 and 88-11A), § 51-16-030, filed 12/1/88 and 5/23/89, effective 7/1/89. Statutory Authority: 1985 c 360, 85-24-029 (Order 85-13), § 51-16-030, filed 11/26/85, effective 6/11/86.]

WAC 51-16-080 Permit exemptions guideline. Cities and counties are permitted the option of adopting a one thousand five hundred dollar building permit exemption for certain construction and alteration activities for Group R, Division 3 and Group M, Division 1 Occupancies. To adopt the permit exemption guideline, the following section of the 1991 Uniform Building Code shall be amended as follows:

(1) Section 301(b) of the Uniform Building Code shall be amended to read as follows:

(b) Exempted work. A building permit shall not be required for the following:

1. One-story detached accessory buildings used as tool and storage sheds, playhouses and similar uses, provided the projected roof area does not exceed one hundred twenty square feet.
2. Fences not over six feet high.
3. Oil derricks.
4. Movable cases, counters, and partitions not over five feet nine inches high.
5. Retaining walls which are not over four feet in height measured from the bottom of the footing to the top of the wall, unless supporting a surcharge or impounding Class I, II, or III-A liquids.
6. Water tanks supported directly upon grade if the capacity does not exceed five thousand gallons and the ratio of height to diameter or width does not exceed two to one.
7. Platforms, walks, and driveways not more than thirty inches above grade and not over any basement or story below.
8. Painting, papering, and similar finish work.
9. Temporary motion picture, television, and theater stage sets and scenery.
10. Window awnings supported by an exterior wall of Group R, Division 3, and Group M Occupancies when projecting not more than fifty-four inches.

11. Prefabricated swimming pools accessory to a Group R, Division 3 Occupancy in which the pool walls are entirely above the adjacent grade and if the capacity does not exceed five thousand gallons.

12. Minor construction and alteration activities to Group R, Division 3 and Group M, Division 1 Occupancies, as determined by the building official, which the total valuation, as determined in Section 304(b) or as documented by the applicant to the satisfaction of the building official, does not exceed one thousand five hundred dollars in any twelve-month period: Provided, That the construction and/or alteration activity does not affect any structural components, or reduce existing egress, light, air, and ventilation conditions. This exemption does not include electrical, plumbing, or mechanical activities. The permit exemption shall not otherwise exempt the construction or alteration from the substantive standards of the codes enumerated in RCW 19.27.031, as amended and maintained by the state building code council under RCW 19.27.070.

Unless otherwise exempted, separate plumbing, electrical, and mechanical permits will be required for the above exempted items.

Exemption from the permit requirements of this code shall not be deemed to grant authorization for any work to be done in any manner in violation of the provisions of this code or any other laws or ordinances of this jurisdiction.

The adoption of an ordinance or resolution by cities and counties for the purpose to provide for a permit exemption as outlined in this section, shall not be considered a local government residential amendment requiring approval by the state building code council.

[Statutory Authority: RCW 19.27.074, chapter 19.27 RCW and 1991 c 139, 92-01-069, § 51-16-080, filed 12/13/91, effective 7/1/92. Statutory Authority: RCW 19.27.060 (7)(b), 90-13-033, § 51-16-080, filed 6/13/90, effective 7/23/90. Statutory Authority: RCW 19.27.074, 88-24-018 (Order 88-11), § 51-16-080, filed 12/1/88, effective 7/1/89. Statutory Authority: 1985 c 360, 85-24-029 (Order 85-13), § 51-16-080, filed 11/26/85, effective 6/1/86.]

Chapter 51-19 WAC

WASHINGTON STATE HISTORIC BUILDING CODE WAC

**PART I
TITLE AND SCOPE**

- 51-19-100 Title.
- 51-19-110 Purpose.
- 51-19-120 Scope.
- 51-19-130 Existing uses.
- 51-19-140 Additions, alterations, and repairs.
- 51-19-150 Change of occupancy.
- 51-19-160 Maintenance.
- 51-19-170 Alternative materials, designs, and methods.
- 51-19-180 Modifications.
- 51-19-190 Tests.

**PART II
ADMINISTRATION**

- 51-19-200 Enforcement.
- 51-19-210 Permits.
- 51-19-220 Inspection.
- 51-19-230 Repairs.
- 51-19-240 Relocated buildings.
- 51-19-250 Right of entry.
- 51-19-260 Liability.
- 51-19-270 Unsafe buildings or structures.
- 51-19-280 Appeals.

**PART III
DEFINITIONS**

- 51-19-300 Definitions.

**PART IV
FIRE AND LIFE SAFETY STANDARDS**

- 51-19-400 General.
- 51-19-410 Exit systems.
- 51-19-420 Structural safety.
- 51-19-430 Weather protection.
- 51-19-440 Other safety features.
- 51-19-450 Light, ventilation, sanitation, smoke detectors, and heating.
- 51-19-460 Plumbing.

**PART V
EARTHQUAKE HAZARD REDUCTION**

- 51-19-500 Survey or evaluation.
- 51-19-510 Alternatives.

**PART VI
CHANGE OF OCCUPANCY STANDARDS**

- 51-19-600 General.
- 51-19-610 Heights and area.
- 51-19-620 Fire safety.
- 51-19-630 Property protection.
- 51-19-640 Structural safety.
- 51-19-650 Light and ventilation.
- 51-19-660 Flame spread reduction.
- 51-19-670 Roof coverings.

**PART VII
ACCESSIBILITY TO PERSONS WITH DISABILITIES**

- 51-19-700 General.
- 51-19-710 Building access and use.

**PART VIII
ENERGY CONSERVATION**

- 51-19-800 General.
- 51-19-810 Alternative energy conservation provisions.

PART IX APPENDICES

- 51-19-900 Appendix A.
- 51-19-901 Appendix B—Bibliography.

**PART I
TITLE AND SCOPE**

WAC 51-19-100 Title. This code shall be known as the Washington State Historic Building Code, hereinafter referred to as the HBC.

[Statutory Authority: RCW 19.27.120 and 19.27.074, 91-01-103, § 51-19-100, filed 12/18/90, effective 7/1/91.]

WAC 51-19-110 Purpose. It is the purpose of the HBC to provide regulations, as prescribed in RCW 19.27.120(2), providing alternatives, when authorized by the appropriate building official, to conformance to all the requirements of the codes adopted under RCW 19.27.031, for repairs, alterations, and additions necessary for the preservation, restoration and related reconstruction, rehabilitation, strengthening, or relocation of buildings or structures designated as historic buildings, in accordance with RCW 19.27.120(1). Such regulations are intended to preserve original, or restored architectural elements and features, to encourage energy conservation, barrier-free access and a cost-effective approach to preservation, and to provide a historic building or structure that will be less hazardous, based on accepted life and fire safety practices, than the existing building. These regulations, when authorized by the appropriate building official, control and

allow alternatives to any and all codes enumerated in RCW 19.27.031 when dealing with historic buildings or sites.

The purpose of this code is not to create or otherwise establish or designate any particular class or group of persons who will or should be especially protected or benefited by the terms of this code.

[Statutory Authority: RCW 19.27.120 and 19.27.074. 91-01-103, § 51-19-110, filed 12/18/90, effective 7/1/91.]

WAC 51-19-120 Scope. The provisions of the HBC shall constitute the minimum standards for the preservation, restoration and related reconstruction, rehabilitation, strengthening, or relocation of buildings or structures, changes of occupancy and alteration or repair of historic buildings. Whenever reference is made to an appendix in this code, the provisions of the appendix shall not apply unless specifically adopted.

[Statutory Authority: RCW 19.27.120 and 19.27.074. 91-01-103, § 51-19-120, filed 12/18/90, effective 7/1/91.]

WAC 51-19-130 Existing uses. Historic buildings may have their existing use or occupancy continued if such use or occupancy was legal at the time of the adoption of the HBC, provided such continued use is not dangerous to life and that subsequently adopted regulations specifically applicable to historic buildings or structures are satisfied.

Nothing in the HBC shall be construed to allow the degradation of those systems, devices and equipment required by the prevailing codes under which the building was constructed.

[Statutory Authority: RCW 19.27.120 and 19.27.074. 91-01-103, § 51-19-130, filed 12/18/90, effective 7/1/91.]

WAC 51-19-140 Additions, alterations, and repairs. Buildings and structures to which additions, alterations, or repairs are made shall comply with all the requirements of the Building Code for new construction except as specifically provided in the HBC. Additions, alterations, or repairs may be made to any building or structure without requiring the historic building or structure to comply with all the requirements of the Building Code, provided:

- (1) Additions shall conform to the requirements for a new building or structure.
- (2) Additions, alterations, or repairs shall not cause a historic building or structure to become unsafe or overloaded.
- (3) New additions shall not add to or cause a historic building to exceed the height, number of stories, or area specified for new buildings.

[Statutory Authority: RCW 19.27.120 and 19.27.074. 91-01-103, § 51-19-140, filed 12/18/90, effective 7/1/91.]

WAC 51-19-150 Change of occupancy. Any change in the use or occupancy of a historic building or structure shall comply with the provisions of the HBC. Any building which involves a change in use or occupancy shall not exceed the height, number of stories, and area permitted for new buildings, except as permitted in the HBC and local ordinances.

[Statutory Authority: RCW 19.27.120 and 19.27.074. 91-01-103, § 51-19-150, filed 12/18/90, effective 7/1/91.]

(2003 Ed.)

WAC 51-19-160 Maintenance. All buildings and structures and all parts thereof shall be maintained in a safe and sanitary condition. All systems, devices, or safeguards which were required by the prevailing codes under which the building was constructed shall be maintained in conformance with the requirements of the HBC. The owner or the owner's designated agent shall be responsible for the maintenance of buildings and structures. To determine compliance with this section, the building official may cause any structure to be reinspected.

[Statutory Authority: RCW 19.27.120 and 19.27.074. 91-01-103, § 51-19-160, filed 12/18/90, effective 7/1/91.]

WAC 51-19-170 Alternative materials, designs, and methods. The provisions of this code are not intended to prevent the use of any material, design, or method of construction not specifically prescribed by the HBC, provided any alternate has been approved and its use authorized by the building official.

The building official may approve any such alternate, provided the building official finds that the proposed design is satisfactory and complies with the provisions of the HBC and that the material and method of work offered is, for the purpose intended, at least the equivalent of that prescribed in this code in suitability, strength, effectiveness, fire resistance, durability, safety, and sanitation.

The building official shall require that sufficient evidence or proof be submitted to substantiate any claims that may be made regarding use of an alternate. The details of any action granting approval of an alternate shall be recorded and entered in the files of the code enforcement agency.

[Statutory Authority: RCW 19.27.120 and 19.27.074. 91-01-103, § 51-19-170, filed 12/18/90, effective 7/1/91.]

WAC 51-19-180 Modifications. Whenever there are practical difficulties involved in carrying out the provisions of the HBC, the building official may accept compliance alternatives or grant modifications for individual cases, provided the building official shall first find that a significant reason makes the strict letter of the HBC impractical and that the compliance alternative or modification is in conformity with the intent and purpose of the HBC and that such compliance alternative or modification does not lessen health, life-safety, and the intent of any fire-safety requirements or any degree of structural integrity. The details of any action granting modifications or the acceptance of a compliance alternative shall be recorded and entered in the files of the code enforcement agency.

[Statutory Authority: RCW 19.27.120 and 19.27.074. 91-01-103, § 51-19-180, filed 12/18/90, effective 7/1/91.]

WAC 51-19-190 Tests. Whenever there is insufficient evidence of compliance with any of the provisions of the HBC or evidence that any material or construction does not conform to the requirements of the HBC, the building official may require tests as proof of compliance to be made at no expense to the jurisdiction.

Test methods shall be as specified by the HBC, the Building Code, or by other recognized test standards. If there are no recognized and accepted test methods for the proposed

alternate, the building official shall determine test procedures.

All tests shall be made by an approved agency. Reports of such tests shall be retained by the building official for the period required for the retention of public records.

[Statutory Authority: RCW 19.27.120 and 19.27.074. 91-01-103, § 51-19-190, filed 12/18/90, effective 7/1/91.]

PART II ADMINISTRATION

WAC 51-19-200 Enforcement. The building official is hereby authorized to enforce the provisions of the HBC. The building official shall have the power to render interpretations of the HBC and to adopt and enforce rules and regulations supplemental to this code as may be deemed necessary in order to clarify the application of the provisions of the HBC. Such interpretations, rules, and regulations shall be in conformity with the intent and purpose of the HBC.

[Statutory Authority: RCW 19.27.120 and 19.27.074. 91-01-103, § 51-19-200, filed 12/18/90, effective 7/1/91.]

WAC 51-19-210 Permits. Buildings or structures regulated by the HBC shall not be enlarged, altered, repaired, improved, or converted unless a separate permit for each building or structure has been obtained from the building official in accordance with and in the manner prescribed in the Building Code.

[Statutory Authority: RCW 19.27.120 and 19.27.074. 91-01-103, § 51-19-210, filed 12/18/90, effective 7/1/91.]

WAC 51-19-220 Inspection. All buildings or structures within the scope of this code and all construction or work for which a permit is required shall be subject to inspection by the building official in accordance with and in the manner prescribed in the HBC and the Building Code.

[Statutory Authority: RCW 19.27.120 and 19.27.074. 91-01-103, § 51-19-220, filed 12/18/90, effective 7/1/91.]

WAC 51-19-230 Repairs. Repairs to any portion of a historic building or structure may be made with original materials and original methods of construction, subject to provisions of the HBC.

[Statutory Authority: RCW 19.27.120 and 19.27.074. 91-01-103, § 51-19-230, filed 12/18/90, effective 7/1/91.]

WAC 51-19-240 Relocated buildings. Relocated historic buildings shall be considered a historic building for the purposes of the HBC. Relocated residential buildings in or within a county or city are not required to meet the full requirements of the Building Code, as prescribed in RCW 19.27.180, provided the occupancy classification of the building or structure is not changed as a result of the move. If an occupancy classification change occurs as a result of the move, the building or structure shall be reviewed under Part VI, Change of occupancy standards. Relocated historic buildings and structures shall be so sited that exterior wall and opening requirements comply with the Building Code or the compliance alternatives of the HBC. Foundations of relo-

[Title 51 WAC—p. 126]

ated historic buildings and structures shall comply with the Building Code.

[Statutory Authority: RCW 19.27.120 and 19.27.074. 91-01-103, § 51-19-240, filed 12/18/90, effective 7/1/91.]

WAC 51-19-250 Right of entry. Whenever necessary to make an inspection to enforce any of the provisions of the HBC, or whenever the building official or an authorized representative has reasonable cause to believe that there exists in any building or upon any premises any condition or code violation which makes such building or premises unsafe, dangerous or hazardous, the building official or an authorized representative may enter such building or premises at all reasonable times to inspect the same or to perform any duty imposed upon the building official by the HBC, provided that if such building or premises be occupied, proper credentials shall first be presented and entry requested; and if such building or premises be unoccupied, the official shall first make a reasonable effort to locate the owner or other persons having charge or control of the building or premises and request entry. If such entry is refused, the building official or an authorized representative shall have recourse to every remedy provided by law to secure entry.

[Statutory Authority: RCW 19.27.120 and 19.27.074. 91-01-103, § 51-19-250, filed 12/18/90, effective 7/1/91.]

WAC 51-19-260 Liability. The building official or an authorized representative charged with the enforcement of the HBC, acting in good faith and without malice in the discharge of the prescribed duties, shall not thereby render themselves liable for any damage that may accrue to persons or property as a result of any act or by reason of any act or omission in the discharge of those duties. Any suit brought against the building official or employee because of such act or omission performed in the enforcement of any provision of the HBC shall be defended by the jurisdiction until final termination of such proceedings and any judgment resulting therefrom shall be assumed by the jurisdiction.

The HBC shall not be construed to relieve from or lessen the responsibility of any person owning, operating, or controlling any building or structure for any damages to persons or property caused by defects, nor shall the code enforcement agency or its parent jurisdiction be held as assuming any such liability by reason of the inspections authorized by the HBC or any permits or certificates issued under the HBC.

[Statutory Authority: RCW 19.27.120 and 19.27.074. 91-01-103, § 51-19-260, filed 12/18/90, effective 7/1/91.]

WAC 51-19-270 Unsafe buildings or structures. All buildings or structures regulated by the HBC which are structurally unsafe or not provided with adequate egress, or which constitute a fire hazard or are otherwise dangerous to human life are, for the purpose of this section, unsafe. Unsafe buildings shall comply with section 203 of the Building Code.

[Statutory Authority: RCW 19.27.120 and 19.27.074. 91-01-103, § 51-19-270, filed 12/18/90, effective 7/1/91.]

WAC 51-19-280 Appeals. The board of appeals established under the Building Code shall have authority to pro-

vide for final interpretation of the provision of the HBC and to hear appeals.

[Statutory Authority: RCW 19.27.120 and 19.27.074. 91-01-103, § 51-19-280, filed 12/18/90, effective 7/1/91.]

PART III DEFINITIONS

WAC 51-19-300 Definitions. For the purpose of the HBC, certain terms, phrases, words, and their derivatives shall be construed as specified in this chapter. Words used in the singular include the plural and the plural the singular. Words used in the masculine gender include the feminine and the feminine the masculine.

Where terms are not defined, they shall have their ordinary accepted meanings within the context in which they are used. In the event there is a question about the definition of a term, the definitions for terms in the codes enumerated in RCW 19.27.031 and the edition of *Webster's Dictionary*, referenced therein shall be considered as the sources for providing ordinarily accepted meanings.

"Adaptive use" is the process of adapting a building to accomplish a use other than that for which it was designed; i.e., a piano factory being converted into housing, or a mansion into an office or apartments.

"Addition" is an extension or increase in floor area or height of a building or structure.

"Alter or alteration" is any change, addition, or modification in construction or occupancy.

"Approved agency" is an established and recognized agency regularly engaged in conducting tests or furnishing inspection services, when such agency has been approved by the building official.

"Building" is any structure used or intended for supporting or sheltering any use or occupancy. (See structure.)

"Building Code" is the Uniform Building Code, promulgated by the International Conference of Building Officials as adopted by the state building code council.

"Building official" is the officer or other designated authority charged with the administration and enforcement of the HBC, or a duly authorized representative.

"Building service equipment" refers to the plumbing, mechanical, electrical, and elevator equipment including piping, wiring, fixtures, and other accessories which provide sanitation, lighting, heating, ventilation, cooling, refrigeration, firefighting, and transportation facilities essential for the habitable occupancy of the building or structure for its designated use and occupancy.

"Certified local government" or "CLG" means the local government has been certified by the state historic preservation officer as having established its own historic preservation commission and a program meeting federal and state standards.

"Dangerous Building Code" is the code, adopted by this jurisdiction, which outlines the processes and procedures for the determination and abatement of dangerous buildings.

"Electrical Code" is the National Electrical Code, promulgated by the National Fire Protection Association, as adopted by the Washington state department of labor and industries, electrical section.

"Equivalency" is meeting the intent of the HBC by means other than those detailed in specific code provisions.

"Fire hazard" is any thing or act which increases or may cause an increase of the hazard or menace of fire to a greater degree than that customarily recognized as normal by persons in the public service regularly engaged in preventing, suppressing, or extinguishing fire; or which may obstruct, delay, hinder, or interfere with the operations of the fire department or the egress of occupants in the event of fire.

"Historic building" is any structure, collection of structures, and their associated sites, deemed of importance to the history, architecture, or culture of an area by an appropriate local, state, or federal governmental jurisdiction. Included shall be structures on official national, state, or local historic registers or official listings such as the National Register of Historic Places, the state register of historic places, state points of historical interest, and registers or listings of historical or architecturally significant sites, places, historic districts, or landmarks as adopted by a certified local government.

"Historic fabric" consists of the original materials and portions of the building intact when exposed or as they appeared and were used in the past.

"Historical aspects" are the particular features of the historic site, building, or structure that gives it its historic significance. Features may include but are not limited to one or more of the following: Historical background, noteworthy architecture, unique design, works of art, memorabilia, and artifacts.

"Imminent hazard" is a condition which could cause serious or life threatening injury or death at any time.

"Occupancy" is the purpose for which a building, or part thereof, is used or intended to be used.

"Original materials" are those portions of the structure's fabric that existed during the period deemed to be most architecturally and/or historically significant.

"Preservation" is the maintenance of the structure in its present condition or as originally constructed. Preservation aims at halting further deterioration and providing structural safety, but does not contemplate significant rebuilding. Preservation includes techniques of arresting or slowing the deterioration of a structure; improvement of structural conditions to make a structure safe, habitable, or otherwise useful; normal maintenance and minor repairs that do not change or adversely affect the fabric or appearance of a structure.

"Prevailing code" is the "regular building regulations" which governed the design and construction or alteration of historical buildings within the jurisdiction of the enforcing agency at the time of their construction.

"Reconstruction" is the process of rebuilding a nonextant structure or portion of a structure to its original appearance through archival and archeological investigation. Although parts of the original structure are sometimes included in the reconstruction, the process usually involves new construction materials.

"Rehabilitation" involves equipping the building or facility for an extended useful life with a minimum alteration of original construction or the process of returning a structure to a state of usefulness by repairs, alterations, or additions.

"Relocation" involves any structure or a portion of a structure that may be moved to a new location.

"Renovation" is to make sound again any structure involved under the various definitions hereunder by cleanup, repair, and replacement of deteriorated detail or structure.

"Repair" is the reconstruction, renovation, or renewal of any portion of a historic building for the purpose of its maintenance.

"Reproduction" is a duplication, copy, or close imitation of the original.

"Restoration" is the process of accurately recovering, by the removal of later work and the replacement of missing earlier work, the form and details of a structure, together with its setting, as it appeared at a particular period of time.

"Structure" is that which is built or constructed, an edifice or building of any kind, or any piece of work artificially built up or composed of parts joined together in some definite manner.

[Statutory Authority: RCW 19.27.120 and 19.27.074. 91-01-103, § 51-19-300, filed 12/18/90, effective 7/1/91.]

PART IV FIRE AND LIFE SAFETY STANDARDS

WAC 51-19-400 General. Safety to life in historic buildings and structures shall meet the intent of the Building Code. The provisions of this section shall be deemed as meeting the intent of the Historic Building Code, provided that none of the fire and life-safety features required by the prevailing codes under which the building was constructed will be reduced below the level established by either the HBC or the equivalent provisions of the currently adopted Building Code, whichever is least stringent. Alterations or repairs to a historic building or structure which are nonstructural and do not adversely affect any structural member or any part of the building or structure having required fire resistance may be made with the same materials of which the building or structure is constructed. Fire resistive ratings of archaic materials may be evaluated based upon the Guideline on Fire Ratings of Archaic Materials and Assemblies from Guideline 2 of the Uniform Code for Building Conservation.

[Statutory Authority: RCW 19.27.120 and 19.27.074. 91-01-103, § 51-19-400, filed 12/18/90, effective 7/1/91.]

WAC 51-19-410 Exit systems. (1) Exit system capacity and the arrangement of exits shall comply with the requirements of the Building Code. Exit systems shall comply with the provisions of subsections (1) through (5) of this section, or the provisions of the prevailing code under which the building was constructed, whichever is more stringent. If any provision of the HBC or the prevailing code under which a building was constructed is more stringent than the currently adopted Building Code, the exit system shall comply with the provision of the currently adopted Building Code.

(2) All elements of the exit system shall be of sufficient size, width, and arrangement to provide safe and adequate means of egress. Every required exit shall have access to a public way, directly or through yards, courts or similar spaces, and such access shall be permanently maintained clear of any obstruction which would impede exiting.

(3) Occupants of every floor above the first story and in basements shall have access to at least two separate exits. A fire escape shall not be substituted for a stairway which was required by the prevailing codes under which the building was constructed.

EXCEPTIONS:

- (a) In all occupancies, second stories with an occupant load of less than ten may have one exit.
- (b) Only one exit need be provided from the second story within an individual dwelling unit which has an occupant load of less than ten.
- (c) Two or more dwelling units on the second story may have access to only one common exit when the total occupant load does not exceed ten.
- (d) Floors and basements used exclusively for service of the building may have one exit. For the purposes of this exception, storage rooms, laundry rooms, maintenance offices, and similar uses shall not be considered as providing service to the building.
- (e) Basements within an individual dwelling unit having an occupant load of less than ten may have one exit.
- (f) Occupied roofs of Group R, Division 3 Occupancies may have one exit if such occupied areas are less than five hundred square feet and located no higher than immediately above the second story.

(4) Corridors serving as a part of the exit system which have an occupant load of thirty or more in a Group A, B, E, or H Occupancy or an occupant load of ten or more in a Group R, Division 1 or Group I Occupancy shall have walls and ceilings of not less than one hour fire resistive construction. Existing walls and ceilings surfaced with wood lath and plaster or one-half inch thick gypsum wallboard may be permitted in lieu of one hour fire resistive construction, provided the surfaces are in good condition.

Door openings into such corridors shall be protected by a tight fitting smoke and draft control assembly having a fire protection rating of not less than twenty minutes when such opening protection was required by the prevailing codes under which the building was constructed. Door closing devices, door gaskets, and other requirements imposed by the prevailing codes under which the building was constructed shall be maintained. When the building was constructed under a code which did not require twenty minute smoke and draft control assemblies, doorway openings shall be protected by doors having a fire protection rating of not less than twenty minutes or by a minimum one and three-eighths inch thick, solid bonded, wood core door or an equivalent insulated steel door. In such case, the frames need not have a fire resistive time period. Doors shall be maintained self-closing or shall be automatic closing, self-latching by activation of a smoke detector.

Transoms and openings other than doors from corridors to rooms shall be protected as required by the Building Code. Existing transoms may be maintained if fixed in the closed position. When the code under which the building was constructed permitted unprotected transoms or other unprotected openings, other than doors, such transoms or openings shall be covered with a minimum of three-fourths-inch-thick plywood, one-half-inch-thick gypsum wallboard, fixed glazing listed and labeled for a fire protection rating of at least three-fourths hour or equivalent material on the room side. Openings with fixed wired glass set in steel frames are permitted in corridor walls and ceilings.

EXCEPTION:

Existing corridor walls, ceilings, and opening protection not in compliance with the above may be contin-

ued when the building is protected with an approved automatic sprinkler system throughout: Provided, That a draft gasket assembly on sound, solid, self-closing, self-latching doors at door openings is installed and that sealing, caulking, and duct penetrations shall have dampers in all one-hour rated exit corridors. Such sprinkler system may be supplied from the domestic water supply system, provided the system is of adequate pressure, capacity, and sizing for the combined domestic and sprinkler requirements.

(5) Every dwelling unit, guest room, or sleeping rooms shall have access directly to the outside or to a public corridor or exit balcony.

(6) Existing fire escapes complying with this section may be accepted by the building official as one of the required exits. The fire escape shall not be the primary or the only exit. Fire escapes shall not take the place of stairways required by the codes under which the building was constructed.

Fire escapes shall comply with the following:

(a) Access from a corridor shall not be through an intervening room.

EXCEPTION: Access through an intervening room may be permitted if the intervening door is not lockable and an exit sign is installed above the door which will direct occupants to the fire escape.

(b) All openings in an exterior wall below or within ten feet, measured horizontally, of an existing fire escape serving a building over two stories in height shall be protected by fire assembly having a minimum three-fourths hour fire protection rating, and where operable be self-closing. When openings are located within a recess or vestibule, adjacent enclosure walls shall be of not less than one hour fire resistive construction.

(c) Egress from the building shall be by an opening having a minimum clear width and height of not less than twenty-nine inches. Such openings shall be openable from the inside without the use of a key or special knowledge or effort. The sill of an opening giving access to the fire escape shall be not more than thirty inches above the floor of the building or balcony.

(d) Fire escape stairways and their balconies shall support their dead load plus a live load of not less than one hundred pounds per square foot or concentrated load of three hundred pounds placed anywhere on the balcony or stairway so as to produce the maximum stress conditions. The stairway shall have a pitch not to exceed sixty degrees from the horizontal and shall have a minimum width of eighteen inches. The stairway shall be provided with a top and intermediate railing on each side. Treads shall be not less than four inches in width and the rise between treads shall not exceed ten inches. All stairway and balcony railings shall support a horizontally applied force of not less than fifty pounds per lineal foot of railing or a concentrated load of two hundred pounds placed anywhere on the railing so as to produce the maximum stress conditions.

(e) Fire escape balconies shall be not less than forty-four inches in width with no floor opening greater than five-eighths inch in width except the stairway opening. Stairway openings in such balconies shall be not less than twenty-two inches by forty-four inches. The guardrail of each balcony shall be not less than thirty-six inches high with not more than nine inches between intermediate rails.

(f) Fire escapes shall extend to the roof or provide an approved gooseneck ladder between the top floor landing and the roof when serving buildings four or more stories in height having roofs with a slope not exceeding four in twelve. Such ladders shall be designed and connected to the building to withstand a horizontal force of one hundred pounds per lineal foot; each rung shall support a concentrated load of five hundred pounds placed anywhere on the rung so as to produce the maximum stress conditions. All ladders shall be at least fifteen inches in clear width, be located within twelve inches of the building, and shall be placed flatwise relative to the face of the building. Ladder rungs shall be three-quarters inch in diameter and shall be located ten inches to twelve inches on center. Openings for roof access ladders through cornices and similar projections shall have minimum dimensions of thirty inches by thirty-three inches.

(g) The lowest balcony shall be not more than eighteen feet from the ground. Fire escapes shall extend to the ground or be provided with counterbalanced stairs reaching to the ground.

(h) Fire escapes shall be kept clear and unobstructed at all times and maintained in good working order.

(i) The fire escape shall have a clearance from electrical service conductors as required by the Electrical Code.

(7) Existing winding or spiral stairways may serve as one exit from a building, provided that a complying handrail is located at the stair's outside perimeter. (See WAC 51-19-440.) A winding or spiral stairway may not be the principal exit when used in conjunction with a fire escape as a second exit. The width of a spiral or winding stair may be used in the calculation of provided exit width when in compliance with this section. Circular stairways complying with the Building Code shall be acceptable as an exit.

[Statutory Authority: RCW 19.27.120 and 19.27.074. 91-01-103, § 51-19-410, filed 12/18/90, effective 7/1/91.]

WAC 51-19-420 Structural safety. A building or structure or its individual structural members that exceed the limits established by the Dangerous Buildings Code shall be replaced or strengthened in order that the building, structure, or individual structural members will comply with the requirements of the Building Code for new construction. Roofs, floors, walls, foundations, and all structural components of buildings or structures shall be capable of resisting the forces and loads for the occupancies intended, as specified in the prevailing codes under which the building was constructed or in chapter 23 of the Building Code, except for earthquake forces and loads. See Part V of this chapter for earthquake hazard reduction requirements.

[Statutory Authority: RCW 19.27.120 and 19.27.074. 91-01-103, § 51-19-420, filed 12/18/90, effective 7/1/91.]

WAC 51-19-430 Weather protection. (1) Every building shall provide weather protected shelter for the occupants against the elements and exclude dampness.

(2) The roof of every building or structure shall provide weather protection for the building. All devices which were provided or are required to prevent ponding or flooding or to convey the roof water shall be capable of fulfilling that purpose.

(3) All weather exposed surfaces of historic buildings or structures shall provide weather protection.

[Statutory Authority: RCW 19.27.120 and 19.27.074. 91-01-103, § 51-19-430, filed 12/18/90, effective 7/1/91.]

WAC 51-19-440 Other safety features. (1)(a) The largest tread run within any flight of stairs shall not exceed the smallest by more than three-eighths inch. The greatest riser height within any flight of stairs shall not exceed the smallest by more than three-eighths inch.

EXCEPTION: Existing spiral and circular stairs shall be exempt from the variance in tread size requirement.

(b) Every stairway shall have at least one handrail.

EXCEPTION: A handrail is not required for existing stairs having less than four risers.

Spiral and winding stairways shall have a handrail on the outside perimeter.

(2) All unenclosed floor and roof openings, open and glazed sides of stairways, landings and ramps, balconies or porches which are more than thirty inches above grade or floor below, and roofs used for other than service of the building shall be protected by a guardrail.

EXCEPTION: Guardrails need not be provided at the following locations:

- (a) On the loading side of loading docks.
- (b) On the auditorium side of a stage or enclosed platform.
- (c) On private stairways thirty inches or less in height.

Existing guardrails, other than guardrails located on the open side of a stairway, which are at least thirty-six inches in height shall be permitted to remain. Guardrails lower than thirty-six inches in height shall be augmented or corrected to raise their effective height to thirty-six inches. Guardrails for stairways, exclusive of their landings, may have a height which is not less than thirty inches measured above the nosing of treads.

The spacing between existing intermediate railings or openings in existing ornamental patterns in significant historical staircases may be accepted; otherwise the Building Code shall apply. Missing elements or members of a guardrail may be replaced in a manner which will preserve the historic appearance of the building or structure.

(3) The installation or replacement of glass shall be as required for new construction by the Building Code and the requirements for energy conservation in Part VIII of this code.

(4) All wires and equipment, and installations thereof, that convey electric current, in, on, or about buildings or structures shall be in strict conformity with chapter 19.28 RCW, the statutes of the state of Washington, and the rules issued by the Washington state department of labor and industries.

(5) Leaking drain or supply lines shall be repaired or replaced. All unsafe conditions shall be corrected. Any cross connections or siphonage between fixtures shall be corrected.

(6) Mechanical systems shall have any unsafe conditions corrected.

[Statutory Authority: RCW 19.27.120 and 19.27.074. 91-01-103, § 51-19-440, filed 12/18/90, effective 7/1/91.]

[Title 51 WAC—p. 130]

WAC 51-19-450 Light, ventilation, sanitation, smoke detectors, and heating. (1) For Group R Occupancies, light, ventilation, sanitation, smoke detectors, and heating shall meet the requirements of the Building Code.

(2) Skylights set at an angle of less than forty-five degrees from the horizontal plane shall be mounted at least four inches above the plane of the roof on a curb constructed of materials as required for the frame. Skylights may be installed in the plane of the roof when the roof slope is greater than forty-five degrees from horizontal.

[Statutory Authority: RCW 19.27.120 and 19.27.074. 91-01-103, § 51-19-450, filed 12/18/90, effective 7/1/91.]

WAC 51-19-460 Plumbing. All plumbing fixtures shall be connected to a sanitary sewer or to an approved private sewage disposal system. All plumbing fixtures shall be connected to an approved system of water supply and provided with hot and cold running water necessary for its normal operation. All plumbing fixtures shall be of an approved glazed earthenware type or of a similarly nonabsorbent material.

[Statutory Authority: RCW 19.27.120 and 19.27.074. 91-01-103, § 51-19-460, filed 12/18/90, effective 7/1/91.]

PART V EARTHQUAKE HAZARD REDUCTION

WAC 51-19-500 Survey or evaluation. When required by the building official a survey or evaluation shall be made by an architect or structural engineer licensed by the state to practice as such, who is knowledgeable in the earthquake resistant design of structures, regarding the structure's ability to resist the seismic loads prescribed by the Building Code requirements or by established alternate evaluation methodologies. Broad judgment may be exercised concerning the strength and performance of materials not recognized by the Building Code. Past historic records of the structure or similar structures may be used in the evaluation, including the effects of subsequent alterations. The capability of the structure to carry vertical and horizontal loads shall be evaluated. A complete, continuous and adequate stress path, including connections, from every part or portion of the structure to the ground shall be provided for the required vertical and horizontal forces.

Parapets and exterior decoration shall be investigated for conformance with the Building Code or evaluation methodologies and anchorage with the ability to resist seismic forces shall be required, except in the case where those parapets or decoration are judged to present no hazard to life safety.

A report shall be made of the findings of the survey and evaluation noting all deterioration of the existing structure and making recommendations for the repair of deterioration and for any reconstruction or strengthening which should be undertaken. Plans and specifications for the work done pursuant to the survey and evaluation prepared under this section shall be prepared under the responsible charge of an architect or structural engineer.

[Statutory Authority: RCW 19.27.120 and 19.27.074. 91-01-103, § 51-19-500, filed 12/18/90, effective 7/1/91.]

(2003 Ed.)

WAC 51-19-510 Alternatives. Alternative materials and methods of construction may be substituted for those otherwise required by the HBC or by the recommendations of the earthquake survey and evaluation provided the alternative methods are necessary to preserve historic materials or features and that such alternative methods provide satisfactorily for the purposes intended, or are reasonably equivalent to the prescribed methods in quality, strength, effectiveness, fire resistance, durability, and safety.

The building official may request that sufficient evidence be submitted to substantiate any claims made regarding such alternative materials, evaluation methodologies, and alternative methods of construction.

[Statutory Authority: RCW 19.27.120 and 19.27.074. 91-01-103, § 51-19-510, filed 12/18/90, effective 7/1/91.]

PART VI CHANGE OF OCCUPANCY STANDARDS

WAC 51-19-600 General. The character of the occupancy of historic buildings and structures may be changed, provided the requirements of this chapter are met. Where no specific requirements are included herein, the building or structure shall comply with the Building Code.

Every change of occupancy to a classification in a different group or different division of the same group shall require a new certificate of occupancy regardless of whether any alterations are required by the HBC.

If the building or portion thereof does not conform to the requirements of the HBC for the proposed occupancy group or division, the building or portion thereof shall be made to conform to the Building Code except as specified in the HBC. The building official may issue a new certificate of occupancy stating that the building complies with the HBC.

The relative degree of hazard between different occupancy groups or between divisions of the same group shall be as set forth in the hazard category classifications, Tables Nos. VI-1 through VI-5. A historic building may have its occupancy changed to an occupancy within the same hazard group or to an occupancy in a lesser hazard group without complying with all of the provisions of this chapter. A historic building shall comply with the requirements of the Building Code, except as specified in this chapter, when a change in occupancy will place it in a higher hazard group or when the occupancy is changed to Group A, Division 1 or 2, Group E, H, or I.

[Statutory Authority: RCW 19.27.120 and 19.27.074. 91-01-103, § 51-19-600, filed 12/18/90, effective 7/1/91.]

WAC 51-19-610 Heights and area. Heights and areas of buildings and structures shall meet the requirements of the Building Code for the new occupancy.

Exception: Historic buildings exceeding the maximum allowable heights and areas permitted for new buildings may undergo a change of occupancy if the hazard level of the new occupancy is equal to or less than the existing hazard group as shown in Table No. VI-1.

[Statutory Authority: RCW 19.27.120 and 19.27.074. 91-01-103, § 51-19-610, filed 12/18/90, effective 7/1/91.]

(2003 Ed.)

WAC 51-19-620 Fire safety. (1) When a change of occupancy is made to a higher hazard group as shown in Table No. VI-1, all elements of the exit system shall comply with the requirements of the Building Code.

EXCEPTIONS: (a) Existing exit corridors and stairways meeting the requirements of Part IV of this chapter may be used.
(b) Exit system elements may meet alternative compliance requirements as approved by the building official.

(2) Existing exit systems complying with Part IV shall be accepted if the occupancy change is to an equal or lesser hazard group when evaluated in accordance with Table No. VI-2.

(3) When a change of occupancy is made to a higher hazard group as shown in Table No. VI-3, occupancy separations shall be provided as specified in the Building Code. When approved by the building official, existing wood lath and plaster in good condition or one-half inch gypsum wall board may be accepted where a one hour occupancy separation is required.

(4)(a) Vertical shafts may be designed to meet the requirements of atriums as required by the Building Code or the requirements of this chapter.

(b) Interior stairways shall be enclosed as required by the Building Code when a change of occupancy is made to a higher hazard group as shown in Table No. VI-4.

EXCEPTIONS: (i) In other than Group I Occupancies, an enclosure will not be required for openings serving only one adjacent floor and not connected with corridors or stairways serving other floors.
(ii) Existing stairways not enclosed need not be enclosed in a continuous vertical shaft if each story is separated from other stories by one hour fire resistive construction or approved wired glass set in steel frames and all exit corridors are sprinklered. The openings between the corridor and occupant space shall have at least one quick response sprinkler head above the openings on the tenant side, with a draft gasket assembly on sound, solid, self-closing doors. The sprinkler system may be supplied from the domestic water supply system, provided the system is of adequate pressure, capacity, and sizing for the combined domestic and sprinkler requirements.

(c) Interior shafts, including, but not limited to, elevator hoistways, service and utility shafts, shall be enclosed with a minimum of one-hour fire-resistive construction.

EXCEPTIONS: (i) Vertical openings, other than stairways, need not be enclosed if the entire building is provided with an approved automatic sprinkler system. The sprinkler system may be supplied from the domestic water supply system, provided the system is of adequate pressure, capacity, and sizing for the combined domestic and sprinkler requirements.
(ii) Where one-hour fire-resistive floor construction is required, vertical shafts need not be enclosed when such shafts are blocked at every floor level by the installation of not less than two full inches of solid wood or equivalent construction.

(d) All openings into such shafts shall be protected by fire assemblies having a fire protection rating of not less than one hour and shall be maintained self-closing or shall be automatic closing by actuation of a smoke detector. All other openings shall be fire protected in an approved manner. Existing fusible link-type automatic door-closing devices may be permitted if the fusible link rating does not exceed one hundred thirty-five degrees.

[Statutory Authority: RCW 19.27.120 and 19.27.074. 91-01-103, § 51-19-620, filed 12/18/90, effective 7/1/91.]

[Title 51 WAC—p. 131]

WAC 51-19-630 Property protection. (1) Exterior walls shall have fire resistance and opening protection as set forth in the Building Code. This provision shall not apply to walls at right angles to the property line.

EXCEPTIONS: (a) Where a fire-resistive rating greater than two hours is required for a building of any type of construction, existing noncombustible exterior walls having a fire resistive rating equivalent to two hours as determined by the building official may be accepted, provided:
 (i) The building is classified as a Group A, Division 3; Group B, Division 1 or Group B, Division 2 Occupancy; and
 (ii) The building does not exceed three stories in height; or
 (iii) The building shall be of heavy timber construction, and does not exceed five stories in height. (The state Building Code council recommends the use of Guideline 2 of the Uniform Code for Building Conservation as reference in determining fire resistive rating equivalency.)
 (b) Existing exterior walls shall be accepted if the occupancy is changed to a hazard group which is equal to or less than the existing occupancy as defined in Table No. VI-4.

(2) New openings in exterior walls shall be protected as required by the Building Code. Existing, nonconforming openings shall be protected by fire assembly having a minimum three-fourth hour fire protection rating, and where operable be self-closing. When openings in the exterior walls are required to be protected due to distance from the property line, the sum of the area of such openings shall not exceed fifty percent of the total wall area in each story.

EXCEPTIONS: (a) Protected openings shall not be required for Group R, Division 1 Occupancies which do not exceed three stories in height and which are located not less than three feet from the property line.
 (b) Where opening protection is required, an automatic fire extinguishing system throughout may be substituted for opening protection.
 (c) Opening protection may be omitted when the change of occupancy is to an equal or lower hazard classification in accordance with Table No. VI-2.
 (d) The building shall be of heavy timber construction, and does not exceed five stories in height.

[Statutory Authority: RCW 19.27.120 and 19.27.074. 91-01-103, § 51-19-630, filed 12/18/90, effective 7/1/91.]

WAC 51-19-640 Structural safety. Buildings and structures shall meet the minimum level of performance for structural safety as specified in Parts IV and V of this chapter.

Historic buildings may undergo a change of occupancy if the hazard group is equal to or less than the existing occupancy as shown in Table No. VI-5. Buildings undergoing a change of occupancy to a more hazardous group shall meet the earthquake hazard reduction requirements of Part V of this chapter for the new occupancy.

[Statutory Authority: RCW 19.27.120 and 19.27.074. 91-01-103, § 51-19-640, filed 12/18/90, effective 7/1/91.]

WAC 51-19-650 Light and ventilation. When deemed necessary by the building official, light and ventilation shall comply with the requirements of the Building Code.

[Statutory Authority: RCW 19.27.120 and 19.27.074. 91-01-103, § 51-19-650, filed 12/18/90, effective 7/1/91.]

WAC 51-19-660 Flame spread reduction. Where finish materials are required to have a flame-spread classification of Class III or better, existing nonconforming materials

shall be surfaced with an approved fire retardant paint or finish.

[Statutory Authority: RCW 19.27.120 and 19.27.074. 91-01-103, § 51-19-660, filed 12/18/90, effective 7/1/91.]

WAC 51-19-670 Roof coverings. Regardless of occupancy group, roof covering materials not less than Class C shall be permitted where a fire retardant roof covering is required. Nonrated materials may be acceptable only where approved by the building official.

TABLE NO. VI-1

HEIGHTS AND AREAS
HAZARD CATEGORIES AND CLASSIFICATIONS

Relative Hazard	Occupancy Classification*
1	A-1, H, I-3 (highest hazard group)
2	A-2, A-2.1, I-1, I-2
3	A-3, A-4, B, E, R-1
4	R-3, M (lowest hazard group)

*See Table 5-A of the Building Code.

TABLE NO. VI-2

LIFE SAFETY AND EXITS
HAZARD CATEGORIES AND CLASSIFICATIONS

Relative Hazard	Occupancy Classification*
1	A-1, A-2, A-2.1, E, I, H-1, H-2, H-3 and H-7 (highest hazard group)
2	A-3
3	R-1, R-3, B-2 dining and drinking establishments
4	B-2 all others, B-4, H other than H-1, H-2, H-3 and H-7
5	B-1, B-3
6	M (lowest hazard group)

*See Table 5-A of the Building Code.

TABLE NO. VI-3

OCCUPANCY SEPARATIONS
HAZARD CATEGORIES AND CLASSIFICATIONS

Relative Hazard	Occupancy Classification*
1	B-1, H, I (highest hazard group)
2	A, B-2, B-3, B-4
3	E
4	R-1, M
5	R-3 (lowest hazard group)

*See Table 5-A of the Building Code.

TABLE NO. VI-4

EXPOSURE OF EXTERIOR WALLS AND STAIRWAY ENCLOSURES
HAZARD CATEGORIES AND CLASSIFICATIONS

Relative Hazard	Occupancy Classification*
1	H (highest hazard group)
2	B-2 mercantile and warehouses

TABLE NO. VI-4

EXPOSURE OF EXTERIOR WALLS
AND STAIRWAY ENCLOSURES

HAZARD CATEGORIES AND CLASSIFICATIONS

3	A, E, I
4	B-1, B-2 all others, R
5	B-4, M (lowest hazard group)

*See Table 5-A of the Building Code.

TABLE NO. VI-5

EARTHQUAKE SAFETY
HAZARD CATEGORIES AND CLASSIFICATIONS

Relative Hazard	Occupancy Classification*
1	A, E, I (highest hazard group)
2	R-1
3	B-3, B-4, H
4	B-1, B-2
5	R-3, M (lowest hazard group)

*See Table 5-A of the Building Code.

[Statutory Authority: RCW 19.27.120 and 19.27.074. 91-01-103, § 51-19-670, filed 12/18/90, effective 7/1/91.]

PART VII

ACCESSIBILITY TO PERSONS WITH DISABILITIES

WAC 51-19-700 General. The HBC shall provide the standards for accessibility of historic buildings to persons with disabilities. The value of access to buildings, structures, and sites of historic and cultural significance can be best obtained by providing the greatest degree of access while preserving the historic or architectural features of a building. Where accessibility is required by chapter 51-10 WAC, such standards shall be incorporated as practical.

Code users may consult the appendix bibliography concerning accessibility designs in historic buildings. Appendix Table A- 901 is also provided to assist in application of the code.

Where additions are undertaken they shall incorporate useful accessible design features.

[Statutory Authority: RCW 19.27.120 and 19.27.074. 91-01-103, § 51-19-700, filed 12/18/90, effective 7/1/91.]

WAC 51-19-710 Building access and use. (1) Entry. At least one primary entrance to a historic building shall be usable by persons with disabilities. When the building official, building designer, and local or state preservation officer concur that adaptation of a primary entrance will have a detrimental impact on the aesthetic or historic context of the entrance, then the building official may accept a reasonable alternate public entrance. When access is provided by other than a primary entrance, the entrance access shall be clearly indicated by directional signs. Accessible parking shall be located so as to provide the closest practical distance to the accessible entrance.

(2) Ramps.

(a) General. The building official shall accept alternate ramp designs which comply with the HBC when it is deter-

(2003 Ed.)

mined that installation of a ramp having a slope which complies with chapter 51-10 WAC cannot be achieved.

(b) Slope. The slope of the ramp shall be not steeper than one vertical to nine horizontal for a horizontal length not to exceed twelve feet. Ramps which have a horizontal length which does not exceed two feet may have a slope not to exceed one vertical to six horizontal. Adequate warnings shall be posted indicating steepness where slopes exceed the requirements provided in the regulations for barrier-free facilities.

(3) Doors. Existing doorways which provide a net clear opening of not less than twenty-nine and one-half inches shall be deemed to meet the access requirements of this chapter.

(4) Changes in elevation. Changes in elevation of portions of buildings on accessible routes of travel shall be accessible by ramps or lifts consistent with the intent of the HBC.

(5) Toilet rooms. Where toilet facilities are provided, at least one such facility designed for use by persons with disabilities, shall be provided for each sex, or a separate facility usable by either sex located along an accessible route of travel. Alternate provisions providing substantially equivalent facilities shall comply with this code.

[Statutory Authority: RCW 19.27.120 and 19.27.074. 91-01-103, § 51-19-710, filed 12/18/90, effective 7/1/91.]

PART VIII

ENERGY CONSERVATION

WAC 51-19-800 General. Historic buildings shall comply with the energy conservation and ventilation and indoor air quality requirements of the Washington State Energy Code chapter 51-11 WAC and the Washington State Ventilation and Indoor Air Quality Code chapter 51-13 WAC. The building official may modify the specific requirements of the Energy Code for Historic Buildings and require in lieu thereof alternate requirements which will result in a reasonable degree of energy efficiency.

EXCEPTIONS: The historic elements of the following buildings and structures are exempt from the State Energy Code:
-Totally preserved buildings used as historical exhibits.
-Seasonal use buildings.

[Statutory Authority: RCW 19.27.120 and 19.27.074. 91-01-103, § 51-19-800, filed 12/18/90, effective 7/1/91.]

WAC 51-19-810 Alternative energy conservation provisions. (1) General. The alternative energy conservation requirements as specified in this part may be applied to a historic building if approved by the building official. The building official may approve other alternatives designed to improve energy efficiency without loss of the historic fabric of the building.

(2) Building envelope requirements. Historic buildings shall meet the minimum thermal performance values specified in the energy code, or the alternative measures specified in this subsection.

(a) Attics. Where accessible, insulation shall be installed in the attic to the requirements of the Energy Code, or lesser levels to maintain adequate ventilation, to reduce condensa-

tion problems or to provide safety clearances around electrical wiring or utility systems.

Additional insulation with an integral vapor barrier shall not be installed on top of existing insulation. A vapor barrier shall not be installed between layers of insulation.

(b) Exterior walls. Accessible wall cavities where finishes are being disturbed by alteration or renovation work shall be insulated to the extent practical. If accessible, a vapor retarder shall be installed on the winter warm side of the insulation (facing the conditioned space). An approved vapor retarding paint or clear finish is an acceptable vapor retarder. Permeable materials on the exterior side of the cavity (or unheated side) or an air space or means of venting framing cavities to the exterior are required if insulation is added to the cavities in wood frame construction.

(c) Doors. Doors which are not of the original material or which are not replicas designed to be compatible with the historic aspects of the structure shall conform to the requirements of the Energy Code.

(d) Floors over crawl spaces. If accessible, adequately ventilated, and with ground clearance in conformance with Building Code requirements, insulation with an R-value of eleven or greater shall be installed in floors of unheated crawl spaces.

(e) Moisture control in crawl spaces. Minimum foundation ventilation shall be provided in unheated crawl spaces. The net-free area of ventilation shall be at least 1/300th of the floor area. The vents shall be distributed around the perimeter of the foundation as equally as practical to provide adequate cross-ventilation. If accessible, a black polyethylene vapor barrier shall be applied to cover the exposed earth as prescribed in the Building Code.

(f) Air leakage. Windows and doors.

(i) All exterior windows and doors shall be gasketed or weatherstripped.

(ii) If the existing windows and doors are replaced with factory manufactured windows, the windows shall be double glazed units or shall be equipped with interior or exterior storm windows.

(iii) Single glazed windows which are part of the historic features of the building may be retained, repaired, or restored with or without the addition of storm windows.

(g) Chimney flues. Chimney flues which are no longer in use shall be closed off and sealed against air leakage.

(h) Exterior openings. The following openings in the exterior building envelope shall be caulked, gasketed, or otherwise sealed:

- (i) Exterior joints around window and door frames;
- (ii) Penetrations of utility services through walls, floors, and roofs.

(iii) Any other penetrations as required by the building official.

(i) Insulation materials. New insulation materials shall conform to the applicable provisions of the building, mechanical, plumbing, and energy codes for fire-resistance, flame-spread, smoke-density ratings and Building Code provisions for roof and exposed deck ceiling insulation.

(3) Building mechanical systems. Existing heating, ventilation, and cooling systems which are part of the significant historic features of the building or structure, and which in the opinion of the building official do not constitute a safety hazard, may remain in use, be repaired or be replaced in kind. Replacement, alteration, or addition of other heating, ventilation, and cooling equipment shall comply with the provisions of the energy, ventilation and indoor air quality, mechanical, and plumbing codes.

(4) Water heating. Replacement or addition of water heating equipment shall comply with the provisions of the Energy Code.

(5) Lighting. Existing lighting may be retained, repaired, and replaced in kind or with replica fixtures. Areas of buildings or structures in which lighting is being replaced shall conform to the requirements of the Energy Code where practical. Appropriate clearances of insulation material from sources of heat; i.e., light fixtures, shall be as required by the Building Code requirements.

[Statutory Authority: RCW 19.27.120 and 19.27.074. 91-01-103, § 51-19-810, filed 12/18/90, effective 7/1/91.]

**PART IX
APPENDICES**

WAC 51-19-900 Appendix A.

Table A - 901

	BUILDING FEATURES			
	ENTRY	DOORS	TOILET ROOMS	FLOORS & LEVELS
	Prevailing Codes:	Prevailing Codes:	Prevailing Codes:	Prevailing Codes:
Instructions:				
1. Determine Building Category; i.e., I.I.D. under Building Type and Historical Aspects.	Primary public entrance with access to elevators available	-31 1/2" clear openings -5' level perpendicular to closed door -18" clear at strike side	5'-0" x 4'-8" stall clear Length 32" min. clear entry in front of compartment Door 32" clear Turn 60" diameter circle Lavy. 29" clear under for newly designed space. See WAC 51-10 Sec. 511.1.	-Access to all floors, except in offices, retail shops -Floor on given story level or ramped.
2. Go to box in category under Building Features.				
3. Numbers in box refer to the Alternatives List.				

BUILDING FEATURES

Category (Building Type and Historical Aspects)	ENTRY ENTRY See Alternatives List	DOORS DOORS See Alternatives List	TOILET ROOMS TOILET ROOMS See Alternatives List	FLOORS & LEVELS FLOORS & LEVELS See Alternatives List
I. Publicly owned or leased building providing governmental services to general public; i.e., City Hall, Courthouse, etc., adaptive use, restoration, or reconstruction.				
A. Exterior (shell) historical all or part, Interior nonhistorical.	2, 4	1, Exterior only None interior	None	N.A.
B. Interior historical - all or part, Exterior nonhistorical.		1,2 Interior only None exterior	1, 2	1, 2
C. All historical major change in use, change in occupancy.	2, 4	1, Exterior 1, 2 Interior only	1, 2	1, 2
D. All historical - minor change in use to equal or less intensive occupancy. Limited services.	2, 4	1, Exterior 1,2, Interior only	1, 2	1, 2
II. Privately owned buildings offering services to consumers; i.e., taverns, restaurants, general shops, etc., or buildings owned by government and leased or consigned to private operator.				
A. Adaptive use restoration, reconstruction, Interior nonhistoric, Exterior historical (all or part).	1, 2, 3, 4	1, Exterior, and 1 Interior.	None	N.A.
B. Interior historical - (all or part), Exterior		None exterior,	1, 2, 3	N.A.
C. All historical - major change in use, change in occupancy, or mixed occupancy. Minor change of use to equal or less intensive occupancy.	1, 2, 3, 4	1, 2, 3	1, 2, 3	1, 2, 3
D. Reconstruction, or restoration. No change in use except to museum. (Minor mixed occupancy with administration space would be allowed.)	1, 2, 3, 4	1, 2, 3	1, 2, 3	1, 2, 3
E. Museum quality restoration and/or reconstruction including museum use. (Minor mixed occupancy compatible with that use would be allowed.) Also includes renovation of historical building or site.	1, 2, 3, 4	1, 2, 3	1, 2, 3	1, 2, 3
III. Privately or publicly owned buildings used as museums or as site for display of the building itself; i.e., museum, schoolhouse, garden centers, galleries, etc.				
A. Reconstruction, or restoration. No change in use except to museum. (Minor mixed occupancy such as administrative would be allowed).	1, 2, 3, 4	1, 2, 3	1, 2, 3	1, 2, 3
B. Museum quality restoration and/or reconstruction museum use (Minor mixed occupancy compatible with that would be allowed). Also includes renovation of historical building or site.	1, 2, 3, 4	1, 2, 3	1, 2, 3	1, 2, 3
IV. Privately owned buildings not open to general public but employing 3 or more persons; i.e., business offices.				
A. Adaptive use - Interior nonhistorical, Exterior historical (all or part).	1, 2, 3, 4	1, 2, 3, Exterior, None interior	1, 2	1, 2, 3, Exterior Access, None interior access
B. Adaptive use - Interior historical, Exterior nonhistorical.	1, 2, 3, 4	None exterior, 1, 2, 3, interior	1, 2	None exterior access, 1, 2, 3, interior access
C. All historical - major change in use, change in occupancy or mixed occupancy. Minor change of use to equal or less intensive occupancy.	1, 2, 3, 4	1 through 3	1, 2	1, 2, 3
D. Reconstruction, or restoration. No change in use - except to museum. (Minor mixed occupancy such as administrative would be allowed.)	1, 2, 3, 4	1 through 3	1, 2	1, 2, 3
V. Buildings employing less than 3 people.	All alternatives 1, 2, 3, 4	All alternatives 1 - 3	All alternatives 1 - 3	All alternatives 1 - 3

ALTERNATIVES LIST

These alternatives are listed in order of priority and are to be used with Table A-901.

ENTRY:

1. Ramp at greater than standard slope, but no greater than 1:9 for a horizontal distance not to exceed 12 feet at main, side, or rear entrance.
2. Access, listed in the order of priority, at grade or by ramp or lift to any entrance used by general public.
3. Ramp no greater than 1:6 slope for a distance not to exceed a horizontal distance of 2 feet at main, side, or rear entrance.
4. Access, listed in the order of priority, at grade, or by ramp, or lift at any entrance not used by general public but open (unlocked), with directional signs.

DOORS: (One means of entry into spaces requiring access)

1. 30-inch width of clear opening operable by single motion.
2. Usable 29 1/2 inches 66-175 clear opening with door(s) operable by single motion.
3. Single or double door to provide a usable 29 1/2 inches clear opening.

TOILET ROOMS:

1. Toilet facility of dimensions no less than those provided in the prevailing provisions in chapter 51-10 WAC designated as a unisex toilet for disabled persons.
2. Provide unisex toilet for disabled persons and general public.
3. No toilet for anyone.

FLOORS AND LEVELS:

1. Access to experiences, services, functions and materials and resources; i.e., maps, plans, courtroom, council chambers, etc., at accessible levels.
2. Access provided to levels and floors by ramps of greater than standard slope and no greater than 1:9 for horizontal distances not to exceed 12 feet. Lifts may be provided.
3. Access provided to levels and floors by ramps of 1:6 slope for horizontal distance not to exceed 2 feet. Adequate warnings shall be provided to indicate steepness of the slope.

USE NOTES:

1. Listed alternatives only apply to building requiring construction permits.
2. These alternatives should be used only where it is not possible to meet prevailing code.
3. Alternatives should be used only in those portions of the building that are historical.
4. Alternatives apply to access for physically disabled persons.
5. Alternatives apply to historic buildings only.
6. For other accessibility standards, see chapter 51-10 WAC.
7. Alternatives are listed in priority order.
8. No alternatives are allowed for simulations.

[Statutory Authority: RCW 19.27.120 and 19.27.074. 91-01-103, § 51-19-900, filed 12/18/90, effective 7/1/91.]

[Title 51 WAC—p. 136]

WAC 51-19-901 Appendix B—Bibliography.

Mace, Ronald I., **Accessibility Modifications**, North Carolina Department of Insurance, 1976, 67 pages, illustrated.

The Association for Preservation Technology, **Regulating Existing Buildings**, "The Accessible Path in Historic Properties."

Theodore Prudon and Stephen Dalton, Vol. XIII, No. 2, 1981.

Parrott, Charles A., **Access to Historic Buildings for the Disabled**, Washington, D.C.: Heritage Conservation and Recreation Service, 1980.

"Designing barrier-free toilet rooms within old and new buildings" **Architectural Record**, V. 166, October 1979, p. 57-59, diagrams.

Kenney, A.P., "Open Door for the Handicapped" **Historic Preservation**, v. 30, July 1978, P.2,3+, illustrations.

Ballantyne, Duncan S., **Accommodation of disabled visitors at historic sites in the National Park System**, Washington, U.S. National Park Service, 1983.

Cotler, Stephen Richard, **Modifying the existing campus building for accessibility; construction guidelines and specifications**, Washington, Association of Physical Plant Administrators of Universities and Colleges, 1981.

Kenney, Alice P., **Access to the Past: Museum Programs and Handicapped Visitors. A guide to Section 504 - making existing programs and facilities accessible to disabled patrons**. Nashville, Tennessee, American Association for State and Local History, 1988.

Milner, Margaret, **Adapting Historic Campus Structures for Accessibility**. Washington, Association of Physical Plant Administrators of Universities and Colleges; National Center for a Barrier-Free Environment, 1980.

U.S. Library of Congress. National Library Service for the Blind and Physically Handicapped. **Planning barrier-free libraries; a guide for renovation and construction of libraries serving blind and physically handicapped readers**. Washington, 1981.

[Statutory Authority: RCW 19.27.120 and 19.27.074. 91-01-103, § 51-19-901, filed 12/18/90, effective 7/1/91.]

Chapter 51-40 WAC

STATE BUILDING CODE ADOPTION AND AMENDMENT OF THE 1997 EDITION OF THE UNIFORM BUILDING CODE

WAC

51-40-001	Authority.
51-40-002	Purpose.
51-40-003	Uniform Building Code.
51-40-004	Conflicts with Washington State Ventilation and Indoor Air Quality Code.
51-40-005	Uniform Building Code requirements for barrier-free accessibility.
51-40-007	Exceptions.
51-40-008	Implementation.
51-40-009	Recyclable materials and solid waste storage.

(2003 Ed.)

51-40-0200	Chapter 2—Definitions and abbreviations.
51-40-0302	Section 302—Mixed use or occupancy.
51-40-0303	Section 303—Requirements for Group A Occupancies.
51-40-0304	Section 304—Requirements for Group B Occupancies.
51-40-0305	Section 305—Requirements for Group E Occupancies.
51-40-0307	Section 307—Requirements for Group H Occupancies.
51-40-0308	Section 308—Requirements for Group I Occupancies.
51-40-0310	Section 310—Requirements for Group R Occupancies.
51-40-0311	Section 311—Requirements for Group S Occupancies.
51-40-0313	Section 313—Requirements for Group LC Occupancies.
51-40-0403	Section 403—Special provisions for Group B office buildings and Group R, Division I Occupancies.
51-40-0405	Section 405—Stages and platforms.
51-40-0510	Section 510—Heating.
51-40-0804	Section 804—Maximum allowable flame spread.
51-40-0902	Section 902—Standards of quality.
51-40-0904	Section 904—Fire-extinguishing systems.
51-40-0905	Section 905—Smoke control.
51-40-1000	Chapter 10—Means of egress.
51-40-1002	Definitions.
51-40-1003	General egress requirements.
51-40-1004	The exit access.
51-40-1007	Means of egress requirements based on occupancy.
51-40-1091	Table 10-A.
51-40-1100	Chapter 11—Accessibility.

PART I - GENERAL

51-40-1101	Section 1101—Scope.
51-40-1102	Section 1102—Definitions.

PART II - NEW CONSTRUCTION

51-40-1103	Section 1103—Building accessibility.
51-40-1104	Section 1104—Egress and areas of evacuation assistance.
51-40-1105	Section 1105—Facility accessibility.
51-40-1106	Section 1106—Accessible design and standards.
51-40-1107	Section 1107—Parking facilities.
51-40-1108	Section 1108—Passenger loading zones.

PART III - ACCESSIBILITY FOR EXISTING BUILDINGS

51-40-1109	Section 1109—Scope.
51-40-1110	Section 1110—Definitions.
51-40-1111	Section 1111—Additions.
51-40-1112	Section 1112—Alterations.
51-40-1113	Section 1113—Historic preservation.
51-40-1114	Section 1114—Appeal.
51-40-1191	Table No. 11-A.
51-40-1192	Table No. 11-B.
51-40-1193	Table No. 11-C.
51-40-1194	Table No. 11-D.
51-40-1195	Table No. 11-E.
51-40-1196	Table No. 11-F.
51-40-1202	Section 1202—Light and ventilation in Groups A, B, E, F, H, I, M and S Occupancies.
51-40-1203	Section 1203—Light and ventilation in Group R Occupancies.
51-40-1616	Section 1616—Definitions.
51-40-1702	Section 1702—Structural observation.
51-40-1909	Section 1909—Strength and serviceability requirements.
51-40-2406	Section 2406—Safety glazing.
51-40-2900	Chapter 29—Plumbing systems.
51-40-2929	Table 29-A—Minimum plumbing fixtures.
51-40-3004	Hoistway venting.
51-40-3102	Section 3102—Chimneys, fireplaces and barbecues.
51-40-31200	Section 31-2—Standard test method for particulate emissions from fireplaces.
51-40-3404	Section 3404—Moved buildings.
51-40-93115	Section 93115.
51-40-93116	Section 93116.
51-40-93117	Section 93117.
51-40-93118	Section 93118.
51-40-93119	Section 93119.
51-40-93120	Section 93120.

DISPOSITION OF SECTIONS FORMERLY CODIFIED IN THIS CHAPTER

51-40-23110	Wood structural panel and particleboard shear walls tables. [Statutory Authority: RCW 19.27.031 and 19.27.074. 98-02-054, § 51-40-23110, filed 1/6/98, effective 7/1/98.] Repealed by 98-24-076, filed 12/1/98,
-------------	---

effective 7/1/99. Statutory Authority: RCW 19.27.074, 19.27.031 and 19.27.074 (1)(a).

WAC 51-40-001 Authority. These rules are adopted under the authority of chapter 19.27 RCW.

[Statutory Authority: RCW 19.27.031 and 19.27.074. 98-02-054, § 51-40-001, filed 1/6/98, effective 7/1/98.]

WAC 51-40-002 Purpose. The purpose of these rules is to implement the provisions of chapter 19.27 RCW, which provides that the State Building Code council shall maintain the State Building Code in a status which is consistent with the purpose as set forth in RCW 19.27.020. In maintaining the codes the council shall regularly review updated versions of the codes adopted under the act, and other pertinent information, and shall amend the codes as deemed appropriate by the council.

[Statutory Authority: RCW 19.27.031 and 19.27.074. 98-02-054, § 51-40-002, filed 1/6/98, effective 7/1/98.]

WAC 51-40-003 Uniform Building Code. The 1997 edition of the Uniform Building Code as published by the International Conference of Building Officials and available from the International Conference of Building Officials, 5360 Workman Mill Road, Whittier, California 90601 is hereby adopted by reference with the following additions, deletions, and exceptions.

[Statutory Authority: RCW 19.27.031 and 19.27.074. 98-02-054, § 51-40-003, filed 1/6/98, effective 7/1/98.]

WAC 51-40-004 Conflicts with Washington State Ventilation and Indoor Air Quality Code. In the case of conflict between the ventilation requirements of Chapter 12 of this code and the ventilation requirements of chapter 51-13 WAC, the Washington State Ventilation and Indoor Air Quality Code, the provisions of the Ventilation and Indoor Air Quality Code shall govern.

[Statutory Authority: RCW 19.27.031 and 19.27.074. 98-02-054, § 51-40-004, filed 1/6/98, effective 7/1/98.]

WAC 51-40-005 Uniform Building Code requirements for barrier-free accessibility. Chapter 11 and other Uniform Building Code requirements for barrier-free access are adopted pursuant to chapters 70.92 and 19.27 RCW.

Pursuant to RCW 19.27.040, Chapter 11 and requirements affecting barrier-free access in Sections 1003.3.1.1, 1003.3.1.2, 1003.3.1.5, 1003.3.1.6, 1003.3.3.3, 1003.3.3.5, 1003.3.3.6, 1003.3.3.13, 1003.3.4.4, 1003.3.4.5, shall not be amended by local governments.

[Statutory Authority: RCW 19.27.031 and 19.27.074. 98-02-054, § 51-40-005, filed 1/6/98, effective 7/1/98.]

WAC 51-40-007 Exceptions. The exceptions and amendments to the Uniform Building Code contained in the provisions of chapter 19.27 RCW shall apply in case of conflict with any of the provisions of these rules.

Table 10-D, Section 1607.6 and Section 3003 (with the exception of 3003.3 Standby Power and 3003.5 Stretcher Requirements) of the 1997 Uniform Building Code are not adopted.

The provisions of this code do not apply to temporary growing structures used solely for the commercial production of horticultural plants including ornamental plants, flowers, vegetables, and fruits. "Temporary growing structure" means a structure that has the sides and roof covered with polyethylene, polyvinyl, or similar flexible synthetic material and is used to provide plants with either frost protection or increased heat retention. A temporary growing structure is not considered a building for purposes of this code.

The provisions of this code do not apply to the construction, alteration, or repair of temporary worker housing except as provided by rule adopted under chapter 70.114A RCW or chapter 37, Laws of 1998 (SB 6168). "Temporary worker housing" means a place, area, or piece of land where sleeping places or housing sites are provided by an employer for his or her employees or by another person, including a temporary worker housing operator, who is providing such accommodations for employees, for temporary, seasonal occupancy, and includes "labor camps" under RCW 70.54.110.

[Statutory Authority: RCW 19.27.031 and 19.27.074. 98-24-078, § 51-40-007, filed 12/1/98, effective 7/1/99; 98-02-054, § 51-40-007, filed 1/6/98, effective 7/1/98.]

WAC 51-40-008 Implementation. The Uniform Building Code adopted under chapter 51-40 WAC shall become effective in all counties and cities of this state on July 1, 1998.

[Statutory Authority: RCW 19.27.031 and 19.27.074. 98-02-054, § 51-40-008, filed 1/6/98, effective 7/1/98.]

WAC 51-40-009 Recyclable materials and solid waste storage. For the purposes of this section, the following definition shall apply:

RECYCLED MATERIALS means those solid wastes that are separated for recycling or reuse, such as papers, metals and glass.

All local jurisdictions shall require that space be provided for the storage of recycled materials and solid waste for all new buildings.

EXCEPTION: Group R, Division 3 and Group U Occupancies.

The storage area shall be designed to meet the needs of the occupancy, efficiency of pickup, and shall be available to occupants and haulers.

[Statutory Authority: RCW 19.27.031 and 19.27.074. 98-02-054, § 51-40-009, filed 1/6/98, effective 7/1/98.]

WAC 51-40-0200 Chapter 2—Definitions and abbreviations.

SECTION 202 - A.

ADULT FAMILY HOME means a family abode in which a person or persons provide personal care, special care, room and board to more than one but not more than six adults who are not related by blood or marriage to the person or persons providing the services.

[Title 51 WAC—p. 138]

SECTION 204 - C.

CHILD DAY CARE, shall, for the purposes of these regulations, mean the care of children during any period of a 24 hour day.

CHILD DAY CARE HOME, FAMILY is a child day care facility, licensed by the state, located in the family abode of the person or persons under whose direct care and supervision the child is placed, for the care of twelve or fewer children, including children who reside at the home.

SECTION 207 - F.

FAMILY ABODE means a single dwelling unit and accessory buildings occupied for living purposes by a family which provides permanent provisions for living, sleeping, eating, cooking, and sanitation.

FLOOR AREA is the area included within the surrounding exterior walls of a building or portion thereof, exclusive of vent shafts, courts, and gridirons. The floor area of a building, or portion thereof, not provided with surrounding exterior wall shall be the usable area under the horizontal projection of the roof or floor above.

SECTION 217 - P.

PORTABLE SCHOOL CLASSROOM is a structure, transportable in one or more sections, which requires a chassis to be transported, and is designed to be used as an educational space with or without a permanent foundation. The structure shall be trailerable and capable of being demounted and relocated to other locations as needs arise.

SECTION 220 - S.

STRUCTURAL OBSERVATION means the visual observation of the structural system, for general conformance to the approved plans and specifications. Structural observation does not include or waive the responsibility for the inspections required by Sections 108 and 1701 or other sections of the code.

SURGICAL AREA is the preoperating, operating, recovery and similar rooms within an outpatient health-care center where the patients are incapable of unassisted self-preservation.

[Statutory Authority: RCW 19.27.031, 19.27.074. 01-02-095, § 51-40-0200, filed 1/3/01, effective 7/1/01; 98-02-054, § 51-40-0200, filed 1/6/98, effective 7/1/98.]

WAC 51-40-0302 Section 302—Mixed use or occupancy.

302.1 General. When a building is used for more than one occupancy purpose, each part of the building comprising a distinct "occupancy," as described in Section 301 shall be separated from any other occupancy as specified in Section 302.4.

EXCEPTIONS:

1. When an approved spray booth constructed in accordance with the Fire Code is installed, such booth need not be separated from Group B, F, H, M or S Occupancies.
2. The following occupancies need not be separated from the uses to which they are accessory:

2.1 Assembly rooms having a floor area of not over 750 square feet (69 m²).

2.2 Administrative and clerical offices and similar rooms which do not exceed 25 percent of the floor area of the major use when not related to Group H, Division 2 and Group H, Division 3 Occupancies.

2.3 Gift shops, administrative offices and similar rooms in Group R, Division 1 Occupancies not exceeding 10 percent of the floor area of the major use.

2.4 The kitchen serving the dining area of which it is a part.

2.5 Customer waiting rooms not exceeding 450 square feet (41.8 m²) when not related to Group H Occupancies and when such waiting rooms have an exit directly to the exterior.

2.6 Offices, mercantile, food preparation establishments for off-site consumption, personal care salons or similar uses in Group R dwelling units which are conducted primarily by the occupants of a dwelling unit, which are secondary to the use of the unit for dwelling purposes, and which do not exceed 500 square feet (46.4 m²).

3. An occupancy separation need not be provided between a Group R, Division 3 Occupancy and a carport having no enclosed uses above, provided the carport is entirely open on two or more sides.

4. A Group S, Division 3 Occupancy used exclusively for the parking or storage of private or pleasure-type motor vehicles need not be separated from a Group S, Division 4 Occupancy open parking garage as defined in Section 311.1.

When a building houses more than one occupancy, each portion of the building shall conform to the requirements for the occupancy housed therein.

An occupancy shall not be located above the story or height set forth in Table 5-B, except as provided in Section 506. When a mixed occupancy building contains a Group H, Division 6 Occupancy the portion containing the Group H, Division 6 Occupancy shall not exceed three stories or 55 feet (16 764 mm) in height.

[Statutory Authority: RCW 19.27.031 and 19.27.074. 98-02-054, § 51-40-0302, filed 1/6/98, effective 7/1/98.]

WAC 51-40-0303 Section 303—Requirements for Group A Occupancies.

303.5 Light, Ventilation and Sanitation. In Group A Occupancies, light, ventilation and sanitation shall be as specified in Chapters 12 and 29.

[Statutory Authority: RCW 19.27.031 and 19.27.074. 98-02-054, § 51-40-0303, filed 1/6/98, effective 7/1/98.]

WAC 51-40-0304 Section 304—Requirements for Group B Occupancies.

304.2.2.1 Laboratories and vocational shops. Laboratories or groups of laboratories under the same management and vocational shops in buildings used for educational purposes, and similar areas containing hazardous materials, shall be separated from each other and other portions of the building by not less than a one-hour fire-resistive occupancy separation. Laboratories or groups of laboratories may include accessory support areas such as offices. When the quantities of hazardous materials in such uses do not exceed those listed in Table 3-D or 3-E, the requirements of Sections 307.5 and 307.8 shall apply. When the quantities of hazardous materials in such uses exceed those allowed by Table 3-D or 3-E, the

(2003 Ed.)

use shall be classified as the appropriate Group H Occupancy.

Laboratories having an occupant load of 10 or more shall have at least two exits or exit-access doors from the room and all portions of the room shall be within 75 feet (22 860 mm) of an exit or exit-access door.

304.5 Light, Ventilation and Sanitation. In Group B Occupancies, light, ventilation and sanitation shall be as specified in Chapters 12 and 29.

304.5.1 is not adopted.

304.5.2 is not adopted.

[Statutory Authority: RCW 19.27.031 and 19.27.074. 98-02-054, § 51-40-0304, filed 1/6/98, effective 7/1/98.]

WAC 51-40-0305 Section 305—Requirements for Group E Occupancies.

305.1 Group E Occupancies Defined. Group E Occupancies shall be:

Division 1. Any building used for educational purposes through the 12th grade by 50 or more persons for more than 12 hours per week or four hours in any one day.

Division 2. Any building used for educational purposes through the 12th grade by less than 50 persons for more than 12 hours per week or four hours in any one day.

Division 3. Any building or portion thereof used for day care purposes for more than six persons.

EXCEPTION: Family child day care homes shall be considered Group R, Division 3 Occupancies.

For occupancy separations, see Table 3-B.

305.2.3 Special provisions. Rooms in Division 1 and 2 Occupancies used for kindergarten, first- or second-grade pupils, and Division 3 Occupancies shall not be located above or below the first story.

EXCEPTIONS:

1. Basements or stories having floor levels located within 4 feet (1219 mm), measured vertically, from adjacent ground level at the point of exit discharge, provided the basement or story has exterior exit doors at that level.
2. In buildings equipped with an automatic sprinkler system throughout, rooms used for kindergarten, first- and second-grade children or for day-care purposes may be located on the second story, provided there are at least two exit doors into separate means of egress systems as defined in Section 1007.3.
3. Division 3 Occupancies may be located above the first story in buildings of Type I construction and in Types II-FR., II One-hour and III One-hour construction, subject to the limitation of Section 506 when:
 - 3.1 Division 3 Occupancies containing more than 12 children per story shall not be located above the fourth floor; and
 - 3.2 The entire story in which the day-care facility is located is equipped with an approved manual fire alarm and smoke-detection system. (See the Fire Code.) Actuation of an initiating device shall sound an audible alarm throughout the entire story. When a building fire alarm system is required by other provisions of this code or the Fire Code, the alarm system shall be connected to the building alarm system. An approved alarm signal shall sound at an approved location in the day-care occupancy to indicate a fire

[Title 51 WAC—p. 139]

alarm or sprinkler flow condition in other portions of the building; and

3.3 The day-care facility, if more than 1,000 square feet (92.9 m²) in area, is divided into at least two compartments of approximately the same size by a smoke barrier with door openings protected by smoke- and draft-control assemblies having a fire-protection rating of not less than 20 minutes. Smoke barriers shall have a fire-resistive rating of not less than one hour. In addition to the requirements of Section 302, occupancy separations between Division 3 Occupancies and other occupancies shall be constructed as smoke barriers. Door openings in the smoke barrier shall be tightfitting with gaskets installed as required by Section 1005, and shall be automatic closing by actuation of the automatic sprinklers, fire alarm or smoke-detection system. Openings for ducts and other heating, ventilating and air-conditioning openings shall be equipped with a minimum Class I, 250°F (121°C) smoke damper as defined and tested in accordance with approved recognized standards. See Chapter 35, Part IV. The damper shall close upon detection of smoke by an approved smoke detector located within the duct, or upon the activation of the fire alarm system; and

3.4 Each compartment formed by the smoke barrier has not less than two exits or exit-access doors, one of which is permitted to pass through the adjoining compartment; and

3.5 At least one exit or exit-access door from the Division 3 Occupancy shall be into a separate means of egress as defined in Section 1007.3; and

3.6 The building is equipped with an automatic sprinkler system throughout.

Stages and platforms shall be constructed in accordance with Chapter 4. For attic space partitions and draft stops, see Section 708.

305.5 Light, Ventilation and Sanitation. In Group E Occupancies, light, ventilation and sanitation shall be as specified in Chapters 12 and 29.

[Statutory Authority: RCW 19.27.031 and 19.27.074. 98-02-054, § 51-40-0305, filed 1/6/98, effective 7/1/98.]

WAC 51-40-0307 Section 307—Requirements for Group H Occupancies.

307.5 Light, Ventilation and Sanitation. In Group H Occupancies, light, ventilation and sanitation shall be as specified in Chapters 12 and 29.

307.5.1 is not adopted.

307.5.2 is not adopted.

307.5.3 is not adopted.

307.5.4 is not adopted.

[Statutory Authority: RCW 19.27.031 and 19.27.074. 98-02-054, § 51-40-0307, filed 1/6/98, effective 7/1/98.]

WAC 51-40-0308 Section 308—Requirements for Group I Occupancies.

308.5 Light, Ventilation and Sanitation. In Group I Occupancies, light, ventilation and sanitation shall be as specified in Chapters 12 and 29.

308.5.1 is not adopted.

308.5.2 is not adopted.

[Title 51 WAC—p. 140]

[Statutory Authority: RCW 19.27.031 and 19.27.074. 98-02-054, § 51-40-0308, filed 1/6/98, effective 7/1/98.]

WAC 51-40-0310 Section 310—Requirements for Group R Occupancies.

310.1 Group R Occupancies Defined. Group R Occupancies shall be:

Division 1. Hotels and apartment houses.

Congregate residences (each accommodating more than 10 persons).

Division 2. Not used.

Division 3. Dwellings, family child day care homes, adult family homes and lodging houses.

Congregate residences (each accommodating 10 persons or less).

Foster Family Care Homes licensed by the Washington State Department of Social and Health Services shall be permitted, as an accessory use to a dwelling unit, for six or fewer children including those of the resident family.

For occupancy separations, see Table 3-B.

A complete code for construction of detached one- and two-family dwellings is in Appendix Chapter 3, Division III, of this code. When adopted, as set forth in Section 101.3, it will take precedence over the other requirements set forth in this code.

310.2.2 Special provisions. Walls and floors separating dwelling units in the same building, or guest rooms in Group R, Division 1 Hotel Occupancies, shall not be of less than one-hour fire-resistive construction.

Group R, Division 1 Occupancies more than two stories in height or having more than 3,000 square feet (279 m²) of floor area above the first story shall not be of less than one-hour fire-resistive construction throughout, except as provided in Section 601.5.2.2.

Storage or laundry rooms that are within Group R, Division 1 Occupancies that are used in common by tenants shall be separated from the rest of the building by not less than one-hour fire-resistive occupancy separation. The separation between individual storage lockers may be nonrated in rooms of 500 square feet (46.4 m²) or less in area and in sprinklered rooms of any size.

For Group R, Division 1 Occupancies with a Group S, Division 3 parking garage in the basement or first story, see Section 311.2.2.

For attic space partitions and draft stops, see Section 708.

310.5 Light, Ventilation and Sanitation. In Group R Occupancies, light, ventilation and sanitation shall be as specified in Chapters 12 and 29.

310.6 Room Dimensions.

310.6.1 Ceiling heights. Habitable rooms, hallways, corridors, bathrooms, toilet rooms, laundry rooms and basements shall have a ceiling height of not less than 7 feet (2134 mm). The required height shall be measured from the finished floor to the lowest projection from the ceiling.

EXCEPTIONS:

1. Beams and girders spaced not less than 4 feet (1219 mm) on center may project not more than 6 inches (153 mm) below the required ceiling height.
2. Ceilings in basements without habitable spaces may project to within 6 feet 8 inches (2032 mm) of the finished floor, and beams, girders, ducts or other obstructions may project to within 6 feet 4 inches (1931 mm) of the finished floor.
3. Not more than 50 percent of the required floor area of a room or space is permitted to have a sloped ceiling less than 7 feet (2134 mm) in height, with no portion of the required floor area less than 5 feet (1524 mm) in height.

310.6.2 Floor area. Dwelling units and congregate residences shall have at least one room that shall have not less than 120 square feet (11.2 m²) of floor area. Other habitable rooms except kitchens shall have an area of not less than 70 square feet (6.5 m²). Efficiency dwelling units shall comply with the requirements of Section 310.7.

Portions of a room with a sloped ceiling measuring less than 5 feet (1524 mm) or a flat ceiling measuring less than 7 feet (2134 mm) from the finished floor to the finished ceiling shall not be considered as contributing to the minimum habitable area for that room.

310.6.3 Width. Habitable rooms other than a kitchen shall not be less than 7 feet (2134 mm) in any dimension.

310.9.1.6. Location within family child day care homes. In family child day care homes operable detectors shall be located in all sleeping and napping areas. When the family child day care home has more than one story, and in family child day care homes with basements, an operable detector shall be installed on each story and in the basement. In family child day care homes where a story or basement is split into two or more levels, the smoke detector shall be installed in the upper level, except that when the lower level contains a sleeping or napping area, an operable detector shall be located on each level. When sleeping rooms are on an upper level, the detector shall be placed at the ceiling of the upper level in close proximity to the stairway. In family child day care homes where the ceiling height of a room open to the hallway serving the bedrooms exceeds that of the hallway by 24 inches or more, smoke detectors shall be installed in the hallway and the adjacent room. Detectors shall sound an alarm audible in all areas of the building.

310.13 Family Child Day Care Homes. For family child day care homes with more than six children, each floor level used for family child day care purposes shall be served by two remote means of egress. Exterior exit doors shall be operable from the inside without the use of keys or any special knowledge or effort.

Basements located more than four feet below grade level shall not be used for family child day care homes unless one of following conditions exist:

1. Stairways from the basement open directly to the exterior of the building without entering the first floor; or

2. One of the two required means of egress discharges directly to the exterior from the basement level, and a self closing door is installed at the top or bottom of the interior stair leading to the floor above; or

3. One of the two required means of egress is an operable window or door, approved for emergency escape or rescue, that opens directly to a public street, public alley, yard or exit court; or

4. A residential sprinkler system is provided throughout the entire building in accordance with National Fire Protection Association Standard 13d.

Floors located more than 4 feet above grade level shall not be occupied by children in family day care homes.

EXCEPTIONS:

1. Use of toilet facilities while under supervision of an adult staff person.
2. Family child day care homes may be allowed on the second story if one of the following conditions exists:
 - 2.1 Stairways from the second story open directly to the exterior of the building without entering the first floor; or
 - 2.2 One of the two required means of egress discharges directly to the exterior from the second story level, and a self closing door is installed at the top or bottom of the interior stair leading to the floor below; or
 - 2.3 A residential sprinkler system is provided throughout the entire building in accordance with National Fire Protection Association Standard 13d.

Every sleeping or napping room in a family child day care home shall have at least one operable window for emergency rescue.

EXCEPTION: Sleeping or napping rooms having doors leading to two separate means of egress, or a door leading directly to the exterior of the building.

Rooms or spaces containing a commercial-type cooking kitchen, boiler, maintenance shop, janitor closet, laundry, woodworking shop, flammable or combustible storage, or painting operation shall be separated from the family child day care area by at least one-hour fire-resistive construction.

EXCEPTION: A fire-resistive separation shall not be required where the food preparation kitchen contains only a domestic cooking range, and preparation of food does not result in the production of smoke or grease laden vapors.

310.14 Adult Family Homes.

310.14.1 General. This section shall apply to all newly constructed adult family homes and all existing single family homes being converted to adult family homes. This section shall not apply to those adult family homes licensed by the State of Washington Department of Social and Health Services prior to July 1, 2001.

310.14.2 Submittal Standards. In addition to those requirements in Section 106.3, the submittal shall identify the project as a Group R, Division 3 Adult Family Home Occupancy. A floor plan shall be submitted identifying the means of egress and the components in the means of egress such as stairs, ramps, platform lifts and elevators. The plans shall indicate the rooms used for clients and the sleeping room classification of each room.

310.14.3 Sleeping Room Classification. Each sleeping room in an adult family home shall be classified as:

1. Type S - where the means of egress contains stairs, elevators or platform lifts.

2. Type NS1 - where one means of egress is at grade level or a ramp to grade is provided which is constructed in accordance with 1106.8.

3. Type NS2 - where two means of egress are at grade level or ramps to grade are provided which are constructed in accordance with 1106.8.

310.14.4 Types of Locking Devices. All bedroom and bathroom doors shall be openable from the outside when locked.

Every closet shall be readily openable from the inside.

310.14.5 Smoke Alarm Requirements. All adult family homes shall be equipped with smoke alarms installed as required in Section 310.9.1. Alarms shall be installed in such a manner so that the fire warning may be audible in all parts of the dwelling upon activation of a single device.

310.14.6 Escape Windows and Doors. Every sleeping room shall be provided with emergency escape and rescue windows as required by Section 310.4.

310.14.7 Fire Apparatus Access Roads and Water Supply for Fire Protection. Adult family homes shall be served by fire apparatus access roads and water supplies meeting the requirements Article 9 of the Fire Code for new construction.

[Statutory Authority: RCW 19.27.031, 19.27.074, 01-02-095, § 51-40-0310, filed 1/3/01, effective 7/1/01; 98-02-054, § 51-40-0310, filed 1/6/98, effective 7/1/98.]

WAC 51-40-0311 Section 311—Requirements for Group S Occupancies.

311.5 Light, Ventilation and Sanitation. In Group S Occupancies, light, ventilation and sanitation shall be as specified in Chapters 12 and 29.

311.5.1 is not adopted.

311.5.2 is not adopted.

[Statutory Authority: RCW 19.27.031 and 19.27.074, 98-02-054, § 51-40-0311, filed 1/6/98, effective 7/1/98.]

WAC 51-40-0313 Section 313—Requirements for Group LC Occupancies.

313.1 Group LC Occupancies Defined. Group LC Occupancies shall include buildings, structures, or portions thereof, used for the business of providing licensed care to clients in one of the following categories regulated by either the Washington Department of Health or the Department of Social and Health Services:

1. Adult residential rehabilitation facility.
2. Alcoholism intensive inpatient treatment service.
3. Alcoholism detoxification service.

4. Alcoholism long term treatment service.

5. Alcoholism recovery house service.

6. Boarding home.

7. Group care facility.

8. Group care facility for severely and multiple handicapped children.

9. Residential treatment facility for psychiatrically impaired children and youth.

EXCEPTION: Where the care provided at an alcoholism detoxification service is acute care similar to that provided in a hospital, the facility shall be classified as a Group I, Division 1.1 hospital.

313.2 Construction, Height and Allowable Area.

313.2.1 General. Buildings or parts of buildings classed in Group LC because of the use or character of the occupancy shall be limited to the types of construction set forth in this section.

313.2.1.1 Type of construction. Except as provided herein, LC Occupancy buildings may be of any construction type allowed in this code and shall not exceed the limits specified in Sections 504, 505 and 506.

Group LC Occupancies which are licensed for more than six clients and which are more than two stories in height or which have more than 3,000 square feet (279 m²) above the first story shall not be less than one-hour fire-resistive construction throughout.

EXCEPTION: Buildings which are licensed for not more than 16 clients may be of Type V-N construction provided:

1. The entire building has an interior wall and ceiling covering consisting of 1/2 inch gypsum wall board or an approved equal installed in accordance with Section 2511; and,
2. An approved smoke-detection system, supervised by an approved central, proprietary or remote station service, is installed throughout the entire structure and is interconnected with any required sprinkler system.

For attic space partitions and draft stops, see Section 708.

313.2.1.2 Area and height. Buildings classified as Group LC Occupancy shall not exceed, in area or height, the limitations set forth in Table 5-B for Group R, Division 1 Occupancies.

EXCEPTION: LC Occupancies licensed for six or fewer clients may be of unlimited area provided they are limited to 3 stories or less.

313.2.1.3 Mixed Occupancies. Group LC Occupancies shall be separated from Group H Occupancies by a four-hour fire-resistive occupancy separation and shall be separated from all other occupancies by a one-hour fire-resistive assembly.

EXCEPTIONS:

1. An occupancy separation need not be provided between a Group LC Occupancy licensed for 16 or fewer clients and a carport having no enclosed use above, provided the carport is entirely open on two or more sides.
2. In a Group LC Occupancy licensed for 16 or fewer clients, the one-hour occupancy separation between a Group LC Occupancy and a Group U, Division 1 Occupancy, may be limited to the installation of materials approved for one-hour fire-resistive construction on the garage side and a self-closing, tight-fitting solid-wood door 1 3/8 inches (35 mm) in thickness, or

a self-closing tight-fitting door having a fire-protection rating of not less than 20 minutes when tested in accordance with Part II of UBC Standard 7-2, which is a part of this code, is permitted in lieu of a one-hour fire assembly. Fire dampers need not be installed in air ducts passing through the wall, floor or ceiling separating a Group LC Occupancy from a Group U Occupancy, provided such ducts within the Group U Occupancy are constructed of steel having a thickness not less than 0.019 inch (0.48 mm) (No. 26 galvanized sheet gage) and having no openings into the Group U Occupancy.

3. An occupancy separation need not be provided between a Group LC, Boarding Home Occupancy and a Group R, Division 1 Occupancy.

313.3 Location on Property. For fire-resistive protection of exterior walls and openings, as determined by location on property, see Section 503 and Chapter 6. For the purpose of this determination, LC Occupancies licensed for six or fewer clients shall comply with provisions for Group R, Division 3 Occupancies; and all other LC Occupancies shall comply with provisions for Group R, Division 1 Occupancies.

313.4 Access, Means of Egress, and Emergency Escape.

313.4.1 Evacuation capability. Evacuation capability is the ability of the clients of a licensed care facility to respond to an emergency situation and either evacuate a building or move to a point of safety. Clients shall be classified in one of the following levels:

- I - persons physically and mentally capable of walking or traversing a normal path to safety, including the ascent and descent of stairs, and capable of self-preservation, without the physical assistance of another person.
- II - persons physically and mentally capable of traversing a normal path to safety with the use of mobility aids, but unable to ascend or descend stairs without the physical assistance of another person.
- III - persons physically or mentally unable to walk or traverse a normal path to safety without the physical assistance of another person.

313.4.2 Means of egress. Means of egress shall be provided as specified in Chapter 10. For the purpose of determining egress requirements, Group LC Occupancies shall be considered to have an occupant load factor of 300. At least two means of egress shall be required when the number of occupants (clients and staff) is 10 or more. For all other requirements of Chapter 10, Group LC Occupancies licensed for six or fewer clients shall comply with provisions for Group R, Division 3 Occupancies; and all other Group LC Occupancies shall comply with provisions for Group R, Division 1 Occupancies.

EXCEPTIONS:

1. Means of egress illumination required by Section 1003.2.9.1 need not be provided in any Group LC Occupancy licensed for six or fewer clients.
2. In LC Occupancies with an approved automatic fire sprinkler system and approved automatic fire alarm system, waiting and resting areas may be open to the corridor provided:
 - 2.1 Each rest area does not exceed 150 square feet, excluding the corridor width; and
 - 2.2 Walls defining the space shall continue the construction of the corridor's wall; and
 - 2.3 The floor on which the rest area or areas are located is divided into at least two compartments by smoke barrier walls of not less than one-hour fire-

resistive construction meeting the requirements of Section 308.2.2.1 and Section 905.2.3; and

2.4 Combustible furnishings located within the rest area are flame resistant as defined by Uniform Fire Code Section 207; and

2.5 Emergency means of egress lighting is provided as required by Section 1003.2.9.1 to illuminate the area.

313.4.3 Accessibility. In new construction, Group LC Occupancies regardless of the number of clients shall comply with accessibility standards for Group R, Division 1 apartment buildings or congregate residences as specified in Chapter 11.

Where a Group LC Occupancy is being established by change of occupancy in an existing building, the building shall be altered to comply with apartment building or congregate residence provisions of Chapter 11 if any client is a person with disability. The alterations shall provide the minimum necessary access appropriate for the disabilities of clients. Any alteration, whether to accommodate a client with disability or for another purpose, shall comply with Part III of Chapter 11.

313.4.4 Emergency escape.

313.4.4.1 Location of sleeping rooms. In every licensed care facility, all sleeping rooms occupied by clients with an evacuation capability of II or III shall be located on a grade level floor which provides not less than two means of egress which do not require clients to use stairs, elevator, or platform lift to exit the facility.

EXCEPTIONS:

1. In a Group LC Occupancy licensed to provide care to two or fewer clients with an evacuation capability of II or III and six or fewer total clients, only one means of egress which does not require clients to use stairs, elevator or platform lift to exit the facility need be provided.
2. Sleeping rooms for clients with an evacuation capability of II or III may be located on floors other than at grade level, provided the facility is divided into at least two compartments by smoke barriers of not less than one-hour fire-resistance meeting the requirements of Sections 308.2.2.1 and 905.2.3.

313.4.4.2 Escape windows and doors. Every sleeping room below the fourth story (including basements) shall have at least one operable window or door approved for emergency escape or rescue which shall open directly into a public street, public alley, yard or exit court. The emergency window shall be operable from the inside to provide a full, clear opening without the use of separate tools.

EXCEPTION:

The window or door may open into an atrium complying with Section 402 provided the window or door opens onto an exit-access balcony and the sleeping room has an exit or exit-access doorway which does not open into the atrium.

Escape or rescue windows shall have a minimum net clear openable area of 5.7 square feet (0.53 m²). The minimum net clear openable height dimension shall be 24 inches (610 mm). The minimum net clear openable width dimension shall be 20 inches (508 mm). When windows are provided as a means of escape or rescue, they shall have a finished sill height not more than 44 inches (1118 mm) above the floor.

Escape and rescue windows with a finished sill height below the adjacent ground elevation shall have a window well. Window wells at escape and rescue windows shall comply with the following:

1. The clear horizontal dimension shall allow the window to be fully opened and provide a minimum accessible net clear opening of 9 square feet (0.84 m²), with a minimum dimension of 36 inches (914 mm).

2. Window wells with a vertical depth of more than 44 inches (1118 mm) shall be equipped with an approved permanently affixed ladder or stairs that are accessible with the window in the fully open position. The ladder or stairs shall not encroach into the required dimensions of the window well by more than 6 inches (152 mm).

Bars, grilles, grates or similar devices may be installed on emergency escape windows, doors or window wells, provided:

1. The devices are equipped with approved release mechanisms which are operable from the inside without the use of a key or special knowledge or effort; and

2. The building is equipped with smoke detectors installed in accordance with Section 313.8.

313.5 Light, Ventilation and Sanitation.

313.5.1 General. For the purpose of determining the light and ventilation for Group LC Occupancies required by this section, any room may be considered as a portion of an adjoining room when one half of the area of the common wall is open and unobstructed and provides an opening of not less than one tenth of the floor area of the interior room or 25 square feet (2.3 m²), whichever is greater.

Exterior openings for natural light or ventilation required by this section shall open directly onto a public way or a yard or court as set for in Section 313.5.4.

EXCEPTIONS:

1. Required exterior openings may open into a roofed porch where the porch:
 - 1.1 Abuts a public way, yard or court; and
 - 1.2 Has a ceiling height of not less than 7 feet (2134 mm); and
 - 1.3 Has a longer side at least 65 percent open and unobstructed.
2. Skylights.

313.5.2 Light. Sleeping rooms and habitable rooms within the licensed care facility shall be provided with natural light by means of exterior glazed openings with an area not less than one tenth of the floor area of such rooms with a minimum of 10 square feet (0.93 m²).

EXCEPTION: Kitchens may be provided with artificial light.

313.5.3 Ventilation. Group LC Occupancies shall comply with provisions for Group R Occupancies as provided in the Washington State Ventilation and Indoor Air Quality Code (WAC 51-13).

313.5.4 Yards and Courts.

313.5.4.1 General. This section shall apply to yards and courts adjacent to exterior openings that provide required light or ventilation. Such yards and courts shall be on the same property as the building.

313.5.4.2 Yards. Yards shall not be less than 3 feet (914 mm) in width for one-story and two-story buildings. For buildings more than two stories in height, the minimum width

of the yard shall be increased at the rate of 1 foot (305 mm) for each additional story. For buildings exceeding 14 stories in height, the required width of the yard shall be computed on the basis of 14 stories.

313.5.4.3 Courts. Courts shall not be less than 3 feet (914 mm) in width. Courts having windows opening on opposite sides shall not be less than 6 feet (1829 mm) in width. Courts bounded on three or more sides by the walls of the building shall not be less than 10 feet (3048 mm) in length unless bounded on one end by a public way or yard. For buildings more than two stories in height, the court shall be increased 1 foot (305 mm) in width and 2 feet (610 mm) in length for each additional story. For buildings exceeding 14 stories in height, the required dimensions shall be computed on the basis of 14 stories.

Adequate access shall be provided to the bottom of all courts for cleaning purposes. Every court more than two stories in height shall be provided with a horizontal air intake at the bottom not less than 10 square feet (0.93 m²) in area and leading to the exterior of the building unless abutting a yard or a public way. The construction of the air intake shall be as required for the court walls of the building but in no case less than one-hour fire resistive.

313.5.4.4 Eaves. Eaves over required windows shall extend no closer than 30 inches (762 mm) from the side and rear property lines. See also Sections 503.2 and 705.

313.5.5 Sanitation.

313.5.5.1 General. Sanitation facilities shall comply with Chapter 29 and the provisions of this section. Any room in which a water closet is located shall be separated from food preparation or storage rooms by a self-closing tight-fitting door.

313.5.5.2 Group LC Occupancies with six or fewer clients. Group LC Occupancies licensed for six or fewer clients shall be provided with not less than one water closet, one lavatory and one bathtub or shower.

313.5.5.3 Group LC Occupancies with more than six clients. Group LC Occupancies licensed for more than six clients shall provide not less than one water closet for each 10 male clients, or fractional part thereof, and not less than one water closet for each 8 female clients, or fractional part thereof.

In addition, not less than one lavatory shall be provided for each 12 male clients, or fractional part thereof, and not less than one lavatory for each 12 female clients, or fractional part thereof. Where the number of clients of either sex exceeds 12, one lavatory shall be added for each additional 20 males, or fractional part thereof, and one lavatory shall be added for each additional 15 females, or fractional part thereof.

In addition, not less than one bathtub or shower shall be provided for every eight clients, or fractional part thereof. Where there are female clients, one additional bathtub or shower shall be provided for each 30 female clients, or fractional part thereof. Where the number of total clients exceeds

150, one bathtub or shower shall be provided for each 20 clients, or fractional part thereof, over 150 clients.

313.6 Room Dimensions.

313.6.1 Ceiling Heights. Habitable rooms, hallways, corridors, bathrooms, toilet rooms, laundry rooms and basements shall have a ceiling height of not less than 7 feet (2134 mm). The required height shall be measured from the finished floor to the lowest projection from the ceiling.

EXCEPTIONS:

1. Beams and girders spaced not less than 4 feet (1219 mm) on center may project not more than 6 inches (153 mm) below the required ceiling height.
2. Ceilings in basements without habitable spaces may project to within 6 feet 8 inches (2032 mm) of the finished floor, and beams, girders, ducts or other obstructions may project to within 6 feet 4 inches (1931 mm) of the finished floor.
3. Not more than 50 percent of the required floor area of a room or space is permitted to have a sloped ceiling less than 7 feet (2134 mm) in height, with no portion of the required floor area less than 5 feet (1524 mm) in height.

313.6.2 Floor area. Group LC Occupancies shall have at least one room which shall have not less than 120 square feet (11.2 m²) of floor area. Other habitable rooms except kitchens shall have an area of not less than 70 square feet (6.5 m²).

Portions of a room with a sloped ceiling measuring less than 5 feet (1524 mm) or a flat ceiling measuring less than 7 feet (2134 mm) from the finished floor to the finished ceiling shall not be considered as contributing to the minimum habitable area for that room.

313.6.3 Width. Habitable rooms other than kitchens shall not be less than 7 feet (2134 mm) in any dimension.

313.7 Shaft and Exit Enclosures. Exits shall be enclosed as specified in Chapter 10.

Elevator shafts, vent shafts, dumbwaiter shafts, clothes chutes and other vertical openings shall be enclosed and the enclosure shall be as specified in Section 711.

313.8 Smoke Detectors and Sprinkler Systems.

313.8.1 Smoke detectors.

313.8.1.1 General. Rooms within licensed care facilities that are used for sleeping purposes shall be provided with smoke detectors. Detectors shall be installed in accordance with the approved manufacturer's instructions.

313.8.1.2 Additions, alterations or repairs. When the valuation of an addition, alteration or repair to a Group LC Occupancy exceeds \$1,000 and a permit is required, or when one or more sleeping rooms is added or created in an existing Group LC Occupancy, smoke detectors shall be installed in accordance with Sections 313.8.1.3 and 313.8.1.4 of this section.

EXCEPTION: Repairs to the exterior surfaces are exempt from the requirements of this section.

313.8.1.3 Power source. In new construction, required smoke detectors shall receive their primary power from the building wiring when such wiring is served from a commercial source and shall be equipped with a battery backup. The

detector shall emit a signal when the batteries are low. Wiring shall be permanent and without a disconnecting switch other than those required for overcurrent protection. Smoke detectors may be solely battery operated when installed in existing buildings; or in buildings without commercial power; or in buildings which undergo alterations, repairs or additions regulated by Section 313.8.1.2.

313.8.1.4 Location. A detector shall be installed in each sleeping room and at a point centrally located in the corridor or area giving access to each separate sleeping area. When the licensed care facility has more than one story or in facilities with basements, a detector shall be installed on each story and in the basement. Where a story or basement is split into two or more levels, the smoke detector shall be installed on the upper level, except that when the lower level contains a sleeping area, a detector shall be installed on each level. When sleeping rooms are on an upper level, the detector shall be placed at the ceiling of the upper level in close proximity to the stairway. Where the ceiling height of a room open to a hallway serving the bedrooms exceeds that of the hallway by 24 inches (610 mm) or more, smoke detectors shall be installed in the hallway and in the adjacent room. Detectors shall sound an alarm audible in all sleeping areas of the licensed care facility in which they are located.

313.8.2 Sprinkler and standpipe systems.

313.8.2.1 Sprinkler Systems. An automatic sprinkler system shall be installed throughout every licensed care facility three or more stories in height or licensed for more than 16 clients. Licensed care facilities with 16 or fewer clients, licensed to provide care for more than two clients who have an evacuation capability of II or III, shall be provided with an automatic sprinkler system throughout the facility.

EXCEPTION: An automatic sprinkler system need not be installed in any licensed care facility licensed for six or fewer clients regardless of the level of evacuation capability.

Where a sprinkler system is required, a system complying with UBC Standard 9-1 shall be installed.

EXCEPTIONS:

1. An automatic sprinkler system complying with UBC Standard 9-3 may be installed in buildings of four stories or less.
2. Where a Group LC Occupancy is being established by change of occupancy in an existing building not protected by a sprinkler system as is required above for buildings of new construction, an automatic sprinkler system complying with NFPA Standard 13d may be installed provided the care facility is licensed for not more than 16 clients.

Residential or quick-response heads shall be used in all sprinkler systems.

313.8.2.2 Standpipe systems. Standpipe systems shall be provided where required by Section 904.5.

313.9 Fire Alarm Systems. Group LC Occupancies licensed for more than 16 clients shall be provided with an approved manual and automatic fire alarm system. The local alarm shall provide an alarm signal with a sound pressure level of 15 dBA above the average ambient sound level in every occupied space within the building. The minimum sound pressure level shall be 70 dBA. The maximum sound pres-

sure level shall not exceed 110 dBA at the minimum hearing distance from the audible appliance.

313.10 Heating. Licensed care facilities shall be provided with heating facilities capable of maintaining a room temperature of 70°F (21°C) at a point 3 feet (914 mm) above the floor in all habitable rooms.

313.11 Special Hazards. Chimneys and heating apparatus shall conform to the requirements of Chapter 31 and the Mechanical Code.

In Group LC Occupancies licensed for more than six clients, the storage, use and handling of flammable and combustible liquids shall be in accordance with the Fire Code. In such facilities, doors leading into rooms in which Class I flammable liquids are stored or used shall be protected by a fire assembly having a one-hour fire-protection rating. Such fire assembly shall be self-closing and shall be posted with a sign on each side of the door in 1-inch (25.4 mm) block letters stating: FIRE DOOR—KEEP CLOSED.

In Group LC Occupancies licensed for more than 16 clients, rooms containing a boiler, central heating plant or hot-water supply boiler shall be separated from the rest of the building by not less than a one-hour occupancy separation.

[Statutory Authority: RCW 19.27.031, 19.27.074, 01-02-095, § 51-40-0313, filed 1/3/01, effective 7/1/01; 98-02-054, § 51-40-0313, filed 1/6/98, effective 7/1/98.]

WAC 51-40-0403 Section 403—Special provisions for Group B office buildings and Group R, Division 1 Occupancies.

403.6.1 General. A central control station room for fire department operations shall be provided. The location, size and arrangement of the central control station shall be approved by the authority having jurisdiction. The central control station room shall be separated from the remainder of the building by not less than a one-hour fire-resistive occupancy separation. It shall contain the following as a minimum:

1. The voice alarm and public address system panels.
2. The fire department communications panel.
3. Fire-detection and alarm systems annunciator panels.
4. Annunciator visually indicating the location of the elevators and whether they are operational.
5. Status indicators and controls for air-handling systems.
6. Controls for unlocking all stairway doors simultaneously.
7. Sprinkler valve and water-flow detector display panels.
8. Emergency and standby power status indicators.
9. A telephone for fire department use with controlled access to the public telephone system.

[Title 51 WAC—p. 146]

10. Fire pump status indicators.

11. Schematic building plans indicating the typical floor plan and detailing the building core, means of egress, fire-protection systems, fire fighting equipment and fire department access.

12. Work table.

403.7 Elevators. Elevators and elevator lobbies shall comply with the provisions of Chapter 30 and the following:

Note: A bank of elevators is a group of elevators or a single elevator controlled by a common operating system; that is, all those elevators that respond to a single call button constitute a bank of elevators. There is no limit on the number of cars that may be in a bank or group, but there may not be more than four cars within a common hoistway.

1. Elevators on all floors shall open into elevator lobbies that are separated from the remainder of the building, including corridors and other means of egress, by walls extending from the floor to the underside of the fire-resistive floor or roof above. Such walls shall not be of less than one-hour fire-resistive construction. Openings through such walls shall conform to Section 1004.3.4.3.2.

EXCEPTIONS:

1. The main entrance-level elevator lobby in office buildings.
2. Elevator lobbies located within an atrium complying with the provisions of Section 402.
3. In fully sprinklered office buildings, corridors may lead through enclosed elevator lobbies if all areas of the building have access to at least one required means of egress without passing through the elevator lobby.
4. Where elevator shafts are pressurized in accordance with Section 905, elevator lobbies need not be provided.

2. Each elevator lobby shall be provided with approved smoke detector(s) installed in accordance with their listings. When the detector is activated, elevator doors shall not open and all cars serving that lobby are to return to the main floor and be under manual control only. If the main floor detector or a transfer floor detector is activated, all cars serving the main floor or transfer floor shall return to a location approved by the fire department and building official and be under manual control only. The detector may serve to close the lobby doors, additional doors at the hoistway opening allowed in Section 3007 and smoke dampers serving the lobby.

3. Elevator hoistways shall not be vented through an elevator machine room. Each elevator machine room shall be treated as a separate smoke-control zone.

[Statutory Authority: RCW 19.27.031, 19.27.074, 03-01-055, § 51-40-0403, filed 12/11/02, effective 7/1/03; 98-02-054, § 51-40-0403, filed 1/6/98, effective 7/1/98.]

WAC 51-40-0405 Section 405—Stages and platforms.

405.3.3.2 Roof vents. Two or more vents shall be located near the center of and above the highest part of the stage area. They shall be raised above the roof and provide a net free vent area equal to 5 percent of the stage area. Vents shall be constructed to open automatically by approved heat-activated devices. Supplemental means shall be provided for manual

(2003 Ed.)

operation of the ventilator from the stage floor. Vents shall be labeled by an approved agency.

[Statutory Authority: RCW 19.27.031 and 19.27.074. 98-02-054, § 51-40-0405, filed 1/6/98, effective 7/1/98.]

WAC 51-40-0510 Section 510—Heating.

510.1 Definitions. For the purposes of this section only, the following definitions apply.

DESIGNATED AREAS are those areas designated by a county to be an urban growth area in chapter 36.70A RCW and those areas designated by the U.S. Environmental Protection Agency as being in nonattainment for particulate matter.

SUBSTANTIALLY REMODELED means any alteration or restoration of a building exceeding 60 percent of the appraised value of such building within a 12 month period. For the purpose of this chapter, the appraised value is the value as defined in Section 223 of the Uniform Building Code.

510.2 Primary Heating Source. Primary heating sources in all new and substantially remodeled buildings in designated areas, shall not be dependent upon wood stoves.

510.3 Solid Fuel Burning Devices. No used solid fuel burning device shall be installed in new or existing buildings unless such device is United States Environmental Protection Agency certified or a pellet stove either certified or exempt from certification by the United States Environmental Protection Agency.

EXCEPTION: Antique wood cook stoves and heaters manufactured prior to 1940.

[Statutory Authority: RCW 19.27.031 and 19.27.074. 98-02-054, § 51-40-0510, filed 1/6/98, effective 7/1/98.]

WAC 51-40-0804 Section 804—Maximum allowable flame spread.

804.1 General. The maximum flame-spread class of finish materials used on interior walls and ceilings shall not exceed that set forth in Table 8-B.

EXCEPTIONS:

1. Except in Group I Occupancies and in enclosed vertical exits, Class III may be used in other means of egress and rooms as wainscoting extending not more than 48 inches (1219 mm) above the floor and for tack and bulletin boards covering not more than 5 percent of the gross wall area of the room.
2. In other than Group I, Division 1.1, 1.2 or 2 suites complying with Section 1007.5, when a sprinkler system complying with UBC Standard 9-1 or 9-3 is provided, the flame-spread classification rating may be reduced one classification, but in no case shall materials having a classification greater than Class III be used.
3. The exposed faces of Type IV-H.T., structural members and Type IV-H.T., decking and planking, where otherwise permissible under this code, are excluded from flame-spread requirements.

[Statutory Authority: RCW 19.27.031 and 19.27.074. 98-02-054, § 51-40-0804, filed 1/6/98, effective 7/1/98.]

WAC 51-40-0902 Section 902—Standards of quality.

Fire-extinguishing systems, including automatic sprinkler systems, Class I, Class II and Class III standpipe systems,

(2003 Ed.)

special automatic extinguishing systems, basement pipe inlets, smoke-control systems, and smoke and heat vents shall be approved and shall be subject to such periodic tests as may be required.

The standards listed below labeled a "UBC Standard" are also listed in Chapter 35, Part II, and are part of this code. The other standards listed below are recognized standards (see Sections 3503 and 3504).

1. Fire-extinguishing system.

- 1.1 UBC Standard 9-1, Installation of Sprinkler Systems
- 1.2 UBC Standard 9-3, Installation of Sprinkler Systems in Group R Occupancies Four Stories or Less
- 1.3 NFPA Standard 13D, as published by the National Fire Protection Association, 1999 edition

2. Standpipe systems.

UBC Standard 9-2, Standpipe Systems

3. Smoke control.

- 3.1 UBC Standard 7-2, Fire Test of Door Assemblies
- 3.2 UL 555, Fire Dampers
- 3.3 UL 555C, Ceiling Dampers
- 3.4 UL 555S, Leakage Rated Dampers for Use in Smoke Control Systems
- 3.5 UL 33, Heat Response Links for Fire Protection Service
- 3.6 UL 353, Limit Controls

4. Smoke and heat vents.

UBC Standard 15-7, Automatic Smoke and Heat Vents

[Statutory Authority: RCW 19.27.031, 19.27.074. 01-02-095, § 51-40-0902, filed 1/3/01, effective 7/1/01; 98-02-054, § 51-40-0902, filed 1/6/98, effective 7/1/98.]

WAC 51-40-0904 Section 904—Fire-extinguishing systems.

904.1.2 Standards. Fire-extinguishing systems shall comply with UBC Standards 9-1 and 9-2.

EXCEPTIONS:

1. Automatic fire-extinguishing systems not covered by UBC Standard 9-1 or 9-2 shall be approved and installed in accordance with approved standards.
2. Automatic sprinkler systems may be connected to the domestic water-supply main when approved by the building official, provided the domestic water supply is of adequate pressure, capacity and sizing for the combined domestic and sprinkler requirements. In such case, the sprinkler system connection shall be made between the public water main or meter and the building shutoff valve, and there shall not be intervening valves or connections. The fire department connection may be omitted when approved by the fire department.
3. Automatic sprinkler systems in Group R Occupancies four stories or less may be in accordance with UBC Standard 9-3.
4. Sprinklers are not required at the top of noncombustible hoistways of passenger elevators whose car enclosure materials meet the requirements of ASME A17.1, Safety Code for Elevators and Escalators.

904.2.2 All occupancies except Group R, Division 3 and Group U Occupancies. Except for Group R, Division 3 and Group U Occupancies, an automatic sprinkler system shall be installed:

1. In every story or basement of all buildings when the floor area exceeds 1,500 square feet (139.4 m²) and there is

[Title 51 WAC—p. 147]

not provided at least 20 square feet (1.86 m²) of opening entirely above the adjoining ground level in each 50 lineal feet (15 240 mm) or fraction thereof of exterior wall in the story or basement on at least one side of the building. Openings shall have a minimum dimension of not less than 30 inches (762 mm). Such openings shall be accessible to the fire department from the exterior and shall not be obstructed in a manner that fire fighting or rescue cannot be accomplished from the exterior.

When openings in a story are provided on only one side and the opposite wall of such story is more than 75 feet (22 860 mm) from such openings, the story shall be provided with an approved automatic sprinkler system, or openings as specified above shall be provided on at least two sides of an exterior wall of the story.

If any portion of a basement is located more than 75 feet (22 860 mm) from openings required in this section, the basement shall be provided with an approved automatic sprinkler system.

2. At the top of rubbish and linen chutes and in their terminal rooms. Chutes extending through three or more floors shall have additional sprinkler heads installed within such chutes at alternate floors. Sprinkler heads shall be accessible for servicing.

3. In rooms where nitrate film is stored or handled.

4. In protected combustible fiber storage vaults as defined in the Fire Code.

5. Throughout all buildings with a floor used for human occupancy that is located 75 feet (22 860 mm) or more above the lowest level of fire department vehicle access.

EXCEPTIONS:

1. Airport control towers.
2. Open parking structures.
3. Group F, Division 2 Occupancies.

904.2.4.1 General (Group E Occupancies). An automatic fire-extinguishing system shall be installed in all newly constructed buildings classified as Group E, Division 1 Occupancy. A minimum water supply meeting the requirements of UBC Standard 9-1 shall be required. The chief of the fire department may reduce fire flow requirements for buildings protected by an approved automatic sprinkler system.

For the purpose of this section, additions exceeding 60 percent of the value of such building or structure, or alterations and repairs to any portion of a building or structure within a twelve-month period that exceeds 100 percent of the value of such building or structure shall be considered new construction. In the case of additions, area separation walls shall define separate buildings.

EXCEPTION:

Portable school classrooms, provided:

1. Aggregate area of clusters of portable school classrooms does not exceed 5,000 square feet (465 m²); and
2. Clusters of portable school classrooms shall be separated as required in Chapter 5.

When not required by other provisions of this chapter, a fire-extinguishing system installed in accordance with UBC Standard 9-1 may be used for increases and substitutions allowed in Sections 505, 506, and 508.

[Statutory Authority: RCW 19.27.031 and 19.27.074. 98-02-054, § 51-40-0904, filed 1/6/98, effective 7/1/98.]

WAC 51-40-0905 Section 905—Smoke control.

905.2.1 General. Buildings or portions thereof required by this code to have a smoke-control system shall have such systems designed in accordance with the requirements of this section.

EXCEPTIONS:

1. Smoke and heat venting required by Section 906.
2. Where elevator shaft pressurization is required to comply with Exception 4 of Section 403.7 item 1 or Exception 4 of Section 1004.3.4.5, the pressurization system shall comply with the following:
 - 2.1. Elevator shafts shall be pressurized to not less than 0.10 inch of water column relative to atmospheric pressure. Elevator pressurization shall be measured with elevator cars at the designated primary recall level with the doors in the open position. The test shall be conducted at the location of the calculated maximum positive stack effect in the elevator shaft. The measured pressure shall be sufficient to provide 0.10 inch of water column as well as accounting for the stack and wind effect expected on the mean low temperature January day.
 - 2.2. The elevator shaft pressurization shall be activated by a fire alarm system which shall include smoke detectors or other approved detectors located near the elevator shaft on each floor as approved by the building official and the fire chief. If the building has a fire alarm panel, detectors shall be connected to, with power supplied by, the fire alarm panel.
 - 2.3. Elevator shaft pressurization equipment and its ductwork located within the building shall be separated from other portions of the building by construction equal to that required for the elevator shaft.
 - 2.4. Elevator shaft pressurization air intakes shall be located in accordance with Section 905.7.4. Such intakes shall be provided with smoke detectors which upon detection of smoke, shall deactivate the pressurization fan supplied by that air intake.
 - 2.5. The power source for the fire alarm system and the elevator shaft pressurization system shall be in accordance with Section 905.8.
 - 2.6. Hoistway venting required by Section 3004 need not be provided for pressurized elevator shafts.
 - 2.7. Elevator machine rooms required to be pressurized by Section 3005.2 need not be pressurized where separated from the hoistway by shaft construction in accordance with Section 711.
 - 2.8. Special inspection shall be required in accordance with Section 905.15.9 and Section 1701.

[Statutory Authority: RCW 19.27.031, 19.27.074. 03-01-055, § 51-40-0905, filed 12/11/02, effective 7/1/03.]

WAC 51-40-1000 Chapter 10—Means of egress.

[Statutory Authority: RCW 19.27.031 and 19.27.074. 98-02-054, § 51-40-1000, filed 1/6/98, effective 7/1/98.]

WAC 51-40-1002 Definitions.

Smoke-Protected Assembly Seating is an assembly area wherein the roof is not less than 15 feet (4500 mm) above the highest cross aisle or seat row, and having smoke-actuated venting facilities within that part of the roof sufficient to maintain the level of smoke at least 6 feet (1830 mm) above the highest seat or walking level.

[Statutory Authority: RCW 19.27.031 and 19.27.074. 98-02-054, § 51-40-1002, filed 1/6/98, effective 7/1/98.]

WAC 51-40-1003 General egress requirements.

1003.3.1.1 General (Doors). For the purposes of Section 1003.3.1, the term "exit door" shall mean all of those doors or doorways along the path of exit travel anywhere in a means of egress system.

Exit doors serving the means of egress system shall comply with the requirements of Section 1003.3.1. Where additional doors are installed for egress purposes, they shall conform to all requirements of this section. Buildings or structures used for human occupancy shall have at least one exterior exit door that meets the requirements of Section 1003.3.1.3. Section 1003.3.1.5 shall apply to all exit doors within an accessible route, regardless of occupant load.

Exit doors shall be readily distinguishable from the adjacent construction and shall be easily recognizable as exit doors. Mirrors or similar reflecting materials shall not be used on exit doors, and exit doors shall not be concealed by curtains, drapes, decorations and similar materials.

1003.3.1.2 Special Doors. Revolving, sliding and overhead doors serving an occupant load of 10 or more shall not be used as required exit doors. Where revolving or overhead doors or turnstiles are used, an adjacent accessible gate or door shall be provided where an accessible route is required by Chapter 11.

EXCEPTIONS:

1. Approved revolving doors having leaves that will collapse under opposing pressures may be used, provided
 - 1.1 Such doors have a minimum width of 6 feet 6 inches (1981 mm).
 - 1.2 At least one conforming exit door is located adjacent to each revolving door.
 - 1.3 The revolving door shall not be considered to provide any required width when computing means of egress width in accordance with Section 1003.2.3.
2. Horizontal sliding doors complying with UBC Standard 7-8 may be used
 - 2.1 In elevator lobby separations.
 - 2.2 In other than Groups A and H Occupancies, where smoke barriers are required.
 - 2.3 In other than Group H Occupancies, where serving an occupant load of less than 50.

Power-operated doors complying with UBC Standard 10-1 may be used for egress purposes. Such doors, where swinging, shall have two guide rails installed on the swing side projecting out from the face of the door jambs for a distance not less than the widest door leaf. Guide rails shall not be less than 30 inches (762 mm) in height with solid or mesh panels to prevent penetration into door swing and shall be capable of resisting a horizontal load at top of rail of not less than 50 pounds per lineal foot (730 N/m).

EXCEPTIONS:

1. Walls or other types of separators may be used in lieu of the above guide rail, provided all the criteria are met.
2. Guide rails in industrial or commercial occupancies not accessible to the public may comply with the exception to Section 509.3.
3. Doors swinging toward flow of traffic shall not be permitted unless actuating devices start to function at least 8 feet 11 inches (2718 mm) beyond the door in an open position and guide rails extend 6 feet 5 inches (1956 mm) beyond the door in an open position.

Clearances for guide rails shall be as follows:

1. Six inches (152 mm) maximum between rails and leading edge of door at the closest point in its arc of travel.
2. Six inches (152 mm) maximum between rails and the door in an open position.
3. Two inches (51 mm) minimum between rail at hinge side and door in an open position.
4. Two inches (51 mm) maximum between freestanding rails and jamb or other adjacent surface.

1003.3.1.5 Swing and Opening Force. Exit doors serving an occupant load of 10 or more shall be of the pivoted, balanced or side-hinged swinging type. Exit doors shall swing in the direction of the path of exit travel where the area served has an occupant load of 50 or more. The door shall swing to the fully open position when an opening force not to exceed 30 pounds (133.45 N) is applied to the latch side. Within an accessible route, such force shall not exceed 8.5 pounds (37.8 N) at exterior doors; and shall not exceed 5 pounds (22.24 N) at sliding and folding doors and interior swinging doors. At exterior doors where environmental conditions require greater closing pressure, power-operated doors shall be used within the accessible route. For other door-opening forces, see Chapter 11 and Section 905.3. See Section 3207 for doors swinging over public property.

EXCEPTIONS:

1. Group I, Division 3 Occupancy used as a place of detention.
2. In other than accessible dwelling units, doors within or serving an individual dwelling unit.
3. Special door conforming with Section 1003.3.1.2.
4. The opening force at required fire doors within an accessible route may be not greater than 30 pounds (133.45 N).

Double-acting doors shall not be used as exits where any of the following conditions exist:

1. The occupant load served by the door is 100 or more.
2. The door is part of a fire assembly.
3. The door is part of a smoke- and draft-control assembly.
4. Panic hardware is required or provided on the door.

A double-acting door shall be provided with a view panel of not less than 200 square inches (0.129 m²).

1003.3.1.6 Floor Level at Doors. Regardless of the occupant load served, there shall be a floor or a landing on each side of a door. Where access for persons with disabilities is required by Chapter 11, the floor or landing shall not be more than 1/2 inch (13 mm) lower than the threshold of the doorway. Where such access is not required, the threshold shall not exceed 1 inch (25 mm). Landings shall be level except that exterior landings, may have a slope not to exceed 1/4 unit vertical in 12 units horizontal (2% slope).

EXCEPTIONS:

1. In Group R, Division 3, and Group U Occupancies and within individual units of Group R, Division 1 Occupancies:
 - 1.1. A door may open at the top of an interior flight of stairs, provided the door does not swing over the top step.
 - 1.2. A door may open at a landing which is not more than 8 inches (203 mm) lower than the floor level, provided the door does not swing over the landing.

- 1.3. Screen doors and storm doors may swing over stairs, steps or landings.
2. Doors serving building equipment rooms which are not normally occupied.
3. At exterior sliding doors within accessible dwelling units, the floor or landing may be no more than 3/4 inch (19 mm) lower than the threshold of the doorway, including the sliding door tracks, provided that an additional accessible entrance door is provided into the dwelling unit.

1003.3.1.10 Special Egress-control Devices. When approved by the building official, exit doors in Group B; Group F; Group I, Divisions 1.1, 1.2 and 2; Group M, Group LC Occupancies, and Group S Occupancies may be equipped with approved listed special egress-control devices, provided the building is protected throughout by an approved automatic sprinkler system and an approved automatic smoke-detection system. Such devices shall conform to all of the following:

1. The egress-control device shall automatically deactivate upon activation of either the sprinkler system or the smoke-detection system.
2. The egress-control device shall automatically deactivate upon loss of electrical power to any one of the following:
 - 2.1 The egress-control device itself.
 - 2.2 The smoke-detection system.
 - 2.3 Means of egress illumination as required by Section 1003.2.9.
3. The egress-control device shall be capable of being deactivated by a signal from a switch located in an approved location.
4. An irreversible process which will deactivate the egress-control device shall be initiated whenever a manual force of not more than 15 pounds (66.72 N) is applied for two seconds to the panic bar or other door-latching hardware. The egress-control device shall deactivate within an approved time period not to exceed a total of 15 seconds. The time delay established for each egress-control device shall not be field adjustable.
5. Actuation of the panic bar or other door-latching hardware shall activate an audible signal at the door.
6. The unlatching shall not require more than one operation.

A sign shall be provided on the door located above and within 12 inches (305 mm) of the panic bar or other door-latching hardware reading:

**KEEP PUSHING. THE DOOR WILL OPEN IN
SECONDS. ALARM WILL SOUND.**

Sign letter shall be at least 1 inch (25 mm) in height and shall have a stroke of not less than 1/8 inch (3.2 mm).

Regardless of the means of deactivation, relocking of the egress-control device shall be by manual means only at the door.

EXCEPTION: Subject to the approval of the building official, special units for the care of dementia patients in nursing

homes which are identified and approved by the state agency licensing such units, may use special egress-control devices where a panic bar is not part of the egress-control mechanism.

1003.3.3.1 General (Stairways).

Every stairway having two or more risers serving any building or portion thereof shall conform to the requirements of Section 1003.3.3. For the purposes of Section 1003.3.3, the term "stairway" shall include stairs, landings, handrails and guardrails as applicable. Where aisles in assembly rooms have steps, they shall conform with the requirements in Section 1004.3.2.

For the purpose of this chapter, the term "step" shall mean those portions of the means of egress achieving a change in elevation by means of a single riser. Individual steps shall comply with the detailed requirements of this chapter which specify applicability to steps.

EXCEPTIONS:

1. Stairs or ladders used only to attend equipment or window wells are exempt from the requirements of this section.
2. Stairs or ladders within an individual dwelling unit used to gain access to areas of 200 square feet (18.6 m²) or less, and not containing the primary bathroom or kitchen, are exempt from the requirements of this section.

Stairways located in a building required to be accessible shall also comply with Chapter 11.

1003.3.3.3 Rise and Run. The rise of steps and stairs shall not be less than 4 inches (102 mm) nor more than 7-1/2 inches (190 mm). The greatest riser height within any flight of stairs shall not exceed the smallest by more than 3/8 inch (9.5 mm). Except as permitted in Sections 1003.3.3.8.1, 1003.3.3.8.2 and 1003.3.3.8.3, the run shall not be less than 10 inches (254 mm), as measured horizontally between the vertical planes of the furthest projections of adjacent treads or nosings. Stair treads shall be of uniform size and shape, except the largest tread run within any flight of stairs shall not exceed the smallest by more than 3/8 inch (9.5 mm).

EXCEPTIONS:

1. Private steps and stairways serving an occupant load of less than 10 and stairways to unoccupied roofs may be constructed with an 8-inch-maximum (203 mm) rise and a 9-inch-minimum (229 mm) run.
2. Where the bottom or top riser adjoins a sloping public way, walk or driveway having an established grade and serving as a landing, the bottom or top riser may be reduced along the slope.

Where Exception 2 to Section 1103.2.2 is used in a building design, the run of stair treads shall not be less than 11 inches (279 mm), as measured horizontally between the vertical planes of the furthest projections of adjacent tread. The largest tread run within any flight of stairs shall not exceed the smallest by more than 3/8 inch (9.5 mm).

1003.3.3.6 Handrails. Stairways shall have handrails on each side, and every stairway required to be more than 88 inches (2235 mm) in width shall be provided with not less than one intermediate handrail for each 88 inches (2235 mm) of required width. Intermediate handrails shall be spaced approximately equally across the entire width of the stairway.

EXCEPTIONS:

1. Stairways less than 44 inches (1118 mm) in width or stairways serving one individual dwelling unit in Group R, Division 1 or 3 Occupancies or a Group R, Division 3 congregate residence may have one handrail. This exception shall not be used concurrently

with the second exception to the first paragraph of Section 1103.2.2.

2. Private stairways 30 inches (762 mm) or less in height may have handrails on one side only. This exception shall not be used concurrently with the second exception to the first paragraph of Section 1103.2.2.

3. Stairways having less than four risers and serving one individual dwelling unit in Group R, Division 1 or 3, or a Group R, Division 3 congregate residence or Group U Occupancies need not have handrails.

The top of handrails and handrail extensions shall be placed not less than 34 inches (864 mm) or more than 38 inches (965 mm) above landings and the nosing of treads. Handrails shall be continuous the full length of the stairs and, except for private stairways, at least one handrail shall extend in the direction of the stair run not less than 12 inches (305 mm) beyond the top riser nor less than a length equal to one tread depth plus 12 inches (305 mm) beyond the bottom riser. Ends shall be returned or shall terminate in newel posts or safety terminals.

EXCEPTIONS:

1. Private stairways do not require handrail extensions.
2. Handrails may have starting newel posts within the first tread on stairways in Group R, Division 3 Occupancies and within individual dwelling units of Group R, Division 1 Occupancies.

The handgrip portion of handrails shall not be less than 1/4 inches (32 mm) nor more than 2 inches (51 mm) in cross-sectional dimension or the shape shall provide an equivalent gripping surface. The handgrip portion of handrails shall have a smooth surface with no sharp corners. Handrails projecting from a wall shall have a space of not less than 1 1/2 inches (38 mm) between the wall and the handrail.

1003.3.3.13 Stairway Identification. Stairway identification signs shall be located at each floor level in all enclosed stairways in buildings four or more stories in height. The sign shall identify the stairway, indicate whether or not there is roof access, the floor level, and the upper and lower terminus of the stairway. The sign shall be located approximately 5 feet (1524 mm) above the landing floor in a position that is readily visible when the door is in either the open or closed position. Signs shall comply with requirements of U.B.C. Standard 10-2. Each door to a floor level also shall have a tactile sign, including raised letters and Braille, identifying the floor level and shall comply with Part II of Chapter 11.

1003.3.4.4 Landings (Ramps). Ramps having slopes steeper than 1 unit vertical in 15 units horizontal (6.7% slope) shall have landings at the top and bottom, and at least one intermediate landing shall be provided for each 5 feet (1524 mm) of vertical rise measured between the horizontal planes of adjacent landings. Landing shall have a dimension measured in the direction of ramp run of not less than 5 feet (1524 mm). Landings shall provide maneuvering clearances at doors as required in Chapter 11.

1003.3.4.5 Handrails (Ramps). Ramps having slopes steeper than 1 unit vertical in 15 units horizontal (6.7% slope) shall have handrails as required for stairways, except that intermediate handrails shall not be required. At least one handrail shall extend in the direction of ramp run not less than 12 inches (305 mm) horizontally beyond the top and bottom

of the ramp runs. Ramped aisles serving fixed seating shall have handrails as required in Section 1004.3.2.

[Statutory Authority: RCW 19.27.031, 19.27.074, 01-02-095, § 51-40-1003, filed 1/3/01, effective 7/1/01; 98-02-054, § 51-40-1003, filed 1/6/98, effective 7/1/98.]

WAC 51-40-1004 The exit access.

1004.3.2.3.1 Width. The clear width of aisles shall be based on the number of fixed seats served by the aisle. The required width of aisles serving fixed seats shall not be used for any other purpose.

The clear width of an aisle in inches shall not be less than the occupant load served by the aisle multiplied by 0.3 for aisles with slopes greater than 1 unit vertical to 8 units horizontal (12.5% slope) and not less than 0.2 for aisles with a slope of 1 unit vertical to 8 units horizontal (12.5% slope) or less. In addition, when the rise of steps in aisles exceeds 7 inches (178 mm), the aisle clear width shall be increased by 1/4 inches (32 mm) for each 100 occupants or fraction thereof served for each 1/4 inch (6.35 mm) of riser height above 7 inches (178 mm).

EXCEPTION:

For buildings with smoke-protected assembly seating and for which an approved life-safety evaluation is conducted, the minimum clear width of aisles and other means of egress may be in accordance with Table 10-D. For Table 10-D, the number of seats specified must be within a single assembly area, and interpolation shall be permitted between the specified values shown. If Table 10-D is used the minimum clear widths shown shall be modified in accordance with the following:

1. Where risers exceed 7 inches (178 mm) in height, multiply the stairway width in the tables by factor A, where:

$$A = 1 + \frac{(\text{riser height} - 7.0 \text{ inches})}{5} \quad (4-1)$$

For SI:

$$A = 1 + \frac{(\text{riser height} - 178 \text{ mm})}{127}$$

Where risers do not exceed 7 inches (178 mm) in height, A = 1.

2. Stairways not having a handrail within a 30-inch (762 mm) horizontal distance shall be 25 percent wider than otherwise calculated, i.e., multiply by B = 1.25. For all other stairs, B = 1.

3. Ramps steeper than 1 unit vertical in 10 units horizontal (10% slope) where used in ascent shall have their width increased by 10 percent, i.e., multiply by C = 1.10. For ramps not steeper than 1 unit vertical in 10 units horizontal (10% slope), C = 1. Where fixed seats are arranged in rows, the clear width of aisles shall not be less than set forth above or less than the following minimum widths:

- 3.1 Forty-eight inches (1219 mm) for stairways having seating on both sides.
- 3.2 Thirty-six inches (914 mm) for stairways having seating on one side.
- 3.3 Twenty-three inches (584 mm) between a stairway handrail and seating where the aisles are subdivided by the handrail.
- 3.4 Forty-two inches (1067 mm) for level or ramped aisles having seating on both sides.
- 3.5 Thirty-six inches (914 mm) for level or ramped aisles having seating on one side.
- 3.6 Twenty-three inches (584 mm) between a stairway handrail and seating where an aisle does not serve more than five rows on one side.

Where exit access is possible in two directions, the width of such aisles shall be uniform throughout their length.

Where aisles converge to form a single path of exit travel, the aisle width shall not be less than the combined required width of the converging aisles.

1004.3.2.5.2 Where required. Aisles with a slope steeper than 1 unit vertical in 8 units horizontal (12.5% slope) shall consist of a series of risers and treads extending across the entire width of the aisle, except as provided in Section 1004.3.2.6.

The height of risers shall not be more than 8 inches (203 mm) nor less than 4 inches (102 mm) and the tread run shall not be less than 11 inches (279 mm). The riser height shall be uniform within each flight and the tread run shall be uniform throughout the aisle. Variations in run or height between adjacent treads or risers shall not exceed 3/16 inch (4.8 mm).

EXCEPTION: Where the slope of aisle steps and the adjoining seating area is the same, the riser heights may be increased to a maximum of 9 inches (229 mm) and may be non-uniform, but only to the extent necessitated by changes in the slope of the adjoining seating area to maintain adequate sight lines. Variations may exceed 3/16 inch (4.8 mm) between adjacent risers, provided the exact location of such variations is identified with a marking stripe on each tread at the nosing or leading edge adjacent to the nonuniform riser. The marking stripe shall be distinctively different from the contrasting marking stripe.

A contrasting marking stripe or other approved marking shall be provided on each tread at the nosing or leading edge such that the location of each tread is readily apparent when viewed in descent. Such stripe shall be a minimum of 1 inch (25 mm) wide and a maximum of 2 inches (51 mm) wide.

EXCEPTION: The marking stripe may be omitted where tread surfaces are such that the location of each tread is readily apparent when viewed in descent.

1004.3.2.6 Ramp Slope. The slope of ramped aisles shall not be more than 1 unit vertical in 8 units horizontal (12.5% slope). Ramped aisles shall have a slip-resistant surface.

EXCEPTION: When provided with fixed seating, theaters may have a slope not steeper than 1 unit vertical in 5 units horizontal (20% slope).

1004.3.2.7 Handrails. Handrails shall comply with the height, size and shape dimensions set forth in Section 1003.3.3.6, and ends shall be returned or shall have rounded terminations or bends. Ramped aisles having a slope steeper than 1 unit vertical in 15 units horizontal (6.7% slope) and aisle stairs (two or more adjacent steps) shall have handrails located either at the side or within the aisle width. Handrails may project into the required aisle width a distance of 3 1/2 inches (89 mm).

EXCEPTIONS:

1. Handrails may be omitted on ramped aisles having a slope not steeper than 1 unit vertical in 5 units horizontal (20% slope) and having fixed seats on both sides of the aisle.
2. Handrails may be omitted where a guardrail is at the side of an aisle that conforms to the size and shape requirements for handrails.

Handrails located within the aisle width shall be discontinuous with gaps or breaks at intervals not to exceed five rows. These gaps or breaks shall have a clear width of not less than 22 inches (559 mm) not more than 36 inches (914 mm) measured horizontally.

1004.3.4.5 Elevators. Elevators opening into a corridor shall be provided with an elevator lobby at each floor containing such a corridor. The lobby shall completely separate the elevators from the corridor by construction conforming to Section 1004.3.4.3.1 and all openings into the lobby wall contiguous with the corridor shall be protected as required by Section 1004.3.4.3.2.

EXCEPTIONS:

1. In office buildings, separations need not be provided from a street floor lobby, provided the entire street floor is protected with an automatic sprinkler system.
2. Elevators not required to meet the shaft enclosure requirements of Section 711.
3. When additional doors are provided in accordance with Section 3007.
4. In fully sprinklered buildings, where elevator and stair shafts are pressurized in accordance with Section 905, elevator lobbies need not be provided.

Elevator lobbies shall comply with Section 3002.

[Statutory Authority: RCW 19.27.031, 19.27.074, 03-01-055, § 51-40-1004, filed 12/11/02, effective 7/1/03; 01-02-095, § 51-40-1004, filed 1/3/01, effective 7/1/01; 98-02-054, § 51-40-1004, filed 1/6/98, effective 7/1/98.]

WAC 51-40-1007 Means of egress requirements based on occupancy.

1007.5.9.1 Suites

General. A group of rooms in a Group I, Division 1.1, Division 1.2 or Division 2 Occupancy may be considered a suite when it complies with the following:

1. **Size.** Suites of rooms, other than suites containing patient sleeping rooms, shall not exceed 10,000 square feet (928.5 m²) in area. Suites containing patient sleeping rooms shall not exceed 5,000 square feet (465 m²) in area.

2. **Occupancy separation.** Each suite of rooms shall be separated from the remainder of the building by not less than one-hour fire-resistive occupancy separation.

3. **Visual supervision.** Each patient sleeping room in the suite shall be located to permit direct visual supervision by the facility staff.

4. **Other exits.** Exiting for portions of the building outside of a suite shall not require passage through the suite.

[Statutory Authority: RCW 19.27.031 and 19.27.074, 98-02-054, § 51-40-1007, filed 1/6/98, effective 7/1/98.]

WAC 51-40-1091 Table 10-A.

TABLE 10-A MINIMUM EGRESS REQUIREMENTS ¹

USE ²	MINIMUM OF TWO MEANS OF EGRESS ARE REQUIRED WHERE NUMBER OF OCCU- PANTS IS AT LEAST	OCCUPANT LOAD FACTOR ³ (square feet) x 0.0929 for m ²
1. Aircraft hangars (no repair)	10	500
2. Auction rooms	30	7
3. Assembly areas, concentrated use (without fixed seats) Auditoriums Churches and chapels Dance floors Lobby accessory to assembly occupancy Lodge rooms Reviewing stands Stadiums Waiting Area	50 50	7 3
4. Assembly areas, less-concentrated use Conference rooms Dining rooms Drinking establishments Exhibit rooms Gymnasiums Lounges Stages Gaming: keno, slot machine and live games area	50 50	15 11
5. Bowling alley (assume no occupant load for bowling lanes)	50	(see ft. note 4)
6. Children's homes and homes for the aged	6	80
7. Classrooms	50	20
8. Congregate residences (accommodating 10 or less persons and having an area of 3,000 square feet or less) Congregate residences (accommodating more than 10 persons or having an area of more than 3,000 square feet)	10 10	300 200
9. Courtrooms	50	40
10. Dormitories	10	50
11. Dwellings	10	300
12. Exercising rooms	50	50
13. Garage, parking	30	200
14. Health-care facilities— Sleeping rooms Treatment rooms	8 10	120 240
15. Hotels and apartments	10	200
16. Kitchen—commercial	30	200
17. Laboratories (Group B) Instructional and teaching laboratories at schools, colleges and universities All other Group B laboratories	10 10	50 100
18. Library— Reading rooms Stack areas	50 30	50 100
19. Locker rooms	30	50
20. Malls (see Chapter 4)	—	—
21. Manufacturing areas	30	200
22. Mechanical equipment room	30	300
23. Nurseries for children (day care)	7	35

USE ²	MINIMUM OF TWO MEANS OF EGRESS ARE REQUIRED WHERE NUMBER OF OCCUPANTS IS AT LEAST	OCCUPANT LOAD FACTOR ³ (square feet)
		x 0.0929 for m ²
24. Offices	30	100
25. School shops and vocational rooms	50	50
26. Skating rinks	50	50 on the skating area; 15 on the deck
27. Storage and stock rooms	30	300
28. Stores—retail sales rooms		
Basements and ground floor	50	30
Upper floors	50	60
29. Swimming pools	50	50 for the pool area; 15 on the deck
30. Warehouses ⁵	30	500
31. All others	50	100

¹ Access to, and egress from, buildings for persons with disabilities shall be provided as specified in Chapter 11.

² For additional provisions on number of exits form Groups H and I Occupancies and from rooms containing fuel-fired equipment or cellulose nitrate, see Sections 1007.4, 1007.5 and 1007.7, respectively.

³ This table shall not be used to determine working space requirements per person.

⁴ Occupant load based on five persons for each alley, including 15 feet (4572 mm) of runway.

⁵ Occupant load for warehouses containing approved high rack storage systems designed for mechanical handling may be based on the floor area exclusive of the rack area rather than the gross floor area.

[Statutory Authority: RCW 19.27.031 and 19.27.074. 98-02-054, § 51-40-1091, filed 1/6/98, effective 7/1/98.]

WAC 51-40-1100 Chapter 11—Accessibility.

[Statutory Authority: RCW 19.27.031 and 19.27.074. 98-02-054, § 51-40-1100, filed 1/6/98, effective 7/1/98.]

PART I - GENERAL

WAC 51-40-1101 Section 1101—Scope.

1101.1 General. Buildings or portions of buildings shall be accessible to persons with disabilities as required by this chapter.

Chapter 11 has been amended to comply with the Federal Fair Housing Act (FFHA) Guidelines as published by the U.S. Department of Housing and Urban Development (March 1991) and the Americans With Disabilities Act (ADA) Guidelines as published by the U.S. Architectural and Transportation Barriers Compliance Board and Department of Justice (July 1991).

Reference is made to Appendix Chapter 11 for FFHA and ADA requirements not regulated by this chapter. See Section 101.3.

1101.2 Design. The design and construction of accessible building elements shall be in accordance with this chapter. For a building, structure or building element to be considered to be accessible, it shall be designed and constructed to the minimum provisions of this chapter.

1101.3 Maintenance of Facilities. Any building, facility, dwelling unit, or site which is constructed or altered to be accessible or adaptable under this chapter shall be maintained accessible and/or adaptable during its occupancy.

1101.4 Alternate Methods. The application of Section 104.2.8 to this chapter shall be limited to the extent that alternate methods of construction, designs, or technologies shall provide substantially equivalent or greater accessibility.

1101.5 Modifications. Where full compliance with this chapter is impractical due to unique characteristics of the terrain, the building official may grant modifications in accordance with Section 104.2.7, provided that any portion of the building or structure that can be made accessible shall be made accessible to the greatest extent practical.

[Statutory Authority: RCW 19.27.031 and 19.27.074. 98-02-054, § 51-40-1101, filed 1/6/98, effective 7/1/98.]

WAC 51-40-1102 Section 1102—Definitions.

Section 1102. For the purpose of this chapter certain terms are defined as follows:

ACCESSIBLE is approachable and usable by persons with disabilities.

ACCESS AISLE is an accessible pedestrian space between elements, such as parking spaces, seating, and desks, that provides clearances appropriate for use of the elements.

ACCESSIBLE EXIT is an exit, as defined in Section 1101.2, which complies with this chapter and does not contain stairs, steps, or escalators.

ACCESSIBLE ROUTE OF TRAVEL is a continuous unobstructed path connecting all accessible elements and spaces in an accessible building or facility that can be negotiated by a person using a wheelchair and that is usable by persons with other disabilities.

ALTERATION (See Section 1110).

ALTERATION, SUBSTANTIAL (See Section 1110).

AREA FOR EVACUATION ASSISTANCE is an accessible space which is protected from fire and smoke and which facilitates egress.

AUTOMATIC DOOR is a door equipped with a power-operated mechanism and controls that open and close the door automatically upon receipt of a momentary actuating signal. The switch that begins the automatic cycle may be a photoelectric device, floor mat, or manual switch (see also, Power-assisted Door).

CLEAR is unobstructed.

CLEAR FLOOR SPACE is unobstructed floor or ground space (see Section 1106.2).

COMMON USE AREAS are rooms, spaces or elements inside or outside a building that are made available for use by occupants of and visitors to the building.

CROSS SLOPE is the slope that is perpendicular to the direction of travel.

CURB RAMP is a short ramp cutting through or built up to a curb.

DETECTABLE WARNING is a standardized surface feature built in or applied to walking surfaces or other elements to warn visually impaired persons of hazards on a circulation path.

DWELLING UNIT, TYPE A is an accessible dwelling unit that is designed and constructed in accordance with this chapter to provide greater accessibility than a Type B dwelling unit. (Type A dwelling units constructed in accordance with this Chapter also meet the design standards for Type B dwelling units.)

DWELLING UNIT, TYPE B is an accessible dwelling unit that is designed and constructed in accordance with this chapter. (Type B Dwelling Unit Standards are based on the U.S. Department of Housing and Urban Development (HUD) Federal Fair Housing Act Accessibility Guidelines.)

ELEMENT is an architectural or mechanical component of a building, facility, space, or site, such as telephones, curb ramps, doors, drinking fountains, seating, or water closets.

GROUND FLOOR is any occupiable floor less than one story above or below grade with direct access to grade. A building may have more than one ground floor.

LANDING is a level area (except as otherwise provided), within or at the terminus of a stair or ramp.

MARKED CROSSING is a crosswalk or other identified path intended for pedestrian use in crossing a vehicular way.

MULTISTORY DWELLING UNIT is a dwelling unit with finished living space located on one floor, and the floor or floors immediately above or below it.

PATH OF TRAVEL (See Section 1110).

PERSON WITH DISABILITY is an individual who has an impairment, including a mobility, sensory, or cognitive

(2003 Ed.)

impairment, which results in a functional limitation in access to and use of a building or facility.

POWER-ASSISTED DOOR is a door used for human passage, with a mechanism that helps to open the door, or relieve the opening resistance of a door, upon the activation of a switch or a continued force applied to the door itself.

PRIMARY ENTRANCE is a principal entrance through which most people enter the building. A building may have more than one primary entrance.

PRIMARY ENTRANCE LEVEL is the floor or level of the building on which the primary entrance is located.

PRIMARY FUNCTION is a major function for which the facility is intended.

PUBLIC USE AREAS are those interior or exterior rooms or spaces which are made available to the general public. Public use may be provided at a privately or publicly owned building or facility.

RAMP is any walking surface having a running slope exceeding 1 unit vertical in 48 units horizontal.

SERVICE ENTRANCE is an entrance intended primarily for delivery of goods or services.

SINGLE-STORY DWELLING UNIT is a dwelling unit with all finished living spaces located on one floor.

SITE is a parcel of land bounded by a property line or a designated portion of a public right-of-way.

TACTILE is an object that can be perceived using the sense of touch.

TECHNICALLY INFEASIBLE (See Section 1110).

TEXT TELEPHONE is machinery or equipment that employs interactive graphic (e.g., typed) communications through the transmission of coded signals across the standard telephone network. Text telephones include telecommunications display devices or telecommunications devices for the deaf (TDD's), or computers.

VEHICULAR WAY is a route intended for vehicular traffic, such as a roadway, driveway, or parking lot, located on a site.

[Statutory Authority: RCW 19.27.031 and 19.27.074. 98-02-054, § 51-40-1102, filed 1/6/98, effective 7/1/98.]

PART II - NEW CONSTRUCTION

WAC 51-40-1103 Section 1103—Building accessibility.

Section 1103.1 Where Required.

1103.1.1 General. Accessibility to temporary or permanent buildings or portions thereof shall be provided for all occupancy classifications except as modified by this chapter. See also Appendix Chapter 11.

[Title 51 WAC—p. 155]

EXCEPTIONS:

1. Floors or portions of floors not customarily occupied, including, but not limited to, elevator pits, observation galleries used primarily for security purposes, elevator penthouses, nonoccupiable spaces accessed only by ladders, catwalks, crawl spaces, narrow passageways, or freight elevators, piping and equipment catwalks and machinery, mechanical and electrical equipment rooms.
2. Temporary structures, sites and equipment directly associated with the construction process such as construction site trailers, scaffolding, bridging, or material hoists are not required to be accessible. This exception does not include walkways or pedestrian protection required by Chapter 30.

1103.1.2 Group A Occupancies.

1103.1.2.1 General. All Group A Occupancies shall be accessible as provided in this chapter.

EXCEPTION: In the assembly areas of dining and drinking establishments or religious facilities which are located in non-elevator buildings; where the area of mezzanine seating is not more than 25 percent of the total seating, an accessible means of vertical access to the mezzanine is not required, provided that the same services are provided in an accessible space which is not restricted to use only by persons with disabilities. Comparable facilities shall be available in all seating areas.

In banquet rooms or spaces where the head table or speaker's lectern is located on a permanent raised platform, the platform shall be accessible in compliance with Section 1106. Open edges on the raised platform shall be protected by a curb with a height of not less than 2 inches (51 mm).

Stadiums, theaters, auditoriums and similar occupancies shall provide wheelchair spaces in accordance with Table No. 11-A.

Wheelchair spaces shall be accessible and shall be located in places with unobstructed sight lines. Wheelchair spaces shall be reasonably distributed throughout the seating plan and located on an accessible route of travel. At least one companion fixed seat shall be provided next to each wheelchair space. Removable seats shall be permitted in the wheelchair spaces.

In addition, one percent, but not less than one, of all fixed seats shall be aisle seats with no armrests, or shall have removable or folding armrests on the aisle side. Each such seat shall be identified by a sign complying with Section 1106.16.1.1.

An accessible route of travel shall connect wheelchair seating locations with performance areas, including stages, arena floors, dressing rooms, locker rooms, and other spaces used by performers.

1103.1.2.2 Assistive listening devices. Assistive listening systems complying with Section 1106.21.2 shall be installed in assembly areas where audible communications are integral to the use of the space including stadiums, theaters, auditoriums, lecture halls, and similar areas; where fixed seats are provided, as follows:

1. Areas with an occupant load of 50 or more.
2. Areas where an audio-amplification system is installed.

Receivers for assistive listening systems shall be provided at a rate of 4 percent of the total number of seats, but in no case fewer than two receivers. In other assembly areas, where permanently installed assistive listening systems are not provided, electrical outlets shall be provided at a rate of not less than 4 percent of the total occupant load.

Signage complying with Section 1106.16.1.3 shall be installed to notify patrons of the availability of the listening system.

1103.1.3 Group B, F, M and S Occupancies. All Group B, F, M and S Occupancies shall be accessible as provided in this chapter. Assembly spaces in Group B, F, M and S Occupancies shall comply with Section 1103.1.2.2.

1103.1.4 Group E Occupancies. All Group E Occupancies shall be accessible as provided in this chapter. Assembly spaces in Group E Occupancies shall comply with Section 1103.1.2.2.

1103.1.5 Group H Occupancies. All Group H Occupancies shall be accessible as provided in this chapter.

1103.1.6 Group I Occupancies. All Group I Occupancies shall be accessible in all public use, common use, and employee use areas, and shall have accessible patient rooms, cells, and treatment or examination rooms as follows:

1. In Group I, Division 1.1 patient care units within hospitals which specialize in treating conditions that affect mobility, all patient rooms in each nursing unit including associated toilet rooms and bathrooms.

2. In Group I, Division 1.1 patient care units within hospitals which do not specialize in treating conditions that affect mobility, at least 1 in every 10 patient rooms in each nursing unit, including associated toilet rooms and bathrooms.

3. In Group I, Division 1.1 and Division 2 nursing homes and long-term care facilities, at least 1 in every 2 patient rooms, including associated toilet rooms and bathrooms.

4. In Group I, Division 3 Mental Health Occupancies, at least 1 in every 10 patient rooms, including associated toilet rooms and bathrooms.

5. In Group I, Division 3 Jail, Prison and Similar Occupancies, at least 1 in every 100 rooms or cells, including associated toilet rooms and bathrooms.

6. In Group I Occupancies, all treatment and examination rooms shall be accessible.

In Group I Division 1.1 and 2 Occupancies, at least one accessible entrance that complies with Section 1103.2 shall be under shelter. Every such entrance shall include a passenger loading zone which complies with Section 1108.2.

1103.1.7 Group U Occupancies. Group U, Division 1 Occupancies shall be accessible as follows:

1. Private garages and carports which contain accessible parking serving Type A dwelling units, accessible hotel and lodging rooms and congregate residences.

2. In Group U, Division 1 agricultural buildings, access need only be provided to paved work areas and areas open to the general public.

1103.1.8 Group R Occupancies.

1103.1.8.1 General. All Group R Occupancies shall be accessible as provided in this chapter. Public- and common-use areas and facilities such as recreational facilities, laundry facilities, garbage and recycling collection areas, mailbox locations, lobbies, foyers, and management offices shall be accessible.

EXCEPTIONS: Common- or public-use facilities accessory to buildings not required to contain either Type A or Type B dwelling units in accordance with Section 1103.1.8.2.

1103.1.8.2 Number of dwelling units. In all Group R, Division 1 apartment buildings the total number of Type A dwelling units shall be as required by Table No. 11-B. All other dwelling units shall be designed and constructed to the requirements for Type B units as defined in this chapter.

EXCEPTIONS:

1. Group R Occupancies containing no more than three dwelling units need not be accessible.
2. Dwelling units in Group R, Division 1 apartment buildings which are located on floors other than the ground floor where no elevator is provided within the building need not comply with standards for Type B dwelling units; provided:
 - 2.1. Where the ground floor is not a Group R Occupancy, the first level of Group R Occupancy, including dwelling units, shall be accessible; and
 - 2.2. The number of Type A dwelling units provided shall not be reduced below the number required by Table No. 11-B. See also Section 1105.3.1.
3. Dwelling units with two or more stories in a non-elevator building need not comply with standards for Type B dwelling units.
4. For sites where multiple, non-elevator buildings are planned for a single site and where portions of the site have grades prior to development which exceed 10 percent, the building official may approve the following modifications:
 - 4.1. Number of Dwelling Units:
 - 4.1.1. The number of Type B dwelling units provided may be reduced to a percentage of the ground floor units which is equal to the percentage of the entire site having grades prior to development which are 10 percent or less; but in no case shall the number of Type B dwelling units be less than 20 percent of the ground floor dwelling units on the entire site; and
 - 4.1.2. The number of Type A dwelling units provided shall not be reduced below the number required by Table No. 11-B; and
 - 4.2. Both Type A and B dwelling units may be located in the building or buildings located on the portion of the site where the grade prior to development has slopes of 10 percent or less; and
 - 4.3. Common-use facilities accessory to buildings not required to contain either Type A or B dwelling units in accordance with Item 4.1.1, above, need not be accessible unless there are no other similar facilities provided on the site.

See also Appendix Chapter 11, Division I.

1103.1.8.3 Hotels and lodging houses. In all hotels and lodging houses, accessible guest rooms, including associated bathing, shower, and toilet facilities, shall be provided in accordance with Table 11-C. In addition, sleeping rooms or suites for persons with hearing impairments shall be provided in accordance with Table 11-D. In addition, public- and common-use areas of all hotels and lodging houses shall be accessible.

EXCEPTION: Group R, Division 3 lodging houses that are occupied by the owner or proprietor of the lodging house.

Required sleeping rooms for persons with hearing impairments shall have visible alarms complying with Section 1106.15. Such rooms shall have installed telephones complying with Section 1106.14.3, and an electrical outlet installed within 48 inches (1220 mm) of the telephone connection. Such rooms shall have devices separate from the visible alarm system which provide visible notification of incoming telephone calls and door bell actuation.

Where provided in accessible guest rooms the following facilities shall be accessible: dining areas; kitchens; kitchenettes; wet bars; patios; balconies; terraces; or similar facilities.

1103.1.8.4 Proportional distribution. Accessible dwelling units shall be apportioned among efficiency dwelling units, single bedroom units and multiple bedroom units, in proportion to the numbers of such units in the building. Accessible hotel guest rooms shall be apportioned among the various classes of sleeping accommodations.

1103.1.8.5 Congregate residences. In congregate residences with multi-bed rooms or spaces, a percentage equal to the minimum number of accessible rooms required by Table No. 11-C shall be accessible in accordance with Section 1106.26.

EXCEPTION: Congregate residences with 10 or fewer occupants need not be accessible.

1103.1.9 Other parking facilities. Principal use parking facilities which are not accessory to the use of any building or structure shall provide accessible spaces in accordance with Table No. 11-F.

1103.2 Design and Construction.

1103.2.1 General. When accessibility is required by this chapter, it shall be designed and constructed in accordance with this chapter.

1103.2.2 Accessible route of travel. When a building, or portion of a building, is required to be accessible, an accessible route of travel shall be provided to all portions of the building, to accessible building entrances, and connecting the building and the public way. The accessible route of travel to areas of primary function may serve but shall not pass through kitchens, storage rooms, toilet rooms, bathrooms, closets, or other similar spaces.

EXCEPTIONS:

1. A single accessible route shall be permitted to pass through a kitchen or storage room in an accessible dwelling unit.
2. An accessible route of travel need not be provided between floor levels, provided that:

All floor levels in the building contain less than 3,000 square feet (278.7 m²) each; or

Where only two floor levels are provided, either floor is less than 3,000 square feet (278.7 m²).

This exception shall not apply to:

 - 2.1. The offices of health care providers; or
 - 2.2. Transportation facilities and airports; or
 - 2.3. Buildings owned or leased by government agencies; or
 - 2.4. Multi-tenant Group M Retail and Wholesale Occupancies of five tenant spaces or more.
3. For sites where natural terrain or other unusual property characteristics do not allow the provisions of an accessible route of travel from the public way to the

building, the point of vehicular debarkation may be substituted for the accessible entrance to the site.

4. In a one story building without a basement, an accessible route of travel need not be provided to mezzanine floors containing less than 3,000 square feet. (For Group R, Division 1 Occupancies, see Section 1105.3.1.)

Accessible routes of travel serving any accessible space or element shall also serve as a means of egress for emergencies or connect to an area of evacuation assistance.

Where more than one building or facility is located on a site, accessible routes of travel shall connect accessible buildings and accessible site facilities. The accessible route of travel shall be the most practical direct route connecting accessible building entrances, accessible site facilities and the accessible site entrances.

1103.2.3 Primary entrance access. At least 50% of all public entrances, or a number equal to the number of exits required by Section 1004.2.3, whichever is greater, shall be accessible. One of the accessible public entrances shall be the primary entrance to a building. At least one accessible entrance must be a ground floor entrance. Public entrances do not include loading or service entrances.

EXCEPTION: In Group R, Division 1 apartment buildings only the primary entrance need be accessible, provided that the primary entrance provides an accessible route of travel to all dwelling units required to be accessible.

Where a building is designed not to have common or primary entrances, the primary entrance to each individual dwelling unit required to be accessible, and each individual tenant space, shall be accessible.

1103.2.4 Signs.

1103.2.4.1 International Symbol of Access. The following elements and spaces of accessible facilities shall be identified by the International Symbol of Access:

1. Accessible parking spaces.
2. Accessible entrance when not all entrances are accessible (inaccessible entrances shall have directional signage to indicate the route to the nearest accessible entrance).

EXCEPTION: Individual entrances into dwelling units.

3. Accessible passenger loading zone(s).
4. Accessible toilet and bathing facilities when not all are accessible.

EXCEPTION: Toilet and bathing facilities within dwelling units, patient rooms and guest rooms.

At every major junction along or leading to an exterior accessible route of travel, there shall be a sign displaying the International Symbol of Access. Signage shall indicate the direction to accessible entrance and facilities.

See also Sections 1103.1.2.1, 1104.2.5 and 1106.24.3.

1103.2.4.2 Other signs. Where provided, signs which identify permanent rooms and spaces shall comply with Sections 1106.16.2, 1106.16.3 and 1106.16.5. Where provided, other signs which provide direction to or information about the building or portion of a building shall comply with Sections 1106.16.3 and 1106.16.4.

[Title 51 WAC—p. 158]

EXCEPTION: Building directories and all temporary signs.

In hotels and lodging houses, a list of accessible guest rooms shall be posted permanently in a location not visible to the general public, for staff use at each reception or check-in desk.

In assembly areas, a sign notifying the general public of the availability of accessible seating and assistive listening systems shall be provided at ticket offices or similar locations.

[Statutory Authority: RCW 19.27.031 and 19.27.074. 98-02-054, § 51-40-1103, filed 1/6/98, effective 7/1/98.]

WAC 51-40-1104 Section 1104—Egress and areas of evacuation assistance.

Section 1104.1 General. In buildings or portions of buildings required to be accessible, accessible means of egress shall be provided in the same number as required for exits by Chapter 10. When an exit required by Chapter 10 is not accessible, an area for evacuation assistance shall be provided.

EXCEPTIONS:

1. Areas of evacuation assistance are not required in buildings where an approved, automatic fire-extinguishing system is installed in accordance with UBC Standard 9-1, provided that quick-response sprinkler heads are used where allowed by the standard; and that a written fire- and life-safety emergency plan, which specifically addresses the evacuation of persons with disabilities, is approved by the building official and the fire chief.
2. Areas for evacuation assistance are not required in open parking garages.

Every area for evacuation assistance shall comply with the requirements of this code and shall adjoin an accessible route of travel which shall comply with Section 1106.

1104.2 Areas for Evacuation Assistance.

1104.2.1 Location and construction. An area for evacuation assistance shall be one of the following:

1. A portion of a landing within a smokeproof enclosure, complying with Section 1005.3.3.

2. A portion of an exterior exit balcony, located immediately adjacent to an exit stairway, when the exterior exit balcony complies with Section 1006.3.2. Openings to the interior of the building located within 20 feet (6096 mm) of the area for evacuation assistance shall be protected with fire assemblies having a three-fourths-hour fire-protection rating.

3. A portion of a one-hour fire-resistive corridor complying with Sections 1004.3.4.3, 1004.3.4.3.1 and 1004.3.4.3.2 located immediately adjacent to an exit enclosure.

4. A vestibule located immediately adjacent to an exit enclosure and constructed to the same fire-resistive standards as required by Section 1004.3.4.3, 1004.3.4.3.1 and 1004.3.4.3.2.

5. A portion of a stairway landing within an exit enclosure which is vented to the exterior and is separated from the interior of the building by not less than one-hour fire-resistive door assemblies.

6. When approved by the building official, an area or room which is separated from other portions of the building by a smoke barrier. Smoke barriers shall have a fire-resistive rating of not less than one hour and shall completely enclose the area or room. Doors in the smoke barrier shall be tight-fitting smoke-and draft-control assemblies having a fire-protection rating of not less than 20 minutes and shall be self-closing or automatic closing. The area or room shall be provided with an exit directly to an exit enclosure. When the room or area exits into an exit enclosure which is required to be of more than one-hour fire-resistive construction, the room or area shall have the same fire-resistive construction, including the same opening protection, as required for the adjacent exit enclosure.

7. An elevator lobby complying with Section 1104.4.

1104.2.2 Size. Each area for evacuation assistance shall provide at least two wheelchair spaces not smaller than 30 inches by 48 inches (760 mm by 1220 mm) for each space. The area for evacuation assistance shall not encroach on any required exit width. The total number of such wheelchair spaces per story shall not be less than 1 for every 200 persons of calculated occupant load served by the area for evacuation assistance.

EXCEPTION: The building official may reduce the minimum number of 30-inch (760 mm) by 48-inch (1220 mm) areas to one for each area for evacuation assistance on floors where the occupant load is less than 200.

1104.2.3 Stairway width. Each stairway adjacent to an area for evacuation assistance shall have a minimum clear width of 48 inches (1220 mm) between handrails.

1104.2.4 Two-way communication. A telephone with controlled access to a public telephone system or another method of two-way communication shall be provided between each area for evacuation assistance and the primary entrance. The telephone or other two-way communication system shall be located with the reach ranges specified in Section 1106.2.4. The fire department may approve location other than the primary entrance. The communication system shall not require voice communication.

1104.2.5 Identification. Each area for evacuation assistance shall be identified by a sign which states: **AREA FOR EVACUATION ASSISTANCE** and the International Symbol of Access. The sign shall be illuminated when exit sign illumination is required. The sign shall comply with Sections 1003.2.8.4 and 1003.2.8.5. In each area for evacuation assistance, instructions on the use of the area under emergency conditions shall be posted adjoining the two-way communication system.

1104.3 Accessible Exits. All exterior exits which are located adjacent to accessible areas and within 6 inches (152 mm) of grade shall be accessible.

1104.4 Area for Evacuation Assistance, High-Rise Alternative. Within a building of any height or occupancy, constructed in accordance with the requirements of Section 403, an area for evacuation assistance may be located in the elevator lobby, or adjacent to the elevator where no lobby is required, when:

1. The area for evacuation assistance complies with the requirements for size, two-way communication and identification as specified in Section 1104.2; and,

2. Elevator shafts are pressurized as required for smokeproof enclosures in Section 1005.3.3. Such pressurization system shall be activated by smoke detectors on each floor located in a manner approved by the building official. Pressurization equipment and its ductwork within the building shall be separated from other portions of the building by a minimum of two-hour fire-resistive construction.

3. The manager of the building has established and maintains a written fire- and life-safety emergency plan which, in addition to other provisions, shall specifically address the evacuation of persons with disabilities. Such plan shall be approved by the building official and the fire chief.

[Statutory Authority: RCW 19.27.031, 19.27.074, 01-02-095, § 51-40-1104, filed 1/3/01, effective 7/1/01; 98-02-054, § 51-40-1104, filed 1/6/98, effective 7/1/98.]

WAC 51-40-1105 Section 1105—Facility accessibility.

Section 1105.1 General. Where buildings are required to be accessible, building facilities shall be accessible to persons with disabilities as provided in this section. For Group R, Division 1 apartment buildings, where specific floors of a building are required to be accessible, the requirements shall apply only to the facilities located on accessible floors.

All building facilities or elements required by this section to be accessible shall be designed and constructed in accordance with Section 1106.

1105.2 Bathing and Toilet Facilities.

1105.2.1 Bathing facilities. When bathing facilities are provided, at least 2 percent, but not less than 1, bathtub or shower shall be accessible. In dwelling units where a separate bathtub and shower are provided in the same room, at least one shall be accessible.

1105.2.2 Toilet facilities. Toilet facilities located within accessible dwelling units, guest rooms, and congregate residences shall comply with Sections 1106.11 and 1106.27.

EXCEPTION: Within accessible dwelling units, only one toilet facility need be accessible.

In each toilet facility in other occupancies, at least one wheelchair accessible toilet stall with an accessible water closet shall be provided. In addition, when there are 6 or more water closets within a toilet facility, at least one ambulatory accessible toilet stall complying with Section 1106.11.4 shall also be installed.

Where urinals are provided, at least one urinal shall be accessible.

1105.2.3 Lavatories, mirrors and towel fixtures. At least one accessible lavatory shall be provided within any toilet facility. Where mirrors, towel fixtures and other toilet and bathroom accessories are provided, at least one of each shall be accessible.

1105.2.4 Adaptable fixtures in dwelling units. See Section 1106.27.2 for adaptable fixtures in dwelling units.

1105.3 Elevators, Platform Lifts and Stairways.

1105.3.1 Elevators.

1105.3.1.1 Where required. In multi-story buildings or portions thereof required to be accessible by Section 1103, at least one elevator shall serve each level, including mezzanines. Other than within an individual dwelling unit, where an elevator is provided but not required, it shall be accessible.

EXCEPTIONS:

1. In Group R, Division 1 Apartment Occupancies, an elevator is not required where accessible dwelling units and guest rooms are accessible by ramp or by grade level route of travel.
2. In a building of fewer than three stories, an elevator is not required where ramps, grade-level entrances or accessible horizontal exits from an adjacent building, are provided to each floor.
3. In multi-story parking garages, an elevator is not required where an accessible route of travel is provided from accessible parking spaces on levels with accessible horizontal connections to the primary building served.
4. In Group R, Division 1 hotels and lodging houses, less than 3 stories in height, an elevator is not required, provided that all accessible guest rooms are located on the ground floor.

1105.3.1.2 Design. All elevators shall be accessible.

EXCEPTIONS:

1. Private elevators serving only one dwelling unit.
2. Where more than one elevator is provided in the building, elevators used exclusively for movement of freight.

Elevators required to be accessible shall be designed and constructed to comply with Chapter 296-81 of the Washington Administrative Code.

1105.3.2 Platform lifts. Platform lifts may be used in lieu of an elevator under one of the following conditions subject to approval by the building official:

1. To provide an accessible route of travel to a performing area in a Group A Occupancy; or,
2. To provide unobstructed sight lines and distribution for wheelchair viewing positions in Group A Occupancies; or
3. To provide access to spaces with an occupant load of less than 5 that are not open to the public; or,
4. To provide access where existing site or other constraints make use of a ramp or elevator infeasible.

All platform lifts used in lieu of an elevator shall be capable of independent operation and shall comply with Chapter 296-81 of the Washington Administrative Code.

1105.3.3 Stairways. Stairways shall comply with Section 1106.9.

1105.4 Other Building Facilities.

1105.4.1 Water fountains. On any floor where water fountains are provided, at least 50 percent, but in no case less than one fountain, shall be accessible complying with Section 1106.13 and at least one fountain shall be mounted at a standard height.

1105.4.2 Telephones. On any floor where public telephones are provided at least one telephone shall be accessible. On any floor where 2 or more banks of multiple telephones are provided, at least one telephone in each bank shall be accessible and at least one telephone per floor shall be designed to allow forward reach complying with Section 1106.2.4.5.

Where any bank of public telephones consists of 3 or more telephones, at least one telephone in each bank shall be equipped with a shelf and electrical outlet complying with Section 1106.14.7.

All accessible telephones and at least 25 percent of all other public telephones, but in no case less than one, shall be provided with volume controls in accordance with Section 1106.14.3 and shall be dispersed among the public telephones provided in the building.

Where four or more public telephones are provided at a building site, and at least one is in an interior location, at least one interior telephone shall be a text telephone in accordance with Section 1106.14.

Where interior public pay phones are provided in transportation facilities; assembly and similar areas including stadiums and arenas; convention centers; hotels with convention facilities; or covered malls; or in or adjacent to hospital emergency, recovery, or waiting rooms; at least one interior text telephone shall be provided.

1105.4.3 Kitchens. Kitchens within accessible dwelling units shall be designed in accordance with Sections 1106.12 and 1106.27.

EXCEPTION: Kitchens in Type B dwelling units need not comply with Section 1106.12.1 (See Section 1106.27.1).

Kitchens, kitchenettes, or wet bars in other than dwelling units, which are provided accessory to a sleeping room, guest room, or suite, shall be designed in accordance with Section 1106. Countertops and sinks shall be no more than 34 inches (865 mm) above the finished floor. At least 50 percent of shelf space in cabinets and appliances shall be within the reach ranges of Section 1106.2.4.

1105.4.4 Recreation facilities. Where common- or public-use recreational facilities, swimming pools, hot tubs, spas, and similar facilities are provided, they shall be accessible. Swimming pools shall be accessible by transfer tier, hydraulic chair, ramp, or other means. Hot tubs and spas need be accessible only to the edge of the facility.

EXCEPTION: For Group R, Division 1 Apartment Occupancies, common- or public-use facilities accessory to buildings not required to contain either Type A or Type B dwelling units in accordance with Section 1103.1.8.2.

1105.4.5 Fixed or built-in seating or tables. Where fixed or built-in seating or tables are provided, at least 5 percent, but no fewer than one, shall be accessible. Accessible fixed or built-in seating or tables shall comply with Section 1106.19. In eating and drinking establishments, such seating or tables shall be distributed throughout the facility.

1105.4.6 Storage facilities. In other than Group R, Division 1 apartment buildings, where fixed or built-in storage facilities such as cabinets, shelves, closets, and drawers are pro-

vided in accessible spaces, at least one of each type provided shall contain storage space complying with Section 1106.18.

1105.4.7 Customer service facilities.

1105.4.7.1 Dressing and fitting rooms. Where dressing or fitting rooms are provided for use by the general public, patients, customers or employees, 5 percent, but not less than one, in each group of rooms serving distinct and different functions shall be accessible in accordance with Section 1106.24.

1105.4.7.2 Counters and windows. Where customer sales and service counters or windows are provided, a portion of the counter, or at least one window, shall be accessible in accordance with Section 1106.24.2.

1105.4.7.3 Shelving and display. Self-service shelves or display units in retail occupancies shall be located on an accessible route of travel in accordance with Section 1103.2.2. Not all self-service shelves and display units need be located within reach ranges required by Section 1106.2.4.

1105.4.7.4 Check-out aisles. Accessible check-out aisles shall be installed in accordance with Table No. 11-E and Section 1106.24.3.

1105.4.7.5 Food service lines. Where self-service shelves are provided in dining and drinking establishments, at least 50 percent of each type shall comply with Sections 1106.2 and 1106.22.

1105.4.8 Controls, operating mechanisms, and hardware. Controls, operating mechanisms, and hardware, including; switches that control lighting, ventilation or electrical outlets; in accessible spaces, along accessible routes or as parts of accessible elements, shall comply with Section 1106.3.

1105.4.9 Alarms. Where provided, alarm systems shall include both audible and visible alarms. Visible alarm devices shall be located in all assembly areas; common-use areas, including toilet rooms and bathing facilities; hallways and lobbies; and hotel guest rooms as required by Section 1103.1.8.3.

EXCEPTIONS:

1. Alarm systems in Group I, Division 1.1 and 2 Occupancies may be modified to suit standard health care design practice.
2. Visible alarms are not required in Group R, Division 1 apartment buildings.
3. Visible alarms are not required in employee assigned work areas, whether they are single or multiple work stations.

[Statutory Authority: RCW 19.27.031, 19.27.074, 01-02-095, § 51-40-1105, filed 1/3/01, effective 7/1/01; 98-02-054, § 51-40-1105, filed 1/6/98, effective 7/1/98.]

WAC 51-40-1106 Section 1106—Accessible design and standards.

Section 1106.1 General. Where accessibility is required by this chapter, buildings and facilities shall be designed and constructed in accordance with this section, unless otherwise specified in this chapter.

(2003 Ed.)

1106.2 Space Allowance and Reach Ranges.

1106.2.1 Wheelchair passage width. The minimum clear width for single wheelchair passage shall be 36 inches (915 mm). The minimum width for two wheelchairs to pass is 60 inches (1525 mm).

EXCEPTION: The minimum width for single wheelchair passage may be 32 inches (815 mm) for a maximum distance of 24 inches (610 mm).

1106.2.2 Wheelchair turning spaces. Wheelchair turning spaces shall be designed and constructed to satisfy one of the following requirements:

1. A turning space not less than 60 inches (1525 mm) in diameter; or,

2. A turning space at T-shaped intersections or within a room, where the minimum width is not less than 36 inches (915 mm). Each segment of the T shall be clear of obstructions not less than 24 inches (610 mm) in each direction.

Wheelchair turning space may include knee and toe clearance in accordance with Section 1106.2.4.3.

1106.2.3 Unobstructed floor space. A floor space, including the vertical space above such floor space, which is free of any physical obstruction including door swings, to a height of 29 inches (737 mm). Where a pair of doors occurs, the swing of the inactive leaf may be considered to be unobstructed floor space. Unobstructed floor space may include toe spaces that are a minimum of 9 inches (230 mm) in height and not more than 6 inches (152 mm) in depth.

1106.2.4 Clear floor or ground spaces and maneuvering clearance space for wheelchairs.

1106.2.4.1 Size. The minimum clear floor or ground space required to accommodate a single, stationary wheelchair occupant shall be not less than 30 inches (760 mm) by 48 inches (1220 mm).

1106.2.4.2 Approach. Wheelchair spaces shall be designed to allow for forward or parallel approach to an accessible feature.

1106.2.4.3 Knee and toe clearances. Spaces under obstructions, work surfaces or fixtures may be included in the clear floor or ground space provided that they are at least 30 inches (760 mm) in width, a minimum of 27 inches (685 mm) in height, and not greater than 25 inches (635 mm) in depth. Toe spaces under obstructions, work surfaces or fixtures which comply with the requirements for unobstructed floor space may be included in the clear floor or ground space.

1106.2.4.4 Approach to wheelchair spaces. One full unobstructed side of the clear floor or ground space for a wheelchair shall adjoin or overlap an accessible route of travel, or shall adjoin another wheelchair clear space. Clear space located in an alcove or otherwise confined on all or part of three sides shall be not less than 36 inches (915 mm) in width where forward approach is provided, or 60 inches (1525 mm) in width where parallel approach is provided.

1106.2.4.5 Forward reach. Where the clear floor space allows only forward approach to an object, the maximum forward reach allowed shall not be higher than 48 inches (1220 mm). Reach obstructions 20 inches (510 mm) or less in depth may project into the clear space provided that knee clearance is maintained in accordance with Section 1106.2.4.3. Reach obstructions greater than 20 inches (510 mm) in depth may project into the clear space provided that the reach obstruction shall not exceed 25 inches (635 mm) in depth and the maximum forward reach shall not exceed 44 inches (1118 mm) in height. The minimum low forward reach shall not be lower than 15 inches (380 mm).

1106.2.4.6 Side reach. Where the clear floor space allows parallel approach by a person in a wheelchair, the maximum high side reach allowed shall not be higher than 48 inches (1219 mm). Obstructions no greater than 34 inches (865 mm) in height and no more than 24 inches (610 mm) in depth may be located in the side reach area provided that when such obstructions are present, the side reach shall not exceed 46 inches (1170 mm) in height. The minimum low side reach shall not be lower than 9 inches (230 mm).

1106.3 Controls and Hardware.

1106.3.1 Operation. Handles, pulls, latches, locks, and other operating devices on doors, windows, cabinets, plumbing fixtures, and storage facilities, shall have a lever or other shape which will permit operation by wrist or arm pressure and which does not require tight grasping, pinching or twisting to operate. Doors shall comply with Section 1003.3.1.5.

The force to activate controls on lavatories and water fountains and flush valves on water closets and urinals shall not be greater than 5 pounds (22.2 N).

1106.3.2 Mounting heights. The highest operable part of environmental and other controls, dispensers, receptacles, and other operable equipment shall be within at least one of the reach ranges specified in Section 1106.2.4, and not less than 36 inches (915 mm) above the floor. Electrical and communications system receptacles on walls shall be mounted a minimum of 15 inches (380 mm) above the floor. Door hardware shall be mounted at not less than 36 inches (915 mm) and not more than 48 inches (1220 mm) above the floor.

1106.3.3 Clear floor space. Clear floor space that allows a forward or a side approach shall be provided at all controls or hardware.

1106.4 Accessible Route of Travel.

1106.4.1 Width. The minimum clear width of an accessible route of travel shall be 36 inches (915 mm) except at doors (see Section 1106.10.2). Where an accessible route includes a 180 degree turn around an obstruction which is less than 48 inches (1220 mm) in width, the clear width of the accessible route of travel around the obstruction shall be 42 inches (1065 mm) minimum. For exterior accessible routes of travel, the minimum clear width shall be 44 inches (1118 mm).

EXCEPTION: The minimum width for single wheelchair passage may be 32 inches (815 mm) for a maximum distance of 24 inches (610 mm).

Where an accessible route of travel is less than 60 inches (1525 mm) in width, passing spaces at least 60 inches (1525 mm) by 60 inches (1525 mm) shall be located at intervals not to exceed 200 feet (61 m). A T-shaped intersection of two corridors or walks may be used as a passing space.

1106.4.2 Height. Accessible routes shall have a clear height of not less than 79 inches (2007 mm). Where the vertical clearance of an area adjoining an accessible route of travel is less than 79 inches (2007 mm) but more than 27 inches (685 mm), a continuous permanent barrier shall be installed to prevent traffic into such areas of reduced clearance.

1106.4.3 Slope. An accessible route of travel shall have a running slope not greater than 1 vertical in 12 horizontal. An accessible route of travel with a running slope greater than 1 vertical in 20 horizontal shall comply with Section 1106.8. Cross slopes of an accessible route of travel shall not exceed 1 vertical in 48 horizontal.

1106.4.4 Changes in level. Changes in level along an accessible route of travel shall comply with Section 1106.6. Stairs or escalators shall not be part of an accessible route of travel. Any raised area within an accessible route of travel shall be cut through to maintain a level route or shall have curb ramps at both sides and a level area not less than 48 inches (1220 mm) long connecting the ramps.

1106.4.5 Surfaces.

1106.4.5.1 General. All floor and ground surfaces in an accessible route of travel shall comply with Section 1106.7.

1106.4.5.2 Detectable warnings. Curb ramps shall have detectable warnings complying with Section 1106.17. Detectable warnings shall extend the full width and depth of the curb ramp.

1106.4.6 Illumination. Illumination shall be provided along an exterior accessible route of travel at any time the building is occupied, with an intensity of not less than one footcandle (10.76 lx) on the surface of the route.

1106.4.7 Curb ramps.

1106.4.7.1 Slope. Slopes of curb ramps shall comply with Section 1106.8. Transitions from ramps to walks, gutters, or vehicular ways shall be flush and free of abrupt changes in height. Maximum slopes of adjoining gutters and road surfaces immediately adjacent to the curb ramp or accessible route of travel shall not exceed 1 vertical in 20 horizontal.

1106.4.7.2 Width. Curb ramps shall be not less than 36 inches (915 mm) in width, exclusive of the required side slopes.

1106.4.7.3 Side slopes of curb ramps. Curb ramps located where pedestrians must walk across the ramp, or where not protected by handrails or guardrails, shall have sloped sides. The maximum side slope shall be 1 vertical in 10 horizontal. Curb ramps with returned curbs may be used where pedestrians would not normally walk across the ramp.

EXCEPTION: Where the width of the walking surface at the top of the ramp and parallel to the run of the ramp is less than

48 inches (1220 mm), the maximum side slope shall be 1 vertical in 12 horizontal.

1106.4.7.4 Location. Built-up curb ramps shall be located so as not to project into vehicular ways nor be located within accessible parking spaces.

1106.4.7.5 Obstructions. Curb ramps shall be located or protected to prevent their obstruction by parked vehicles.

1106.4.7.6 Location at marked cross walks. Curb ramps at marked cross walks shall be wholly contained within the markings, excluding any sloped sides.

1106.4.7.7 Orientation. Curb ramps shall be oriented in the same direction as pedestrian flow of crosswalks; diagonally oriented curb ramps are prohibited.

1106.4.8 Vehicular areas. Where an accessible route of travel crosses or adjoins a vehicular way, and where there are no curbs, railings or other elements which separate the pedestrian and vehicular areas, and which are detectable by a person who has a severe vision impairment, the boundary between the areas shall be defined by a continuous detectable warning not less than 36 inches (915 mm) wide, complying with Section 1106.17.

1106.5 Protruding Objects. Protruding objects shall not reduce the clear width of a route of travel or maneuvering space. Any wall- or post-mounted object with its leading edge between 27 inches (685 mm) and 79 inches (2007 mm) above the floor may project not more than 4 inches (102 mm) into a route of travel, corridor, passageway, or aisle. Any wall- or post-mounted projection greater than 4 inches (102 mm) shall extend to the floor.

1106.6 Changes in Level. Accessible routes of travel and accessible spaces within buildings shall have continuous common floor or ramp surfaces. Abrupt change in height greater than 1/4 inch (6 mm) shall be beveled to 1 vertical in 2 horizontal. Changes in level greater than 1/2 inch (13 mm) shall be accomplished by means of a ramp meeting the requirements of Section 1106.8, a curb ramp meeting the requirements of Section 1106.4.7, or an elevator or platform lift meeting the requirements of Section 1105.3. For Type B dwelling units, see also Section 1106.27.

1106.7 Floor Coverings and Surface Treatments.

1106.7.1 General. All surfaces shall be firm and stable.

1106.7.2 Carpeting. Carpeting and floor mats in accessible areas shall be securely fastened to the underlying surface, and shall provide a firm, stable, continuous, and relatively smooth surface.

1106.7.3 Slip-resistant surfaces. Showers; locker rooms; swimming pool, spa, and hot tub decks; toilet rooms; and other areas subject to wet conditions shall have slip-resistant floors.

Exterior accessible routes of travel shall have slip-resistant surfaces.

1106.7.4 Grates. Within an accessible route of travel, grates shall have openings not more than 1/2 inch (13 mm) in one

direction. Where grates have elongated openings, they shall be placed so that the long dimension is perpendicular to the dominant direction of travel. The maximum vertical surface change shall be 1/8 inch (3 mm).

1106.7.5 Expansion and construction joints. Expansion and construction joints in exterior routes of travel shall have a width of not more than 1/2 inch (13 mm), shall be filled with a firm, compressible, elastic material, and shall be substantially level with the surface of the accessible route of travel.

1106.8 Ramps.

1106.8.1 General. Ramps required to be accessible shall comply with Section 1003.3.4 and the provisions of this section. No ramp shall change direction between landings, except ramps with an inside radius of 30 feet (9144 mm) or greater.

1106.8.2 Slope and rise. The maximum slope of a ramp shall be 1 vertical in 12 horizontal. The maximum rise for any run shall be 30 inches (760 mm).

1106.8.3 Width. The minimum width of a ramp shall be not less than 36 inches (915 mm) for interior ramps and 44 inches (1118 mm) for exterior ramps.

1106.8.4 Landings. Ramps within the accessible route of travel shall have landings at the top and bottom, and at least one intermediate landing shall be provided for each 30 inches (760 mm) of rise. Landings shall be level and have a minimum dimension measured in the direction of ramp run of not less than 60 inches (1525 mm). Where the ramp changes direction at a landing, the landing shall be not less than 60 inches (1525 mm) by 60 inches (1525 mm). The width of any landing shall be not less than the width of the ramp.

1106.8.5 Handrails. Ramps having slopes steeper than 1 vertical to 20 horizontal shall have handrails as required for stairways, except that intermediate handrails as required in Section 1003.3.3.6 are not required. Handrails shall be continuous provided that they shall not be required at any point of access along the ramp, nor at any curb ramp. Handrails shall extend at least 12 inches (305 mm) beyond the top and bottom of any ramp run.

EXCEPTION: Ramps having a rise less than or equal to 6 inches (152 mm), or a run less than or equal to 72 inches (1830 mm), need not have handrails.

1106.8.6 Exterior ramps. Exposed ramps and their approaches shall be constructed to prevent the accumulation of water on walking surfaces.

1106.8.7 Edge protection. Any portion of the edge of a ramp with a slope greater than 1 vertical in 20 horizontal, or landing which is more than 1/2 inch (13 mm) above the adjacent grade or floor, shall be provided with edge protection in accordance with the following:

1. Walls and Curbs. When used, walls or curbs shall be not less than 2 inches (51 mm) in height above the surface of the accessible route of travel.

2. Railings. When used, railings shall comply with Section 1106.8.5 and also shall have one of the following features:

2.1. An intermediate rail mounted 17 to 19 inches (430 to 485 mm) above the ramp or landing surface, or

2.2. A guardrail complying with Section 509.

1106.9 Stairways.

1106.9.1 General. Stairways required to be accessible shall comply with Section 1003.3.3 and provisions of this section.

1106.9.2 Open risers. Open risers shall not be permitted.

EXCEPTION: Stairways in Group R, Division 1 apartment buildings may have open risers.

1106.9.3 Nosings. Stair nosings shall be flush, slip-resistant, and rounded to a radius of 1/2 inch (13 mm) maximum. Risers shall be sloped, or the underside of the nosing shall have an angle of not less than 60 degrees from the horizontal. Nosings shall project no more than 1-1/2 inches (38 mm).

1106.9.4 Exterior stairways. Exposed stairways and their approaches shall be constructed to prevent the accumulation of water on walking surfaces.

1106.10 Doors.

1106.10.1 General. Doors required to be accessible shall comply with Section 1003.3.1 and with provisions of this section. For the purpose of this section, gates shall be considered to be doors. An accessible gate or door shall be provided adjacent to any turnstile or revolving door. Where doorways have two independently operated door leaves, then at least one leaf shall comply with this section.

1106.10.2 Clear width. Doors shall be capable of being opened so that the clear width of the opening is not less than 32 inches (815 mm).

EXCEPTION: Doors not requiring full user passage, such as shallow closets, may have a clear opening of not less than 20 inches (510 mm).

1106.10.3 Maneuvering clearances at doors. Except as provided in Section 1106.27, all doors shall have minimum maneuvering clearances as follows:

1. For a forward approach, where a door must be pulled to be opened, an unobstructed floor space shall extend at least 18 inches (455 mm) beyond the strike jamb and extend at least 60 inches (1525 mm) perpendicular to the doorway.

2. For a forward approach, where a door must be pushed to be opened and is equipped with a closer and a latch, an unobstructed floor space shall extend at least 12 inches (305 mm) beyond the strike jamb and extend at least 48 inches (1220 mm) perpendicular to the doorway.

3. For a forward approach, where a door must be pushed to be opened and is not equipped with a closer and a latch, an unobstructed floor space shall be at least the width of the doorway and extend at least 48 inches (1220 mm) perpendicular to the doorway.

4. For a hinge side approach, where a door must be pulled to be opened, an unobstructed floor space shall extend at least 36 inches (915 mm) beyond the latch side of the door and at least 60 inches (1525 mm) perpendicular to the doorway, or shall have an unobstructed floor space that extends at least 42 inches (1065 mm) beyond the latch side of the door and at least 54 inches (1370 mm) perpendicular to the doorway.

5. For a hinge side approach, where a door must be pushed to be opened and is not equipped with both a closer and a latch, an unobstructed floor space, measured from the latch side, shall extend across the width of the doorway and beyond the hinge side of the door for a total width of not less than 54 inches (1370 mm); and at least 42 inches (1065 mm) perpendicular to the doorway.

6. For a hinge side approach, where a door must be pushed to be opened and is equipped with both latch and closer, an unobstructed floor space, measured from the latch side, shall extend across the width of the doorway and beyond the hinge side of the door for a total width of not less than 54 inches (1370 mm); and at least 48 inches (1220 mm) perpendicular to the doorway.

7. For a latch side approach, where a door must be pulled to be opened and is equipped with a closer, an unobstructed floor space shall extend at least 24 inches (610 mm) beyond the latch side of the door and at least 54 inches (1370 mm) perpendicular to the doorway.

8. For a latch side approach, where a door must be pulled to be opened and is not equipped with a closer, an unobstructed floor space shall extend at least 24 inches (610 mm) beyond the latch side of the door and at least 48 inches (1220 mm) perpendicular to the doorway.

9. For a latch side approach, where a door must be pushed to be opened and is equipped with a closer, an unobstructed floor space shall extend at least 24 inches (610 mm) beyond the latch side of the door and at least 48 inches (1370 mm) perpendicular to the doorway.

10. For a latch side approach, where a door must be pushed to be opened and is not equipped with a closer, an unobstructed floor space shall extend at least 24 inches (610 mm) parallel to the doorway, beyond the latch side of the door and at least 42 inches (1065 mm) perpendicular to the doorway.

11. For a forward approach, to a sliding or folding door, an unobstructed floor space shall extend the same width as the door opening and at least 48 inches (1220 mm) perpendicular to the doorway.

12. For a slide side approach to a sliding or folding door, an unobstructed floor space, measured from the latch side, shall extend across the width of the doorway and beyond the slide side of the door for a total width of not less than 54 inches (1370 mm); and at least 42 inches (1065 mm) perpendicular to the doorway.

13. For a latch side approach to a sliding or folding door, an unobstructed floor space shall extend at least 24 inches

(610 mm) beyond the latch side of the door and at least 42 inches (1065 mm) perpendicular to the doorway.

14. Where two doors are in series, the minimum distance between two hinged or pivoted doors shall be 48 inches (1220 mm), in addition to any area needed for door swing. Doors in series shall swing either in the same direction, or away from the space between the doors.

15. All doors in alcoves shall comply with the requirement for a forward approach.

1106.10.4 Thresholds at doors. Thresholds at doors shall comply with Section 1106.6.

EXCEPTION: In dwelling units, exterior doors other than the accessible entrance to a dwelling unit, may be sliding doors with thresholds not exceeding 3/4 inch (19 mm).

1106.10.5 Automatic and power-assisted doors. Door-closers or power-operators shall be operable as required by Section 1003.3.1.2.

EXCEPTION: Floor pad or electric eye actuated power-operators.

All power-operated doors shall remain in the fully open position for not less than 6 seconds before closing. Touch switches shall be mounted 36 inches (915 mm) above the floor and not less than 18 inches (455 mm), nor more than 36 inches (915 mm), horizontally from the nearest point of travel of the moving door. Other power-operated doors must be actuated from a location not less than 36 inches (915 mm) from the nearest point of travel of the moving door. Power-operated doors shall automatically reopen when they encounter an obstruction other than the strike jamb.

1106.10.6 Door closers. Where provided, door closers shall be adjusted to close from an open position of 70 degrees to a point 3 inches (76 mm) from the latch, in not less than 3 seconds, when measured to the leading edge of the door.

1106.10.7 Vision panels. Where a door contains one or more vision panels, the bottom of the glass of at least one panel, shall be not more than 43 inches (1091 mm) above the floor.

1106.11 Bathrooms, Toilet Rooms, Bathing Facilities, and Shower Rooms.

1106.11.1 General. Bathrooms, toilet rooms, bathing facilities, and shower rooms shall be designed in accordance with this section. For dwelling units, see also Section 1106.27.

1106.11.2 Unobstructed floor space. An unobstructed floor space shall be provided within bathrooms, toilet rooms, bathing facilities, and shower rooms of sufficient size to inscribe a circle with a diameter not less than 60 inches (1525 mm). Doors in any position may encroach into this space by not more than 12 inches (305 mm). The clear floor spaces at fixtures, the accessible route of travel, and the unobstructed floor space may overlap.

1106.11.3 Wheelchair accessible toilet stalls.

1106.11.3.1 Dimensions. Wheelchair accessible toilet stalls shall be at least 60 inches (1525 mm) in width. Where wall-hung water closets are installed, the depth of the stall shall be not less than 56 inches (1420 mm). Where floor-mounted

water closets are installed, the depth of the stall shall be not less than 59 inches (1500 mm). Entry to the compartment shall have a clear width of 32 inches (815 mm). Toilet stall doors shall not swing into the clear floor space required for any fixture. Except for door swing, a clear unobstructed access not less than 48 inches (1220 mm) in width shall be provided to toilet stalls.

EXCEPTION: Partitions may project not more than one inch (25 mm), in the aggregate, into the required width of the stall.

1106.11.3.2 Toe clearances. In any toilet stall, the front partition and at least one side partition shall provide a toe clearance of at least 9 inches (230 mm) above the floor.

EXCEPTION: Toe clearance is not required in a stall with a depth greater than 60 inches (1525 mm).

1106.11.3.3 Door hardware. Doors of accessible toilet stalls shall comply with Section 1106.3.

1106.11.4 Ambulatory accessible toilet stalls. Ambulatory accessible toilet stalls shall be at least 36 inches (915 mm) in width, with an outward swinging, self-closing door. Grab bars shall be installed on each side of the toilet stall and shall comply with Sections 1106.11.5.3 and 1106.11.11.

1106.11.5 Water closets.

1106.11.5.1 Clear floor space. The lateral distance from the center line of the water closet to the nearest obstruction, excluding grab bars, shall be 18 inches (455 mm) on one side and not less than 42 inches (1065 mm) on the other side. In other than stalls, a clear floor space of not less than 32 inches (815 mm), measured perpendicular to the wall on which the water closet is mounted, shall be provided in front of the water closet.

EXCEPTION: In other than a toilet stall, a lavatory may be located within the clear floor space required for a water closet provided that knee and toe clearances for the lavatory comply with Section 1106.11.7, below, and:

1. In Type B dwelling units the edge of the lavatory shall be located not less than 15 inches (380 mm) from the centerline of the water closet; or,
2. In all other occupancies the edge of the lavatory shall be located not less than 18 inches (455 mm) from the centerline of the water closet.

1106.11.5.2 Height. The height of water closets shall be a minimum of 17 inches (430 mm) and a maximum of 19 inches (485 mm) measured to the top of the seat. Seats shall not be sprung to return to a lifted position.

1106.11.5.3 Grab bars. Grab bars shall be installed on one side and at the back of the water closet. The top of grab bars shall be not less than 33 inches (840 mm) and not more than 36 inches (915 mm) above and parallel to the floor. Grab bars located at the side shall be a minimum 42 inches (1065 mm) in length located not more than 12 inches (305 mm) from the rear wall and extending at least 54 inches (1370 mm) from the rear wall. Grab bars located at the back shall be a minimum of 36 inches (915 mm) in length and shall extend at least 12 inches (305 mm) beyond the center of the water closet toward the side wall and at least 24 inches (610 mm) toward the open side of the water closet. Grab bars located at the back shall be mounted not more than 9 inches (230 mm) behind the water closet seat. See also Section 1106.11.11.

1106.11.5.4 Flush controls. Flush controls shall be mounted for use from the wide side of the water closet area and not more than 44 inches (1118 mm) above the floor. Flush valves shall comply with Section 1106.3.

1106.11.5.5 Dispensers and receptacles. Toilet paper and other dispensers or receptacles shall be installed within easy reach of the water closet, and shall not interfere with unobstructed floor space or grab bar utilization.

1106.11.6 Urinals. A clear floor space measuring 30 inches (760 mm) in width by 48 inches (1220 mm) in depth shall be provided in front of urinals to allow for forward approach. Urinal shields shall have a clear space between them of not less than 29 inches (737 mm) and shall not extend farther than the front edge of the urinal rim. Urinals shall be stall-type or wall-hung with an elongated rim at a maximum of 17 inches (430 mm) above the floor. Flush controls shall be mounted not more than 44 inches (1118 mm) above the floor. Flush valves shall comply with Section 1106.3.

1106.11.7 Lavatories and sinks.

1106.11.7.1 Clear floor space. A clear floor space not less than 30 inches (760 mm) in width by 48 inches (1220 mm) in depth shall be provided in front of lavatories and sinks to allow a forward approach. The clear floor space may include knee and toe clearances not to exceed 19 inches (485 mm) extending under the lavatory or sink.

1106.11.7.2 Height. Lavatories and sinks shall be mounted with the rim or counter surface no higher than 34 inches (865 mm) above the finished floor.

1106.11.7.3 Knee and toe clearances.

1106.11.7.3.1 Lavatories. The total depth of the clear space beneath a lavatory shall be not less than 17 inches (430 mm), of which toe clearance shall be not more than 6 inches (152 mm) of the total depth. Knee clearance shall be not less than 29 inches (237 mm) in height and 30 inches (760 mm) in width.

1106.11.7.3.2 Sinks. Knee clearance not less than 27 inches (685 mm) in height, 30 inches (760 mm) in width, and 19 inches (485 mm) in depth shall be provided underneath sinks.

1106.11.7.4 Exposed pipes and surfaces. Hot water and drain pipes exposed under lavatories and sinks shall be insulated or otherwise covered. There shall be no sharp or abrasive surfaces under lavatories or sinks.

1106.11.7.5 Faucets. Faucet control handles shall be located not more than 17 inches (430 mm) from the front edge of the lavatory, sink or counter, and shall comply with Section 1106.3. Self-closing valves shall remain open for at least 10 seconds per operation.

1106.11.7.6 Sink depth. Sinks shall be not more than 6-1/2 inches (165 mm) in vertical depth.

1106.11.8 Mirrors, dispensers, and other fixtures. Mirrors or shelves shall be installed so that the bottom of the mirror or the top of the shelf is within 40 inches (1015 mm) of the floor.

Drying equipment, towel or other dispensers, and disposal fixtures shall be mounted so as to not exceed 40 inches (1015 mm) above the finished floor to any rack, operating controls, receptacle or dispenser.

1106.11.9 Bathtubs.

1106.11.9.1 Clear floor space. A clear floor space not less than 60 inches (1525 mm) in length shall be provided along the tub. Where the required seat is located at the end of the tub, the clear floor space shall be not less than 75 inches (1905 mm) in length. The clear floor space shall be not less than 30 inches (760 mm) in width where access to the space is parallel to the tub and not less than 48 inches (1220 mm) in width where access to the space is at right angles to the tub.

A lavatory which complies with Section 1106.11.7, above, may be located in the clear floor space for the tub.

Where a seat is provided and a lavatory is located in the clear floor space for the tub, the lavatory shall be located at the end of the tub adjacent to the controls.

1106.11.9.2 Seats. An in-tub seat or a seat at the end of the tub shall be provided. In-tub seats shall be portable and removable, not less than 12 inches (305 mm) in width, and extend the full width of the tub. Seats at the end of the tub shall be constructed flush with the top of the tub and shall extend not less than 15 inches (380 mm) from the end of the tub. Seats shall be mounted securely and shall not slip during use.

1106.11.9.3 Grab bars. All required grab bars shall be installed parallel to the floor. Lower grab bars shall be installed centered 9 inches (230 mm) above the tub rim. Upper or single grab bars shall be installed centered not less than 33 inches (840 mm) and not more than 36 inches (915 mm) above the floor of the clear space.

Where a tub has a seat at the end, two grab bars not less than 48 inches (1220 mm) in length shall be installed on the wall opposite the clear floor space. One end of each grab bar shall terminate where the tub abuts the seat.

Where a tub has an in-tub seat, two grab bars, not less than 24 inches (610 mm) in length, shall be installed on the wall opposite the clear floor space. The grab bars shall extend to not less than 24 inches (610 mm) from one end of the tub and not less than 12 inches (305 mm) from the other end. One grab bar shall be installed on the wall at the end of the tub opposite the drain, extending at least 12 inches (305 mm) from the clear floor space.

For all bathtubs, one grab bar shall be installed on the wall at the end of the tub nearest the drain, extending at least 24 inches (610 mm) from the clear floor space.

1106.11.9.4 Controls and fixtures. Faucets and other controls shall be located above the tub rim and below the grab bars, shall be offset laterally from the clear floor space between the open edge of the tub and the mid-point of the tub and shall comply with Section 1106.3.

A shower spray unit, with a hose at least 60 inches (1525 mm) long, that can be used as a fixed shower head or as a hand-held shower, shall be provided.

1106.11.9.5 Bathtub enclosures. Where provided, enclosures for bathtubs shall not obstruct controls or obstruct transfer from wheelchairs onto bathtub seats or into tubs. Bathtub enclosures shall not have tracks mounted on the tub rim.

1106.11.10 Shower stalls.

1106.11.10.1 Configuration. Shower stalls shall have one of the following configurations:

1. Transfer shower stalls shall be 36 inches by 36 inches (915 by 915 mm), nominal, and shall have a seat; or,
2. Roll-in shower stalls shall be not less than 30 inches (760 mm) in depth by 60 inches (1525 mm) in length.

1106.11.10.2 Clear floor space. A clear floor space shall be provided adjacent to shower stalls.

1. For transfer shower stalls, a clear floor space not less than 48 inches (1220 mm) in length, parallel to the open side of the shower stall, and not less than 36 inches (915 mm) in width, perpendicular to the open edge of the shower stall, shall be located so as to extend at least 12 inches (305 mm) beyond the wall on which the seat is mounted.

2. For roll-in shower stalls, a clear floor space not less than 60 inches (1525 mm) in length, parallel to the open edge of the shower stall, and not less than 36 inches (915 mm) in width, perpendicular to the open edge of the shower stall, shall be provided. A lavatory which complies with Section 1106.11.7, above, may be located within one end of the clear floor space. Where a seat is provided in the shower, a lavatory may be located only at the opposite end of the clear space.

1106.11.10.3 Seats. Transfer shower stalls shall be provided with a folding or nonfolding seat located on the wall opposite the shower controls.

Roll-in shower stalls shall be provided with a folding seat located on the wall adjacent to the shower controls.

EXCEPTION: Roll-in shower stalls located in occupancies other than hotels, lodging houses and congregate residences need not be provided with a seat.

The seat shall be mounted not less than 17 inches (430 mm) and not more than 19 inches (485 mm) above the floor. The seat shall be mounted not more than 1-1/2 inches (38 mm) from the shower walls. The leading edge of the seat may be set back not more than 1-1/2 inches (38 mm) from the leading edge of the shower stall.

The seat shall be L-shaped and shall extend the full depth of the stall. The section of the seat adjacent to the wall opposite the clear floor space shall be at least 22 inches (560 mm) and not more than 23 inches (585 mm) wide, measured from the wall on which the seat is mounted. That section of the seat shall extend not less than 14 inches (355 mm) but not more than 15 inches (380 mm), measured from the wall opposite the clear floor space. The remaining portion of the seat shall

be not less than 15 inches (380 mm) and not more than 16 inches (405 mm) wide, measured from the wall on which the seat is mounted, and shall extend the remaining depth of the stall.

1106.11.10.4 Grab bars. All required grab bars shall be installed parallel to the floor. All grab bars shall be installed not less than 33 inches (840 mm) and not more than 36 inches (915 mm) above the floor of the adjacent clear space.

For transfer shower stalls, a grab bar, not less than 18 inches (455 mm) in length, shall be installed on the wall opposite the clear floor space. One end of the grab bar shall terminate at the wall opposite the seat. A grab bar not less than 27 inches (685 mm) in length shall also be installed on the wall opposite the seat.

For roll-in shower stalls, grab bars shall be provided on all permanent stall walls. Grab bars located on either end of the stall shall be not less than 27 inches (685 mm) in length. The grab bar located opposite the clear space shall be not less than 48 inches (1220 mm) in length.

1106.11.10.5 Controls and fixtures. Faucets and other controls shall be located on the same wall as the shower spray unit, and shall be installed not less than 38 inches (965 mm) or more than 48 inches (1220 mm) above the shower floor and shall comply with Section 1106.3. In addition:

1. For transfer shower stalls, the controls shall be located on the wall opposite the shower seat. The controls shall be located within 18 inches (455 mm) of the open side of the shower stall.

2. For roll-in shower stalls equipped with seats, the controls shall be mounted on the wall adjacent to the seat not more than 27 inches (685 mm) from the wall where the seat is mounted. For roll-in shower stalls without seats, the controls may be located on any wall. Where the controls are located on the back wall, they shall be located not more than 27 inches (685 mm) from a side wall.

A shower spray unit, with a hose at least 60 inches (1525 mm) long, that can be used as a fixed shower head or as a hand-held shower, shall be provided.

EXCEPTION: In unmonitored facilities where vandalism is a consideration, a fixed shower head may be installed not more than 48 inches (1220 mm) above the stall floor.

1106.11.10.6 Thresholds. In transfer shower stalls, thresholds shall be flush or beveled with a maximum edge height of 1/2 inch (13 mm), and a maximum slope of not more than 1 vertical in 2 horizontal.

Thresholds in roll-in shower stalls shall be level with the adjacent clear space.

1106.11.10.7 Shower enclosures. Where provided, enclosures for shower stalls shall not obstruct controls or obstruct transfer from wheelchairs onto shower seats.

1106.11.11 Structural requirements for grab bars, and tub and shower seats.

1106.11.11.1 General. All grab bars, and tub and shower seats required to be accessible, shall comply with this section.

1106.11.11.2 Size and spacing of grab bars. Grab bars shall have an outside diameter of not less than 1-1/4 inch (32 mm) nor more than 1-1/2 inches (38 mm) and shall provide a clearance of 1-1/2 inches (38 mm) between the grab bar and the wall.

1106.11.11.3 Structural strength. The structural strength of grab bars, tub and shower seats, fasteners and mounting devices shall meet the following specification:

1. Bending stress in a grab bar or seat induced by the maximum bending moment from the application of 300 pounds (1334 N) shall be less than the allowable stress for the material of the grab bar or seat.

2. Shear stress induced in a grab bar or seat by the application of 300 pounds (1334 N) shall be less than the allowable shear stress for the material of the grab bar or seat. If the connection between the grab bar or seat and its mounting bracket or other support is considered to be fully restrained, then direct and torsional shear stresses shall be totaled for the combined shear stress, which shall not exceed the allowable shear stress.

3. Shear force induced in a fastener or mounting device from the application of 300 pounds (1334 N) shall be less than the allowable lateral load of either the fastener or mounting device or the supporting structure, whichever is the smaller allowable load.

4. Tensile force induced in a fastener by a direct tension force of 300 pounds (1334 N) plus the maximum moment from the application of 300 pounds (1334 N) shall be less than the allowable withdrawal load between the fastener and the supporting structure.

1106.11.11.4 Special hazards. A grab bar and any wall or other surface adjacent to it shall be free of any sharp or abrasive elements. Edges shall have a minimum radius of 1/8 inch (3 mm).

1106.12 Kitchens.

1106.12.1 Clear floor space. An unobstructed floor space shall be provided within kitchens of sufficient size to inscribe a circle with a diameter not less than 60 inches (1525 mm). Doors in any position may encroach into this space by not more than 12 inches (305 mm). The clear floor spaces at fixtures, the accessible route of travel, and the unobstructed floor space may overlap.

1106.12.2 Counter surfaces and shelving. Within Type A dwelling units, a counter surface, a minimum of 30 inches (760 mm) wide by 24 inches (610 mm) deep, shall be provided at a maximum height of 34 inches (865 mm), with a knee space beneath at least 27 inches (685 mm) in height.

In other than dwelling units, at least 50 percent of shelf space in cabinets, refrigerators and freezers shall be within the reach ranges specified in Section 1106.2.4.

1106.13 Water Fountains.

1106.13.1 Clear floor space. Wall- and post-mounted cantilevered units shall have a minimum clear floor space in front of the unit, of 30 inches (760 mm) in width by 48 inches (1220 mm) in depth to allow a forward approach.

Free-standing or built-in units not having a clear space beneath them shall have an adjacent clear floor space at least 30 inches (760 mm) in depth by 48 inches (1220 mm) in width in order to allow a person in a wheelchair to make a parallel approach to the unit.

1106.13.2 Knee space. Wall- and post-mounted cantilevered units shall have knee space in accordance with Section 1106.2.4.3. The knee space shall be not less than 17 inches (430 mm) nor more than 19 inches (485 mm) in depth.

1106.13.3 Spout location. Spouts shall be located not more than 36 inches (915 mm) above the floor or ground surface. Spouts shall be located at the front of the unit and shall direct a water flow not less than 4 inches (102 mm) in height, in a trajectory parallel to the front of the unit. Recessed units shall be installed such that the spout is not recessed beyond the plane of the wall.

1106.13.4 Controls. Controls shall be located not more than 6 inches (152 mm) from the front of the unit and shall comply with Section 1106.3. The force required to activate the control shall not exceed 5 pounds (22.2 N).

1106.13.5 Water fountains in alcoves. Where a unit is installed in an alcove greater than 8 inches (205 mm) in depth, the alcove shall be not less than 48 inches (1220 mm) in width. A minimum 24 inches (610 mm) of clear space shall be provided from the spout to the nearest side wall of the alcove.

1106.14 Telephones.

1106.14.1 Clear floor or ground space. A clear floor or ground space, not less than 30 inches (760 mm) by 48 inches (1220 mm), that allows either a forward or parallel approach, shall be provided in front of telephones. Bases, enclosures and fixed seats shall not project into the clear floor space.

Where parallel approach is provided, any shelf or enclosure shall not project farther than 10 inches (255 mm) beyond the face of the telephone.

Where a forward approach is provided, any shelf shall not project farther than 20 inches (510 mm) beyond the face of the telephone; any enclosure panels shall be a minimum 30 inches (760 mm) apart, and where less than 36 inches (915 mm) apart, shall project no more than 24 inches (610 mm) beyond the face of the phone.

1106.14.2 Height. The highest operable part of a telephone shall be within the reach ranges specified in Section 1106.2.4.

1106.14.3 Equipment for persons with hearing impairments. Telephones shall be equipped with volume controls and shall be hearing aid compatible. Volume controls shall be capable of increasing volume not less than 12 dbA nor more than 18 dbA above normal.

EXCEPTION: Where an automatic reset is provided, 18 dbA may be exceeded.

1106.14.4 Controls. Telephones shall have push-button controls where service for such equipment is available.

1106.14.5 Cord length. The cord from the telephone to the handset shall be not less than 29 inches (737 mm) in length.

1106.14.6 Text telephones. Text telephones shall be permanently affixed within, or adjacent to, the telephone enclosure. Where an acoustic coupler is used, the telephone cord shall be sufficiently long to allow connection of the text telephone and the telephone receiver.

1106.14.7 Shelf and electrical outlet. Shelves and an electrical outlet shall be located within or adjacent to the telephone enclosure. The shelf shall be not less than 10 inches by 10 inches (255 mm by 255 mm) in dimension, with a vertical clearance above the shelf of not less than 6 inches (152 mm). The telephone handset shall be capable of being placed flush on the surface of the shelf.

1106.15 Alarms.

1106.15.1 Audible alarms. Audible alarms shall produce a sound in accordance with the Fire Code.

1106.15.2 Visible alarms. Visible alarm signal appliances shall be integrated into the building or facility alarm system. Where single-station audible alarms are provided, single-station visible alarm signals shall be provided.

EXCEPTION: Visible alarms are not required in Group R, Division 1 apartment buildings.

Visible alarm system designs shall comply with the requirements in ANSI A117.1, 1998 edition, or NFPA 72, 1999 edition.

1106.15.3 Access to manual fire alarm systems. Manual fire alarm devices shall be mounted not more than 54 inches (1370 mm) above the floor where a parallel approach is provided.

1106.16 Signage.

1106.16.1 Symbols.

1106.16.1.1 International Symbol of Access. The International Symbol of Access shall be as shown below:



1106.16.1.2 Text telephones. Text telephones required by Section 1105.4.2 shall be identified by the International Text Telephone Symbol as shown below:

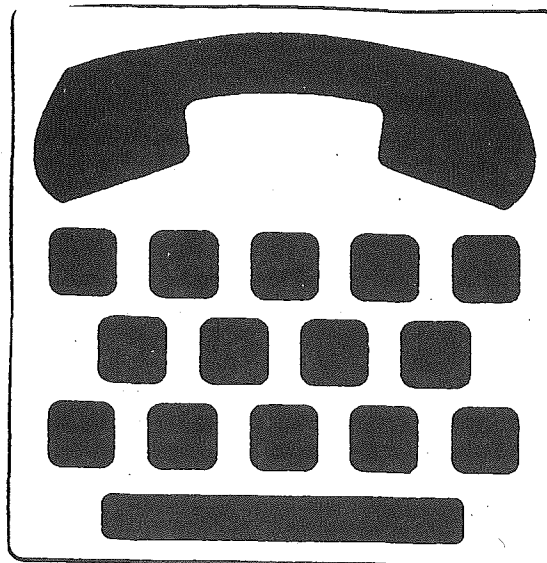

1106.16.1.3 Assistive listening systems. Permanently installed assistive listening systems that are required by Section 1103.1.2.2 shall be identified by the International Symbol of Access for Hearing Loss as shown below:



1106.16.1.4 Volume control telephones. Telephones required by Section 1105.4.2 to have volume controls shall be identified by a handset containing a depiction of a telephone handset with radiating sound waves.

1106.16.2 Mounting location and height. Signs shall be installed on the wall adjacent to the latch side of the door. Signs shall be centered at 60 inches (1525 mm) above the finished floor. Mounting location for such signage shall be such that a person may approach within 3 inches (76 mm) of signage without encountering protruding objects or standing within the swing of a door.

1106.16.3 Finish and color. Characters and symbols shall have a high contrast with their background. The character and background of interior signs shall be eggshell, matte, or other nonglare finish.

All interior and exterior signs depicting the International Symbol of Access shall be white on a blue background.

1106.16.4 Character proportion and height. Letters and numbers on signs shall have a width-to-height ratio between 3:5 and 1:1 and a stroke-width-to-height ratio between 1:5 and 1:10.

Characters and numbers on signs shall be sized according to the viewing distance from which they are to be read. The minimum character height for signs that are suspended or projected overhead is 3 inches (76 mm) for upper case letters. Lower case letters are permitted.

1106.16.5 Raised and Braille characters and pictorial symbol signs (pictograms).

1106.16.5.1 Raised characters and symbols. Characters and symbols on tactile signs shall be raised at least 1/32 inch (.8 mm). Raised characters and symbols shall be simple type face upper case characters. Raised characters and symbols shall be between 5/8 inch (16 mm) and 2 inches (51 mm) in height. Raised characters shall be accompanied by Braille in accordance with this section.

1106.16.5.2 Braille. Braille shall be separated from the corresponding raised characters or symbols. Braille shall be Grade 2.

1106.16.5.3 Pictograms. Where provided, pictograms shall be accompanied by the equivalent verbal description placed directly below the pictogram. The border dimension of the pictogram shall be not less than 6 inches (152 mm) in height.

1106.17 Detectable Warnings. Detectable warnings on walking surfaces shall consist of raised truncated domes having a diameter of 0.9 inches (23 mm) nominal, a height of 0.2 inches (5 mm) nominal, and a center-to-center spacing of 2.35 inches (60 mm) nominal, or be an approved alternate, and shall contrast visually and tactilely with adjoining surfaces.

1106.18 Storage, Shelving and Display Units.

1106.18.1 Clear floor space. Storage, shelving and display units shall have a clear floor space, not less than 30 inches (760 mm) by 48 inches (1220 mm), that allows for either a forward or parallel approach.

1106.18.2 Height. Accessible storage, shelving and display units shall be within the reach ranges specified in Section 1106.2.4. Clothes rods shall be not more than 54 inches (1370 mm) above the floor.

1106.19 Seating, Tables, and Sinks.

1106.19.1 Clear floor space. Sinks and seating spaces at tables shall have a clear floor space of not less than 30 inches (760 mm) by 48 inches (1220 mm), that allows forward approach. The clear floor space shall not overlap knee space by more than 19 inches (483 mm).

1106.19.2 Knee clearances. Knee spaces at tables, counters, and sinks shall be provided in accordance with Section 1106.2.4.3. In addition, the depth of the knee space shall be not less than 19 inches (483 mm). No projection which might obstruct the arm of a wheelchair may intrude into this clearance, within 24 inches (610 mm) horizontally from the table edge.

1106.19.3 Height. The tops of tables and sinks shall be not less than 28 inches (710 mm) nor more than 34 inches (865 mm) in height above the floor or ground.

1106.20 Aisles. All aisles required to be accessible, including check out aisles, food service lines, and aisles between fixed tables, shall be not less than 36 inches (915 mm) in width.

1106.21 Assembly Areas.

1106.21.1 Wheelchair spaces.

1106.21.1.1 Location. Wheelchair spaces shall be an integral part of any fixed seating plan and shall be dispersed throughout the seating area. Spaces shall adjoin an accessible route of travel that also serves as a means of egress and shall be located to provide lines of sight comparable to those for all viewing areas.

EXCEPTION: Accessible viewing positions may be clustered for bleachers, balconies and other areas having sight lines that require slopes of greater than 5 percent. Equivalent accessible viewing positions may be located on levels having accessible egress.

1106.21.1.2 Size. Wheelchair spaces shall be not less than 33 inches (840 mm) in width. Where forward or rear approach is provided, wheelchair spaces shall be not less than 48 inches (1220 mm) in depth. Where only side approach is provided, wheelchair spaces shall be not less than 60 inches (1525 mm) in depth.

1106.21.1.3 Surfaces. The ground or floor surfaces at wheelchair locations shall be level and shall comply with Section 1106.7.

1106.21.2 Placement of assistive listening systems. Where an assistive listening system serves individual fixed seats, such seats shall have a clear line of sight and shall be located not more than 50 feet (15 m) from the stage or performance area.

1106.22 Restaurants and Cafeterias.

1106.22.1 Aisles. Aisles to fixed tables required to be accessible shall comply with Section 1106.20.

1106.22.2 Food service lines.

1106.22.2.1 Clear floor space. Food service lines shall comply with Section 1106.20.

1106.22.2.2 Height. Tray slides shall be mounted not more than 34 inches (865 mm) in height above the floor.

1106.22.2.3 Counters and bars. Where service of food or drink is provided at counters more than 34 inches (865 mm) in height, to customers seated on stools or standing, a portion of the main counter shall be provided in compliance with Section 1106.19, or service shall be available at accessible tables within the same area.

1106.22.2.4 Tableware and condiment areas. Self-service shelves and dispensing devices for tableware, dishware, condiments, food, and beverages shall be installed to comply with Section 1106.18.

1106.23 Patient bedrooms. Each patient bedroom shall be designed and constructed to provide space for a 180-degree turn that complies with Section 1106.2.2. Each patient room shall have a minimum clear floor space not less than 36 inches (915 mm) on each side of any bed.

1106.24 Customer Service Facilities.

1106.24.1 Dressing and fitting rooms.

1106.24.1.1 Clear floor space. Each dressing and fitting room shall have a clear floor space complying with Section 1106.2.

EXCEPTION: Dressing and fitting rooms that are entered through a curtained opening need not comply with Section 1106.2.2.

1106.24.1.2 Doors. All doors to accessible dressing and fitting rooms shall comply with Section 1106.10.

1106.24.1.3 Benches. Every accessible dressing or fitting room shall have a bench installed adjacent to the longest wall in the room. The bench shall be not less than 24 inches (610 mm) in width and 48 inches (1220 mm) in length, and shall be mounted not less than 17 inches (430 mm) nor more than 19 inches (483 mm) above the finished floor.

Clear floor space shall be provided adjacent to the bench to allow for parallel transfer, and the structural strength of the bench shall comply with Section 1106.11.11.3.

Where benches are installed in dressing and fitting rooms adjacent to showers, swimming pools, or other wet locations, water shall not accumulate upon the surface of the bench and the bench shall have a slip-resistant surface.

1106.24.1.4 Mirrors. Where provided, mirrors in accessible dressing and fitting rooms shall be not less than 18 inches (455 mm) in width by 54 inches (1370 mm) in height and shall be mounted opposite the bench.

1106.24.2 Counters and windows. Where counters are required to be accessible, the accessible portion shall be not less than 36 inches (915 mm) in length and not more than 36 inches (915 mm) in height above the finished floor.

Where accessible windows are required, they shall be no more than 36 inches (915 mm) in height above the finished floor.

EXCEPTION: An auxiliary counter with a maximum height of 36 inches (915 mm) is installed in close proximity to the main counter.

1106.24.3 Check-out aisles. The width of accessible check-out aisles shall comply with Section 1106.20. Counters in accessible check-out aisles shall be not more than 38 inches (965 mm) in height, and the top of the raised edge of the counter shall not exceed 40 inches (1015 mm) in height above the finished floor.

Accessible check-out aisles shall be identified by the International Symbol of Access in accordance with Section 1106.16.1.1.

1106.25 Libraries.

1106.25.1 Reading and study areas. At least 5 percent, or a minimum of one, of each element of fixed seating, tables, or study carrels shall comply with Section 1106.19. Clearances between fixed accessible tables and study carrels shall comply with Section 1106.20.

1106.25.2 Check-out areas. At least one lane at each check-out area shall comply with Section 1106.20. Any traffic control or book security gates or turnstiles shall comply with Section 1106.10.

1106.25.3 Card catalogs, magazine displays and stacks.

1106.25.3.1 Aisles. Aisles between card catalogs, magazine displays or stacks shall comply with Section 1106.20.

1106.25.3.2 Height. Card catalogs or magazine displays shall have a reach height of not more than 54 inches (1370 mm) for side approach and not more than 48 inches (1220 mm) for forward approach.

Not all shelves in library stacks need be located within reach ranges required by Section 1106.2.4.

1106.26 Hotels and Congregate Residences.

1106.26.1 Clear floor space. Each sleeping room shall have a space complying with Section 1106.4.1, along both sides of each bed.

EXCEPTION: In rooms with two beds, only one 36 inch (915 mm) wide maneuvering space need be provided between the two beds.

1106.26.2 Accessible route of travel. An accessible route of travel complying with Section 1103.2.2 shall connect all accessible spaces and elements; including telephones, patios, terraces, balconies, carparks, garages or parking spaces; with all accessible sleeping rooms.

1106.26.3 Doors. Doors within all sleeping rooms, suites or other covered units shall comply with Section 1106.10.

1106.26.4 Storage. Where fixed or built-in storage is provided in accessible units, sleeping rooms, or suites; including cabinets, shelves, closets, and drawers; at least one of each type shall comply with Section 1106.18.

1106.26.5 Controls. All controls in accessible units, sleeping rooms, and suites shall comply with Section 1106.3.

1106.27 Dwelling Units.

1106.27.1 Type A and B dwelling units. Type A and B dwelling units shall comply with Section 1106.

EXCEPTIONS:

1. In a Type A accessible dwelling unit with two or more stories, access to other levels is not required if the accessible level complies with all requirements for Type A accessible dwelling units and that kitchen, toilet and bathing facilities, and at least one bedroom are provided on the accessible level.
2. Kitchens in Type B dwelling units need not comply with Section 1106.12.1, provided that:
 - 2.1. A clear space at least 30 inches by 48 inches (760 mm by 1220 mm) that allows parallel approach by a person in a wheelchair is provided at the range or cook top and sink, and either a parallel or forward approach is provided at all other appliances; and,
 - 2.2. In all other kitchens, clearance between all opposing counters, base cabinets, countertops, appliances, and walls shall be not less than 40 inches (1015 mm); and,
 - 2.3. In "U" shaped kitchens with a sink, range, or cooktop at the base of the "U", an unobstructed floor space of sufficient size to inscribe a circle with a diameter of not less than 60 inches (1525 mm) shall be provided.
3. Bathrooms in Type B dwelling units need not comply with Section 1106.11.2, provided that sufficient maneuvering space which is not less than 30 inches by 48 inches (760 by 1220 mm) is provided within the bathroom. Doors may swing into the clear floor space provided at any fixture, but shall not encroach on the required maneuvering space.

4. Doors in Type B dwelling units, other than the primary entry door, need not comply with Section 1106.10.3.

5. Mezzanines in Type A or B dwelling units need not be accessible.

6. Raised or sunken floors in Type B dwelling units need not be accessible, provided that they do not interfere with the accessible route of travel through the unit, and are not located in the kitchen or bathroom.

7. Counter surfaces in Type B dwelling units need not comply with Section 1106.12.2.

8. Within an individual dwelling unit in a building with an elevator, access to other levels is not required if the accessible level complies with all requirements for accessible dwelling units.

9. In Type B dwelling units, exterior deck, patio, or balcony surfaces may be no more than 4 inches (100 mm) below the floor level of the interior surface where the exterior surface is constructed of an impervious material such as concrete, brick, or flagstone.

10. Vanities or lavatories in Type A and B dwelling units may be located in the clear floor spaces as permitted in Section 1106.11.5.1.

11. Seats for bathtubs or showers are not required in Type B dwelling units.

12. In Type B dwelling units, the clear floor space for bathtubs or showers may be reduced to not less than 30 inches (760 mm) in width by 48 inches (1220 mm) in length.

13. Showers in Type B dwelling units shall be nominal 36 inches (915 mm) minimum by 36 inches (915 mm) minimum.

1106.27.2 Adaptable fixtures for dwelling units.

1106.27.2.1 Grab bars. Grab bars may be omitted in bathing and toilet facilities within Type A or B dwelling units, provided that all structural reinforcements for grab bar installation are provided in the appropriate locations in the adjoining walls.

1106.27.2.2 Kitchen counters. Cabinets or shelving may be installed beneath the counter space required by Section 1106.12.2, provided that such cabinetry or shelving is not permanent, and is easily removable.

1106.27.2.3 Lavatories. Cabinets or shelving may be installed beneath bathroom lavatories provided that such cabinetry or shelving is not permanent, and is easily removable.

1106.27.2.4 Signage. Parking signage required by Section 1107.3 need not be installed in spaces designated for accessible dwelling units.

[Statutory Authority: RCW 19.27.031, 19.27.074, 01-02-095, § 51-40-1106, filed 1/3/01, effective 7/1/01; 98-02-054, § 51-40-1106, filed 1/6/98, effective 7/1/98.]

WAC 51-40-1107 Section 1107—Parking facilities.**Section 1107.1 Accessible Parking Required.**

1107.1.1 General. For other than Group R, Division 1 apartment buildings, when parking lots or garage facilities are provided, accessible parking spaces shall be provided in accordance with Table No. 11-F.

1107.1.2 Inpatient and outpatient medical care facilities. For Group I, Division 1.1, 1.2 and 2 units and facilities specializing in the treatment of persons with mobility impairments on either an inpatient or outpatient basis, 20 percent of the parking spaces provided accessory to such units and facilities shall be accessible.

1107.1.3 Outpatient medical care facilities. For Group I, Division 1.1 and 1.2 Occupancies providing outpatient medical care facilities, 10 percent of the parking spaces provided accessory to such occupancies shall be accessible.

1107.1.4 Apartment buildings. For Group R, Division 1 apartment buildings where parking is provided, one accessible parking space shall be provided for each Type A dwelling unit and reserved for its occupants. In addition, where the total parking provided on a site exceeds 1 parking space per dwelling unit, not less than 2 percent, and in no case less than 1 space, of this additional parking shall be accessible.

1107.1.5 Van parking. For other than Group R, Division 1 apartment buildings, where accessible parking is required, one of every eight accessible parking spaces, or fraction thereof, shall be designed to be accessible to vans.

1107.1.6 Location of parking. Accessible parking spaces shall be located on the shortest possible accessible route of travel to an accessible building entrance. In facilities with multiple accessible building entrances with adjacent parking, accessible parking spaces shall be dispersed and located near the accessible entrances. Wherever practical, the accessible route of travel shall not cross lanes of vehicular traffic. Where crossing traffic lanes is necessary, the route of travel shall be designated and marked as a crosswalk.

EXCEPTION: In multilevel parking structures, all accessible van parking spaces may be located on the same level.

Where a parking facility is not accessory to a particular building, accessible parking spaces shall be located on the shortest accessible route to an accessible pedestrian entrance to the parking facility.

1107.2 Design and Construction.

1107.2.1 General. When accessible parking spaces are required by this section, they shall be designed and constructed in accordance with this section.

1107.2.2 Size. Parking spaces shall be not less than 96 inches (2440 mm) in width and shall have an adjacent access aisle not less than 60 inches (1525 mm) in width. Van accessible parking spaces shall have an adjacent access aisle not less than 96 inches (2440 mm) in width.

Where two adjacent spaces are provided, the access aisle may be shared between the two spaces. Boundaries of access aisles shall be marked so that the aisles will not be used as parking space.

1107.2.3 Vertical clearance. Where accessible parking spaces are required for vans, the vertical clearance shall be not less than 114 inches (2895 mm) at the parking space and along at least one vehicle access route to such spaces from site entrances and exits.

1107.2.4 Slope. Accessible parking spaces and access aisles shall be located on a surface with a slope not to exceed 1 vertical in 48 horizontal.

1107.2.5 Surface. Parking spaces and access aisles shall be firm, stable, smooth, and slip-resistant.

1107.3 Signs. Every parking space required by this section shall be identified by a sign, centered between 3 and 5 feet (915 mm and 1525 mm) above the parking surface, at the head of the parking space. The sign shall include the International Symbol of Access and the phrase "State Disabled Parking Permit Required".

Van accessible parking spaces shall have an additional sign mounted below the International Symbol of Access identifying the spaces as "Van Accessible."

EXCEPTION: Where all of the accessible parking spaces comply with the standards for van accessible parking spaces.

(See also Section 1106.27.2)

[Statutory Authority: RCW 19.27.031 and 19.27.074. 98-02-054, § 51-40-1107, filed 1/6/98, effective 7/1/98.]

WAC 51-40-1108 Section 1108—Passenger loading zones.

Section 1108.1 Location. Where provided, passenger loading zones shall be located on an accessible route of travel.

1108.2 Design and Construction.

1108.2.1 General. Passenger loading zones shall be designed and constructed in accordance with this section.

1108.2.2 Size. Passenger loading zones shall provide an access aisle not less than 60 inches (1525 mm) in width by 20 feet (6 m) in length with the long dimension abutting and parallel to: A: The vehicle space on one side; and B: an accessible route of travel on the other.

1108.2.3 Slope. Such zones shall be located on a surface with a slope not exceeding 1 vertical in 48 horizontal.

[Statutory Authority: RCW 19.27.031 and 19.27.074. 98-02-054, § 51-40-1108, filed 1/6/98, effective 7/1/98.]

PART III - ACCESSIBILITY FOR EXISTING BUILDINGS

WAC 51-40-1109 Section 1109—Scope.

Section 1109.1 General. The provisions of this part apply to renovation, alterations, and additions to existing buildings including those identified as historic buildings. This chapter includes minimum standards for removing architectural barriers, and providing and maintaining accessibility for persons with disabilities to existing buildings and their related facilities.

1109.2 Equivalent Facilitation. Departures from specific technical and scoping requirements of this part by the use of alternate methods are permitted where such methods will provide equivalent or greater access to, and usability of, the facility. Alternate methods shall permit individuals with disabilities to approach, enter, and use a site, building, facility or portion thereof; as easily, safely, conveniently, and independently as the specified method.

[Statutory Authority: RCW 19.27.031 and 19.27.074. 98-02-054, § 51-40-1109, filed 1/6/98, effective 7/1/98.]

WAC 51-40-1110 Section 1110—Definitions.

Section 1110. For the purpose of this part, certain terms are designated as follows:

ALTERATION is any change, addition, or modification in construction or occupancy.

ALTERATION, SUBSTANTIAL is any alteration, where the total cost of all alterations (including but not limited to electrical, mechanical, plumbing, and structural changes) for a building or facility within any 12-month period amounts to 60 percent or more of the appraised value.

PATH OF TRAVEL means a continuous, unobstructed way of pedestrian passage by means of which an altered area may be approached, entered, and exited, and which connects the altered area with an exterior approach (including sidewalks, streets, and parking areas), an entry to the facility, and other parts of the facility. For the purposes of this part, the term path of travel also includes restrooms, telephones, and water fountains serving the altered area.

TECHNICALLY INFEASIBLE means that an alteration has little likelihood of being accomplished because existing structural conditions would require removing or altering a load-bearing member which is an essential part of the structural frame, or because site constraints prohibit modification or addition of elements, spaces, or features which are in full and strict compliance with the minimum requirements for new construction and necessary to provide accessibility.

[Statutory Authority: RCW 19.27.031 and 19.27.074. 98-02-054, § 51-40-1110, filed 1/6/98, effective 7/1/98.]

WAC 51-40-1111 Section 1111—Additions.

Section 1111 Additions. New additions may be made to existing buildings without making the entire building comply, provided the new additions conform to the provisions of Part II of this chapter, except as follows:

1. **Entrances.** Where a new addition to a building or facility does not have an accessible entrance, at least one entrance in the existing building or facility shall be accessible.

2. **Accessible Route.** Where the only accessible entrance to the addition is located in the existing building or facility, at least one accessible route of travel shall be provided through the existing building or facility to all rooms, elements and spaces in the new addition which are required to be accessible.

3. **Toilet and Bathing Facilities.** Where there are no toilet rooms and bathing facilities in an addition and these facilities are provided in the existing building, then at least one toilet and bathing facility in the existing facility shall comply with Section 1106 or with Section 1112.3.7.

4. **Group I Occupancies.** Where patient rooms are added to an existing Group I Occupancy, a percentage of the additional rooms equal to the requirement of Section 1103.1.6, but in no case more than the total number of rooms required by Section 1103.1.6, shall comply with Section

1106.23. Where toilet or bathing facilities are part of the accessible rooms, they shall comply with Section 1106.11.

5. **Path of Travel.** Where an addition affects the access to or use of an area of primary function, to the maximum extent feasible, the path of travel to the area of primary function shall be made accessible.

EXCEPTION: Subject to the approval of the building official, the path of travel need not be made accessible if the cost of compliance with this part would exceed 20 percent of the total cost of construction, inclusive of the cost of eliminating barriers, within a 36-month period.

[Statutory Authority: RCW 19.27.031 and 19.27.074. 98-02-054, § 51-40-1111, filed 1/6/98, effective 7/1/98.]

WAC 51-40-1112 Section 1112—Alterations.**Section 1112 Alterations.****1112.1 General.**

1112.1.1 Compliance. Alterations to existing buildings or facilities shall comply with this section. No alteration shall reduce or have the effect of reducing accessibility or usability of a building, portion of a building, or facility. If compliance with this section is technically infeasible, the alteration shall provide accessibility to the maximum extent feasible.

EXCEPTION: Except when substantial as defined by Section 1110, alterations to Group R, Division 1 apartment buildings need not comply with this section.

1112.1.2 Existing elements. Where existing elements, spaces, essential features or common areas are altered, each such altered element, space, feature, or area shall comply with the applicable provisions of Part II of this chapter. Where an alteration is to an area of primary function, to the maximum extent feasible, the path of travel to the altered area shall be made accessible. See also Appendix Chapter 11 Division II.

EXCEPTIONS:

1. An accessible route of travel need not be provided to altered elements, spaces or common areas which are not areas of primary function.
2. Areas of evacuation assistance need not be added to an altered building.
3. Subject to the approval of the building official, the path of travel need not be made accessible if the cost of compliance with this part would exceed 20 percent of the total cost of construction, inclusive of the cost of eliminating barriers, within a 36-month period.

1112.1.3 Installation of stairs or escalators. Where an escalator or new stairway is planned or installed requiring major structural changes, then a means of vertical transportation (e.g. elevator, platform lift) shall be provided in accordance with this chapter.

1112.1.4 Other requirements.

1112.1.4.1 Where alterations of single elements, when considered together, amount to an alteration of a room or space in a building or facility, the entire area or space shall be accessible.

1112.1.4.2 No alteration of an existing element, space or area of a building shall impose a requirement for greater accessibility than that which would be required for new construction.

1112.1.4.3 Where the alteration work is limited solely to the electrical, mechanical or plumbing system or hazardous materials removal, and does not involve the alteration, structural or otherwise, of any elements and spaces required to be accessible under these standards, Chapter 11 does not apply.

1112.1.4.4 Where alterations would increase the number of public pay telephones to four, with at least one in the interior, or where the facility has four or more public pay telephones and one or more is altered; at least one interior text telephone shall be provided in accordance with Section 1106.14.

1112.1.4.5 Where a building has an accessible entrance, altered entrances need not be made accessible unless they provide access to areas of primary function.

1112.1.4.6 Where sleeping rooms are altered in an existing Group R, Division 1 hotel, at least 1 sleeping room that complies with Section 1106.26 shall be provided for each 25 sleeping rooms or fraction thereof. In addition, at least 1 sleeping room for each 25 sleeping rooms or fraction thereof shall have telephones, visible alarms, and visible notification devices in accordance with Section 1103.1.8.3.

1112.1.4.7 Where patient bedrooms are altered in an existing Group I Occupancy, a percentage of the altered bedrooms equal to the requirement of Section 1103.1.6, but in no case more than the total number of bedrooms required by Section 1103.1.6, shall comply with Section 1106.23. Where toilet or bathing facilities are part of the accessible rooms, they shall comply with Section 1106.11.

1112.2 Substantial Alterations. Where substantial alteration as defined in Section 1110 occurs to a building or facility, the entire building or facility shall comply with Part II of this code.

EXCEPTIONS:

1. Areas of evacuation assistance need not be added to a substantially altered building.
2. Type B Dwelling units need not be provided in buildings which are substantially altered.

1112.3 Modifications.

1112.3.1 General. The following modifications set forth in this section may be used for compliance where the required standard is technically infeasible or when providing access to historic buildings.

1112.3.2 Ramps. Curb ramps and ramps constructed on existing sites, or in existing buildings or facilities, may have slopes and rises greater than specified in Part II of this chapter, where space limitations preclude the use of 1 vertical in 12 horizontal slope or less, provided that:

1. A slope not greater than 1 vertical in 10 horizontal is allowed for a maximum rise of 6 inches (152 mm).
2. A slope not greater than 1 vertical in 8 horizontal is allowed for a maximum rise of 3 inches (76 mm).
3. Slopes greater than 1 vertical in 8 horizontal are prohibited.

1112.3.3 Stairways. Full extension of stair handrails is not required when such extension would be hazardous or impossible due to plan configuration. When an accessible elevator is provided, existing stairs need not be made accessible.

(2003 Ed.)

sible due to plan configuration. When an accessible elevator is provided, existing stairs need not be made accessible.

1112.3.4 Elevators. Elevators shall comply with Chapter 296-81, Washington Administrative Code.

1112.3.5 Platform lifts. Upon the approval of the building official, platform lifts may be used in alterations, in locations in addition to those permitted in Part II of this chapter, if installation of an elevator is technically infeasible.

Platform lifts shall comply with Chapter 296-81 of the Washington Administrative Code.

1112.3.6 Doors.

1112.3.6.1 Clearance. When existing elements prohibit strict compliance with the clearance requirements, a projection of 5/8 inch (16 mm) maximum is permitted for the latch side door stop.

1112.3.6.2 Thresholds. Existing thresholds measuring 3/4 inch (19 mm) high or less which are modified to provide a beveled edge on each side, may be retained.

1112.3.7 Toilet rooms.

1112.3.7.1 Shared facilities. The addition of one unisex toilet facility accessible to all occupants on the floor may be provided in lieu of making existing toilet facilities accessible when it is technically infeasible to comply with either part of Chapter 11. The unisex facility shall be located in the same area as existing facilities.

1112.3.7.2 Number. The number of toilet facilities and water closets required by the Building Code may be reduced by one, in order to provide accessible features.

1112.3.7.3 Signage. When existing toilet facilities are altered and not all are made accessible, directional signage complying with Section 1106.16.3 and 1106.16.4 shall be provided indicating the location of the nearest accessible toilet facility.

1112.3.8 Assembly areas. Seating shall adjoin an accessible route of travel that also serves as a means of emergency egress or route to an area for evacuation assistance. In alterations, accessibility to raised or sunken dining areas, or to all parts of outdoor seating areas is not required provided that the same services and amenities are provided in an accessible space usable by the general public and not restricted to use by people with disabilities.

1112.3.9 Dressing rooms. Where it is technically infeasible to meet the requirements of Part II of this chapter, one dressing room for each sex, or a unisex dressing room, on each level shall be accessible.

[Statutory Authority: RCW 19.27.031 and 19.27.074. 98-02-054, § 51-40-1112, filed 1/6/98, effective 7/1/98.]

WAC 51-40-1113 Section 1113—Historic preservation.

Section 1113.1 General. Generally the accessibility provisions of this part shall be applied to historic buildings and facilities as defined in Section 3403.5 of this code.

The building official, after consulting with the appropriate historic preservation officer, shall determine whether provisions required by this part for accessible routes of travel (interior or exterior), ramps, entrances, toilets, parking, or signage would threaten or destroy the historic significance of the building or facility.

If it is determined that any of the accessibility requirements listed above would threaten or destroy the historic significance of a building or facility, the modifications of Section 1112.3 for that feature may be utilized.

1113.2 Special Provisions. Where removing architectural barriers or providing accessibility would threaten or destroy the historic significance of a building or facility, the following special provisions may be used:

1. At least one accessible route from a site access point to an accessible route of travel shall be provided.
2. At least one accessible entrance which is used by the public shall be provided.

EXCEPTION: Where it is determined by the building official that no entrance used by the public can comply, access at any accessible entrance which is unlocked during business hours may be used provided directional signs are located at the primary entrance, and the accessible entrance has a notification system. The route of travel for the accessible entrance shall not pass through hazardous areas, storage rooms, closets, kitchens or spaces used for similar purposes.

3. Where toilet facilities are provided, at least one toilet facility complying with Section 1111 and 1112 shall be provided along an accessible route. Such toilet facility shall be a shared facility available to both sexes.

4. Accessible routes from an accessible entrance to all publicly used spaces, on at least the level of accessible entrance, shall be provided. Access should be provided to all levels of a building or facility when practical. Displays and written information and documents shall be located where they can be seen by a seated person.

[Statutory Authority: RCW 19.27.031 and 19.27.074. 98-02-054, § 51-40-1113, filed 1/6/98, effective 7/1/98.]

WAC 51-40-1114 Section 1114—Appeal.

Section 1114.1 Request for Appeal. An appeal from the standards for accessibility for existing buildings may be filed with the building official in accordance with Section 105, when existing structural elements or physical constraints of the site prevent full compliance or would threaten or destroy the historical significance of a historic building.

1114.2 Review.

1114.2.1 Consideration of alternative methods. Review of appeal requests shall include consideration of alternative methods which may provide partial access.

1114.2.2 Waiver or modification of requirements. The appeals board may waive or modify the requirements of this section when it is determined that compliance with accessibility requirements would threaten or destroy the historic significance of a building or facility.

[Statutory Authority: RCW 19.27.031 and 19.27.074. 98-02-054, § 51-40-1114, filed 1/6/98, effective 7/1/98.]

WAC 51-40-1191 Table No. 11-A.

**TABLE NO. 11-A
WHEELCHAIR SPACES REQUIRED IN ASSEMBLY AREAS**

Capacity of Seating in Assembly Area	Number of Required Wheelchair Spaces
4 to 25	1
26 to 50	2
51 to 300	4
301 to 500	6
over 500	6 plus 1 for each 100 over 500

[Statutory Authority: RCW 19.27.031 and 19.27.074. 98-02-054, § 51-40-1191, filed 1/6/98, effective 7/1/98.]

WAC 51-40-1192 Table No. 11-B.

**TABLE NO. 11-B
REQUIRED TYPE A DWELLING UNITS**

Total Number of Dwelling Units on Site	Required Number of Type A Dwelling Units
0 - 10	None
11 - 20	1
21 - 40	2
41 - 60	3
61 - 80	4
81 - 100	5
for every 20 units or fractional part thereof, over 100	1 additional

[Statutory Authority: RCW 19.27.031 and 19.27.074. 98-02-054, § 51-40-1192, filed 1/6/98, effective 7/1/98.]

WAC 51-40-1193 Table No. 11-C.

**TABLE NO. 11-C
NUMBER OF ACCESSIBLE ROOMS AND ROLL-IN SHOWERS**

Total Number Of Rooms ¹	Minimum Required Accessible Rooms ¹	Rooms With Roll-In Showers
1 - 25	1	None
26 - 50	2	None

51 - 75	3	1
76 - 100	4	1
101 - 150	5	2
151 - 200	6	2
201 - 300	7	3
301 - 400	8	4
401 - 500	9	4 plus 1 for every 100 rooms or fraction thereof, over 400
501 - 1000	2% of total rooms	
Over 1000	20 plus 1 for every 100 rooms or fraction thereof, over 1000	

¹ For congregate residences the numbers in these columns shall apply to beds rather than rooms.

[Statutory Authority: RCW 19.27.031 and 19.27.074. 98-02-054, § 51-40-1193, filed 1/6/98, effective 7/1/98.]

WAC 51-40-1194 Table No. 11-D.

**TABLE NO. 11-D
NUMBER OF ACCESSIBLE ROOMS FOR PERSONS
WITH HEARING IMPAIRMENTS**

Total Number Of Rooms	Minimum Required Rooms
1 - 25	1
26 - 50	2
51 - 75	3
76 - 100	4
101 - 150	5
151 - 200	6
201 - 300	7
301 - 400	8
401 - 500	9
501 - 1000	2% of total rooms
Over 1000	20 plus 1 for every 100 rooms, or fraction thereof, over 1000

[Statutory Authority: RCW 19.27.031 and 19.27.074. 98-02-054, § 51-40-1194, filed 1/6/98, effective 7/1/98.]

WAC 51-40-1195 Table No. 11-E.

**TABLE NO. 11-E
REQUIRED CHECK-OUT AISLES**

Total Check-out Aisles Units on Site	Minimum Number of Accessible Check-out Aisles
1 - 4	1
5 - 8	2
9 - 15	3
Over 15	3 plus 20% of additional aisles

[Statutory Authority: RCW 19.27.031 and 19.27.074. 98-02-054, § 51-40-1195, filed 1/6/98, effective 7/1/98.]

WAC 51-40-1196 Table No. 11-F.

**TABLE NO. 11-F
NUMBER OF ACCESSIBLE PARKING SPACES**

Total Parking Spaces in Lot or Garage	Minimum Required Number of Accessible Spaces
1 - 25	1
26 - 50	2
51 - 75	3
76 - 100	4
101 - 150	5
151 - 200	6
201 - 300	7
301 - 400	8
401 - 500	9
501 - 1000	2% of total spaces
Over 1000	20 spaces plus 1 space for every 100 spaces, or fraction thereof, over 1000

[Statutory Authority: RCW 19.27.031 and 19.27.074. 98-02-054, § 51-40-1196, filed 1/6/98, effective 7/1/98.]

WAC 51-40-1202 Section 1202—Light and ventilation in Groups A, B, E, F, H, I, M and S Occupancies.

1202.2 Ventilation.

1202.2.1 General. All enclosed portions of Groups A, B, E, F, H, I, M and S Occupancies customarily occupied by human beings shall be provided with natural ventilation by means of openable exterior openings with an area not less than 1/20 of the total floor area or shall be provided with a mechanically operated ventilation system which complies with Ventilation and Indoor Air Quality Code Section 304. Such exterior openings shall open directly onto a public way or a yard or court as set forth in Section 1203.4.

Toilet rooms shall be provided with a fully openable exterior window with an area not less than 3 square feet (0.279 m²), or a vertical duct not less than 100 square inches (64 516 mm²) in area for the first water closet plus 50 square inches (32 258 mm²) additional of area for each additional water closet, or a mechanically operated exhaust system which complies with Ventilation and Indoor Air Quality Code Section 304. Such mechanically operated exhaust systems shall be connected directly to the outside, and the point of discharge shall be at least 3 feet (914 mm) from any opening that allows air entry into occupied portions of the building.

For ventilation of hazardous vapors or fumes in Group H Occupancies, see Sections 307.5.2 and 1202.2.3. For Group S, Division 3 Occupancies, see Section 1202.2.7.

1202.2.4 Group H, Division 4 Occupancies. In all buildings classified as Group H, Division 4 Occupancies used for the repair or handling of motor vehicles operating under their own power, mechanical ventilation shall be provided capable of exhausting a minimum of 1.5 cubic feet per minute per

square foot (0.044 L/s/m²) of floor area. Each engine repair stall shall be equipped with an exhaust pipe extension duct, extending to the outside of the building, which, if over 10 feet (3048 mm) in length, shall mechanically exhaust 300 cubic feet per minute (141.6 L/s). Connecting offices and waiting rooms shall be supplied with conditioned air under positive pressure.

EXCEPTION: When approved, ventilating equipment may be omitted in repair garages, enclosed heliports and aircraft hangars when well-distributed unobstructed openings to the outer air of sufficient size to supply necessary ventilation are furnished.

1202.2.7 Group S parking garages. In Group S, Division 3 parking garages, other than open parking garages, used for storing or handling automobiles operating under their own power and on loading platforms in bus terminals, ventilation shall be provided which complies with Ventilation and Indoor Air Quality Code Section 304. The building official may approve an alternate ventilation system designed to exhaust a minimum of 14,000 cfm (6608 L/s) for each operating vehicle. Such system shall be based on the anticipated instantaneous movement rate of vehicles, but not less than 2.5 percent (or one vehicle) of the garage capacity. Automatic carbon monoxide-sensing devices may be employed to modulate the ventilation system to maintain a maximum average concentration of carbon monoxide of 50 parts per million during any eight-hour period, with a maximum concentration not greater than 200 parts per million for a period not exceeding one hour. Connecting offices, waiting rooms, ticket booths and similar uses shall be supplied with conditioned air under positive pressure.

EXCEPTION: Mechanical ventilation need not be provided within a Group S, Division 3 parking garage when openings complying with Section 311.9.2.2 are provided.

[Statutory Authority: RCW 19.27.031, 19.27.074, 01-02-095, § 51-40-1202, filed 1/3/01, effective 7/1/01.]

WAC 51-40-1203 Section 1203—Light and ventilation in Group R Occupancies.

1203.3 Ventilation. Group R Occupancies shall be provided with ventilation systems which comply with Ventilation and Indoor Air Quality Code Section 302 and 303. Public corridors in Group R Occupancies shall be provided with natural ventilation by means of openable exterior openings with an area of not less than one twentieth of the floor area of such corridors with a minimum of 5 square feet (0.46 m²).

In lieu of required exterior openings for natural ventilation in public corridors, a mechanical ventilating system may be provided. Such system shall be capable of providing two air changes per hour with a minimum of 15 cubic feet per minute (7 L/s) of outside air per occupant during such time as the building is occupied.

The point of discharge for mechanical ventilating systems shall be at least 3 feet (914 mm) from any opening which allows air entry into occupied portions of the building.

[Statutory Authority: RCW 19.27.031, 19.27.074, 01-02-095, § 51-40-1203, filed 1/3/01, effective 7/1/01; 98-02-054, § 51-40-1203, filed 1/6/98, effective 7/1/98.]

[Title 51 WAC—p. 178]

WAC 51-40-1616 Section 1616—Definitions.

EXPOSURE D represents the most severe exposure in areas with basic wind speeds greater than 80 miles per hour (mph) (129 km/h) and has terrain which is flat and unobstructed facing large bodies of water over one mile (1.61 km) or more in width relative to any quadrant of the building site. Exposure D extends inland from the shoreline 1/4 mile (0.40 km) or 10 times the building height, whichever is greater.

[Statutory Authority: RCW 19.27.031 and 19.27.074, 98-02-054, § 51-40-1616, filed 1/6/98, effective 7/1/98.]

WAC 51-40-1702 Section 1702—Structural observation.

Structural observation shall be provided in Seismic Zone 3 or 4 when one of the following conditions exists:

1. The structure is defined in Table 16-K as Occupancy Category I, II or III,
2. The structure is required to comply with Section 403,
3. The structure is in Seismic Zone 4, N_s as set forth in Table 16-S is greater than one, and a lateral design is required for the entire structure,

EXCEPTION: One- and two-story Group R, Division 3 and Group U Occupancies and one- and two-story Groups B, F, M and S Occupancies.

4. When so designated by the architect or engineer of record, or
5. When such observation is specifically required by the building official for unusual lateral force-resisting structures or irregular structures as defined in Section 1629.

The owner shall employ the engineer or architect responsible for the structural design, or another engineer or architect designated by the engineer or architect responsible for the structural design, to perform structural observations as defined in Section 220. Observed deficiencies shall be reported in writing to the owner's representative, special inspector, contractor and the building official. The structural observer shall submit to the building official a written statement that the site visits have been made and identifying any reported deficiencies that, to the best of the structural observer's knowledge, have not been resolved.

[Statutory Authority: RCW 19.27.031 and 19.27.074, 98-02-054, § 51-40-1702, filed 1/6/98, effective 7/1/98.]

WAC 51-40-1909 Section 1909—Strength and serviceability requirements.

1909.3.4 In *Seismic Zones 3 and 4*, strength-reduction factors ϕ shall be as given above except for the following:

1909.3.4.1 *The shear strength-reduction factor shall be 0.6 for the design of walls, topping slabs used as diaphragms over precast concrete members and structural framing members, with the exception of joints, if their nominal shear strength is less than the shear corresponding to development of their nominal flexural strength. The nominal flexural strength shall be determined corresponding to the most criti-*

(2003 Ed.)

cal factored axial loads including earthquake effects. The shear strength-reduction factor for joints shall be 0.85.

1909.3.4.2 is not adopted.

[Statutory Authority: RCW 19.27.031 and 19.27.074. 98-02-054, § 51-40-1909, filed 1/6/98, effective 7/1/98.]

WAC 51-40-2406 Section 2406—Safety glazing.

2406.4 Hazardous Locations. The following shall be considered specific hazardous locations for the purposes of glazing:

1. Glazing in ingress and egress doors except jalousies.
2. Glazing in fixed and sliding panels of sliding door assemblies and panels in swinging doors other than wardrobe doors.
3. Glazing in storm doors.
4. Glazing in all unframed swinging doors.
5. Glazing in doors and enclosures for hot tubs, whirlpools, saunas, steam rooms, bathtubs and showers. Glazing in any portion of a building wall enclosing these compartments where the bottom exposed edge of the glazing is less than 60 inches (1525 mm) above a standing surface and drain inlet.

6. Glazing in fixed or operable panels adjacent to a door where the nearest exposed edge of the glazing is within a 24-inch (610 mm) arc of either vertical edge of the door in a closed position and where the bottom exposed edge of the glazing is less than 60 inches (1525 mm) above the walking surface.

7. Glazing in an individual fixed or operable panel, other than those locations described in Items 5 and 6, that meets all of the following conditions:

7.1 Exposed area of an individual pane greater than 9 square feet (0.84 m²).

7.2 Exposed bottom edge less than 18 inches (457 mm) above the floor.

7.3 Exposed top edge greater than 36 inches (914 mm) above the floor.

7.4 One or more walking surfaces within 36 inches (914 mm) horizontally of the plane of the glazing.

8. Glazing in railings regardless of height above a walking surface. Included are structural baluster panels and non-structural in-fill panels.

EXCEPTION: The following products and applications are exempt from the requirements for hazardous locations as listed in Items 1 through 8:

1. Glazing in Item 6 when there is an intervening wall or other permanent barrier between the door and the glazing.
2. Glazing in Item 7 when a protective bar is installed on the accessible sides of the glazing 34 inches (864 mm) to 38 inches (965 mm) above the floor. The bar shall be capable of withstanding a horizontal load of 50 pounds per linear foot (729 N/m) without contacting the glass and be a minimum of 1 1/2 inches (38 mm) in height.
3. Outboard pane in insulating glass units and in other multiple glazed panels in Item 7 when the bottom

exposed edge of the glass is 25 feet (7620 mm) or more above any grade, roof, walking surface, or other horizontal or sloped (within 45 degrees of horizontal) surface adjacent to the glass exterior.

4. Openings in door through which a 3-inch-diameter (76.2 mm) sphere will not pass.

5. Assemblies of leaded, faceted or carved glass in Items 1, 2, 6 and 7 when used for decorative purposes.

6. Curved panels in revolving door assemblies.

7. Doors in commercial refrigerated cabinets.

8. Glass block panels complying with Section 2110.

9. Glazing in walls and fences used as the barrier for indoor and outdoor swimming pools and spas when all of the following conditions are present:

9.1 The bottom edge of the glazing is less than 60 inches (1525 mm) above the pool side of the glazing.

9.2 The glazing is within 5 feet (1525 mm) of a swimming pool or spa water's edge.

10. Glazing in walls at stairway landings within the width of the stair and within 5 feet (1525 mm) beyond the bottom and top of flights of stairs, where the bottom edge of the glazing is less than 60 inches (1525 mm) above a walking surface.

[Statutory Authority: RCW 19.27.031 and 19.27.074. 98-02-054, § 51-40-2406, filed 1/6/98, effective 7/1/98.]

WAC 51-40-2900 Chapter 29—Plumbing systems.

SECTION 2901—PLUMBING CODE.

Plumbing systems shall comply with the Plumbing Code.

SECTION 2902—GENERAL

2902.1 Number of Fixtures.

2902.1.1 Requirements. Plumbing fixtures shall be provided in the minimum number shown in Table 29-A and in this Chapter. Where the proposed occupancy is not listed in Table 29-A, the building official shall determine fixture requirements based on the occupancy which most nearly resembles the intended occupancy.

Plumbing fixtures need not be provided for unoccupied buildings or facilities.

2902.1.2 Private offices. Fixtures only accessible to private offices shall not be counted to determine compliance with this section.

2902.1.3 Occupancy load distribution. The occupant load shall be divided equally between the sexes, unless data approved by the building official indicates a different distribution of the sexes.

2902.1.4 Food preparation areas. In food preparation, serving and related storage areas, additional fixture requirements may be dictated by health codes.

2902.1.5 Other requirements. For other requirements for plumbing facilities, see Sections 302.6, 807, 313.5.5 and Chapter 11.

2902.2 Access to Fixtures.

2902.2.1 Location. Plumbing fixtures shall be located in each building or conveniently in a building adjacent thereto on the same property.

2902.2.2 Multiple tenants. Access to toilets serving multiple tenants shall be through a common use area and not through an area controlled by a tenant.

2902.2.3 Multi-story buildings. Required fixtures shall not be located more than one vertical story above or below the area served.

2902.3 Separate Facilities.

2902.3.1 Requirements. Separate toilet facilities shall be provided for each sex.

EXCEPTIONS:

1. In occupancies serving 10 or fewer persons, one toilet facility designed for use by no more than one person at a time shall be permitted for use by both sexes.
2. In Group B and M Occupancies with a total floor area of 1500 square feet (139.5 m²) or less, one toilet facility designed for use by no more than one person at a time shall be permitted for use by both sexes.

2902.3.2 Food service establishments. When customers and employees share the same facilities, customers accessing the facilities are excluded from food preparation and storage areas.

2902.4 Pay Facilities. Required facilities shall be free of charge. Where pay facilities are installed, they shall be in addition to the minimum required facilities.

2902.5 is not adopted.

2902.6 is not adopted.

SECTION 2903—SPECIAL PROVISIONS

WAC 51-40-2929 Table 29-A—Minimum plumbing fixtures.

TABLE 29-A — MINIMUM PLUMBING FIXTURES ^{1,2,4,6}

TYPE OF BUILDING OR OCCUPANCY	WATER CLOSETS (fixtures per person)		LAVATORIES ⁵ (fixtures per person)		BATHTUB OR SHOWER (fixtures per person)
	MALE ³	FEMALE	MALE	FEMALE	
For the occupancies listed below, use 30 square feet (2.79 m ²) per occupant for the minimum number of plumbing fixtures:					
Group A Conference rooms, dining rooms, drinking establishments, exhibit rooms, gymnasiums, lounges, stages and similar uses including restaurants classified as Group B Occupancies	1:1-25 2:26-75 3:76-125 4:126-200 5:201-300 6:301-400 Over 400, add one fixture for each additional 200 males or 150 females.	1:1-25 2:26-75 3:76-125 4:126-200 5:201-300 6:301-400	one per 2 water closets		
For the assembly occupancies listed below, use the number of fixed seating or, where no fixed seating is provided, use 15 square feet (1.39 m ²) per occupant for the minimum number of plumbing fixtures.					
Assembly places — Theaters, auditoriums, convention halls, dance floors, lodge rooms, casinos, and such places which have limited time for fixture use (intermissions)	1:1-100 2:101-200 3:201-400 Over 400, add one fixture for each additional 250 males or 50 females.	One per 25 up to 400	1:1-200 2:201-400 3:401-750 Over 750, add one fixture for each additional 500 persons.	1:1-200 2:201-400 3:401-750	

2903.1 Dwelling Units. Dwelling units shall be provided with a kitchen sink.

2903.2 Water Closet Space Requirements. The water closet stool in all occupancies shall be located in a clear space not less than 30 inches (762 mm) in width, with a clear space in front of the stool of not less than 24 inches (610 mm).

2903.3 Water. Each required sink, lavatory, bathtub and shower stall shall be equipped with hot and cold running water necessary for its normal operation.

2903.4 Drinking Fountains.

2903.4.1 Number. Occupant loads over 30 shall have one drinking fountain for the first 150 occupants, then one per each additional 500 occupants.

EXCEPTIONS:

1. Sporting facilities with concessions serving drinks shall have one drinking fountain for each 1000 occupants.
2. A drinking fountain need not be provided in a drinking or dining establishment.

2904.2 Multi-story buildings. Drinking fountains shall be provided on each floor having more than 30 occupants in schools, dormitories, auditoriums, theaters, offices and public buildings.

2903.4.3 Penal Institutions. Penal institutions shall have one drinking fountain on each cell block floor and one on each exercise floor.

2903.4.4 Location. Drinking fountains shall not be located in toilet rooms.

SECTION 2904 is not adopted.

[Statutory Authority: RCW 19.27.031, 19.27.074, 01-02-095, § 51-40-2900, filed 1/3/01, effective 7/1/01; 98-02-054, § 51-40-2900, filed 1/6/98, effective 7/1/98.]

TYPE OF BUILDING OR OCCUPANCY	WATER CLOSETS (fixtures per person)		LAVATORIES ⁵ (fixtures per person)		BATHTUB OR SHOWER (fixtures per person)
	MALE ³	FEMALE	MALE	FEMALE	
Group A Assembly places — Stadiums, arena and other sporting facilities where fix- ture use is not limited to inter- missions.	1:1-100 2:201-200 3:201-400 Over 400, add one fixture for each additional 300 males or 100 females.	One per 50 up to 400	1:1-200 2:201-400 3:401-750 Over 750, add one fixture for each additional 500 persons.	1:1-200 2:201-400 3:401-750	
For the assembly occupancies listed below, use the number of fixed seating or, where no fixed seating is provided, use 30 square feet (2.79 m ²) per occupant for the minimum number of plumbing fixtures.					
Worship places Principal assembly area Worship places Educational and activity unit	one per 150 one per 75 one per 125 one per 75	one per 75	one per 2 water closets one per 2 water closets		
For the occupancies listed below, use 200 square feet (18.58 m ²) per occupant for the minimum number of plumbing fixtures					
Group B and other clerical or adminis- trative employee accessory use	1:1-15 2:16-35 3:36-55 Over 55, add one for each additional 50 persons.	1:1-15 2:16-35 3:36-55	one per 2 water closets		
For the occupancies listed below, use 100 square feet (9.3 m ²) per student for the minimum number of plumbing fixtures.					
Group E Schools — for staff use All schools (One staff per 20 students) Schools — for student use Day care Elementary Secondary	1:1-15 2:16-35 3:36-55 Over 55, add one fixture for each additional 40 persons. 1:1-20 2:21-50 Over 50, add one fixture for each additional 50 persons. one per 30 one per 40	1:1-15 2:16-35 3:36-55 1:1-20 2:21-50 one per 25 one per 30	one per two water closets one per two water closets one per two water closets one per two water closets	1:1-20 2:21-50 1:1-20 2:21-50 one per two water closets one per two water closets	
For the occupancies listed below, use 50 square feet (4.65 m ²) per occupant for the minimum number of plumbing fixtures.					
Education Facilities other than Group E Others (colleges, universities, adult centers, etc.)	one per 40	one per 25	one per two water closets		
For the occupancies listed below, use 2,000 square feet (185.8 m ²) per occupant for the minimum number of plumbing fixtures.					
Group F and Group H Workshop, foundries and sim- ilar establishments, and haz- ardous occupancies	1:1-10 2:11-25 3:26-50 4:51-75 5:76-100 Over 100, add one fixture for each additional 30 persons.	1:1-10 2:11-25 3:26-50 4:51-75 5:76-100	one per two water closets		one shower for each 15 per- sons exposed to excessive heat or to skin contamination with irritating materials
For the occupancies listed below, use the designated application and 200 square feet (18.58 m ²) per occupant of the general use area for the minimum number of plumbing fixtures.					
Group I ⁷ Hospital waiting rooms Hospital general use areas	one per room (usable by either sex) 1:1-15 2:16-35 3:36-55 Over 55, add one fixture for each additional 40 persons.	1:1-15 3:16-35 4:36-55	one per room one per two water closets		

TYPE OF BUILDING OR OCCUPANCY	WATER CLOSETS (fixtures per person)		LAVATORIES ⁵ (fixtures per person)		BATHTUB OR SHOWER (fixtures per person)
	MALE ³	FEMALE	MALE	FEMALE	
Hospital patient rooms: Single Bed	one adjacent to and directly accessible from		one per toilet room		one per toilet room
Isolation	one adjacent to and directly accessible from		one per toilet room		one per toilet room
Multi-Bed	one per four patients		one per four patients		one per eight patients
Long-term	one per four patients		one per four patients		one per 15 patients
Jails and reformatories Cell	one per cell		one per cell		
Exercise room	one per exercise room		one per exercise room		
Other institutions (on each occupied floor)	one per 25	one per 25	one per two water closets		one per eight
Group LC For Group LC Occupancies, the minimum number of plumbing fixtures is specified in Section 313.5.5.					
For the occupancies listed below, use 200 square feet (18.58 m ²) per occupant for the minimum number of plumbing fixtures.					
Group M Retail or wholesale stores	1:1-50 2:51-100 3:101-400	1:1-50 2:51-100 3:101-200 4:201-300 5:301-400	one per two water closets		
	Over 400, add one fixture for each additional 300 males or 150 females.				
For Group R Occupancies, dwelling units and hotel guest rooms, use the table below. For congregate residences, use 200 square feet (18.58 m ²) per occupant for Group R, Division 1 Occupancies and 300 square feet (27.87 m ²) per occupant for Group R, Division 3 Occupancies for the minimum number of plumbing fixtures.					
Group R Dwelling units Hotel guest rooms Congregate residences	one per dwelling unit one per guest room one per 10	one per 8 Over 10, add one fixture for each additional 25 males and over 8, add one for each additional 20 females.	one per dwelling unit one per guest room one per 12	one per 12	one per dwelling unit one per guest room one per eight For females, add one additional unit per each additional 30. Over 150 persons, add one additional unit per each additional 20 persons.
For the occupancies listed below, use 5,000 square feet (464.5 m ²) per occupant for the minimum number of plumbing fixtures.					
Group S Warehouses	1:10-10 2:11-25 3:26-50 4:51-75 5:76-100	1:10-10 2:11-25 3:26-50 4:51-75 5:76-100	One per 40 occupants of each sex.		one shower for each 15 persons exposed to excessive heat or to skin contamination with poisonous, infectious or irritating materials.
	Over 100, add one for each 30 persons.				

¹ The figures shown are based on one fixture being the minimum required for the number of persons indicated or any fraction thereof.

² For occupancies not shown, see Section 2902.1.1.

³ Where urinals are provided, one water closet less than the number specified may be provided for each urinal installed, except the number of water closets in such cases shall not be reduced to less than one quarter (25%) of the minimum specified. For men's facilities serving 26 or more persons, not less than one urinal shall be provided.

⁴ For drinking fountains, see Section 2903.4.

⁵ Twenty-four inches (610 mm) of wash sink or 18 inches (457 mm) of a circular basin, when provided with water outlets for such space, shall be considered equivalent to one lavatory.

⁶ For when a facility may be usable by either sex, see Section 2902.3.1.

⁷ See WAC 246-318-690 for definitions, other fixtures and equipment for hospitals.

[Statutory Authority: RCW 19.27.031 and 19.27.074. 98-02-054, § 51-40-2929, filed 1/6/98, effective 7/1/98.]

WAC 51-40-3004 Hoistway venting.

SECTION 3004—Hoistway Venting.

Shafts (hoistways) housing elevators extending through more than two floor levels shall be vented to the outside. The area of the vent shall not be less than 3 1/2 percent of the area of the elevator shaft, provided a minimum of 3 square feet (0.279 m²) per elevator is provided. Vents shall be capable only of manual operation or controlled by a manual switch mounted in an approved location.

The venting of each individual hoistway shall be independent from any other hoistway venting, and the intercon-

nection of separate hoistways for the purpose of venting is prohibited.

[Statutory Authority: RCW 19.27.031 and 19.27.074, 98-02-054, § 51-40-3004, filed 1/6/98, effective 7/1/98.]

WAC 51-40-3102 Section 3102—Chimneys, fireplaces and barbecues.

3102.5.4 Emission Standards for Factory-built Fireplaces. After January 1, 1997, no new or used factory-built fireplace shall be installed in Washington State unless it is certified and labeled in accordance with procedures and criteria specified in the Washington State Building Code Standard 31-2.

To certify an entire fireplace model line, the internal assembly shall be tested to determine its particulate matter emission performance. Retesting and recertifying is required if the design and construction specifications of the fireplace model line internal assembly change. Testing for certification shall be performed by a Washington State Department of Ecology (DOE) approved and U.S. Environmental Protection Agency (EPA) accredited laboratory.

3102.7.14 Emission Standards for Certified Masonry and Concrete Fireplaces. After January 1, 1997, new certified masonry or concrete fireplaces installed in Washington State shall be tested and labeled in accordance with procedures and criteria specified in the Washington State Building Code Standard 31-2.

To certify an entire fireplace model line, the internal assembly shall be tested to determine its particulate matter emission performance. Retesting and recertifying is required if the design and construction specifications of the fireplace model line internal assembly change. Testing for certification shall be performed by a Washington State Department of Ecology (DOE) approved and U.S. Environmental Protection Agency (EPA) accredited laboratory.

[Statutory Authority: RCW 19.27.031, 19.27.074, 01-02-095, § 51-40-3102, filed 1/3/01, effective 7/1/01; 98-02-054, § 51-40-3102, filed 1/6/98, effective 7/1/98.]

WAC 51-40-31200 Section 31-2—Standard test method for particulate emissions from fireplaces.

**WASHINGTON STATE BUILDING CODE STANDARD 31-2
STANDARD TEST METHOD FOR PARTICULATE EMISSIONS
FROM FIREPLACES**

See Sections 3102.5.4 and 3102.7.14, *Uniform Building Code*

SECTION 31.200—TITLE and SCOPE.

SECTION 31.200.1—TITLE.

This Appendix Chapter 31-2 shall be known as the "Washington State Standard Test Method for Particulate Emissions from Fireplaces" and may be cited as such; and will be referred to herein as "this Standard."

(2003 Ed.)

SECTION 31.200.2—SCOPE.

This Standard covers emissions performance, approval/certification procedures, test laboratory accreditation, record keeping, reporting requirements, and the test protocol for measuring particulate emissions from fireplaces.

All testing, reporting and inspection requirements of this Standard shall be conducted by a Washington State Department of Ecology (DOE) approved testing laboratory. In order to qualify for DOE approval, the test laboratory must be a U.S. Environmental Protection Agency (EPA) accredited laboratory (40 CFR Part 60, Subpart AAA). DOE may approve a test laboratory upon submittal of the following information:

1. A copy of their U.S. EPA accreditation certificate; and
2. A description of their facilities, test equipment, and test-personnel qualifications including education and work experience.

DOE may revoke a test laboratory approval when the test laboratory is no longer accredited by the U.S. EPA or if DOE determines that the test laboratory does not adhere to the testing requirements of this Chapter.

SECTION 31.201—DEFINITIONS. For the purpose of this Standard certain terms are defined as follows:

ANALYZER CALIBRATION ERROR is the difference between the gas concentration exhibited by the gas analyzer and the known concentration of the calibration gas when the calibration gas is introduced directly to the analyzer.

BURN RATE is the average rate at which test-fuel is consumed in a fireplace measured in kilograms of wood (dry basis) per hour (kg/hr) during a test-burn.

CALIBRATION DRIFT is the difference in the analyzer reading from the initial calibration response at a mid-range calibration value after a stated period of operation during which no unscheduled maintenance, repair, or adjustment took place.

CALIBRATION GAS is a known concentration of Carbon Dioxide (CO₂), Carbon Monoxide (CO), or Oxygen (O₂) in Nitrogen (N₂).

CERTIFICATION or AUDIT TEST is the completion of at least one, three-fuel-load test-burn cycle in accordance with Section 31.202.

FIREBOX is the chamber in the fireplace in which a test-fuel charge(s) is placed and combusted.

FIREPLACE is a wood burning device which is exempt from U.S. EPA 40 CFR Part 60, Subpart AAA and:

1. Is not a cookstove, boiler, furnace, or pellet stove as defined in 40 CFR Part 60, Subpart AAA, and
2. Is not a masonry heater as defined in Section 31.201, and
3. See Section 3102, Uniform Building Code for definitions of masonry and factory-built fireplaces as used in this Standard.

FIREPLACE DESIGN is the construction and/or fabrication specifications including all dimensions and materials required for manufacturing or building fireplaces with identical combustion function and particulate emissions factors.

FIREPLACE MODEL LINE is a series of fireplace models which all have the same internal assembly. Each model in a model line may have different facade designs and external decorative features.

FIREPLACE, CERTIFIED, is a fireplace that meets the emission performance standards when tested according to UBC Standard 31-2.

FIREPLACE, NONCERTIFIED, (masonry or concrete) is any fireplace that is not a certified fireplace. A noncertified fireplace will be subject to applicable burn ban restrictions.

INTERNAL ASSEMBLY is the core construction and firebox design which produces the same function and emissions factor for a fireplace model line.

MASONRY HEATER is a heating system of predominantly masonry construction having a mass of at least 800 kg (1760 lbs), excluding the chimney and foundation, which is designed to absorb a substantial portion of the heat energy from a rapidly-burned charge of solid fuel by:

a) Routing of exhaust gases through internal heat exchange channels in which the flow path downstream of the firebox includes at least one 180 degree change in flow direction, usually downward, before entering the chimney, and

b) Being constructed of sufficient mass such that under normal operating conditions the external surface of the heater, except in the region immediately surrounding the fuel loading door(s), does not exceed 110°C (230°F).

Masonry heaters shall be listed or installed in accordance with ASTM E-1602.

RESPONSE TIME is the amount of time required for the measurement system to display 95 percent of a step change in gas concentration.

SAMPLING SYSTEM BIAS is the difference between the gas concentrations exhibited by the analyzer when a known concentration gas is introduced at the outlet of the sampling probe and when the sample gas is introduced directly to the analyzer.

SPAN is the upper limit of the gas concentration measurement range (25 percent for CO₂, O₂, and 5 percent for CO).

TEST FACILITY is the area in which the fireplace is installed, operated, and sampled for emissions.

TEST FUEL LOADING DENSITY is the weight of the as-fired test-fuel charge per unit area of usable firebox floor (or hearth).

TEST-BURN is an individual emission test which encompasses the time required to consume the mass of three consecutively burned test-fuel charges.

TEST-FUEL CHARGE is the collection of test fuel pieces placed in the fireplace at the start of certification test.

USABLE FIREBOX AREA is the floor (or hearth) area, within the fire chamber of a fireplace upon which a fire may be, or is intended to be built. Usable firebox area is calculated using the following definitions:

1. Length. The longest horizontal fire chamber dimension along the floor of the firebox that is parallel to a wall of the fire chamber.

2. Width. The shortest horizontal fire chamber dimension along the floor of the firebox that is parallel to a wall of the fire chamber.

3. For angled or curved firebox walls and/or sides, the effective usable firebox area shall be determined by calculating the sum of standard geometric areas or sub-areas of the firebox floor.

If a fireplace has a floor area within the fire chamber which is larger than the area upon which it is intended that fuel be placed and burned, the usable firebox area shall be calculated as the sum of standard geometric areas or sub-areas of the area intended for fuel placement and burning. For fireplace grates which elevate the fuel above the firebox floor, usable firebox area determined in this manner shall be multiplied by a factor of 1.5. The weight of test-fuel charges for fireplace-grate usable-firebox-area tests, shall not exceed the weight of test-fuel charges determined for the entire fireplace floor area.

ZERO DRIFT is the difference in the analyzer reading from the initial calibration response at the zero concentration level after a stated period of operation during which no unscheduled maintenance, repair, or adjustment took place.

Section 31.202—Testing.

31.202.1 Applicability. This method is applicable for the certification and auditing of fireplace particulate emission factors. This method describes the test facility, fireplace installation requirements, test-fuel charges, and fireplace operation as well as procedures for determining burn rates and particulate emission factors.

31.202.2 Principle. Particulate matter emissions are measured from a fireplace burning prepared test-fuel charges in a test facility maintained at a set of prescribed conditions.

31.202.3 Test Apparatus.

31.202.3.1 Fireplace Temperature Monitors. Device(s) capable of measuring flue-gas temperature to within 1.5 percent of expected absolute temperatures.

31.202.3.2 Test Facility Temperature Monitor. A thermocouple located centrally in a vertically oriented pipe shield 6 inches (150 mm) long, 2 inches (50 mm) diameter that is open at both ends, capable of measuring air temperature to within 1.5 percent of expected absolute temperatures.

31.202.3.3 Balance. Balance capable of weighing the test-fuel charge(s) to within 0.1 lb (0.05 kg).

31.202.3.4 Moisture Meter. Calibrated electrical resistance meter for measuring test-fuel moisture to within 1 percent moisture content (dry basis).

31.202.3.5 Anemometer. Device capable of detecting air velocities less than 20 ft/min (0.10 m/sec), for measuring air velocities near the fireplace being tested.

31.202.3.6 Barometer. Mercury, aneroid or other barometer capable of measuring atmospheric pressure to within 0.1 inch Hg (2.5 mm Hg).

31.202.3.7 Draft Gauge. Electromanometer or other device for the determination of flue draft (i.e., static pressure) readable to within 0.002 inches of water column (0.50 Pa).

31.202.3.8 Combustion Gas Analyzer. Combustion gas analyzers for measuring Carbon Dioxide (CO₂), Carbon Monoxide (CO), and Oxygen (O₂) in the fireplace exhaust-gas stream must meet all of the following measurement system performance specifications:

1. **Analyzer Calibration Error.** Shall be less than ± 2 percent of the span value for the zero, mid-range, and high-range calibration gases.

2. **Sampling System Bias.** Shall be less than ± 5 percent of the span value for the zero, mid-range, and high-range calibration gases.

3. **Zero Drift.** Shall be less than ± 3 percent of the span over the period of each run.

4. **Calibration Drift.** Shall be less than ± 3 percent of the span value over the period of each run.

5. **Response Time.** Shall be less than 1.5 minutes.

31.202.4 Emissions Sampling Method. Use the emission sampler system (ESS) as described in Section 31.203.12 or an equivalent method as determined by the application of the U.S. EPA Method 301 Validation Procedure (Federal Register, December 12, 1992, Volume 57, Number 250, page 11998) and upon approval of DOE.

31.202.5 Fireplace Installation and Test Facility Requirements. The fireplace being tested must be constructed, if site-built, or installed, if manufactured, in accordance with the designer's/manufacture's written instructions. The chimney shall have a total vertical height above the base of the fire chamber of not less than 15 feet (4 600 mm). The fireplace chimney exit to the atmosphere must be freely communicating with the fireplace combustion makeup-air source. There shall be no artificial atmospheric pressure differential imposed between the chimney exit to the atmosphere and the fireplace makeup-air inlet.

31.202.6 Fireplace Aging and Curing. A fireplace of any type shall be aged before certification testing begins. The aging procedure shall be conducted and documented by the testing laboratory.

31.202.6.1 Catalyst-Equipped Fireplaces. Operate the catalyst-equipped fireplace using fuel described in Section (2003 Ed.)

31.203. Operate the fireplace with a new catalytic combustor in place and in operation for at least 50 hours. Record and report hourly catalyst exit temperatures, the hours of operation, and the weight of all fuel used.

31.202.6.2 Noncatalyst-Equipped Fireplaces. Operate the fireplace using the fuel described in Section 31.203 for at least 10 hours. Record and report the hours of operation and weight of all fuel used.

31.202.7 Pretest Preparation. Record the test-fuel charge dimensions, moisture content, weights, and fireplace (and catalyst if equipped) descriptions.

The fireplace description shall include photographs showing all externally observable features and drawings showing all internal and external dimensions needed for fabrication and/or construction. The drawings must be verified as representing the fireplace being tested and signed by an authorized representative of the testing laboratory.

31.202.8 Test Facility Conditions. Locate the test facility temperature monitor on the horizontal plane that includes the primary air intake opening for the fireplace. Locate the temperature monitor 3 to 6 feet (1 000 to 2 000 mm) from the front of the fireplace in the 90° sector in front of the fireplace. Test facility temperatures shall be maintained between 65° and 90°F (18° and 32°C). Use an anemometer to measure the air velocity. Measure and record the room-air velocity within 2 feet (600 mm) of the test fireplace before test initiation and once immediately following the test-burn completion. Air velocity shall be less than 50 feet/minute (250 mm/second) without the fireplace operating.

Section 31.203—Test protocol.

31.203.1 Test Fuel. Fuel shall be air dried Douglas fir dimensional lumber or cordwood without naturally associated bark. Fuel pieces shall not be less than 1/2 nor more than 5/6 of the length of the average fire chamber width. Fuel shall be split or cut into pieces with no cross-sectional dimension greater than 6 inches (152 mm). Spacers, if used, shall not exceed 3/4 inches (19 mm) in thickness and 15 percent of the test-fuel charge weight. Fuel moisture shall be in the range of 16 to 20 percent (wet basis) or 19 to 25 percent (dry basis) meter reading.

31.203.2 Test-Fuel Loading Density. The wet (with moisture) minimum weight of each test-fuel charge shall be calculated by multiplying the hearth area in square feet by 7.0 pounds per square foot (square meters x 0.30 kg/m²) (± 10 percent). Three test-fuel charges shall be prepared for each test-burn.

31.203.3 Kindling. The initial test-fuel charge of the three test-fuel charge test-burn shall be started by using a kindling-fuel charge which is up to 50 percent of the first test-fuel charge weight. Kindling-fuel pieces can be any size needed to start the fire or whatever is recommended in the manufacturer's (builder's) instructions to consumers. The kindling-fuel charge weight is not part of the initial test-fuel charge weight but is in addition to it.

31.203.4 Test-Burn Ignition. The fire can be started with or without paper. If used, the weight of the paper must be included in test-fuel charge weight. The remainder of the test-fuel charge may be added at any time after kindling ignition except that the entire first test-fuel charge must be added within 10 minutes after the start of the test (i.e., the time at which the flue-gas temperature at the 8-foot (2 440 mm) level is over 25°F (14°C) greater than the ambient temperature of the test facility).

31.203.5 Test Initiation. Emissions and flue-gas sampling are initiated immediately after the kindling has been ignited and when flue-gas temperatures in the center of the flue at an elevation of 8 feet (2 440 mm) above the base (floor) of the fire chamber reach 25°F (14°C) greater than the ambient temperature of the test facility.

31.203.6 Sampling Parameters. Sampling (from the 8-foot [2 440 mm] flue-gas temperature measurement location) must include:

1. Particulate Emissions
2. Carbon Dioxide (CO₂)¹
3. Carbon Monoxide (CO)¹
4. Oxygen (O₂)¹
5. Temperature(s)

¹ These gases shall be measured on-line (real-time) and recorded at a frequency of not less than once every 5 minutes. These 5-minute readings are to be arithmetically averaged over the test-burn series or alternatively, a gas bag sample can be taken at a constant sample rate over the entire test-burn series and analyzed for the required gases within one hour of the end of the test-burn.

If a fireplace is equipped with an emissions control device which is located downstream from the 8-foot (2 440 mm) flue-gas temperature measurement location, a second temperature, particulate, and gaseous emissions sampling location must be located downstream from the emissions control device but not less than 4 flue diameters upstream from the flue exit to the atmosphere. The two sampling locations must be sampled simultaneously during testing for each fireplace configuration being tested.

31.203.7 Test-Fuel Additions and Test Completion. The second and third test-fuel charges for a test-burn may be placed and burned in the fire chamber at any time deemed reasonable by the operator or when recommended by the manufacturer's and/or builder's instructions to consumers.

No additional kindling may be added after the start of a test-burn series and the flue-gas temperature at the 8-foot (2 440 mm) level above the base of the hearth must always be 25°F (14°C) greater than the ambient temperature of the test facility for a valid test-burn series. Each entire test-fuel charge must be added within 10 minutes from the addition of the first piece.

A test (i.e., a three test-fuel charge test-burn series) is completed and all sampling and measurements are stopped when all three test-fuel charges have been consumed (to more than 90 percent by weight) in the firebox and the 8-foot (2 440 mm) level flue-gas temperature drops below 25°F (14°C) greater than the ambient temperature of the test facility.

Within 5 minutes after the test-burn is completed and all measurements and sampling has stopped, the remaining coals and/or unburned fuel, shall be extinguished with a carbon dioxide fire extinguisher. All of the remaining coals, unburned fuel, and ash shall be removed from the firebox and weighed to the nearest 0.1 pound (0.05 kg). The weight of these unburned materials and ash shall be subtracted from the total test-burn fuel weight when calculating the test-burn burn rate. A test-burn is invalid if less than 90 percent of the weight of the total test-fuel charges plus the kindling weight have been consumed in the fireplace firebox.

31.203.8 Test-Fuel Charge (Load) Adjustments. Test-fuel charges may be adjusted (i.e., repositioned) once during the burning of each test-fuel charge. The time used to make this adjustment shall be less than 15 seconds.

31.203.9 Air Supply Adjustment. Air supply controls, if the fireplace is equipped with controls, may not be adjusted during any test-burn series after the first 10 minutes of startup of each fuel load. All air supply settings must be set to the lowest level at the start of a test and shall remain at the lowest setting throughout a test-burn.

31.203.10 Auxiliary Fireplace Equipment Operation. Heat exchange blowers (standard or optional) sold with the fireplace shall be operated during all test-burns following the manufacturer's written instructions. If no manufacturer's written instructions are available, operate the heat exchange blower in the "high" position. (Automatically operated blowers shall be operated as designed.) Shaker grates, by-pass controls, afterburners, or other auxiliary equipment may be adjusted only once per test-fuel charge following the manufacturer's written instructions. Record and report all adjustments on a fireplace operational written-record.

31.203.11 Fireplace Configurations. One, 3 test-fuel charge test-burn shall be conducted for each of the following fireplace operating configurations:

1. Door(s) closed, with hearth grate;
2. Door(s) open, with hearth grate;
3. Door(s) closed, without hearth grate;
4. Door(s) open, without hearth grate; and
5. With no doors, and draft inducer on.

No test-burn series is necessary for any configuration the appliance design cannot or is not intended to accommodate. If a configuration is not tested, the reason must be submitted with the test report and the appliance label must state that the appliance cannot be used in that configuration by consumer users.

One emission factor result, or one emission factor average, as provided in paragraph 31.203.11.2, from each fireplace configuration tested shall be compiled into an arithmetic average of all the configurations tested for determining compliance with the requirements of paragraph 31.204.2.

31.203.11.1 Closed-Door(s) Testing. For all closed-door test configurations, the door(s) must be closed within 10 minutes

from the addition of the first test-fuel piece of each test-fuel charge in a test-burn. During a test-burn, the door(s) cannot be re-opened except during test-fuel reload and adjustment as referenced in Sections 31.203.7 and 31.203.8.

31.203.11.2 Additional Test-Burn. The testing laboratory may conduct more than one test-burn series for each of the applicable configurations specified in Section 31.203.11. If more than one test-burn is conducted for a specified configuration, the results from at least 2/3 of the test-burns for that configuration shall be used in calculating the arithmetic average emission factor for that configuration. The measurement data and results of all tests conducted shall be reported regardless of which values are used in calculating the average emission factor for that configuration.

31.203.12 Emissions Sampling System (ESS).

31.203.12.1 Principle. Figure 31-2-1 shows a schematic of an ESS for sampling solid-fuel-fired fireplace emissions. Except as specified in Section 31.202.4, an ESS in this configuration shall be used to sample all fireplace emissions. The ESS shall draw flue gases through a 15 inch (380 mm) long, 3/8 inch (10 mm) O.D. stainless steel probe which samples from the center of the flue at an elevation which is 8 feet (2 440 mm) above the floor of the firebox (i.e., the hearth). A flue-gas sample shall then travel through a 3/8 inch (10 mm) O.D. Teflon® tube, and a heated U.S. EPA Method 5-type glass-fiber filter (40 CFR Part 60, Appendix A) for collection of particulate matter. The filter shall be followed by an in-line flow-through cartridge containing 20 grams of XAD-2 sorbent resin for collecting semi-volatile hydrocarbons. Water vapor shall then be removed from the sampled gas by a silica-gel trap. Flue-gas oxygen concentrations, which shall be used to determine the ratio of flue-gas volume to the amount of fuel burned, are measured within the ESS system by an elec-

trochemical cell meeting the performance specifications presented in Section 31.202.3.8 (1.).

The ESS shall use a critical orifice to maintain a nominal flue-gas sampling rate of 0.035 cfm (0.0167 liters per second). The actual flow rate through each critical orifice shall be determined to within 0.000354 cubic feet (0.01 liters) per second before and after each test-burn with a bubble flow meter to document exact sampling rates. The post-test-burn critical-orifice flow-rate determinations shall be performed before the ESS is dismantled for sample recovery and cleanup. Pre-test-burn and post-test-burn critical-orifice flow-rate measurements shall be within 0.0000117 cubic feet (0.00033 liters) per second of each other or the test-burn emissions results shall be invalid. Temperatures shall be monitored using type K ground-isolated, stainless-steel-sheathed thermocouples.

The ESS unit shall return particle-free and dry exhaust gas to the flue via a 1/4 inch (6 mm) Teflon® line and a 15 inch (380 mm) stainless steel probe inserted into the flue. A subsample aliquot of the flue-gas sample-gas stream exiting the ESS unit, shall be pumped into a 1 cubic foot (29 liter) Tedlar® bag for measuring the average carbon dioxide, carbon monoxide, and confirmation of average oxygen concentrations for the test period. Flow to the subsample gas bag shall be controlled by a solenoid valve connected to the main pump circuit and a fine-adjust needle-controlled flow valve. The solenoid valve shall be open only when the pump is activated, allowing the subsample gas to be pumped into the gas bag at all times when the ESS pump is on. The rate of flow into the bag shall be controlled by the fine-adjust metering needle-valve which is adjusted at setup so that 4.7 to 5.2 gal (18 to 20 liters) of gas is collected over the entire 3 test-fuel charge test-burn without over-pressurizing the gas sample bag.

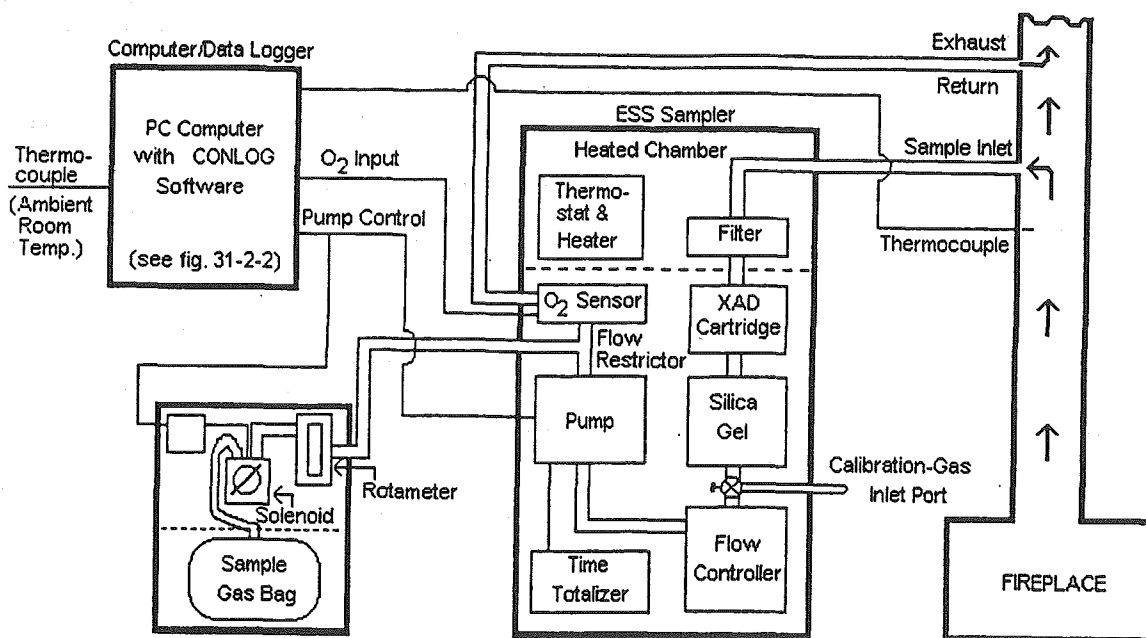

Figure 31-2-1. Schematic of ESS/Data Logger system.

31.203.12.2 The Data Acquisition and Control System. The data acquisition and control system for the ESS is shown in Figure 31-2-2. This system consists of a personal computer (PC) containing an analog-to-digital data processing board (12-bit precision), a terminal (connection) box, and specialized data acquisition and system control software (called CONLOG).

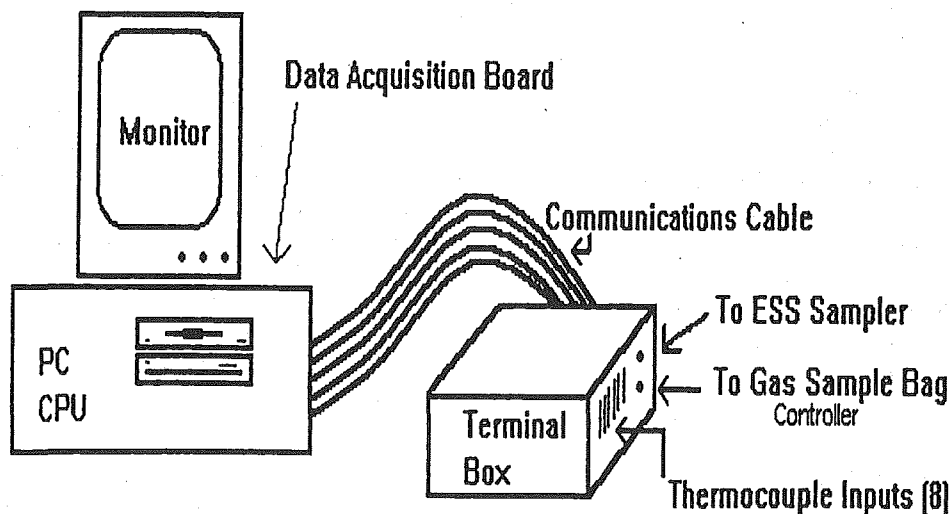

Figure 31-2-2. ESS data logger system.

For fireplace testing, the CONLOG software is configured to control, collect, and store the following data:

1. Test-period starting and ending times and dates, and total length of sampling period,
2. Pump-cycle on/off, cycle length and thermocouple (TC) cycle recording interval (frequency),
3. Temperature records, including flue-gas and ambient temperatures, averaged over pre-selected intervals,
4. Date, times, and weights of each added fuel load, and
5. Flue-gas oxygen measurements taken during each sample cycle.

During testing, instantaneous readings of real-time data shall be displayed on the system status screen. These data shall include the date, time, temperatures for each of the TCs, and flue-gas oxygen concentrations. The most recent 15 sets of recorded data shall also be displayed.

Flue-gas sampling and the recording of flue-gas oxygen concentrations shall only occur when flue-gas temperatures are above 25°F (14°C) greater than the ambient temperature of the test facility. Temperatures and fueling shall always be recorded at five-minute intervals regardless of flue-gas temperature. The ESS sampling-pump operating cycle shall be adjustable as described in Section 31.203.12.3.

31.203.12.3 ESS Sampling-Pump Operating Cycle. The ESS sampling-pump operating cycle shall be adjusted to accommodate variable test-fuel charge sizes, emission factors, and the length of time needed to complete a test-burn series. The sampler-pump operation shall be adjustable from 1 second to 5 minutes (100 percent) "on" for every 5-minute test-burn data-recording interval. This will allow adjustment for the amount of anticipated emissions materials that will be sampled and deposited on the ESS filter, XAD-2, and the

other system components. It is recommended that the minimum sample quantities stipulated in Section 31.203.12.4 be used to calculate the appropriate pump cycle "on" and "off" periods. It should be noted that if the sampler collects too much particulate material on the filter and in the XAD-2 cartridge, the unit may fail the sample flow calibration check required at the end of each test-burn.

31.203.12.4 Minimum Sample Quantities. For each complete 3 test-fuel charge test-burn, the ESS must catch a minimum total particulate material mass of at least 0.231 grains (15 mg). Alternatively, the ESS must sample a minimum of 10 cubic feet (283 liters) during each 3 test-fuel charge test-burn. If this volume cannot be sampled in the test-burn time period, two ESS samplers must be utilized to sample fireplace emissions simultaneously during each test-burn. If emissions results from the two ESSs are different by more than 10 percent of the lower emissions-factor result, the test-burn results are invalid. An arithmetic average is calculated for test-burn results when two ESSs are utilized.

31.203.12.5 Equipment Preparation and Sample Processing Procedures.

31.203.12.5.1. Prior to emissions testing, the ESS unit shall be prepared with a new, tared glass-fiber filter and a clean XAD-2 sorbent-resin cartridge. Within 3 hours after testing is completed, the stainless steel sampling probe, Teflon® sampling line, filter holder, and XAD-2 cartridge(s) shall be removed from the test site and transported to the laboratory for processing. Each component of the ESS sampler shall be processed as follows:

1. Filter: The glass fiber filter (4 inches (102 mm) in diameter) shall be removed from the ESS filter housing and placed in a petri dish for desiccation and gravimetric analysis.

2. XAD-2 sorbent-resin cartridge: The sorbent-resin cartridge shall be extracted in a Soxhlet extractor with dichloromethane for 24 hours. The extraction solution shall be transferred to a tared glass beaker and evaporated in an ambient-air dryer. The beaker with dried residue shall then be desiccated to constant weight (less than ± 0.5 mg change within a 2-hour period), and the extractable residue shall be weighed.

3. ESS hardware: All hardware components which are in the flue-gas sample stream (stainless steel probe, Teflon® sampling line, stainless steel filter housing, and all other Teflon® and stainless steel fittings) through the top of the sorbent-resin cartridge, shall be cleaned with a solvent mixture of 50 percent dichloromethane and 50 percent methanol. The cleaning solvent solutions shall be placed in tared glass beakers, evaporated in an ambient-air dryer, desiccated to constant weight (less than ± 0.5 mg change within a 2-hour period), and weighed.

EPA Method 5H procedures (40 CFR Part 60, Appendix A) for desiccation and weighing time intervals shall be followed for steps 1 through 3 above.

31.203.12.5.2 The ESS shall be serviced both at the start and end of a fireplace testing period. During installation, leak checks shall be performed; the thermocouples, fuel-weighing scale, and oxygen-cell shall be calibrated, and the data logger shall be programmed. At the end of the test period, final calibration, and leak-check procedures shall again be performed, and the ESS sampling line, filter housing, XAD-2 cartridge, sampling probe, and Tedlar® bag shall be removed, sealed, and transported to the laboratory for analysis. If the pre-test and post-test leak checks of the ESS system exceed 0.00033 liters per second, the test-burn emission results shall be invalid.

$$\text{Particulate emission factor (g/kg)} = \frac{(\text{Particulate Catch}) \times (\text{Stoichiometric Volume}) \times (\text{Flue-gas Dilution Factor})}{(\text{Sampling Time}) \times (\text{Sampling Rate})}$$

WHERE:

1. Particulate Catch: The total mass, in grams, of particulate material caught on the filter, in the XAD-2 resin cartridge (semi-volatile compounds); and in the probe clean-up and rinse solutions.

2. Stoichiometric Volume: Stoichiometric volume is the volume of dry air needed to completely combust one dry kilogram of fuel with no "excess air." This value is determined by using a chemical reaction balance between the specific fuel being used and the chemical components of air. The stoichi-

31.203.12.6 Data Processing and Quality Assurance.

31.203.12.6.1 Upon returning to the laboratory facilities, the data file (computer disk) shall be reviewed to check for proper equipment operation. The data-logger data files, log books, and records maintained by field staff shall be reviewed to ensure sample integrity.

The computer-logged data file shall be used in conjunction with the ESS particulate samples and sample-gas bag analyses to calculate the emission factor, emission rate, and fireplace operational parameters. An example ESS results report is presented in Table 31-2-A.

31.203.12.6.2 Burning Period. The total burning period is calculated by:

$$\text{Total Burning Period} = (\text{Length of each sample cycle}) \times (\text{Number of flue temperature readings over } 25^{\circ}\text{F (} 14^{\circ}\text{C) greater than the ambient temperature of the test facility}).$$

WHERE:

1. Length of each sample cycle: The time between each temperature recording as configured in the CONLOG software settings (standardized at 5 minutes).

2. Number of flue temperature readings during fireplace use: The total number of temperature readings when the calibrated temperature value was more than 25°F (14°C) greater than the ambient temperature of the test facility.

31.203.12.6.3 Particulate Emissions.

31.203.12.6.3.1 ESS Particulate Emission Factor. The equation for the total ESS particulate emission factor for each test-burn presented below produces reporting units of grams per dry kilogram of fuel burned (g/kg):

ometric volume for Douglas fir is 86.78 cubic feet per pound (5 404 liters per dry kilogram) at 68°F (20°C) and 29.92 inches (760 mm) of mercury pressure.

3. Flue-gas Dilution Factor: The degree to which the sampled combustion gases have been diluted in the flue by air in excess of the stoichiometric volume (called excess air). The dilution factor is obtained by using the average sampled carbon dioxide and carbon monoxide values obtained from the sample gas bag analyses and the following equation.

$$\frac{18.53 + ((1 - (\text{CO}_2 + 1/2 \text{CO})) \times 2.37)}{18.53}$$

$$\text{Flue-Gas Dilution Factor} = \frac{18.53 + ((1 - (\text{CO}_2 + 1/2 \text{CO})) \times 2.37)}{18.53}$$

Note: Multiplying the g/kg emission factor by the burn rate (dry kg/hr) yields particulate emissions in grams per hour (g/hr). Burn rate is calculated by the following equation:

$$\text{Burn Rate (kg/hr)} = \frac{\text{Total Fuel (kg)}}{\text{Total Burn Period (hours)}}$$

WHERE:

Total Fuel is the total fuel added during the entire test-burn minus the remaining unburned materials at the end of the test-burn.

4. Sampling Time: The number of minutes the sampler pump operated during the total test-burn period.

5. Sampling Rate: Sampling rate is controlled by the critical orifice installed in the sampler. The actual calibrated sampling rate is used here.

31.203.12.6.3.2 EPA Method 5H Particulate Emissions. ESS-measured emissions factors submitted to DOE for approval must first be converted to U.S. EPA Method 5H equivalents. The ESS particulate emissions factor results

obtained in Section 31.203.12.6.1 are converted to be equivalent to the U.S. EPA Method 5H emissions factor results by the following equation:

$$1.254 + (0.302 \times \text{PEF}) + (1.261 \times 10^{-\text{PEF}})$$

WHERE:

PEF is the ESS-measured particulate emission factor for a test-burn.

31.203.12.6.4 CO Emissions. The carbon monoxide (CO) emission factor equation produces grams of CO per dry kilogram of fuel burned. The grams per kilogram equation includes some equation components described above.

$$\text{CO emission factor (g/kg)} = \frac{(\text{Fraction CO}) \times (\text{Stoich. Volume}) \times (\text{Dilution Factor}) \times (\text{Molecular Weight of CO})}{(24.45 \text{ L/mole})}$$

WHERE:

1. Fraction CO: The fraction of CO measured in the gas sampling bag.

Note: Percent CO divided by 100 gives the fraction CO.

2. Molecular Weight of CO: The gram molecular weight of CO, 28 pounds per pound-mole (28.0 g/g-mole).

Multiplying the results of the above equation by the burn rate (dry kg/hr) yields the grams per hour (g/hr) CO emission rate.

Table 31-2-A Example ESS Data Results Format

ESS Emission Results			
Test Facility Location:		xxxx	
Test Laboratory:		xxxx	
Test-Burn Number:		xxxx	
Start Time/Date:		xxxx	
End Time/Date:		xxxx	
Fireplace Model:		xxxx	
TIME			
Total Test Period	152.3 hours	CARBON MONOXIDE EMISSIONS	
Total Burn Time	64.6 hours	Gram/Kilogram	48.0 g/kg
Flue >25 Degrees F above ambient temperature	42.4 %	Gram/Hour	64.0 g/hr
		Gram/Cubic Meter	1.25 g/m ³
ESS SETTINGS			
ESS Sample Rate	1.004 l/min	AVERAGE TEMPERATURES	
Sample Cycle	5.0 min	Fuel-Gas Temperatures	275 °F
Sample Time / Sample Cycle	0.443 min	Flue Exit Temperature	135 °C
			308 °F
			154 °C
		Test Facility Ambient Temperature	66 °F
			19 °C
TEST FUEL			
Total Fuel Used (wet weight)	101.3 kg	AVERAGE FLUE-GAS CONCENTRATIONS	
Ave. Fuel Moisture (dry basis)	17.7 %	Flue Oxygen (SE)	18.15 %
Total Fuel Used (dry weight)	86.1 kg	Flue Oxygen (gas bag or analyzer)	18.05 %
Average Test-Fuel Charge	14.5 kg	Flue CO (gas bag or analyzer)	0.10 %
Average Burn Rate	1.33 dry kg/hr	Flue CO ₂ (gas bag or analyzer)	2.60 %
PARTICULATE EMISSIONS (EPA Method 5H Equivalents)			
Gram/Kilogram	2.6 g/kg	BREAKDOWN OF ESS PARTICULATE SAMPLE	
Gram/Hour	3.4 g/hr	Rinse	25.5 mg
Gram/Cubic Meter	0.06 g/m ³	XAD	6.3 mg
		Filter	15.7 mg
		Blank	0.0 mg
		TOTAL	47.4 mg

Notes:

NM = Not Measured, NA = Not Applicable, NU = Not Used

Total time flue temperature greater than 25°F over ambient temperature.

TEST PERFORMED BY: XYZ Testing International, Olympia Washington, 98504

31.203.13 Calibrations.

31.203.13.1 Balance. Before each certification test, the balance used for weighing test-fuel charges shall be audited by weighing at least one calibration weight (Class F) that corresponds to 20 percent to 80 percent of the expected test-fuel charge weight. If the scale cannot reproduce the value of the calibration weight within 0.1 lb (0.05 kg) or 1 percent of the expected test-fuel charge weight, whichever is greater, re-calibrate the scale before use with at least five calibration weights spanning the operational range of the scale.

31.203.13.2 Temperature Monitor. Calibrate the temperature monitor before the first certification test and semiannually thereafter.

31.203.13.3 Fuel Moisture Meter. Calibrate the fuel moisture meter as per the manufacturer's instructions before each certification test.

31.203.13.4 Anemometer. Calibrate the anemometer as specified by the manufacturer's instructions before the first certification test and semiannually thereafter.

31.203.13.5 Barometer. Calibrate the barometer against a mercury barometer before the first certification test and semiannually thereafter.

31.203.13.6 Draft Gauge. Calibrate the Draft Gauge as per the manufacturer's instructions; a liquid manometer does not require calibration.

31.203.13.7 ESS. The ESS shall be calibrated as specified in Section 31.203.12.1.

31.203.14 Reporting Criteria. Submit both raw and reduced data for all fireplace tests. Specific reporting requirements are as follows:

31.203.14.1 Fireplace Identification. Report fireplace identification information including manufacturer, model, and serial number. Include a copy of fireplace installation and operation manuals.

31.203.14.2 Test Facility Information. Report test facility location, temperature, and air velocity information.

31.203.14.3 Test Equipment Calibration and Audit Information. Report calibration and audit results for the test-fuel balance, test-fuel moisture meter, analytical balance, and sampling equipment including volume metering systems and gaseous analyzers.

31.203.14.4 Pretest Information and Conditions. Report all pretest conditions including test-fuel charge weight, fireplace temperatures, and air supply settings.

31.203.14.5 Particulate Emission Data. Report a summary of test results for all test-burns conducted and the arithmetically averaged emission factor for all test-burns used for certification. Submit copies of all data sheets and other records collected during the testing. Submit examples of all calculations.

31.203.14.6 Required Test Report Information and Suggested Format. Test report information requirements to be provided to DOE for approval/certification of fireplaces are presented in this Standard. The requirements are presented here in a recommended report format.

31.203.14.6.1 Introduction.

1. Purpose of test: Certification or audit.
2. Fireplace identification: Manufacturer, model number, catalytic/noncatalytic, and options. Include a copy of fireplace installation and operation manuals.
3. Laboratory: Name, location, and participants.
4. Test information: Date fireplace was received, date of tests, sampling methods used, and number of test-burns.

31.203.14.6.2 Summary and Discussion of Results.

1. Table of results: Test-burn number, burn rate, particulate emission factor (in U.S. EPA Method 5H equivalents), efficiency (if determined), and averages (indicate which test-burns are used).
2. Summary of other data: Test facility conditions, surface temperature averages, catalyst temperature averages, test-fuel charge weights, and test-burn times.
3. Discussion: Specific test-burn problems and solutions.

31.203.14.6.3 Process Description.

1. Fireplace dimensions: Volume, height, width, lengths (or other linear dimensions), weight, and hearth area.
2. Firebox configuration: Air supply locations and operation, air supply introduction location, refractory location and dimensions, catalyst location, baffle and by-pass location and operation (include line drawings and photographs).
3. Process operation during test: Air supply settings and adjustments, fuel bed adjustments, and draft.
4. Test fuel: Test fuel properties (moisture and temperature), test fuel description (include line drawing or photograph), and test fuel charge density.

31.203.14.6.4 Sampling Locations. Describe sampling location relative to fireplace. Include linedrawings and photographs.

31.203.14.6.5 Sampling and Analytical Procedures.

1. Sampling methods: Brief reference to operational and sampling procedures, and optional and alternative procedures used.

2. Analytical methods: Brief description of sample recovery and analysis procedures.

31.203.14.6.6 Quality Control and Assurance Procedures and Results.

1. Calibration procedures and results: Certification, sampling, and analysis procedures.

2. Test method quality control procedures: Leak-checks, volume-meter checks, stratification (velocity) checks, and proportionality results.

31.203.14.6.7 Appendices.

1. **Results and Example Calculations.** Include complete summary tables and accompanying examples of all calculations.

2. **Raw Data.** Include copies of all uncorrected data sheets for sampling measurements, temperature records, and sample recovery data. Include copies of all burn rate and fireplace temperature data.

3. **Sampling and Analytical Procedures.** Include detailed description of procedures followed by laboratory personnel in conducting the certification test, emphasizing particularly, parts of the procedures differing from the prescribed methods (e.g., DOE approved alternatives).

4. **Calibration Results.** Summary of all calibrations, checks, and audits pertinent to certification test results including dates.

5. **Participants.** Test personnel, manufacturer representatives, and regulatory observers.

6. **Sampling and Operation Records.** Copies of uncorrected records of activities not included on raw data sheets (e.g., fireplace door open times and durations).

7. **Additional Information.** Fireplace manufacturer's written instructions for operation during the certification test and copies of the production-ready (print-ready) temporary and permanent labels required in Section 31.208 shall be included in the test report prepared by the test laboratory.

31.203.14.7 References.

1. Code of Federal Regulations, U.S. EPA Title 40, Part 60, Subpart AAA and Appendix A (40 CFR Part 60).

2. Barnett, S. G. and P. G. Fields, 1991, "In-Home Performance of Exempt Pellet Stoves in Medford, Oregon," prepared for U.S. Department of Energy, Oregon Department of Energy, Tennessee Valley Authority, and Oregon Department of Environmental Quality, July 1991.

3. Barnett, S. G. and R. R. Roholt, 1990, "In-Home Performance of Certified Pellet Stoves in Medford and Klamath Falls, Oregon," prepared for the U.S. Department of Energy, 1990.

4. Barnett, S. G., 1990, "Field Performance of Advanced Technology Woodstoves in Glens Falls, New York, 1988-1989," for New York State Energy Research and Develop-

ment Authority, U.S. EPA, Coalition of Northeastern Governors, Canadian Combustion Research Laboratory, and the Wood Heating Alliance, December 1989.

Section 31.204—Approval procedure for fireplaces.

On or after the effective date of this regulation, a manufacturer or builder of a fireplace who wishes to have a fireplace model line or fireplace design designated as an approved (or certified) fireplace, shall submit to DOE for its review the following information:

31.204.1 Manufacturer name and street address, model or design identification, construction specifications, and drawings of the firebox and required chimney system.

31.204.2 A test report prepared in accordance with Section 31.203.14.6 showing that testing has been conducted by a DOE approved and U.S. EPA accredited laboratory, and that the arithmetically averaged particulate emission factors for that fireplace model line or design, tested in accordance with UBC Standard Section 31.202, does not exceed 7.3 g/kg (U.S. EPA Method 5H equivalent as determined in Section 31.203.12.6.3.2) for a factory-built fireplace model lines or designs or 12.0 g/kg (U.S. EPA Method 5H equivalent as determined in Section 31.203.12.6.3.2) for new certified masonry fireplace model lines or designs. After January 1, 1999, particulate emission factors for factory-built and new certified masonry fireplace model lines or designs shall not exceed 7.3 g/kg (U.S. EPA Method 5H equivalents as determined in Section 31.203.12.6.3.2).

Section 31.205—Approval of nontested fireplaces.

On or after the effective date of this regulation, DOE may grant approval for a fireplace model line or design that has not been tested pursuant to Section 31.204 upon submission of the following by the applicant:

31.205.1 Manufacturer name and street address, model or design identification, construction specifications, and drawings of the internal assembly system.

31.205.2 Documentation from an EPA accredited laboratory that the model is a fireplace within the definition of this regulation, has substantially the same core construction as a model already tested by a DOE approved and EPA accredited laboratory, and is substantially similar to the approved model in internal assembly design, combustion function, and probable emissions performance as listed in Section 31.204.2.

Section 31.206—Approval through alternative test protocol.

As provided in Section 31.202.4, an alternative testing protocol may be submitted by a DOE approved and EPA accredited laboratory for acceptance by DOE as equivalent to Uniform Building Code Standard 31-2.

Section 31.207—Approval termination.

All fireplace model line or design approvals shall terminate five years from the approval date. Previously approved fireplace model line and/or design may be granted re-

approval (re-certification) upon application to and review by DOE. No testing shall be required for fireplace model line or design re-approvals unless DOE determines that design changes have been incorporated into the fireplace that could adversely affect the emissions factor, or testing is otherwise stipulated by DOE.

DOE may revoke a fireplace model line or design approval certification if it is determined that the fireplaces being produced in a specific model line do not comply with the requirements of Section 31.200. Such a determination shall be based on all available evidence, including:

1. Test data from a retesting (audit test) of the original unit on which the certification test was conducted or a sample unit from the current model line;
2. A finding that the certification test was not valid;
3. A finding that the labeling of the fireplace does not comply with the requirements of Section 31.200;
4. Failure by the fireplace manufacturer (builder) to comply with reporting and record keeping requirements under Section 31.200;
5. Physical examination showing that a significant percentage of production units inspected are not similar in all material respects to the fireplace submitted for testing; or
6. Failure of the manufacturer to conduct a quality assurance program in conformity with Section 31.208.

Revocation of certification under this section shall not take effect until the manufacturer (builder) concerned has been given written notice by DOE setting forth the basis for the proposed determination and an opportunity to request a hearing.

Section 31.208—Quality control.

Once within 30 days of each annual anniversary after the initial approval/certification, a DOE approved and U.S. EPA accredited laboratory shall inspect the most recently produced fireplace of an approved model line or design at its manufacturing location (site, if site-built) to document adherence to the approved/certified fireplace design specifications. If no fireplaces of an approved model line or design were produced (built) during the previous 12 months, no inspection is required.

An inspection report for each approved fireplace model line or design must be submitted to DOE within 30 days after the inspection date. The inspection report shall include, as a minimum, the model identification and serial number of the fireplace inspected, the location where the model was inspected, the names of the manufacturer's and/or builder's representatives present, the date of inspection, and a description of any changes made to the approved fireplace model line or design since the last inspection. The U.S. EPA accredited laboratory which conducts the annual quality control inspection is responsible for auditing the content and format of all labels to be applied to approved fireplaces as stipulated in Section 31.209.

(2003 Ed.)

A fireplace model line or design shall be re-tested in accordance with Section 31.202 if it is determined during inspection that design changes have been incorporated into the approved/certified fireplace design which adversely affect the fireplace particulate emissions factor. Design elements which can affect fireplace particulate emissions include:

1. Grate placement and height;
2. Air supply minimum and maximum controls;
3. Usable hearth area; and
4. Firebox height, width, and length dimensions.

Section 31.209—Permanent label, temporary label and owner's manual.

31.209.1 Labels and the Owner's Manual. Labels and owner's manual shall be prepared and installed in all certified "For Sale" fireplaces as specified in U.S. EPA 40 CFR Part 60, Section 60.536. Information that shall be presented on all labels includes:

1. Manufacturer's or builder's name, address, and phone number;
2. Model number and/or name;
3. Month and year of manufacture;
4. Starting and ending dates for the 5-year approval period;
5. If a fireplace was tested and approved with an emissions control device which is not an integral part of the fireplace structure, the label shall state that "The fireplace can not be sold or installed without the specified emissions control device in place and operational.";

6. On certified fireplaces the statement: "This appliance has been tested and has demonstrated compliance with Washington State amendment to the UBC Standard, Chapter 31-2 requirements."

Section 31.210—List of approved fireplaces.

DOE shall maintain a list of approved fireplace model lines and designs, and that list shall be available to the public.

[Statutory Authority: RCW 19.27.031, 19.27.074, 01-02-095, § 51-40-31200, filed 1/3/01, effective 7/1/01; 98-02-054, § 51-40-31200, filed 1/6/98, effective 7/1/98.]

Reviser's note: The brackets and enclosed material in the text of the above section occurred in the copy filed by the agency.

WAC 51-40-3404 Section 3404—Moved buildings.

Buildings or structures moved into or within a jurisdiction shall comply with the provisions of this code, the Uniform Mechanical Code (chapter 51-42 WAC), the Uniform Fire Code and Standards (chapters 51-44 and 51-45 WAC), the Uniform Plumbing Code and Standards (chapters 51-46 and 51-47 WAC), the Washington State Energy Code (chapter 51-11 WAC) and the Washington State Ventilation and Indoor Air Quality Code (chapter 51-13 WAC) for new buildings or structures.

[Title 51 WAC—p. 193]

EXCEPTION: Group R, Division 3 buildings or structures are not required to comply if:

1. The original occupancy classification is not changed, and
2. The original building is not substantially remodeled or rehabilitated. For the purposes of this section a building shall be considered to be substantially remodeled when the costs of remodeling exceed 60 percent of the value of the building exclusive of the costs relating to preparation, construction, demolition or renovation of foundations.

[Statutory Authority: RCW 19.27.031 and 19.27.074. 98-02-054, § 51-40-3404, filed 1/6/98, effective 7/1/98.]

WAC 51-40-93115 Section 93115.

**THIS APPENDIX IS FOR REFERENCE ONLY.
IT IS NOT THE RESPONSIBILITY OF THE BUILDING
OFFICIAL TO ENFORCE IT.**

APPENDIX CHAPTER 11 DIVISION I

U.S. DEPARTMENT OF HOUSING AND URBAN DEVELOPMENT FEDERAL FAIR HOUSING ACT GUIDELINES FOR SITE TERRAIN EXEMPTIONS

93115.1 Purpose. The purpose of this division is to provide the United States Department of Housing and Urban Development Federal Fair Housing Act Guidelines for Site Terrain Exemptions.

93115.2 Scope.

93115.2.1 General. The provisions of this division may apply to all buildings and dwelling units that are regulated by the Federal Fair Housing Act Amendments of 1988.

93115.2.2 Applicability of other provisions. Except as specifically allowed by this division for determining site terrain exemptions, Group R, Division 1 apartment houses shall meet all applicable provisions of this code.

93115.3 Definitions. For the purpose of this division, certain terms are defined as follows:

COVERED MULTIFAMILY DWELLINGS means buildings consisting of four or more dwelling units if such buildings have one or more elevators; and ground floor dwelling units in other buildings consisting of four or more dwelling units. Dwelling units within a single structure separated by firewalls do not constitute separate buildings.

FINISHED GRADE means the ground surface of the site after all construction, leveling, grading, and development has been completed.

UNDISTURBED SITE means the site before any construction, leveling, grading, or development associated with the current project.

93115.4 Site Impracticality.

93115.4.1 General. Covered multifamily dwellings with elevators shall be designed and constructed to provide at least one accessible entrance on an accessible route, regardless of terrain or unusual characteristics of the site. Covered multifamily dwellings without elevators shall be designed and constructed to provide at least one accessible entrance on an

accessible route unless terrain or unusual characteristics of the site are such that the following conditions are found to exist:

A. Site Impracticality Due to Terrain. There are two alternative tests for determining a site impracticality due to terrain: The individual building test provided in paragraph (1), or the site analysis test provided in paragraph (2). These tests may be used as follows.

A site with a single building having a common entrance for all units may be analyzed only as described in paragraph (1).

All other sites, including a site with a single building having multiple entrances serving either individual dwellings units or clusters of dwelling units, may be analyzed using the methodology in either paragraph (1) or paragraph (2). For these sites for which either test is applicable, regardless of which test is selected, at least 20% of the total ground floor units in nonelevator buildings, on any site, must comply with the guidelines.

1. Individual Building Test. It is impractical to provide an accessible entrance served by an accessible route when the terrain of the site is such that:

1.1. The slopes of the undisturbed site measured between the planned entrance and all vehicular or pedestrian arrival points within 50 feet (15 m) of the planned entrance exceed 10 percent.

1.2. The slopes of the planned finished grade measured between the entrance and all vehicular or pedestrian arrival points within 50 feet (15 m) of the planned entrance also exceed 10 percent.

If there are no vehicular or pedestrian arrival points within 50 feet (15 m) of the planned entrance, the slope for the purpose of this paragraph (1) will be measured to the closest vehicular or pedestrian arrival point.

For purposes of these guidelines, vehicular or pedestrian arrival points include public or resident parking areas; public transportation stops; passenger loading zones; and public streets or sidewalks. To determine site impracticality, (1) the slope would be measured at ground level from the point of the planned entrance, or (2) if there are no vehicular or pedestrian arrival points close to the planned entrance. In the case of sidewalks, the closest point to the entrance will be where a public sidewalk entering the site intersects with the sidewalk to the entrance. In the case of resident parking areas, the closest point to the planned entrance will be measured from the entry point to the parking area that is located closest to the planned entrance.

2. Site Analysis Test. Alternatively, for a site having multiple buildings, or a site with a single building with multiple entrances, impracticality of providing an accessible entrance served by an accessible route can be established by the following steps:

2.1. The percentage of the total buildable area of the undisturbed site with a natural grade less than 10% slope shall be calculated. The analysis of the existing slope (before

grading) shall be done on a topographic survey with two foot (610 mm) contour intervals with slope determination made between each successive interval. The accuracy of the slope analysis shall be certified by a professional licensed engineer, landscape architect, architect, or surveyor.

2.2. To determine the practicality of providing accessibility to planned multifamily dwellings based on the topography of the existing natural terrain, the minimum percentage of ground floor units to be made accessible should equal the percentage of the total buildable area (not including floodplain, wetlands, or other restricted use areas) of the undisturbed site that has an existing natural grade of less than 10% slope.

2.3. In addition to the percentage established in paragraph 2.2, all ground floor units in a building, or ground floor units served by a particular entrance, shall be made accessible if the entrance to the units is on an accessible route, defined as a walkway with a slope between the planned entrance and a pedestrian or vehicular arrival point that is no greater than 8.33%.

B. Site Impracticality Due to Unusual Characteristics. Unusual characteristics include sites located in a federally-designated floodplain or coastal high-hazard area and sites subject to other similar requirements of law or code that the lowest structural member of the lowest floor must be raised to a specified level at or above the base flood elevation. An accessible route to a building entrance is impractical due to unusual characteristics of the site when:

1. The unusual site characteristics result in a difference in finished grade elevation exceeding 30 inches (760 mm) and 10 percent measured between an entrance and all vehicular or pedestrian arrival points within 50 feet (15 m) of the planned entrance; or

2. If there are no vehicular or pedestrian arrival points within 50 feet (15 m) of the planned entrance, the unusual characteristics result in a difference in finished grade elevation exceeding 30 inches (760 mm) and 10 percent measured between an entrance and the closest vehicular or pedestrian arrival point.

93115.4.2 Exceptions to site impracticality. Regardless of site considerations described in Section 93115.4.1, an accessible entrance on an accessible route is practical when:

A. There is an elevator connecting the parking area with the dwelling units on a ground floor. (In this case, those dwelling units on the ground floor served by an elevator, and at least one of each type of public and common use areas, would be subject to these guidelines.) However:

1. Where a building elevator is provided only as a means of creating an accessible route to dwelling units on a ground floor, the building is not considered an elevator building for purposes of these guidelines; hence, only the ground floor dwelling units would be covered.

2. If the building elevator is provided as a means of access to dwelling units other than dwelling units on a ground floor, then the building is an elevator building which is a cov-

ered multifamily dwelling, and the elevator in that building must provide accessibility to all dwelling units in the building, regardless of the slope of the natural terrain; or

B. An elevated walkway is planned between a building entrance and a vehicular or pedestrian arrival point and the planned walkway has a slope no greater than 10 percent.

[Statutory Authority: RCW 19.27.031 and 19.27.074. 98-02-054, § 51-40-93115, filed 1/6/98, effective 7/1/98.]

WAC 51-40-93116 Section 93116.

THIS APPENDIX IS FOR REFERENCE ONLY. IT IS NOT THE RESPONSIBILITY OF THE BUILDING OFFICIAL TO ENFORCE IT.

APPENDIX CHAPTER 11 DIVISION II AMERICANS WITH DISABILITIES ACT GUIDELINES FOR READILY ACHIEVABLE BARRIER REMOVAL

93116.1 Purpose. The purpose of this division is to provide the United States Department of Justice, Americans with Disabilities Act Guidelines for readily achievable barrier removal in existing buildings.

93116.2 Scope.

93116.2.1 General. The provisions of this division may be used as a guideline for the removal of readily achievable barriers to accessibility in existing buildings, as required by the Americans with Disabilities Act of 1990.

93116.2.2 Applicability of other provisions. Except as specifically allowed by this division, all buildings and portions thereof shall meet all applicable provisions of this code.

93116.3 Definitions. For the purpose of this division, certain terms are defined as follows:

COMMERCE is travel, trade, traffic, commerce, transportation, or communication—

1. Among the several States;
2. Between any foreign country or any territory or possession and any State; or
3. Between points in the same State but through another State or foreign country.

COMMERCIAL FACILITIES are facilities—

1. Whose operations will affect commerce;
2. That are intended for nonresidential use by a private entity; and
3. That are not—
 - 3.1. Facilities that are covered or expressly exempted from coverage under the Fair Housing Act of 1968, as amended (42 U.S.C. 3601-3631);
 - 3.2. Aircraft; or
 - 3.3. Railroad locomotives, railroad freight cars, railroad cabooses, commuter or intercity passenger rail cars (including coaches, dining cars, sleeping cars, lounge cars, and food service cars), any other railroad cars described in Section 242 of the American's with Disabilities Act or covered under title II of the American's with Disabilities Act, or railroad rights-

of-way. For purposes of this definition, "rail" and "railroad" have the meaning given the term "railroad" in Section 202(e) of the Federal Railroad Safety Act of 1970 (46 U.S.C. 431 (e)).

PLACE OF PUBLIC ACCOMMODATION is a facility, operated by a private entity, whose operations affect commerce and fall within at least one of the following categories—

1. An inn, hotel, motel, or other place of lodging, except for an establishment located within a building that contains not more than five rooms for rent or hire and that is actually occupied by the proprietor of the establishment as the residence of the proprietor;
2. A restaurant, bar, or other establishment serving food or drink;
3. A motion picture house, theater, concert hall, stadium, or other place of exhibition or entertainment;
4. An auditorium, convention center, lecture hall, or other place of public gathering;
5. A bakery, grocery store, clothing store, hardware store, shopping center, or other sales or rental establishment;
6. A laundromat, dry-cleaner, bank, barber shop, beauty shop, travel service, shoe repair service, funeral parlor, gas station, office of an accountant or lawyer, pharmacy, insurance office, professional office of a health care provider, hospital, or other service establishment;
7. A terminal, depot, or other station used for specified public transportation;
8. A museum, library, gallery, or other place of public display or collection;
9. A park, zoo, amusement park, or other place of recreation;
10. A nursery, elementary, secondary, undergraduate, or postgraduate private school, or other place of education;
11. A day care center, senior citizen center, homeless shelter, food bank, adoption agency, or other social service center establishment; and
12. A gymnasium, health spa, bowling alley, golf course, or other place of exercise or recreation.

PRIVATE ENTITY is a person or entity other than a public entity.

PUBLIC ACCOMMODATION is a private entity that owns, leases (or leases to), or operates a place of public accommodation.

PUBLIC ENTITY is—

1. Any State or local government;
2. Any department, agency, special purpose district, or other instrumentality of a State or States or local government; and
3. The National Railroad Passenger Corporation, and any commuter authority (as defined in Section 103(8) of the Rail Passenger Service Act).

READILY ACHIEVABLE is easily accomplishable and able to be carried out without much difficulty or expense. In determining whether an action is readily achievable, factors to be considered include—

1. The nature and cost of the action needed under this part;

2. The overall financial resources of the site or sites involved in the action; the number of persons employed at the site; the effect on expenses and resources, or the impact otherwise of the action upon the operation of the site;

3. The overall financial resources of any parent corporation or entity; the overall size of the parent corporation or entity with respect to the number of its employees; the number, type, and location of its facilities;

4. The type of operation or operations of the parent corporation or entity, including the composition, structure, and functions of the work force of the parent corporation or entity; and

5. The geographic separateness, and the administrative or fiscal relationship of the site or sites in question to the parent corporation or entity.

93116.4 Removal of Barriers. A public accommodation shall remove architectural barriers in existing facilities, including communication barriers that are structural in nature, where such removal is readily achievable, i.e., easily accomplishable and able to be carried out without much difficulty or expense.

93116.5 Examples. Examples of steps to remove barriers include, but are not limited to, the following actions:

1. Installing ramps;
2. Making curb cuts in sidewalks and entrances;
3. Lowering shelves;
4. Rearranging tables, chairs, vending machines, display racks, and other furniture;
5. Lowering telephones;
6. Adding raised letter markings on elevator control buttons;
7. Installing flashing alarm lights;
8. Widening doors;
9. Installing offset hinges to widen doorways;
10. Eliminating a turnstile or providing an alternative accessible path;
11. Installing accessible door hardware;
12. Installing grab bars in toilet stalls;
13. Rearranging toilet partitions to increase maneuvering space;
14. Insulating lavatory pipes;
15. Installing a raised toilet seat;
16. Installing a full-length bathroom mirror;
17. Lowering the paper towel dispenser in a bathroom;
18. Creating a designated accessible parking space;
19. Installing an accessible paper cup dispenser at an existing inaccessible water fountain;
20. Removing high pile, low density carpeting; or
21. Modifying vehicle hand controls.

93116.6 Priorities. A public accommodation shall take measures to comply with the barrier removal requirements of this section in accordance with the following order of priorities:

1. First, a public accommodation shall take measures to provide access to a place of public accommodation from public sidewalks, parking, or public transportation. These measures include, for example, installing an entrance ramp, widening entrances, and providing accessible parking spaces.

2. Second, a public accommodation shall take measures to provide access to those areas of a place of public accommodation where goods and services are made available to the public. These measures include, for example, adjusting the layout of display racks, rearranging tables, widening doors, and installing ramps.

3. Third, a public accommodation shall take measures to provide access to restroom facilities in places of public accommodation where restroom facilities are used by the public on more than an incidental basis. These measures include, for example, removal of obstructing furniture or vending machines, widening of doors, installations of ramps, providing accessible signage, widening of toilet stalls, and installations of grab bars.

4. Fourth, a public accommodation shall take any other measures necessary to provide access to the goods, services, facilities, privileges, advantages, or accommodations of a place of public accommodation.

93116.7 Relationship to Alterations Requirements of Chapter 11, Part III of this Code. Measures taken solely to comply with the barrier removal requirements of this section are not required to conform to the requirements for alterations in Chapter 11, Part III of this code. These measures include, for example, installing a ramp with a steeper slope or widening a doorway to a narrower width than that required by Chapter 11, Part III of this code. No measure shall be taken, however, that poses a significant risk to the health or safety of individuals with disabilities or others. Barrier removal is required to conform to the Americans with Disabilities Act requirements for existing buildings.

93116.8 Portable Ramps. Portable ramps should be used to comply with this division only when installation of a permanent ramp is not readily achievable. In order to avoid any significant risk to the health or safety of individuals with disabilities or others in using portable ramps, due consideration shall be given to safety features such as nonslip surfaces, railings, anchoring, and strength of materials.

93116.9 Interpretation of Readily Achievable. The rearrangement of temporary or movable structures, such as furniture, equipment, and display racks is not readily achievable to the extent that it results in a significant loss of selling or serving space.

93116.10 Alternatives to Barrier Removal.

93116.10.1 General. Where a public accommodation can demonstrate that barrier removal is not readily achievable, a public accommodation shall not fail to make its goods and services, facilities, privileges, advantages, or accommodations available through alternative methods, if those methods are readily achievable.

93116.10.2 Examples. Examples of alternatives to barrier removal include, but are not limited to, the following actions:

1. Providing curb service or home delivery;
2. Retrieving merchandise from inaccessible shelves or racks;
3. Relocating activities to accessible locations;

4. Providing refueling service at inaccessible self-service gas stations.

93116.11 Personal Devices and Services. This section does not require a public accommodation to provide its customers, clients, or participants with personal devices, such as wheelchairs, or services of a personal nature including assistance in eating, toileting, or dressing.

93116.12 Multiscreen Cinemas. If it is not readily achievable to remove barriers to provide access by persons with mobility impairments to all of the theaters of a multiscreen cinema, the cinema shall establish a film rotation schedule that provides reasonable access for individuals who use wheelchairs to all films. Reasonable notice shall be provided to the public as to the location and time of accessible showings.

93116.13 Readily Achievable and Undue Burden: Factors to be Considered. In determining whether an action is readily achievable or would result in an undue burden, factors to be considered include:

1. The nature and cost of the action needed under this part;
2. The overall financial resources of the site or sites involved in the action; the number of persons employed at the site; the effect on expenses and resources, or the impact otherwise of the action upon the operation of the site;
3. The overall financial resources of any parent corporation or entity; the overall size of the parent corporation or entity with respects to the number of its employees; the number, type, and location of its facilities;
4. The type of operation or operations of the parent corporation or entity, including the composition, structure, and functions of the work force of the parent corporation or entity; and
5. The geographic separateness, and the administrative or fiscal relationship of the site or sites in question to the parent corporation or entity.

93116.14 Accessible or Special Goods.

93116.14.1 This part does not require a public accommodation to alter its inventory to include accessible or special goods that are designed for, or facilitate use by, individuals with disabilities.

93116.14.2 A public accommodation shall order accessible or special goods at the request of an individual with disabilities, if, in the normal course of its operation, it makes special orders on request for unstocked goods, and if the accessible or special goods can be obtained from a supplier with whom the public accommodation customarily does business.

93116.14.3 Examples of accessible or special goods include items such as Braille versions of books, books on audio cassettes, closed-captioned video tapes, special sizes or lines of clothing, and special foods to meet particular dietary needs.

93116.15 Seating in Assembly Areas. To the extent that it is readily achievable, a public accommodation shall:

1. Provide a reasonable number of wheelchair seating spaces in assembly areas; and,
2. Locate the wheelchair seating spaces so that they:
 - 2.1. Are dispersed throughout the seating area;
 - 2.2. Provide lines of sight comparable to those in all viewing areas;
 - 2.3. Adjoin an accessible route of travel that also serves as a means of egress in case of emergency; and,
 - 2.4. Permit individuals who use wheelchairs to sit with family members or other companions.

EXCEPTION: If removal of seats is not readily achievable, a public accommodation shall provide a portable chair or other means to permit a family member or other companion to sit with an individual who uses a wheelchair.

[Statutory Authority: RCW 19.27.031 and 19.27.074. 98-02-054, § 51-40-93116, filed 1/6/98, effective 7/1/98.]

WAC 51-40-93117 Section 93117.

THIS APPENDIX IS FOR REFERENCE ONLY. IT IS NOT THE RESPONSIBILITY OF THE BUILDING OFFICIAL TO ENFORCE IT.

**APPENDIX CHAPTER 11
DIVISION III
AMERICANS WITH DISABILITIES ACT
ALTERNATE GUIDELINES FOR DETECTABLE WARNINGS**

93117.1 General. The purpose of this division is to provide additional design guidelines for construction and installation of truncated domes as required by the Americans with Disabilities Act of 1990.

93117.2 Raised Truncated Domes. Raised truncated domes shall have a diameter of 0.9 inches (23 mm) nominal, a height of 0.2 inches (5 mm) nominal and a center-to-center spacing of 2.35 (60 mm) inches nominal. Raised truncated domes shall comply with Appendix Chapter 11, Division V for visual contrast.

[Statutory Authority: RCW 19.27.031 and 19.27.074. 98-02-054, § 51-40-93117, filed 1/6/98, effective 7/1/98.]

WAC 51-40-93118 Section 93118.

**APPENDIX CHAPTER 11
DIVISION IV
AMERICANS WITH DISABILITIES ACT
ALTERNATE GUIDELINES FOR AUDIBLE
ALARMS**

93118.1 Purpose. The purpose of this division is to provide the United States Department of Justice, Americans with Disabilities Act Guidelines for audible alarms.

93118.2 Audible Alarms. Audible alarms shall exceed the prevailing equivalent sound level in the room or space by at least 15 decibels, or shall exceed any maximum sound level with a duration of 30 seconds by 5 decibels, whichever is louder. Sound levels for alarm signals shall not exceed 120 decibels.

[Statutory Authority: RCW 19.27.031 and 19.27.074. 98-02-054, § 51-40-93118, filed 1/6/98, effective 7/1/98.]

[Title 51 WAC—p. 198]

WAC 51-40-93119 Section 93119.

THIS APPENDIX IS FOR REFERENCE ONLY. IT IS NOT THE RESPONSIBILITY OF THE BUILDING OFFICIAL TO ENFORCE IT.

**APPENDIX CHAPTER 11
DIVISION V
AMERICANS WITH DISABILITIES ACT
ALTERNATE GUIDELINES FOR VISUAL CONTRAST**

93119.1 Purpose. The purpose of this division is to provide the United States Department of Justice, Americans with Disabilities Act.

93119.2 Guidelines for Visual Contrast.

93119.2.1 Raised truncated domes. Raised truncated domes used as detectable warnings shall contrast visually by 70 percent with adjoining surfaces. Contrast in percent shall be determined as follows:

$$\text{Contrast} = [(B^1 - B^2)/B^1] \times 100$$

Where: B^1 = light reflectance value (LRV) of the lighter area;

and,

B^2 = light reflectance value (LRV) of the darker area.

The material used to provide contrast shall be an integral part of the walking surface.

93119.2.2 Signage. The characters and background of signs shall be eggshell (11 to 19 degree gloss on 60 degree glossimeter). Characters shall be light on a dark background (or dark on a light background) and contrast with their background by at least 70 percent. Contrast in percent shall be determined as follows:

$$\text{Contrast} = [(B^1 - B^2)/B^1] \times 100$$

Where: B^1 = light reflectance value (LRV) of the lighter area;

and,

B^2 = light reflectance value (LRV) of the darker area.

[Statutory Authority: RCW 19.27.031 and 19.27.074. 98-02-054, § 51-40-93119, filed 1/6/98, effective 7/1/98.]

Reviser's note: The brackets and enclosed material in the text of the above section occurred in the copy filed by the agency.

WAC 51-40-93120 Section 93120.

THIS APPENDIX IS FOR REFERENCE ONLY. IT IS NOT THE RESPONSIBILITY OF THE BUILDING OFFICIAL TO ENFORCE IT.

**APPENDIX CHAPTER 11
DIVISION VI
AMERICANS WITH DISABILITIES ACT
GUIDELINES FOR AUTOMATED TELLER
MACHINES**

93120.1 Purpose. The purpose of this division is to provide the United States Architectural and Transportation Barriers Compliance Board Americans with Disabilities Act Guidelines for automated teller machines.

93120.2 Accessible Buildings: Automated Teller Machines. Where automated teller machines are provided, each machine shall comply with the requirements below except where two or more machines are provided at a location, then only one must comply.

EXCEPTION: Drive-up-only automated teller machines are not required to comply with 93120.4 and 93120.5.

93120.3 General. Each automated teller machine required to be accessible by 93120.2 shall be on an accessible route and shall comply with the provisions of this section.

93120.4 Clear Floor Space. The automated teller machine shall be located so that clear floor space complying with 1106.2.4.1, 1106.2.4.2, 1106.2.4.3 and 1106.2.4.4 is provided to allow a person using a wheelchair to make a forward approach, a parallel approach, or both, to the machine.

93120.5 Reach Ranges.

1. Forward Approach Only. If only a forward approach is possible, operable parts of all controls shall be placed within the forward reach range specified in 1106.2.4.5.

2. Parallel Approach Only. If only a parallel approach is possible, operable parts of controls shall be placed as follows:

2.1. Reach Depth Not More Than 10 inches (255 mm). Where the reach depth to the operable parts of all controls as measured from the vertical plane perpendicular to the edge of the unobstructed clear space at the farthest protrusion of the automated teller machine or surround is not more than 10 inches (255 mm), the maximum height above the finished floor or grade shall be 54 inches (1370 mm).

2.2. Reach Depth More Than 10 inches (255 mm). Where the reach depth to the operable parts of any control as measured from the vertical plane perpendicular to the edge of the unobstructed clear floor space at the farthest protrusion of the automated teller machine or surround is more than 10 inches (255 mm), the maximum height above the finished floor or grade shall be as follows:

Reach Depth		Maximum Height	
inches	mm	inches	mm
10	255	54	1370
11	280	53 1/2	1360
12	305	53	1345
13	330	52 1/2	1335
14	355	51 1/2	1310
15	380	51	1295
16	405	50 1/2	1285
17	430	50	1270
18	455	49 1/2	1255
19	485	49	1245
20	510	48 1/2	1230
21	535	47 1/2	1205
22	560	47	1195
23	585	46 1/2	1180
24	610	46	1170

3. Forward and Parallel Approach. If both a forward and parallel approach are possible, operable parts of controls shall be placed within at least one of the reach ranges in paragraphs (1) or (2) of this section.

4. Bins. Where bins are provided for envelopes, waste paper, or other purposes, at least one of each type provided shall comply with the applicable reach ranges in paragraph (1), (2), or (3) of this section.

EXCEPTION: Where a function can be performed in a substantially equivalent manner by using an alternate control, only one of the controls needed to perform that function is required to comply with this section. If the controls are identified by tactile markings, such markings shall be provided on both controls.

93120.6 Controls. Controls for user activation shall comply with 1106.3.

93120.7 Equipment for Persons with Vision Impairments. Instructions and all information for use shall be made accessible to and independently usable by persons with vision impairments.

[Statutory Authority: RCW 19.27.031 and 19.27.074. 98-02-054, § 51-40-93120, filed 1/6/98, effective 7/1/98.]

**Chapter 51-42 WAC
STATE BUILDING CODE ADOPTION AND
AMENDMENT
OF THE 1997 EDITION OF THE UNIFORM
MECHANICAL CODE**

WAC	
51-42-001	Authority.
51-42-002	Purpose.
51-42-003	Uniform Mechanical Code.
51-42-004	Conflict between Uniform Mechanical Code and State Energy Code chapter 51-11 WAC.
51-42-005	Conflict between Uniform Mechanical Code and State Ventilation and Indoor Air Quality Code chapter 51-13 WAC.
51-42-007	Exceptions.
51-42-008	Implementation.
51-42-0200	Chapter 2—Definitions.
51-42-0223	Section 223—U.
51-42-0303	Section 303—Installation.
51-42-0405	Section 405—Direct gas-fired make-up air systems.
51-42-0504	Environmental air ducts.
51-42-0600	Chapter 6—Duct systems.
51-42-0601	Scope.
51-42-0605	Dampers in duct systems.
51-42-0901	Vented decorative appliances, decorative gas appliances for installation in solid-fuel-burning fireplaces, gas-fired log lighters, unvented decorative gas logs and decorative fireplaces.
51-42-1000	Chapter 10—Boiler/water heaters.
51-42-1002	General.
51-42-1004	Safety devices.
51-42-1005	Steam and hot-water boilers.
51-42-1100	Chapter 11—Refrigeration.
51-42-1101	General.
51-42-1102	System requirements.
51-42-1103	Refrigeration system classification.
51-42-1104	Refrigerant classification and system requirements.
51-42-1105	Machinery room, general requirements.
51-42-1106	Machinery room, special requirements.
51-42-1107	Refrigerant piping.
51-42-1108	Field test.
51-42-1109	Refrigerant piping, containers and valves.
51-42-1110	Erection of refrigerant piping.
51-42-1111	Refrigerant control valves.
51-42-1112	Pressure-limiting devices.
51-42-1113	Pressure-relief devices.
51-42-1114	Pressure-relief device settings.
51-42-1115	Marking of pressure-relief devices.

51-42-1116	Over-pressure protection.
51-42-1117	Discharge piping.
51-42-1118	Special discharge requirements.
51-42-1119	Ammonia discharge.
51-42-1120	Detection and alarm systems.
51-42-1121	Equipment identification.
51-42-1122	Testing of refrigeration equipment.
51-42-1123	Maintenance and operation.
51-42-1124	Storage of refrigerants and refrigerant oils.
51-42-1126	Tables not adopted.
51-42-1301	Section 1301—General.
51-42-1311	Material for gas piping.
51-42-1312	Installation of gas piping.
51-42-1401	Oil-burning appliances.

WAC 51-42-001 Authority. These rules are adopted under the authority of chapter 19.27 RCW.

[Statutory Authority: RCW 19.27.031 and 19.27.074. 98-02-056, § 51-42-001, filed 1/6/98, effective 7/1/98.]

WAC 51-42-002 Purpose. The purpose of these rules is to implement the provisions of chapter 19.27 RCW, which provides that the State Building Code council shall maintain the State Building Code in a status which is consistent with the purpose as set forth in RCW 19.27.020. In maintaining the codes the council shall regularly review updated versions of the codes adopted under the act, and other pertinent information, and shall amend the codes as deemed appropriate by the council.

[Statutory Authority: RCW 19.27.031 and 19.27.074. 98-02-056, § 51-42-002, filed 1/6/98, effective 7/1/98.]

WAC 51-42-003 Uniform Mechanical Code. The 1997 edition of the Uniform Mechanical Code published by the International Conference of Building Officials is hereby adopted by reference with the exceptions noted in this chapter of the Washington Administrative Code.

[Statutory Authority: RCW 19.27.031 and 19.27.074. 98-02-056, § 51-42-003, filed 1/6/98, effective 7/1/98.]

WAC 51-42-004 Conflict between Uniform Mechanical Code and State Energy Code chapter 51-11 WAC. In the case of conflict between the duct sealing or insulation requirements of Section 601 or Section 604 of this code and the duct sealing or insulation requirements of chapter 51-11 WAC, the Washington State Energy Code, or where applicable, a local jurisdiction's energy code, the provisions of such energy codes shall govern.

[Statutory Authority: RCW 19.27.031 and 19.27.074. 98-02-056, § 51-42-004, filed 1/6/98, effective 7/1/98.]

WAC 51-42-005 Conflict between Uniform Mechanical Code and State Ventilation and Indoor Air Quality Code chapter 51-13 WAC. In the case of conflict between the Group R ventilation requirements of this code and the Group R ventilation requirements of chapter 51-13 WAC, the Washington State Ventilation and Indoor Air Quality Code, the provisions of the Ventilation and Indoor Air Quality Code shall govern.

[Statutory Authority: RCW 19.27.031 and 19.27.074. 98-02-056, § 51-42-005, filed 1/6/98, effective 7/1/98.]

[Title 51 WAC—p. 200]

WAC 51-42-007 Exceptions. The exceptions and amendments to the Uniform Mechanical Code contained in the provisions of chapter 19.27 RCW shall apply in case of conflict with any of the provisions of these rules.

The provisions of this code do not apply to temporary growing structures used solely for the commercial production of horticultural plants including ornamental plants, flowers, vegetables, and fruits. "Temporary growing structure" means a structure that has the sides and roof covered with polyethylene, polyvinyl, or similar flexible synthetic material and is used to provide plants with either frost protection or increased heat retention. A temporary growing structure is not considered a building for purposes of this code.

The provisions of this code do not apply to the construction, alteration, or repair of temporary worker housing except as provided by rule adopted under chapter 70.114A RCW or chapter 37, Laws of 1998 (SB 6168). "Temporary worker housing" means a place, area, or piece of land where sleeping places or housing sites are provided by an employer for his or her employees or by another person, including a temporary worker housing operator, who is providing such accommodations for employees, for temporary, seasonal occupancy, and includes "labor camps" under RCW 70.54.110.

[Statutory Authority: RCW 19.27.031 and 19.27.074. 98-24-078, § 51-42-007, filed 12/1/98, effective 7/1/99; 98-02-056, § 51-42-007, filed 1/6/98, effective 7/1/98.]

WAC 51-42-008 Implementation. The Uniform Mechanical Code adopted by chapter 51-42 WAC shall become effective in all counties and cities of this state on July 1, 1998.

[Statutory Authority: RCW 19.27.031 and 19.27.074. 98-02-056, § 51-42-008, filed 1/6/98, effective 7/1/98.]

WAC 51-42-0200 Chapter 2—Definitions.

[Statutory Authority: RCW 19.27.031 and 19.27.074. 98-02-056, § 51-42-0200, filed 1/6/98, effective 7/1/98.]

WAC 51-42-0223 Section 223—U. UNUSUALLY TIGHT CONSTRUCTION is construction where:

1. Walls and ceilings exposed to the outside atmosphere have a continuous water vapor retarder with a rating of one perm or less with any openings gasketed or sealed, and
2. Weatherstripping on openable windows and doors, and

3. Caulking or sealants are applied to areas such as joints around window and door frames, between sole plates and floors, between wall-ceiling joints, between wall panels and at penetrations for plumbing, electrical, and gas lines and at other openings, or

4. Buildings built in compliance with the 1986 or later editions of the Washington State Energy Code chapter 51-11 WAC, Northwest Energy Code, or Super Good Cents weatherization standards or equivalent.

[Statutory Authority: RCW 19.27.031 and 19.27.074. 98-02-056, § 51-42-0223, filed 1/6/98, effective 7/1/98.]

WAC 51-42-0303 Section 303—Installation.

303.1.1 Prohibited installations. No unvented or direct fired fuel-burning equipment shall be installed or used to provide comfort heating within any occupancy group other than Group F, S or U.

EXCEPTIONS:

1. Direct gas-fired makeup air heaters may be installed in accordance with Section 909.
2. Approved, unvented portable oil-fueled heaters may be used as a supplemental heat source in any Group B, F-2, M, R, or U Occupancy provided that such heaters shall not be located in any sleeping room or bathroom, and shall comply with RCW 19.27A.080, 19.27A.090, 19.27A.100, 19.27A.110, and 19.27A.120.

[Statutory Authority: RCW 19.27.031 and 19.27.074. 98-02-056, § 51-42-0303, filed 1/6/98, effective 7/1/98.]

WAC 51-42-0405 Section 405—Direct gas-fired make-up air systems.

405.1 General. Direct gas-fired make-up air heaters shall not be installed for comfort heating in other than Group F, S, or U Occupancies.

EXCEPTION: Direct gas-fired make-up air heaters may be installed in accordance with Section 909.

[Statutory Authority: RCW 19.27.031, 19.27.074. 01-02-098, § 51-42-0405, filed 1/3/01, effective 7/1/01.]

WAC 51-42-0504 Environmental air ducts.

504.3.1 Moisture exhaust ducts. Moisture exhaust ducts for domestic clothes dryers shall terminate on the outside of the building and shall be equipped with a back-draft damper. Screens shall not be installed at the duct termination. Ducts for exhausting clothes dryers shall not be connected or installed with sheet metal screws or other fasteners which will obstruct the flow. Clothes dryer moisture exhaust ducts shall not be connected to a gas vent connector, gas vent or chimney. Clothes dryer moisture exhaust ducts shall not extend into or through ducts or plenums. Clothes dryer exhaust ducts shall be protected by a steel plate or clip not less than 1/16 inch (1.59 mm) in thickness and of sufficient width to fully protect the duct. Plates or clips shall be placed on the finish face of all framing members which the clothes dryer exhaust duct passes through when there is less than one-and-one-quarter inch (1 1/4") (32 mm) of framing material between the duct and the finish face. Plates or clips shall also be placed where nails or screws from finish or other work are likely to penetrate the clothes dryer exhaust duct.

[Statutory Authority: RCW 19.27.031 and 19.27.074. 98-02-056, § 51-42-0504, filed 1/6/98, effective 7/1/98.]

WAC 51-42-0600 Chapter 6—Duct systems.

[Statutory Authority: RCW 19.27.031 and 19.27.074. 98-02-056, § 51-42-0600, filed 1/6/98, effective 7/1/98.]

WAC 51-42-0601 Scope.

601.1 Material. Supply air, return air, and outside air for heating, cooling, or evaporative cooling systems shall be conducted through duct systems constructed of metal as set forth in Tables 6-A, 6-B and 6-C; metal ducts complying with the

(2003 Ed.)

U.M.C. Standard 6-1 with prior approval; or factory-made air ducts complying with UL 181. Ducts, plenums, and fittings may be constructed of concrete, clay, ceramics, or other approved nonmetallic materials when installed in the ground or in a concrete slab, provided the joints are tightly sealed.

601.1.1 Use of corridor as plenum. Corridors shall not be used to convey air to or from rooms if the corridor is required to be of fire-resistive construction by Section 1005 of the Building Code.

EXCEPTIONS:

1. Where such air is part of an engineered smoke control system.
2. Corridors conforming to Section 1007.5 of the Uniform Building Code in Group I Occupancies.
3. Corridors serving residential occupancies may be supplied without specific mechanical exhaust subject to the following:
 - 3.1 The supply air is 100% outside air, and
 - 3.2 The units served by the corridor have conforming ventilation independent of the air supplied to the corridor, and
 - 3.3 For other than high-rise buildings, the supply fan will automatically shut off upon activation of corridor smoke detectors which shall be spaced at no more than 30 feet (9144 mm) on center along the corridor, or
 - 3.4 For high-rise buildings, corridor smoke detector activation will close required smoke/fire dampers at the supply inlet to the corridor at the floor receiving the alarm.

601.3 Contamination Prevention. Exhaust ducts under positive pressure and venting systems shall not extend into or pass through ducts or plenums. For appliance vents and chimneys, see Chapter 8.

EXCEPTION: Exhaust ducts conveying environmental air may pass through a duct or plenum provided that:

1. The duct is maintained under sufficient negative pressure to prevent leakage of the exhaust air to the surrounding duct or plenum; or
2. If maintained under a positive pressure with respect to the surrounding duct or plenum, the exhaust duct will be sealed to prevent leakage; or
3. The surrounding air stream is an exhaust air stream not intended for recirculation to the building and cross contamination of the two air streams will not create a hazardous condition.

[Statutory Authority: RCW 19.27.031 and 19.27.074. 98-02-056, § 51-42-0601, filed 1/6/98, effective 7/1/98.]

WAC 51-42-0605 Dampers in duct systems.

605.2 Fire Dampers. Fire dampers complying with recognized standards in chapter 16, Part III, shall be installed in accordance with approved manufacturer's instructions when required by chapter 7 of the Building Code. Fire dampers shall have been tested for closure under airflow conditions and shall be labeled for both maximum airflow permitted and direction of flow. When more than one damper is installed at a point in a single air path, the entire airflow shall be assumed to be passing through the smallest damper area. Fire dampers shall be labeled by an approved agency. Only fire dampers labeled for use in dynamic systems shall be installed in heating, ventilation and air-conditioning systems which are intended to operate with fans "on" during a fire; see U.B.C. Section 713.12.

EXCEPTION: Fire dampers need not be installed in air ducts passing through the wall, floor, or ceiling separating a Group R, Division 3 Occupancy from a Group U Occupancy, provided such ducts within the Group U Occupancy

are constructed of steel having a thickness not less than 0.019 inch (0.48 mm) (No. 26 galvanized sheet gage) and have no openings into the Group U Occupancy.

Ductwork shall be connected to damper sleeves or assemblies in such a way that collapse of the ductwork will not dislodge the damper or impair its proper operation.

[Statutory Authority: RCW 19.27.031 and 19.27.074. 98-02-056, § 51-42-0605, filed 1/6/98, effective 7/1/98.]

WAC 51-42-0901 Vented decorative appliances, decorative gas appliances for installation in solid-fuel-burning fireplaces, gas-fired log lighters, unvented decorative gas logs and decorative fireplaces.

901.4 Unvented decorative gas logs and decorative fireplaces. Approved, unvented decorative gas logs and decorative fireplaces may be installed, used, maintained, and permitted to exist in any Group I or R Occupancy, except bathrooms and bedrooms. An unvented decorative gas log is a listed natural or liquefied petroleum gas burning log with an open flame consisting of a metal frame or base supporting simulated logs which is designed so that its primary function lies in the aesthetic effect of the logs and flame. An unvented decorative fireplace is a listed unvented gas log permanently installed in a freestanding enclosure or zero clearance enclosure designed and approved for installation in walls or other building structures. Unvented decorative gas logs and fireplaces shall:

1. Be equipped with an approved oxygen-depletion sensor;
2. Be listed;
3. Not be installed in any room which does not have an alternative primary source of heat;
4. Have free air volume of at least 50 cubic feet (1.4 m³) for each 1,000 Btus (2.2 mm²/W) of thermal output; and
5. Be permanently installed.

[Statutory Authority: RCW 19.27.031 and 19.27.074. 98-02-056, § 51-42-0901, filed 1/6/98, effective 7/1/98.]

WAC 51-42-1000 Chapter 10—Boiler/water heaters.

[Statutory Authority: RCW 19.27.031 and 19.27.074. 98-02-056, § 51-42-1000, filed 1/6/98, effective 7/1/98.]

WAC 51-42-1002 General.

1002.2 Water Heater Used for Space Heating. The potability of the domestic water system shall be maintained when a water heater is used as a part of a space heating system.

Water heaters used for space heating only are prohibited.

[Statutory Authority: RCW 19.27.031 and 19.27.074. 98-02-056, § 51-42-1002, filed 1/6/98, effective 7/1/98.]

[Title 51 WAC—p. 202]

WAC 51-42-1004 Safety devices. This section is not adopted.

For safety devices and installation of water heaters, see the Plumbing Code.

[Statutory Authority: RCW 19.27.031 and 19.27.074. 98-02-056, § 51-42-1004, filed 1/6/98, effective 7/1/98.]

WAC 51-42-1005 Steam and hot-water boilers. Part II—Steam and Hot-water Boilers, Sections 1005 through 1029 and Table 10-A through Table 10-C, are not adopted.

Boilers and Unfired Pressure Vessels are regulated by chapter 70.79 RCW and chapter 296-104 WAC.

[Statutory Authority: RCW 19.27.031 and 19.27.074. 98-02-056, § 51-42-1005, filed 1/6/98, effective 7/1/98.]

WAC 51-42-1100 Chapter 11—Refrigeration.

[Statutory Authority: RCW 19.27.031 and 19.27.074. 98-02-056, § 51-42-1100, filed 1/6/98, effective 7/1/98.]

WAC 51-42-1101 General.

1101.1 Scope. This chapter shall govern the design, installation, construction and repair of refrigeration systems that vaporize and liquefy a fluid during the refrigerating cycle. Refrigerant piping design and installation, including pressure vessels and pressure relief devices, shall conform to this code. Permanently installed refrigerant storage systems and other components shall be considered as part of the refrigeration system to which they are attached.

1101.2 Factory-built equipment. Listed and labeled self-contained, factory-built equipment shall be tested in accordance with UL 207, 303, 412, 465, 471 or 1995.

1101.3 Protection. Any portion of a refrigeration system that is subject to physical damage shall be protected in an approved manner.

1101.4 Water connection. Water supply and discharge connections associated with refrigeration systems shall be made in accordance with this code and the plumbing code.

1101.5 Gas connection. Gas fuel devices and equipment used with refrigeration systems shall be installed in accordance with this code.

1101.6 General. Refrigeration systems shall comply with the requirements of this code and, except as modified by this code, ASHRAE 15-1994. Ammonia-refrigerating systems shall comply with this code and, except as modified by this code, ASHRAE 15-1994 and IIAR 2-1992.

[Statutory Authority: RCW 19.27.031 and 19.27.074. 98-02-056, § 51-42-1101, filed 1/6/98, effective 7/1/98.]

WAC 51-42-1102 System requirements.

1102.1 General. The system classification, allowable refrigerants, the maximum quantity, enclosure requirements, location limitations and field pressure test requirements, shall be determined as follows:

1. Determine the refrigeration system's classification in accordance with Section 1103.
2. Determine the refrigerant classification in accordance with Table 1104.1.
3. Determine the maximum allowable quantity of refrigerant in accordance with Table 1104.2(1), based on type of refrigerant, system classification and occupancy.
4. Determine the system enclosure requirements in accordance with Table 1104.2(1).
5. Refrigeration equipment location and installation shall be subject to the limitations of Chapter 3.
6. Nonfactory-tested, field-erected equipment shall be pressure tested in accordance with Section 1108.

1102.2 Refrigerants. Refrigerants not identified in Table 1104.1 shall be approved before use. Refrigerants (including refrigerant blends) with different designations in ASHRAE 34-1992, with addenda through 1995, shall not be mixed in a system.

1102.2.1 New refrigerants. Refrigerants used in new equipment shall be of a type and purity level specified or approved by the equipment manufacturer.

1102.2.2 Recovered refrigerants. Refrigerants that are recovered from refrigeration and air-conditioning systems shall not be reused in other than the system from which they were recovered and in other systems of the same owner. Recovered refrigerants shall be filtered and dried before reuse. Recovered refrigerants that show clear signs of contamination shall not be reused unless reclaimed in accordance with Section 1102.2.3.

1102.2.3 Reclaimed refrigerants. Used refrigerants shall not be reused in a different owner's equipment unless reclaimed and found to meet the purity requirements of ARI 700-1993. Contaminated refrigerants shall not be used in the

same owner's equipment or in a different owner's equipment unless reclaimed and found to meet the purity requirements of ARI 700-1993.

[Statutory Authority: RCW 19.27.031 and 19.27.074. 98-02-056, § 51-42-1102, filed 1/6/98, effective 7/1/98.]

WAC 51-42-1103 Refrigeration system classification.

1103.1 General. For the purposes of applying Tables 1104.1, 1104.2(1), and 1104.2(2), refrigeration systems shall be classified as high-probability or low-probability system based on the potential hazard resulting from a leakage of refrigerant into an occupancy-classified area other than the machinery room.

1103.2 High-probability systems. Direct systems and indirect open-spray systems shall be classified as high-probability systems.

EXCEPTION: An indirect open-spray system shall not be required to be classified as a high-probability system if the pressure of the secondary coolant is at all times (operating and standby) greater than the pressure of the refrigerant.

1103.3 Low-probability systems. Double-indirect open-spray systems, indirect closed systems and indirect-vented closed systems shall be classified as low-probability systems, provided that all refrigerant-containing piping and fittings are isolated when the quantities in Table 1104.1 are exceeded.

[Statutory Authority: RCW 19.27.031, 19.27.074. 01-02-098, § 51-42-1103, filed 1/3/01, effective 7/1/01; 98-02-056, § 51-42-1103, filed 1/6/98, effective 7/1/98.]

WAC 51-42-1104 Refrigerant classification and system requirements.

1104.1 Refrigerant classification. Refrigerants shall be classified in accordance with ASHRAE 34-1992, with addenda through 1995, as listed in Table 1104.1.

TABLE 1104.1
REFRIGERANT^a CLASSIFICATION, AMOUNT^{b,c} AND TLV-TWA^f

Refrigerant Classification	REFRIGERANT DESCRIPTION		AMOUNT OF REFRIGERANT PER OCCUPIED SPACE			TLV ^f TWA ppm
	Name or Blend	Chemical Formula	Lb per 1,000 ft ³ a	ppm	g/m ³ c	
Group A1						
R-11	Trichlorofluoromethane	CCl ₃ F	1.6	4,000	250	C1,000
R-12	Dichlorofluoromethane	CCl ₂ F ₂	12	40,000	200	1,000
R13	Chlorotrifluoromethane	CClF ₃	18	67,000	290	1,000
R-13B1	Bromotrifluoromethane	CBrF ₃	22	57,000	350	1,000
R-14	Tetrafluoromethane (Carbon Tetrafluoride)	CF ₄	15	67,000	240	1,000
R-22	Chlorodifluoromethane	CHClF ₂	9.4	42,000	150	1,000
R-113	1,1,2-trichloro-1,2,2-trifluoroethane	CCl ₂ FCClF ₂	1.9	4,000	31	1,000
R-114	1,2-dichloro-1,1,2,2-tetrafluoroethane	RCClF ₂ CClF ₂	9.4	21,000	150	1,000
R-115	Chloropentafluoroethane	CClF ₂ CF ₃	27	67,000	430	1,000
R-134a	1,1,1,2-tetrafluoroethane	CH ₂ FCF ₃	16	60,000	250	1,000
R-C318	Octafluorocyclobutane	-CF ₂ -CF ₂ -CF ₂ -CF ₂ -	35	67,000	550	1,000
R-400	R-12/R-114	CCl ₂ F ₂ /CCl ₂ FCClF ₂	Note d	Note d	Note d	1,000
R-500	R-12/152a(73.8/26.2)	CClF ₂ /CH ₃ CHF ₂	12	47,000	200	1,000
R-502	R-22/115(48.8/51.2)	CHClF ₂ /CClF ₂ CF ₃	19	65,000	300	1,000
R-503	R-23/13(40.1/59.9)	CHF ₃ /CClF ₃	15	67,000	240	1,000

R-744	Carbon Dioxide	CO ₂	5.7	50,000	91	5,000
Group A2						
R-142b	1-chloro-1,1-difluoroethane	CH ₃ CClF ₂	3.7	14,000	60	1,000
R-152a	1,1-difluoroethane	CH ₃ CHF ₂	1.2	7,000	20	1,000
Group A3 ^b						
R-170	Ethane	CH ₃ CH ₃	0.50	6,400	8.0	1,000
R-290	Propane	CH ₃ CH ₂ CH ₃	0.50	4,400	8.0	1,000
R-600	Butane	CH ₃ CH ₂ CH ₂ CH ₃	0.51	3,400	8.2	800
R-600a	2-Methyl propane (Isobutane)	CH(CH ₃) ₂ CH ₃	0.51	3,400	8.2	800
R-1150	Ethene (Ethylene)	CH ₂ = CH ₂	0.38	5,200	6.0	1,000
R-1270	Propene (Propylene)	CH ₃ CH = CH ₂	0.37	3,400	5.0	1,000
Group B1						
R-123	2,2-dichloro-1,1,1-trifluoroethane	CHCl ₂ CF ₃	0.4	1,000	6.3	30
R-764	Sulfur Dioxide	SO ₂	0.016	100	0.26	2
Group B2						
R-40	Chloromethane (methyl chloride)	CH ₃ Cl	1.3	10,000	21.0	C50
R-611	Methyl Formate	HCOOCH ₃	0.78	5,000	12.0	100
R-717	Ammonia	NH ₃	0.022	500	0.35	25
Group B3 ^b	—	—	—	—	—	—

For SI: 1 pound = 0.454 kg, 1 cubic foot = 0.0283 m³.

^a Other refrigerants shall be approved.

^b To be used only in conjunction with footnotes from Table 1104.2(1).

^c To correct for height, *H* (feet), above sea level, multiply these values by (1-2.42 x 10⁻⁶*H*). To correct for height, *h* (km), above sea level, multiply these values by (1-7.94 x 10⁻² *h*). Do not adjust volume percent or TLV-TWA (ppm) for altitude.

^d The quantity of each component shall comply with the limits set in Table 1104.1 for the pure compound and the total volume percent of all components shall not exceed 6.7 volume percent.

^e The basis of the table amounts is given as follows:

Group A1	Eighty percent of the cardiac sensitization level for R-11, R-12, R-13B1, R-22, R-113, R-114, R-134a, R-500 and R-502. One hundred percent of the IDLH for R-744. Others are limited by levels where oxygen deprivation begins to occur.
Group A2, A3	Approximately 20 percent of LFL.
Group B1	One hundred percent of IDLH for R-764, and 100 percent of the measure consistent with the IDLH for R-123.
Group B2, B3	One hundred percent of IDLH or 20 percent of LFL, whichever is lower.

^f TLV-TWA or measure consistent therewith to be used with Section 1104. The values shown for R-11 and R-40 are TLV-C (TLV-ceiling) values not to be exceeded.

^g Group A3 and B3 refrigerants as listed in Table 1104.1 shall not be used in a refrigerating system in excess of 1,000 pounds, unless approved by the code official.

1104.2 System requirements. The maximum allowable refrigerant quantities shall be in accordance with Table 1104.2(1). To use Table 1104.2(1), determine the occupancy class, refrigerant group in accordance with Table 1104.1 and type of system in accordance with Section 1103, and then locate the notes that apply.

1104.2.1 Occupancy classification. Locations of refrigerating systems are described by occupancy classifications that consider the ability of people to respond to potential exposure to refrigerant. Where equipment, other than piping, is located outside a building and within 20 feet (6096 mm) of any building opening, such equipment shall be governed by the occupancy classification of the building. Occupancy classifications shall be defined as follows:

1. Institutional occupancy is that portion of premises from which, because they are disabled, debilitated or confined, occupants cannot readily leave without the assis-

tance of others. Institutional occupancies include, among others, hospitals, nursing homes, asylums and spaces containing locked cells.

- Public assembly occupancy is that portion of premises where large numbers of people congregate and from which occupants cannot quickly vacate the space. Public assembly occupancies include, among others, auditoriums, ballrooms, classrooms, passenger depots, restaurants and theaters.
- Residential occupancy is that portion of premises that provides the occupants with complete independent living facilities, including permanent provisions for living, sleeping, eating, cooking and sanitation. Residential occupancies include, among others, dormitories, hotels, multi-unit apartments and private residences.
- Commercial occupancy is that portion of premises where people transact business, receive personal service or purchase food and other goods. Commercial occupancies include, among others, office and professional buildings, markets (but not large mercantile occupancies) and work or storage areas that do not qualify as industrial occupancies.
- Large mercantile occupancy is that portion of premises where more than 100 persons congregate on levels above or below street level to purchase personal merchandise.
- Industrial occupancy is that portion of premises that is not open to the public, where access by authorized persons is controlled, and that is used to manufacture, process or store goods such as chemicals, food, ice, meat or petroleum.
- Mixed occupancy occurs when two or more occupancies are located within the same building. When each occupancy is isolated from the rest of the building by tight walls, floors and ceilings and by self-closing doors, the requirements for each occupancy shall apply to its portion of the building. When the various occupancies are not so isolated, the occupancy having the most stringent requirements shall be the governing occupancy.

TABLE 1104.2(1)
SYSTEM APPLICATION REQUIREMENTS
(Letters in the table under "Occupancy" refer to footnotes.
Where more than one footnote exists, each footnote is a limitation on the other.)
(For system and refrigerant classifications see Section 1103 and Table 1104.1.)

REFRIGERANT GROUP	SYSTEM CLASSIFICATION	OCCUPANCY ^d		
		Institutional	Public assembly, residential, commercial and large mercantile	Industrial
A1	High	a	b	c
	Low	d	d	d
A2	High	e	e	c,f,h
	Low	g	g	g
A3	High	i	i	c,f,h
	Low	i	i	g
B1	High	a,f	b,f	c
	Low	d	d	d
B2	High	e,f	e,f	c,f,h
	Low	g	g	g
B3	High	i	i	c,f,h
	Low	i	i	g

For SI: 1 square foot = 0.0929 m², 1 pound = 0.454 kg.

- ^a The refrigerant amount is limited to 50 percent of those listed in Table 1104.1, except Footnote b applies in kitchens, laboratories and mortuaries. If any portion of a refrigerant system containing more than 1 pound of refrigerant (except R-744) is in a room with a flame-sustaining device, this device shall be provided with a hood to exhaust combustion products to the outside air. Otherwise Footnotes e and f shall be followed.
- ^b The refrigerant amount shall be limited as listed in Table 1104.1
- ^c The refrigerant amount shall be unlimited when all of the following are satisfied:
 1. The area containing machinery is separated from the areas of the building not containing machinery by tight construction with tight-fitting doors;
 2. Egress from the room is directly outdoors;
 3. The number of persons in a machinery-containing space on any floor above the first floor (ground level or deck level) is equal to or less than one person per 100 square feet of floor area or, if the number exceeds one person per 100 square feet, the machinery-containing space shall be provided with the required number of doors opening directly into approved building exits; and
 4. Detectors are located in areas where refrigerant vapor from a leak will concentrate so as to provide warning at levels not exceeding the TLV-TWA quantities given in Table 1104.1. Otherwise, the footnotes for other occupancies shall apply.

Exception: For ammonia, see Section 1106.8.
- ^d When the quantity of refrigerant in the largest system exceeds the amounts in Table 1104.1, all refrigerant-containing parts, except piping and those parts outside the building, shall be installed in a machinery room meeting the general requirement of Section 1105.

- ^e Refrigerant amounts and types of systems shall be limited as shown in Table 1104.2(2).
- ^f Applications involving air conditioning for human comfort are prohibited.
- ^g When the quantity of refrigerant in the largest system exceeds the amounts in Table 1104.1, all refrigerant-containing parts, except piping and those parts outside the building, shall be installed in a special requirements machinery room in accordance with Section 1106 with limitations on refrigerant quantities as follows:
 - 550 pounds — Institutional
 - No limit except Footnote h — Public Assembly
 - No limit except Footnote h — Residential
 - No limit except Footnote h — All other occupancies
 - No limit except Footnote h — Industrial
 - Otherwise, Footnote e applies to the amount of Group A2, A3, B2 or B3 refrigerant in the system.
- ^h When the quantity of refrigerant exceeds Table 1104.1 amounts, all refrigerant-containing parts, except piping, low-side components, condensers, and parts outside the building, shall be installed in a machinery room meeting the general requirements in Section 1105. For refrigerants of Groups A2, A3, B2 and B3:
 1. The machinery room shall also meet the special requirements of Section 1106.
 2. Except for ammonia, amounts in excess of 1,100 pounds shall be approved by the code official.
- ⁱ Use of these refrigerants is prohibited, except in laboratories in commercial occupancies. Only unit systems containing not more than 6.6 pounds of Group A3 or B3 refrigerant shall be used unless the laboratory is occupied by less than one person per 100 square feet of floor area, in which case the requirements of industrial occupancies shall apply.

TABLE 1104.2(2)
MAXIMUM PERMISSIBLE QUANTITIES OF REFRIGERANTS
[For use with footnote e of Table 1104.2(1)]

TYPE OF REFRIGERATION SYSTEM	MAXIMUM POUNDS FOR VARIOUS OCCUPANCIES			
	Institutional	Assembly	Residential	All Other Occupancies
Sealed Absorption System				
In exit access	0	0	3.3	3.3
In adjacent outdoor locations	0	0	22	22
In other than exit access	0	6.6	6.6	22
Unit Systems				
In other than exit access	0	0	6.6	22

For SI: 1 pound = 0.454 kg.

1104.3 Volume calculations. Volume calculations shall be in accordance with Sections 1104.3.1 through 1104.3.3.

1104.3.1 Unventilated spaces. Where the refrigerant-containing parts of a system are located in one or more unventilated spaces, the volume of the smallest, enclosed occupied space, other than a machinery room, shall be used to determine the permissible quantity of refrigerant in the system. Where a building consists of several stories of unpartitioned space, such as a mezzanine or an atrium, the story having the smallest occupied space shall be deemed to be the enclosed space.

1104.3.2 Ventilated spaces. Where an evaporator or condenser is located in an air duct system, the volume of the smallest occupied space or unpartitioned building story, served by the duct shall be used to determine the maximum allowable quantity of refrigerant in the system.

EXCEPTION: If airflow to any enclosed space cannot be reduced below one-quarter of its maximum, the entire space served by the air duct system shall be used to determine the maximum allowable quantity of refrigerant in the system.

1104.3.3 Plenums. Where the space above a suspended ceiling is continuous and part of the supply or return air plenum system, this space shall be included in calculating the volume of the enclosed space.

[Statutory Authority: RCW 19.27.031 and 19.27.074. 98-02-056, § 51-42-1104, filed 1/6/98, effective 7/1/98.]

Reviser's note: The brackets and enclosed material in the text of the above section occurred in the copy filed by the agency.

WAC 51-42-1105 Machinery room, general requirements.

1105.1 General. Where required by Table 1104.2(1), a machinery room shall be provided to enclose refrigeration systems located indoors. Access to the machinery room shall be restricted to authorized personnel. For rooms where occupational exposure could occur, see WAC 296-62-07515 and 296-62-3112.

1105.2 Dimensions. A machinery room shall be dimensioned so as to provide clearances required by chapter 3. There shall be clear head room of not less than 7 feet 3 inches (2210 mm) below equipment located over passageways.

1105.3 Doors. Each machinery room shall have self-closing, weather-stripped doors opening in the direction of egress travel. Doors and door openings shall comply with the requirements of the Building Code.

1105.4 Openings. Openings to other parts of the building that permit passage of escaping refrigerant to other parts of the building are prohibited. Ducts and air handlers in the machinery room that operate at a lower pressure than the room shall be sealed to prevent any refrigerant leakage from entering the airstream.

EXCEPTIONS:

1. Egress doors serving the machinery room.
2. Access doors and panels in air ducts and air-handling units, provided that such openings are gasketed and tight fitting.

1105.5 Refrigerant vapor detector. Machinery rooms shall contain a refrigerant vapor detector with an audible and visual alarm. The detector, or a sampling tube that draws air to the detector, shall be located in an area where refrigerant vapor from a leak will concentrate. The alarm shall be actuated at a value not greater than the corresponding TLV-TWA values shown in Table 1104.1. Detectors and alarms shall be placed in approved locations. Detection and alarm systems shall be powered and supervised, monitored and annunciated, and installed and maintained as required by Section 6313 of the Fire Code.

EXCEPTION: Detectors are not required for ammonia systems complying with Section 1106.8.

1105.6 Tests. Periodic tests of the detector, alarm and mechanical ventilating system shall be performed in accordance with manufacturer's specifications and as required by the code official.

1105.7 Fuel-burning equipment. Open flames that use combustion air from the machinery room shall not be installed in a machinery room.

EXCEPTIONS:

1. Matches, lighters, halide leak detectors and similar devices.
2. Where the refrigerant is carbon dioxide or water.
3. Fuel-burning equipment shall not be prohibited in the same machinery room with refrigerant-containing equipment where combustion air is ducted from outside the machinery room and sealed in such a manner as to prevent any refrigerant leakage from entering the combustion chamber, or where a refrigerant vapor detector is employed to automatically shut off the combustion process in the event of refrigerant leakage.

1105.8 Sign. A sign shall be posted on the machinery room door prohibiting access of unauthorized personnel.

1105.9 Ventilation. Machinery rooms shall be mechanically ventilated to the outdoors. Mechanical ventilation shall be capable of exhausting the minimum quantity of air both at the normal operating and emergency conditions. Multiple fans or multispeed fans shall be allowed in order to produce the emergency ventilation rate and to obtain a reduced airflow for normal ventilation. Fans providing refrigeration machinery room temperature control or automatic response to refrigerant vapor are allowed to be automatically controlled to provide intermittent ventilation as conditions require.

EXCEPTION: Where a refrigerating system is located outdoors more than 20 feet (6096 mm) from any building opening and is enclosed by a penthouse, lean-to or other open structure, natural or mechanical ventilation shall be provided. Location of the openings shall be based on the relative density of the refrigerant to air. The free-aperture cross section for the ventilation of the machinery room shall be not less than:

$$F = \sqrt{G}$$

$$\text{For SI: } F = 0.138 \sqrt{G}$$

where:

F = The free opening area in square feet (m²).

G = The mass of refrigerant in pounds (kg) in the largest system, any part of which is located in the machinery room.

1105.9.1 Discharge location. The discharge of the air shall be to the outdoors in accordance with chapter 5. Exhaust from mechanical ventilation systems shall be discharged not less than 20 feet (6096 mm) from a property line or openings into buildings.

1105.9.2 Supply air. Provisions shall be made for supply air to replace that being exhausted. Openings for supply air shall be located to avoid intake of exhaust air. Air supply and exhaust ducts to the machinery room shall serve no other area, shall be constructed in accordance with chapter 5 and shall be covered with corrosion-resistant screen of not less than 1/4 inch (6.4 mm) mesh. The supply air shall be taken from directly outside the building. Intakes shall be fitted with backdraft dampers or similar approved flow control means to prevent reverse flow.

1105.9.3 Quantity—normal ventilation. During occupied conditions the mechanical ventilation system shall exhaust the larger of the following:

1. Not less than 0.5 cfm per square foot (0.0025 m³/s • m²) of machinery room area or 20 cfm (0.009 m³/s) per person; or
2. A volume required to maintain a maximum temperature rise of 18°F (-7.8°C) based on all of the heat-producing machinery in the room.

1105.9.4 Quantity—emergency conditions. Upon actuation of the refrigerant detector required in Section 1105.5, the mechanical ventilation system shall exhaust air from the machinery room in the following quantity:

$$Q = 100 \times \sqrt{G}$$

For SI: $Q = 0.07 \times \sqrt{G}$

where:

Q = The airflow in cubic feet per minute (m³/s).

G = The design mass of refrigerant in pounds (kg) in the largest system, any part of which is located in the machinery room.

1105.10 Termination of relief devices. In the equipment room, pressure relief devices, fusible plugs and purge systems shall terminate outside of the structure at a location not less than 15 feet (4572 mm) above the adjoining grade level and not less than 20 feet (6096 mm) from any window, ventilation opening or exit.

[Statutory Authority: RCW 19.27.031, 19.27.074, 01-02-098, § 51-42-1105, filed 1/3/01, effective 7/1/01; 98-02-056, § 51-42-1105, filed 1/6/98, effective 7/1/98.]

WAC 51-42-1106 Machinery room, special requirements.

1106.1 General. Where required by Table 1104.2(1), the machinery room shall meet the requirements of this section in addition to the requirements of Section 1105.

1106.2 Elevated temperature. There shall not be an open flame-producing device or continuously operating hot surface over 800°F (427°C) permanently installed in the room.

1106.3 Construction requirements. The machinery room shall be separated from other occupied space with smoke-tight, 1-hour fire-resistance-rated construction.

1106.4 Opening protectives. Opening protection between the machinery room and other occupied spaces shall be approved, self-closing, tight-fitting fire doors with a minimum fire-resistance-rating of 3/4 hour.

1106.5 Pipe penetrations. All pipe penetrations of the interior walls, ceiling or floor of machinery rooms shall be sealed vapor tight and protected in accordance with the Building Code.

1106.6 Exterior openings. Openings in exterior walls of machinery rooms shall not be located under any exit, stairway or exit discharge.

1106.7 Egress. Means of egress shall comply with Section 1007.7 of the Building Code.

Each machinery room shall be provided with a minimum of one exit door that opens directly to the outside.

EXCEPTIONS:

1. Self-closing, tight-fitting doors opening into a vestibule leading directly outside.
2. Existing machinery rooms.

1106.8 Ammonia room ventilation. Ventilation equipment in ammonia machinery rooms shall be operated continuously.

EXCEPTIONS:

1. Machinery rooms equipped with a refrigerant vapor detector that will automatically start the ventilation system and actuate an alarm at a detection level not to exceed 1,000 ppm; or
2. Machinery rooms conforming to the Class 1, Division 2, hazardous location classification requirements of NFPA 70.

1106.9 Flammable refrigerants. Where refrigerants of Groups A2, A3, B2 and B3 are used, the machinery room shall conform to the Class 1, Division 2, hazardous location classification requirements of NFPA 70.

EXCEPTION: Ammonia machinery rooms.

1106.10 Remote controls. Remote control of the mechanical equipment located in the machinery room shall be provided at an approved location immediately outside the machinery room and adjacent to its principal entrance.

1106.10.1 Refrigeration system. A clearly identified switch of the break-glass-type shall provide off-only control of all electrically energized equipment in the machinery room, other than the refrigerant leak detectors and machinery room ventilation.

1106.10.2 Ventilation system. Mechanical ventilation systems shall have switches to control power to each fan. The switches shall be key operated or within a locked glass-covered enclosure at an approved location adjacent to and outside of the principal entrance to the machinery room. Necessary keys shall be located in a single approved location. Switches controlling fans providing intermittent or emergency ventilation shall be of the three-position, automatic/on/off type. Switches shall be labeled identifying both function and specific fan controlled. Two-colored and labeled indicator lamps responding to the differential pres-

sure created by the air flow shall be provided for each switch. One lamp shall indicate flow, the other shall indicate no flow.

1106.10.3 Emergency control box. An emergency control box shall be provided as required by IIAR 2-1992 Section 5.4. Emergency control boxes shall be designed and constructed to the standards of IIAR 2-1992 Appendix A except as modified by Section 6307 of the Fire Code.

[Statutory Authority: RCW 19.27.031 and 19.27.074. 98-02-056, § 51-42-1106, filed 1/6/98, effective 7/1/98.]

WAC 51-42-1107 Refrigerant piping.

1107.1 General. All refrigerant piping shall be installed, tested and placed in operation in accordance with this chapter.

1107.2 Pipe enclosures. Rigid or flexible metal enclosures or pipe ducts shall be provided for soft, annealed copper tubing and used for refrigerant piping erected on the premises and containing other than Group A1 or B1 refrigerants. Enclosures shall not be required for connections between condensing units and the nearest riser box(es), provided such connections do not exceed 6 feet (1829 mm) in length.

1107.3 Condensation. All refrigerating piping and fittings, brine piping and fittings that, during normal operation, will reach a surface temperature below the dew point of the surrounding air, and are located in spaces or areas where condensation will cause a safety hazard to the building occupants, structure, electrical equipment or any other equipment, shall be protected in an approved manner to prevent such damage.

1107.4 Materials for refrigerant pipe and tubing. Piping materials shall be as set forth in Sections 1107.4.1 through 1107.4.5.

1107.4.1 Steel pipe. Carbon steel pipe with a wall thickness not less than Schedule 80 shall be used for Group A2, A3, B2 or B3 refrigerant liquid lines for sizes 1 1/2 inches (38 mm) and smaller. Carbon steel pipe with a wall thickness not less than Schedule 40 shall be used for Group A1 or B1 refrigerant liquid lines 6 inches (152 mm) and smaller, Group A2, A3, B2 or B3 refrigerant liquid lines sizes 2 inches (51 mm) through 6 inches (152 mm), and all refrigerant suction and discharge lines 6 inches (152 mm) and smaller. Type F steel pipe shall not be used for refrigerant lines having an operating temperature less than -20°F (-29°C).

1107.4.2 Copper and brass pipe. Standard iron-pipe size, copper and red brass (not less than eighty percent copper) pipe shall conform to ASTM B 42 and ASTM B 43.

1107.4.3 Copper tube. Copper tube used for refrigerant piping erected on the premises shall be seamless copper tube of Type ACR (hard or annealed) complying with ASTM B 280. Where approved, copper tube for refrigerant piping erected on the premises shall be seamless copper tube of Type K, L or M (drawn or annealed) in accordance with ASTM B 88. Annealed temper copper tube shall not be used in sizes larger than a 2-inch (51 mm) nominal size. Mechan-

cal joints shall not be used on annealed temper copper tube in sizes larger than 7/8-inch (22 mm) OD size.

1107.4.4 Copper tube joints. Copper tubing joints used in refrigerating systems containing Group A2, A3, B2 or B3 refrigerants shall be brazed. Soldered joints shall not be used in such refrigerating systems.

1107.4.5 Aluminum tube. Type 3003-0 aluminum tubing with high-pressure fittings shall not be used with methyl chloride and other refrigerants known to attack aluminum.

1107.5 Joints and refrigerant-containing parts in air ducts. Joints and all refrigerant-containing parts of a refrigerating system located in an air duct of an air-conditioning system carrying conditioned air to and from humanly occupied space shall be constructed to withstand, without leakage, a pressure of 150 percent of the higher of the design pressure or pressure relief device setting.

1107.6 Exposure of refrigerant pipe joints. Refrigerant pipe joints erected on the premises shall be exposed for visual inspection prior to being covered or enclosed.

1107.7 Stop valves. All systems containing more than 6.6 pounds (3 kg) of a refrigerant in systems using positive-displacement compressors, shall have stop valves installed as follows:

1. At the inlet of each compressor, compressor unit or condensing unit.
2. At the discharge outlet of each compressor, compressor unit or condensing unit and of each liquid receiver.

EXCEPTIONS:

1. Systems that have a refrigerant pumpout function capable of storing the entire refrigerant charge in a receiver or heat exchanger.
2. Systems that are equipped with provisions for pumpout of the refrigerant using either portable or permanently installed recovery equipment.
3. Self-contained systems.

1107.7.1 Liquid receivers. All systems containing 100 pounds (45 kg) or more of a refrigerant, other than systems utilizing nonpositive displacement compressors, shall have stop valves, in addition to those required by Section 1107.7, on each inlet of each liquid receiver. Stop valves shall not be required on the inlet of a receiver in a condensing unit, nor on the inlet of a receiver which is an integral part of the condenser.

1107.7.2 Copper tubing. Stop valves used with soft annealed copper tubing or hard-drawn copper tubing 7/8-inch (22 mm) OD standard size or smaller shall be securely mounted, independent of tubing fastenings or supports.

1107.7.3 Identification. Stop valves shall be identified where their intended purpose is not obvious. Numbers shall not be used to label the valves, unless a key to the numbers is located near the valves.

[Statutory Authority: RCW 19.27.031 and 19.27.074. 98-02-056, § 51-42-1107, filed 1/6/98, effective 7/1/98.]

WAC 51-42-1108 Field test.

1108.1 General. Every refrigerant-containing part of every system that is erected on the premises, except compressors, condensers, vessels, evaporators, safety devices, pressure gauges and control mechanisms that are listed and factory tested, shall be tested and proved tight after complete installation, and before operation. Tests shall include both the high- and low-pressure sides of each system at not less than the lower of the design pressures or the setting of the pressure-relief device(s). The design pressures for testing shall be those listed on the condensing unit, compressor or compressor unit nameplate, as required by ASHRAE 15-1994.

EXCEPTIONS:

1. Gas bulk storage tanks that are not permanently connected to a refrigeration system.
2. Systems erected on the premises with copper tubing not exceeding 5/8-inch (16 mm) OD, with wall thickness as required by ASHRAE 15-1994, shall be tested in accordance with Section 1108.1, or by means of refrigerant charged into the system at the saturated vapor pressure of the refrigerant at 70°F (21°C) or higher.
3. Limited-charge systems equipped with a pressure relief device, erected on the premises, shall be tested at a pressure not less than one and one-half times the pressure setting of the relief device. If the equipment has been tested by the manufacturer at one and one-half times the design pressure, the test after erection on the premises shall be conducted at the design pressure.
4. Where a compressor is used as a booster to obtain an intermediate pressure and discharges into the suction side of another compressor, the booster compressor shall be considered a part of the low side, provided that it is protected by a pressure relief device.
5. In field-testing systems using centrifugal or other nonpositive displacement compressors, the entire system shall be considered as the low-side pressure for field test purposes.

1108.2 Test gases. Tests shall be performed with an inert dried gas including, but not limited to, nitrogen or carbon dioxide. Oxygen, air, toxic or combustible gases, and mixtures containing such gases, shall not be used.

1108.3 Test apparatus. The means used to build up the test pressure shall have either a pressure-limiting device or a pressure-reducing device and a gauge on the outlet side.

1108.4 Declaration. A certificate of test shall be provided for all systems containing 55 pounds (25 kg) or more of refrigerant. The certificate shall give the name of the refrigerant and the field test pressure applied to the high side and the low side of the system. The certification of test shall be signed by the installer and shall be made part of the public record.

[Statutory Authority: RCW 19.27.031 and 19.27.074. 98-02-056, § 51-42-1108, filed 1/6/98, effective 7/1/98.]

WAC 51-42-1109 Refrigerant piping, containers and valves. This section is not adopted.

[Statutory Authority: RCW 19.27.031, 19.27.074. 01-02-098, § 51-42-1109, filed 1/3/01, effective 7/1/01.]

WAC 51-42-1110 Erection of refrigerant piping. This section is not adopted.

[Statutory Authority: RCW 19.27.031, 19.27.074. 01-02-098, § 51-42-1110, filed 1/3/01, effective 7/1/01.]

(2003 Ed.)

WAC 51-42-1111 Refrigerant control valves. This section is not adopted.

[Statutory Authority: RCW 19.27.031, 19.27.074. 01-02-098, § 51-42-1111, filed 1/3/01, effective 7/1/01.]

WAC 51-42-1112 Pressure-limiting devices. This section is not adopted.

[Statutory Authority: RCW 19.27.031, 19.27.074. 01-02-098, § 51-42-1112, filed 1/3/01, effective 7/1/01.]

WAC 51-42-1113 Pressure-relief devices. This section is not adopted.

[Statutory Authority: RCW 19.27.031, 19.27.074. 01-02-098, § 51-42-1113, filed 1/3/01, effective 7/1/01.]

WAC 51-42-1114 Pressure-relief device settings. This section is not adopted.

[Statutory Authority: RCW 19.27.031, 19.27.074. 01-02-098, § 51-42-1114, filed 1/3/01, effective 7/1/01.]

WAC 51-42-1115 Marking of pressure-relief devices. This section is not adopted.

[Statutory Authority: RCW 19.27.031, 19.27.074. 01-02-098, § 51-42-1115, filed 1/3/01, effective 7/1/01.]

WAC 51-42-1116 Over-pressure protection. This section is not adopted.

[Statutory Authority: RCW 19.27.031, 19.27.074. 01-02-098, § 51-42-1116, filed 1/3/01, effective 7/1/01.]

WAC 51-42-1117 Discharge piping. This section is not adopted.

[Statutory Authority: RCW 19.27.031, 19.27.074. 01-02-098, § 51-42-1117, filed 1/3/01, effective 7/1/01.]

WAC 51-42-1118 Special discharge requirements. This section is not adopted.

[Statutory Authority: RCW 19.27.031, 19.27.074. 01-02-098, § 51-42-1118, filed 1/3/01, effective 7/1/01.]

WAC 51-42-1119 Ammonia discharge. This section is not adopted.

[Statutory Authority: RCW 19.27.031, 19.27.074. 01-02-098, § 51-42-1119, filed 1/3/01, effective 7/1/01.]

WAC 51-42-1120 Detection and alarm systems. This section is not adopted.

[Statutory Authority: RCW 19.27.031, 19.27.074. 01-02-098, § 51-42-1120, filed 1/3/01, effective 7/1/01.]

WAC 51-42-1121 Equipment identification. This section is not adopted.

[Statutory Authority: RCW 19.27.031, 19.27.074. 01-02-098, § 51-42-1121, filed 1/3/01, effective 7/1/01.]

WAC 51-42-1122 Testing of refrigeration equipment. This section is not adopted.

[Title 51 WAC—p. 209]

[Statutory Authority: RCW 19.27.031, 19.27.074, 01-02-098, § 51-42-1122, filed 1/3/01, effective 7/1/01.]

WAC 51-42-1123 Maintenance and operation. This section is not adopted.

[Statutory Authority: RCW 19.27.031, 19.27.074, 01-02-098, § 51-42-1123, filed 1/3/01, effective 7/1/01.]

WAC 51-42-1124 Storage of refrigerants and refrigerant oils. This section is not adopted.

[Statutory Authority: RCW 19.27.031, 19.27.074, 01-02-098, § 51-42-1124, filed 1/3/01, effective 7/1/01.]

WAC 51-42-1126 Tables not adopted.

Table 11-A - Refrigerant groups, properties and allowable quantities. This table is not adopted.

Table 11-B - Permissible refrigeration systems and refrigerants. This table is not adopted.

Table 11-C - Value of f (f) for equation 11-7. This table is not adopted.

Table 11-D - Field leak test pressures in psig. This table is not adopted.

Table 11-E - Condensate waste size. This table is not adopted.

[Statutory Authority: RCW 19.27.031, 19.27.074, 01-02-098, § 51-42-1126, filed 1/3/01, effective 7/1/01.]

WAC 51-42-1301 Section 1301—General.

1301.2 Other authorities. In addition to the Uniform Mechanical Code, provisions of chapter 480-93 WAC regarding gas pipeline safety may also apply to single meter installations serving more than one building. The provisions of chapter 480-93 WAC are enforced by the Washington Utilities and Transportation Commission.

[Statutory Authority: RCW 19.27.031, 19.27.074, 01-02-098, § 51-42-1301, filed 1/3/01, effective 7/1/01.]

WAC 51-42-1311 Material for gas piping.

1311.1 General. Pipe and tubing used for the installation, extension, alteration or repair of gas piping shall be standard weight wrought iron or steel (galvanized or black), yellow brass, seamless copper tubing, threaded copper, brass, internally tinned copper tubing, or listed corrugated stainless steel tubing (CSST). Seamless copper tubing may be used for gas piping provided that it conforms with ASTM B 88 (Type K or Type L), ASTM B 280 (Type ACR), or ASTM B 837 (Type G). Copper tubing, copper and brass pipe shall not be used if the gas contains more than an average of 0.3 grains of hydrogen sulfide per 100 standard cubic feet of gas. CSST may be permitted provided that it is part of a system listed by an approved agency as complying with the reference standard listed in chapter 16, Part III. Approved PE pipe may be used in exterior buried piping systems.

[Title 51 WAC—p. 210]

1311.3 Fittings. All fittings shall be approved for gas piping systems. The fittings shall be compatible with or shall be of the same material as the pipe or tubing. Fittings used in connection with the piping shall be of malleable iron, brass, bronze, copper, or approved plastic fittings. All fittings and components used with corrugated stainless steel tubing (CSST) shall be of the same listed system. Fittings used with copper or brass pipe shall be copper, brass, bronze or 45 degree flare fittings.

[Statutory Authority: RCW 19.27.031 and 19.27.074, 98-02-056, § 51-42-1311, filed 1/6/98, effective 7/1/98.]

WAC 51-42-1312 Installation of gas piping.

1312.1 Joints. Joints in the piping system, unless welded, brazed or flared, shall be threaded joints having approved standard threads. The threaded joints shall be made with approved pipe joint material, insoluble in fuel gas and applied to the male threads only. Welded joints in a gas-supply system shall be made by an approved, qualified welder. See Section 203. Brazing material shall have a melting point in excess of 1,000°F (520°C) and shall not contain more than 0.05 percent phosphorous.

1312.3 Piping through foundation wall. Underground piping, where installed below grade through the outer foundation or basement wall of a building, shall be encased in a protective pipe. The annular space between the gas piping and the sleeve shall be sealed at the foundation or basement wall to prevent entry of gas or water.

Existing walls shall be core drilled and sealed with an approved mechanical seal.

1312.6 Corrosion and covering protection. Metallic gas piping systems installed underground in exterior locations shall be protected from corrosion by approved coatings or wrapping materials applied in an approved manner, and cathodically protected in accordance with NACE RP-01-69. Horizontal metallic piping shall have at least 12 inches (305 mm) of earth cover or equivalent protection. Plastic gas piping shall have at least 18 inches (457 mm) of earth cover or equivalent protection. Risers, including prefabricated risers inserted with plastic pipe, shall be metallic and shall be protected in an approved manner to a point at least 6 inches (152 mm) above grade. When a riser connects to plastic pipe underground, the horizontal metallic portion underground shall be at least 30 inches (762 mm) in length before connecting to the plastic service pipe. An approved transition fitting or adaptor shall be used where the plastic joins the metallic riser.

EXCEPTION: Listed one-piece 90-degree transition fittings or risers may have less than 30 inches (762 mm) of horizontal metallic piping.

1312.7 Electrical isolation of fuel gas piping. Underground metallic gas piping systems shall be electrically isolated from other metallic structures or utilities with listed or approved isolation fittings installed a minimum of 6 inches (152 mm) above grade.

1312.17 Directional changes. Changes in direction of gas piping shall be made by use of appropriate fittings, except copper tubing, which may change direction by bending, and polyethylene gas piping and tubing, which may be bent to a radius not less than 20 times the nominal diameter of the pipe or tube.

1312.18 Marking and labeling. Copper tubing carrying fuel gas shall be identified by yellow labels marked in black letters, "Fuel Gas," or "2 PSIG Fuel Gas" for medium pressure gas piping systems carrying fuel gas at 2 PSIG pressure. Labels shall be affixed to the tubing at 12-inch (305 mm) intervals or less throughout the length of the tubing runs.

[Statutory Authority: RCW 19.27.031 and 19.27.074. 98-02-056, § 51-42-1312, filed 1/6/98, effective 7/1/98.]

WAC 51-42-1401 Oil-burning appliances.

1401 Oil-burning appliances.

Tanks, piping and valves for appliances burning fuel oil shall be installed in accordance with the requirements of recognized standards listed in part III of chapter 16.

Fuel tanks and fuel tank systems shall be taken out of service in accordance with the Fire Code.

[Statutory Authority: RCW 19.27.031 and 19.27.074. 98-02-056, § 51-42-1401, filed 1/6/98, effective 7/1/98.]

Chapter 51-44 WAC

STATE BUILDING CODE ADOPTION AND AMENDMENT OF THE 1997 EDITION OF THE UNIFORM FIRE CODE

WAC

51-44-001	Authority.
51-44-002	Purpose.
51-44-003	Uniform Fire Code.
51-44-007	Exceptions.
51-44-008	Implementation.
51-44-0103	Section 103—Inspection and enforcement.
51-44-0105	Section 105.8—Permit required.
51-44-0200	Article 2—Definitions and abbreviations.
51-44-0900	Article 9—Fire department access and water supply.
51-44-1003	Section 1003—Fire-extinguishing systems.
51-44-1007	Section 1007—Fire alarm systems.
51-44-10210	Appendix II-J—Storage of flammable and combustible liquids in tanks located within below-grade vaults.
51-44-1102	Section 1102—Incineration, open burning and commercial barbecue pits.
51-44-1109	Section 1109—Control of sources of ignition.
51-44-2500	Article 25—Places of assembly.
51-44-5200	Article 52—Motor vehicle fuel-dispensing stations.
51-44-6100	Article 61—Oil-burning equipment.
51-44-6300	Article 63—Refrigeration.
51-44-7404	Section 7404—Medical gas systems.
51-44-7802	Section 7802—Fireworks.
51-44-7900	Article 79—Flammable and combustible liquids.
51-44-8000	Article 80—Hazardous materials.

WAC 51-44-001 Authority. These rules are adopted under the authority of chapter 19.27 RCW.

[Statutory Authority: RCW 19.27.031 and 19.27.074. 98-02-053, § 51-44-001, filed 1/6/98, effective 7/1/98.]

WAC 51-44-002 Purpose. The purpose of these rules is to implement the provisions of chapter 19.27 RCW, which provides that the State Building Code council shall maintain

(2003 Ed.)

the State Building Code in a status which is consistent with the purpose as set forth in RCW 19.27.020. In maintaining the codes the council shall regularly review updated versions of the codes adopted under the act, and other pertinent information, and shall amend the codes as deemed appropriate by the council.

[Statutory Authority: RCW 19.27.031 and 19.27.074. 98-02-053, § 51-44-002, filed 1/6/98, effective 7/1/98.]

WAC 51-44-003 Uniform Fire Code. The 1997 edition of the Uniform Fire Code, including Appendix II-F, Protected Aboveground Tanks For Motor Vehicle Fuel-Dispensing Stations Outside Buildings, and Appendix II-J, Storage of Flammable and Combustible Liquids in Tanks Located Within Below-Grade Vaults, published by the International Fire Code Institute is hereby adopted by reference with the following additions, deletions, and exceptions.

[Statutory Authority: RCW 19.27.031 and 19.27.074. 98-02-053, § 51-44-003, filed 1/6/98, effective 7/1/98.]

WAC 51-44-007 Exceptions. The exceptions and amendments to the Uniform Fire Code contained in the provisions of chapter 19.27 RCW shall apply in case of conflict with any of the provisions of these rules.

The provisions of this code do not apply to temporary growing structures used solely for the commercial production of horticultural plants including ornamental plants, flowers, vegetables, and fruits. "Temporary growing structure" means a structure that has the sides and roof covered with polyethylene, polyvinyl, or similar flexible synthetic material and is used to provide plants with either frost protection or increased heat retention. A temporary growing structure is not considered a building for purposes of this code.

The provisions of this code do not apply to the construction, alteration, or repair of temporary worker housing except as provided by rule adopted under chapter 70.114A RCW or chapter 37, Laws of 1998 (SB 6168). "Temporary worker housing" means a place, area, or piece of land where sleeping places or housing sites are provided by an employer for his or her employees or by another person, including a temporary worker housing operator, who is providing such accommodations for employees, for temporary, seasonal occupancy, and includes "labor camps" under RCW 70.54.110.

[Statutory Authority: RCW 19.27.031 and 19.27.074. 98-24-078, § 51-44-007, filed 12/1/98, effective 7/1/99; 98-02-053, § 51-44-007, filed 1/6/98, effective 7/1/98.]

WAC 51-44-008 Implementation. The Uniform Fire Code adopted by chapter 51-44 WAC shall become effective in all counties and cities of this state on July 1, 1998.

[Statutory Authority: RCW 19.27.031 and 19.27.074. 98-02-053, § 51-44-008, filed 1/6/98, effective 7/1/98.]

WAC 51-44-0103 Section 103—Inspection and enforcement.

103.2.1.1 General. The chief is authorized to administer and enforce this code. Under the chief's direction, the fire department is authorized to enforce all ordinances of the jurisdiction pertaining to:

[Title 51 WAC—p. 211]

1. The prevention of fires,
2. The suppression or extinguishment of dangerous or hazardous fires,
3. The storage, use and handling of hazardous materials,
4. The installation and maintenance of automatic, manual and other private fire alarm systems and fire-extinguishing equipment,
5. The maintenance and regulation of fire escapes,
6. The maintenance of fire protection and the elimination of fire hazards on land and in buildings, structures and other property, including those under construction,
7. The maintenance of means of egress, and
8. The investigation of the cause, origin and circumstances of fire and unauthorized releases of hazardous materials.

For authority related to control and investigation of emergency scenes, see Section 104.

[Statutory Authority: RCW 19.27.031, 19.27.074, 01-02-096, § 51-44-0103, filed 1/3/01, effective 7/1/01; 98-02-053, § 51-44-0103, filed 1/6/98, effective 7/1/98.]

WAC 51-44-0105 Section 105.8—Permit required.

105.8 f.3 Flammable or combustible liquids. See Article 79.

1. To use or operate, repair or modify a pipeline for the transportation of flammable or combustible liquids.
2. To store, handle or use Class I liquids in excess of 5 gallons (18.9 L) in a building or in excess of 10 gallons (37.9 L) outside of a building, except that a permit is not required for the following:
 - 2.1 The storage or use of Class I liquids in the fuel tank of a motor vehicle, aircraft, motorboat, mobile power plant or mobile heating plant, unless such storage, in the opinion of the chief, would cause an unsafe condition.
 - 2.2 The storage or use of paints, oils, varnishes or similar flammable mixtures when such liquids are stored for maintenance, painting or similar purposes for a period of not more than 30 days.
3. To store, handle or use Class II or Class III-A liquids in excess of 25 gallons (94.6 L) in a building or in excess of 60 gallons (227.1 L) outside a building, except for fuel oil used in connection with oil-burning equipment.
4. To remove Class I or Class II liquids from an underground storage tank used for fueling motor vehicles by any means other than the approved, stationary on-site pumps normally used for dispensing purposes.
5. To install, construct, alter or operate tank vehicles, equipment, tanks, plants, terminals, wells, fuel-dispensing stations, refineries, distilleries and similar facilities where flammable and combustible liquids are produced, processed, transported, stored, dispensed or used.

6. To install, alter, remove, abandon, place temporarily out of service or otherwise dispose of a flammable or combustible liquid tank.

7. To change the type of contents stored in a flammable or combustible liquid tank to a material other than that for which the tank was designed and constructed.

8. To fuel motor vehicles directly from a tank vehicle, or to operate a site where motor vehicles are fueled directly from tank vehicles.

[Statutory Authority: RCW 19.27.031, 19.27.074, 01-02-096, § 51-44-0105, filed 1/3/01, effective 7/1/01.]

WAC 51-44-0200 Article 2—Definitions and abbreviations.

SECTION 206 - E.

ELECTRICAL CODE is the National Electrical Code, promulgated by the National Fire Protection Association, as adopted in chapter 296-46 WAC, or the locally adopted Electrical Code.

SECTION 207 - F.

FAMILY CHILD DAY CARE HOME is a child day care facility, licensed by the state, located in the family abode of the person or persons under whose direct care and supervision the child is placed, for the care of twelve or fewer children, including children who reside at the home.

SECTION 216 - O.

Group E Occupancies:

Group E Occupancies shall be:

Division 1. Any building used for educational purposes through the 12th grade by 50 or more persons for more than 12 hours per week or four hours in any one day.

Division 2. Any building used for educational purposes through the 12th grade by less than 50 persons for more than 12 hours per week or four hours in any one day.

Division 3. Any building or portion thereof used for day-care purposes for more than six persons.

EXCEPTION: Family child day care homes shall be considered Group R, Division 3 Occupancies.

Group LC Occupancies:

Group LC Occupancies shall be:

Group LC Occupancies shall include buildings, structures, or portions thereof, used for the business of providing licensed care to clients in one of the following categories regulated by either the Washington Department of Health or the Department of Social and Health Services:

1. Adult residential rehabilitation facility.
2. Alcoholism intensive inpatient treatment service.
3. Alcoholism detoxification service.
4. Alcoholism long term treatment service.
5. Alcoholism recovery house service.
6. Boarding home.

- 7. Group care facility.
- 8. Group care facility for severely and multiple handicapped children.
- 9. Residential treatment facility for psychiatrically impaired children and youth.

EXCEPTION: Where the care provided at an alcoholism detoxification service is acute care similar to that provided in a hospital, the facility shall be classified as a Group I, Division 1.1 hospital.

Group R Occupancies:

Group R Occupancies shall be:

Division 1. Hotels and apartment houses. Congregate residences (each accommodating more than 10 persons).

Division 2. Not used.

Division 3. Dwellings, family child day care homes, adult family homes, and lodging houses. Congregate residences (each accommodating 10 persons or less).

OPEN BURNING is the burning of a bonfire, rubbish fire or other fire in an outdoor location where fuel being burned is not contained in an incinerator, outdoor fireplace, barbecue grill or barbecue pit.

SECTION 219 - R.

RECREATIONAL FIRE is the burning of materials other than rubbish where fuel being burned is not contained in an incinerator, outdoor fireplace, barbecue grill or barbecue pit and with a total fuel area of 3 feet (914 mm) or less in diameter and 2 feet (610 mm) or less in height for pleasure, religious, ceremonial, cooking or similar purposes.

[Statutory Authority: RCW 19.27.031, 19.27.074. 01-02-096, § 51-44-0200, filed 1/3/01, effective 7/1/01; 98-02-053, § 51-44-0200, filed 1/6/98, effective 7/1/98.]

WAC 51-44-0900 Article 9—Fire department access and water supply.

901.2.2.1 Fire apparatus access, is not adopted.

901.4.2 Fire apparatus access roads, is not adopted.

902.1 General. Fire apparatus access roads shall be provided and maintained in accordance with locally adopted street, road, and access standards.

902.2 through 902.2.4.1, are not adopted.

[Statutory Authority: RCW 19.27.031 and 19.27.074. 98-02-053, § 51-44-0900, filed 1/6/98, effective 7/1/98.]

WAC 51-44-1003 Section 1003—Fire-extinguishing systems.

1003.2.4.1 General. An automatic fire-extinguishing system shall be installed in all newly constructed buildings classified as Group E, Division 1 Occupancy. A minimum water supply meeting the requirements of UBC Standard 9-1 shall be required. The Chief may reduce fire flow requirements for buildings protected by an approved automatic sprinkler system.

(2003 Ed.)

For the purpose of this section, additions exceeding sixty percent of the value of such building or structure, or alterations and repairs to any portion of a building or structure within a twelve month period that exceeds one hundred percent of the value of such building or structure shall be considered new construction. In the case of additions, area separation walls shall define separate buildings.

EXCEPTION: Portable school classrooms, provided:
 1. Aggregate area of clusters of portable school classrooms does not exceed 5,000 square feet (465 m²); and
 2. Clusters of portable school classrooms separated as required in chapter 5 of the Building Code.

When not required by other provisions of this chapter, a fire-extinguishing system installed in accordance with UBC Standard 9-1 may be used for increases and substitutions allowed in sections 505, 506, and 508 of the building code.

[Statutory Authority: RCW 19.27.031 and 19.27.074. 98-02-053, § 51-44-1003, filed 1/6/98, effective 7/1/98.]

WAC 51-44-1007 Section 1007—Fire alarm systems.

1007.1.3 Where new construction or modification is to be in compliance with adopted chapter 51-40 WAC, chapter 11, alarm modifications shall be designed to be compatible with the requirements of UFC Article 10.

1007.3.3.3.4 Visual alarms. Where provided, alarm systems shall include both audible and visual alarms. Visual alarm devices shall be located in hotel guest rooms as required by the building code (see UBC Washington State Amendments, Section 1105.4.9); assembly areas; accessible public- and common-use areas, including toilet rooms and bathing facilities; hallways; and lobbies. (See UBC Washington State Amendments, Section 1106.15.2, for additional information about visual signals.)

[Statutory Authority: RCW 19.27.031, 19.27.074. 01-02-096, § 51-44-1007, filed 1/3/01, effective 7/1/01; 98-02-053, § 51-44-1007, filed 1/6/98, effective 7/1/98.]

WAC 51-44-10210 Appendix II-J—Storage of flammable and combustible liquids in tanks located within below-grade vaults.

5.4 Arrangement. Each vault may contain a maximum of three tanks. Compartmentalized tanks are allowed and shall be considered as a single tank.

[Statutory Authority: RCW 19.27.031 and 19.27.074. 98-02-053, § 51-44-10210, filed 1/6/98, effective 7/1/98.]

WAC 51-44-1102 Section 1102—Incineration, open burning and commercial barbecue pits.

1102.3.1 General. Open burning shall be conducted in accordance with Section 1102.3. Open burning shall also be conducted as required by other governing agencies regulating emissions. See chapter 173-425 WAC.

EXCEPTION: Recreational fires shall be in accordance with Section 1102.4.

1102.4.1 General. Recreational fires shall be in accordance with Section 1102.4. See also chapter 173-425 WAC.

[Title 51 WAC—p. 213]

[Statutory Authority: RCW 19.27.031, 19.27.074, 01-02-096, § 51-44-1102, filed 1/3/01, effective 7/1/01.]

WAC 51-44-1109 Section 1109—Control of sources of ignition.

1109.8.3 Religious ceremonies. Participants in religious ceremonies shall not be precluded from carrying hand-held candles. See RCW 19.27.031(3).

[Statutory Authority: RCW 19.27.031, 19.27.074, 01-02-096, § 51-44-1109, filed 1/3/01, effective 7/1/01; 98-02-053, § 51-44-1109, filed 1/6/98, effective 7/1/98.]

WAC 51-44-2500 Article 25—Places of assembly.

2501.9.3 Width with Fixed Seats. Aisles in assembly occupancies with fixed seats shall comply with Section 2501.9.3. The clear width of aisles shall be based on the number of occupants within the portion of the seating areas served by the aisle.

The clear width of an aisle in inches shall not be less than the occupant load served by the aisle multiplied by 0.3 for aisles with slopes greater than 1 unit vertical to 8 units horizontal (12.5% slope) and not less than 0.2 for aisles with a slope of 1 unit vertical to 8 units horizontal (12.5% slope) or less. In addition, when the rise of steps in aisles exceeds 7 inches (178 mm), the aisle clear width shall be increased by 1 1/4 inches (32 mm) for each 100 occupants or fraction thereof served for each 1/4 inch (6.35 mm) of riser height above 7 inches (178 mm).

EXCEPTION: For buildings with smoke-protected assembly seating and for which an approved life-safety evaluation is conducted, the minimum clear width of aisles and other means of egress may be in accordance with Table 2501-B. For Table 2501-B, the number of seats specified must be within a single assembly area, and interpolation shall be permitted between the specified values shown. If Table 2501-B is used the minimum clear widths shown shall be modified in accordance with the following:

1. Where risers exceed 7 inches (178 mm) in height, multiply the stairway width in the tables by factor A, where:

$$A = 1 + \frac{(\text{riser height} - 7.0 \text{ inches})}{5} \quad (4-1)$$

$$\text{For SI: } A = 1 + \frac{(\text{riser height} - 178 \text{ mm})}{127}$$

Where risers do not exceed 7 inches (178 mm) in height, A = 1.

2. Stairways not having a handrail within a 30-inch (762 mm) horizontal distance shall be 25 percent wider than otherwise calculated, i.e., multiply by B = 1.25. For all other stairs, B = 1.

3. Ramps steeper than 1 unit vertical in 10 units horizontal (10 percent slope) where used in ascent shall have their width increased by 10 percent, i.e., multiply by C = 1.10. For ramps not steeper than 1 unit vertical in 10 units horizontal (10% slope), C = 1. Where fixed seats are arranged in rows, the clear width of aisles shall not be less than set forth above or less than the following minimum widths:

- 3.1 Forty-eight inches (1219 mm) for stairways having seating on both sides.
- 3.2 Thirty-six inches (914 mm) for stairways having seating on one side.
- 3.3 Twenty-three inches (584 mm) between a stairway handrail and seating where the aisles are subdivided by the handrail.

[Title 51 WAC—p. 214]

- 3.4 Forty-two inches (1067 mm) for level or ramped aisles having seating on both sides.
- 3.5 Thirty-six inches (914 mm) for level or ramped aisles having seating on one side.
- 3.6 Twenty-three inches (584 mm) between a stairway handrail and seating where an aisle does not serve more than five rows on one side.

Where exit access is possible in two directions, the width of such aisles shall be uniform throughout their length. Where aisles converge to form a single path of exit travel, the aisle width shall not be less than the combined required width of the converging aisles.

2501.9.5 Ramp slope. The slope of ramped aisles shall not be more than 1 unit vertical in 8 units horizontal (12.5 percent slope). Ramped aisles shall have a slip-resistant surface.

EXCEPTION: When provided with fixed seating, theaters may have a slope not steeper than 1 unit vertical to 5 units horizontal (20 percent slope).

2501.9.6.2 When required. Aisles with a slope steeper than 1 unit vertical to 8 units horizontal (12.5 percent slope) shall consist of a series of risers and treads extending across the entire width of the aisle, except as provided in subsection 2501.9.5.

The height of risers shall not be more than 8 inches (203 mm) or less than 4 inches (102 mm) and the tread run shall not be less than 11 inches (279 mm). The riser height shall be uniform within each flight and the tread run shall be uniform throughout the aisle. Variations in run or height between adjacent treads or risers shall not exceed 3/16 inch (4.8 mm). A contrasting marking stripe or other approved marking shall be provided on each tread at the nosing or leading edge such that the location of each tread is readily apparent when viewed in descent. Such stripe shall be a minimum of 1 inch (25.4 mm) wide and a maximum of 2 inches (51 mm) wide.

EXCEPTION: When the slope of aisle steps and the adjoining seating area is the same, the riser heights may be increased to a maximum of 9 inches (229 mm) and may be nonuniform but only to the extent necessitated by changes in the slope of the adjoining seating area to maintain adequate sightlines. Variations may exceed 3/16 inch (4.8 mm) between adjacent risers provided the exact location of such variations is identified with a marking stripe on each tread at the nosing or leading edge adjacent to the nonuniform riser. The marking stripe shall be distinctively different from the contrasting marking stripe.

2501.17 Candles and other open-flame devices. Candles and other open-flame devices shall not be used in places of assembly or in drinking or dining establishments.

- EXCEPTIONS:**
1. When used in conjunction with approved heating or cooking appliances in areas not accessible to the public.
 2. When used in conformance with Section 1109.8.
 3. When used in conformance with Section 8203.2.1.8.
 4. Hand-held candles carried by participants in religious ceremonies. (See RCW 19.27.031(3).)

[Statutory Authority: RCW 19.27.031, 19.27.074, 01-02-096, § 51-44-2500, filed 1/3/01, effective 7/1/01; 98-02-053, § 51-44-2500, filed 1/6/98, effective 7/1/98.]

WAC 51-44-5200 Article 52—Motor vehicle fuel-dispensing stations.

(2003 Ed.)

5201.1 Scope. Automotive, marine and aircraft motor vehicle fuel-dispensing stations shall be in accordance with Article 52 and UFC Standard 52-1. Such operations shall include both public accessible and private operations.

For provisions relating to the transfer of flammable and combustible liquids directly from tank vehicles into the fuel tanks of motor vehicles, see Section 7904.5.4.2.

The storage and use of flammable and combustible liquids and LP-gas shall also be in accordance with Articles 79 and 82.

[Statutory Authority: RCW 19.27.031, 19.27.074, 01-02-096, § 51-44-5200, filed 1/3/01, effective 7/1/01; 98-02-053, § 51-44-5200, filed 1/6/98, effective 7/1/98.]

WAC 51-44-6100 Article 61—Oil-burning equipment.

SECTION 6102 - GENERAL.

The design, construction and installation of oil-burning equipment shall be in accordance with the Mechanical Code. Oil-burning equipment shall be of an approved type. Tanks and piping serving oil-burning equipment which has been out of service for a period of one year shall be removed from the ground or property or abandoned in place in accordance with Section 7902.1.7 of this code.

SECTION 6103 - PERMITS.

A permit is required to remove, abandon, place temporarily out of service or otherwise dispose of a combustible liquids tank. See Section 105.8, permit f.3. Such a permit may be issued without an inspection of the tank or premises as otherwise required in Section 105.4.

SECTION 6106 - PORTABLE UNVENTED OIL-BURNING HEATING APPLIANCES AND UNVENTED DECORATIVE GAS LOGS AND FIREPLACES.

6106.1 General. The design, construction and use of portable unvented oil-burning heating appliances shall be in accordance with Section 6106 and other applicable provisions of this code.

6106.2 Equipment. Portable unvented oil-burning heating appliances shall be listed and shall be limited to a fuel tank capacity of 2 gallons (7.6 L).

EXCEPTION: Appliances approved for temporary use during construction processes are allowed to have a greater fuel tank capacity, provided such capacity does not exceed the terms of the listing of the appliance.

6106.3 Location. The use of listed portable unvented oil-burning heating appliances shall be limited to supplemental heating in Groups S, Divisions 3, 4, and 5 and Group U Occupancies.

EXCEPTIONS:

1. When approved, portable unvented oil-burning heating appliances may be used in any occupancy during construction processes when such use is necessary for the construction and the use does not represent a hazard to life or property.
2. Approved, unvented portable oil-fueled heaters may be used as a supplemental heat source in any Group B, F-2, M, R or U Occupancy provided that such heaters shall not be located in any sleeping room or bathroom, and shall comply with RCW

19.27A.080, 19.27A.090, 19.27A.100, 19.27A.110, and 19.27A.120.

3. Approved, unvented decorative gas logs and decorative fireplaces may be installed, used, maintained and permitted to exist in any Group I or R Occupancy, except bathrooms and bedrooms. An unvented decorative gas log is a listed natural or liquefied petroleum gas burning log with an open flame consisting of a metal frame or base supporting simulated logs which is designed so that its primary function lies in the aesthetic effect of the logs and flame. An unvented decorative fireplace is a listed unvented gas log permanently installed in a freestanding enclosure or zero clearance enclosure designed and approved for installation in walls or other building structures. Unvented decorative gas logs and fireplaces shall:

1. Be equipped with an approved oxygen-depletion sensor,
2. Be listed,
3. Not be installed in any room which does not have an alternative primary source of heat,
4. Have free air volume of at least 50 cubic feet (1.4 m³) for each 1,000 Btu (2.2 mm²/W) of thermal output, and
5. Be permanently installed.

6106.4 Fuel. The grade and type of fuel shall be in accordance with the listing for the appliance. Storage and handling of fuel shall be in accordance with Article 79.

[Statutory Authority: RCW 19.27.031 and 19.27.074, 98-02-053, § 51-44-6100, filed 1/6/98, effective 7/1/98.]

WAC 51-44-6300 Article 63—Refrigeration.

SECTION 6301 - SCOPE.

6301.1 This article shall govern the design, installation, construction and repair of refrigeration systems that vaporize and liquefy a fluid during the refrigerating cycle. Refrigerant piping design and installation, including pressure vessels and pressure relief devices, shall conform to this code. Permanently installed refrigerant storage systems and other components shall be considered as part of the refrigeration system to which they are attached.

6301.2 Refrigeration unit and system installations having a refrigerant circuit containing more than 220 pounds (100 kg) of Group A1 or 30 pounds (13.6 kg) of any other group refrigerant shall be in accordance with Article 63 and the Mechanical Code. See the Mechanical Code for refrigerant group descriptions. See also Sections 8001.1.2 and 8002.

EXCEPTION: The chief is authorized to exempt temporary or portable installations.

6301.3 Refrigeration systems shall comply with the requirements of this code and, except as modified by this code, ASHRAE 15 - 1994. Ammonia refrigerating systems shall comply with this code and, except as modified by this code, ASHRAE 15 - 1994 and IIAR 2 - 1992.

SECTION 6309 - AMMONIA DISCHARGE.

Ammonia refrigeration systems shall be designed and installed in accordance with ASHRAE 15 - 1994 Section 9.7.8.2, Ammonia Discharge.

EXCEPTION: An emergency discharge is not required for ammonia-water absorption unit systems installed outdoors provided that the discharge is shielded and dispersed.

SECTION 6310 - REFRIGERATION MACHINERY ROOMS.

6310.1 When Required. Where required by UMC Table 1104.2(1), a machinery room shall be provided to enclose refrigeration systems located indoors. Access to the machinery room shall be restricted to authorized personnel. For rooms where occupational exposure could occur, see WAC 269-62-07515 and 296-62-3112.

6310.2 Dimensions. A machinery room shall be dimensioned so as to provide clearances required by UMC Chapter 3. There shall be clear head room of not less than 7 feet 3 inches (2210 mm).

6310.3 Means of egress. Means of egress shall comply with Uniform Building Code Section 1020 - Special Hazards.

Each machinery room shall be provided with a minimum of one exit door that opens directly to the outside.

EXCEPTION: Self-closing, tight-fitting doors opening into a vestibule leading directly outside.

6310.4 Refrigerant-vapor Alarms. Machinery rooms shall contain a refrigerant vapor detector with an audible and visual alarm. The detector, or a sampling tube that draws air to the detector, shall be located in an area where refrigerant vapor from a leak will concentrate. The alarm shall be actuated at a value not greater than the corresponding TLV - TWA values shown in UMC Table 1104.1. Detectors and alarms shall be placed in approved locations.

EXCEPTION: Detectors are not required for ammonia systems complying with UMC Section 1106.8.

6310.7 Special Requirements. Open flames that use combustion air from the machinery room shall not be installed in a machinery room.

EXCEPTIONS:

1. Matches, lighters, halide leak detectors and similar devices.
2. Where the refrigerant is carbon dioxide or water.
3. Fuel burning equipment shall not be prohibited in the same machinery room with refrigerant-containing equipment where combustion air is ducted from outside the machinery room and sealed in such a manner as to prevent any refrigerant leakage from entering the combustion chamber, or where a refrigerant vapor detector is employed to automatically shut off the combustion process in the event of refrigerant leakage.

SECTION 6311 - REFRIGERATION MACHINERY ROOM VENTILATION.

6311.1 General. Machinery rooms shall be mechanically ventilated to the outdoors. Mechanical ventilation shall be capable of exhausting the minimum quantity of air both at the normal operating and emergency conditions. Multiple fans or multispeed fans shall be allowed in order to produce the emergency ventilation rate to obtain a reduced airflow for normal ventilation.

EXCEPTION: Where a refrigerating system is located outdoors more than 20 feet (6096 mm) from any building opening and is enclosed by a penthouse, lean-to or other structure, natural or mechanical ventilation shall be provided in accordance with UMC Section 1105.9.

6311.2 Distribution of Ventilation. Provisions shall be made for supply air to replace that being exhausted. Openings for supply air shall be located to avoid intake of exhaust air.

Air supply and exhaust ducts to the machinery room shall comply with the provisions of UMC Section 1105.9.

6311.3 Intermittent Control of Ventilation Systems. Fans providing refrigeration machinery room temperature control or automatic response to refrigerant vapor are allowed to be automatically controlled to provide intermittent ventilation as conditions require.

6311.4 Emergency Control of Ventilation Systems. Fans providing emergency purge ventilation for refrigerant escape shall have a clearly identified switch of the break-glass type providing on-only control immediately adjacent to and outside of each refrigerant machinery room exit. Purge fans shall also respond automatically to the refrigerant concentration detection system set to activate the ventilation system at values not greater than the corresponding TLV - TWA values shown in UMC Table 1104.1. Ventilation equipment in ammonia machinery rooms equipped with a refrigerant vapor detector that will automatically start the ventilation system and actuate an alarm may be set at detection levels which exceed those in UMC Table 1104.1 but such detection level setting shall not exceed 1,000 ppm. An emergency purge control shall be provided with a manual reset only.

6311.6 Ventilation Discharge. Exhaust from mechanical ventilation systems shall be discharged 20 feet (6096 mm) or more from a property line or openings into buildings. Also see Section 6308.

6311.7 Fans. Fans and associated equipment intended to operate the emergency purge of other than Group A1 or Group B1 refrigerants shall meet the requirements for a Class I, Division 1 hazardous location as specified in the Electrical Code.

EXCEPTION: Ammonia machinery rooms.

SECTION 6313 - DETECTION AND ALARM SYSTEMS.

6313.2.1 Alarm. Refrigerant vapor alarms shall be activated at a value not greater than the corresponding TLV - TWA values shown in UMC Table 1104.1.

EXCEPTION: Alarms in ammonia machinery rooms may be activated by a detector setting not to exceed 1,000 ppm when the activation of the detector will automatically start the ventilation system.

6313.2.2 Automatic shutdown, is not adopted.

SECTION 6314 - REFRIGERATION MACHINERY ROOM EQUIPMENT AND CONTROLS.

6314.4 Emergency Control. A clearly identified switch of the break-glass type providing off-only control of electrically energized equipment and devices within the refrigeration machinery room shall be provided immediately adjacent to and outside of each refrigeration machinery room means of egress.

SECTION 6315 - REFRIGERANT CONTROL VALVES.

6315.2 Support. Stop valves installed in copper refrigerant lines of 7/8 inch (22 mm) or less outside diameter shall be securely supported independently of the tubing or piping.

SECTION 6318 - INSTRUCTIONS.

The person in charge of premises on which a refrigeration unit or system is installed shall provide an approved card located in the emergency control box designating:

1. Instructions for suspending operation of the system in the event of an emergency,
2. The name, address, and emergency telephone numbers to obtain emergency service,
3. The name, address, and telephone number of the fire department with instructions to notify the fire department in the event of an emergency,
4. The names, addresses, and telephone numbers of all corporate, local, state, and federal agencies to be contacted as required in the event of a reportable incident, and,
5. The location and operation of emergency discharge systems when such systems are required by Article 63.

[Statutory Authority: RCW 19.27.031 and 19.27.074. 98-02-053, § 51-44-6300, filed 1/6/98, effective 7/1/98.]

WAC 51-44-7404 Section 7404—Medical gas systems.

7404.1 General. Compressed gases at hospitals and similar facilities intended for inhalation or sedation including, but not limited to, analgesia systems for dentistry, podiatry, veterinary and similar uses shall be in accordance with Section 7404 in addition to other requirements of Article 74.

EXCEPTION: All distribution piping, supply manifolds, connections, regulators, valves, alarms, sensors and associated equipment shall be in accordance with the plumbing code.

7404.2.3 - Medical gas systems, is not adopted.

[Statutory Authority: RCW 19.27.031 and 19.27.074. 98-02-053, § 51-44-7404, filed 1/6/98, effective 7/1/98.]

WAC 51-44-7802 Section 7802—Fireworks.

7802.1 General. Storage, use and handling of fireworks shall be in accordance with chapter 70.77 RCW and local ordinances consistent with chapter 70.77 RCW.

7802.2 Seizure of Fireworks, through 7802.4.9.8.10 Record, is not adopted.

[Statutory Authority: RCW 19.27.031 and 19.27.074. 98-02-053, § 51-44-7802, filed 1/6/98, effective 7/1/98.]

WAC 51-44-7900 Article 79—Flammable and combustible liquids.

SECTION 7901.2.2—DEFINITIONS - LIMITED APPLICATION.

AUTO START AND STOP NOZZLE is an approved dispensing nozzle that is not capable of dispensing liquid unless the nozzle is in contact with the fuel fill opening of the motor vehicle. The nozzle must be incapable of dispensing liquid until the nozzle has entered the fuel fill opening of the motor vehicle fuel tank. The nozzle will automatically stop dispensing prior to fully extracting the nozzle from the fuel tank opening.

(2003 Ed.)

MOTOR VEHICLE includes, but is not limited to, a vehicle, machine, tractor, trailer, or semi-trailer, or any combination thereof, propelled or drawn by mechanical power and used upon the highways in the transportation of passengers or property. The term "motor vehicle" also includes freight containers or cargo tanks used, or intended for use, in connection with motor vehicles. For reference, see 49 CFR Pt. 171.8 (October 1994).

REMOTE EMERGENCY SHUT-OFF DEVICE is a device capable of halting the pumping of fuel from the furthest point at which the fuel is being dispensed, but not less than 100 feet.

SECTION 7902 - STORAGE.

7902.1.7.2.4 Tanks abandoned in place. Tanks abandoned in place shall be abandoned as follows:

1. Flammable and combustible liquids shall be removed from the tank and connected piping,
 2. The suction, inlet, gage, vapor return and vapor lines shall be disconnected,
 3. The tank shall be filled completely with an approved, inert solid material,
- EXCEPTION:** Residential heating oil tanks of 1,100 gallons (4,164 L) or less, provided the fill line is permanently capped or plugged, below grade, to prevent refilling of the tank.
4. Remaining underground piping shall be capped or plugged, and
 5. A record of the tank size, location and date of abandonment shall be retained.

7902.6.8 Leaking tanks. Leaking tanks shall be handled in accordance with WAC 173-360-325.

7902.6.10 Tank lining. Steel tanks are allowed to be lined only for the purpose of protecting the interior from corrosion or providing compatibility with a material to be stored. Only those liquids tested for compatibility with the lining material are allowed to be stored in lined tanks. Lining of leaking underground storage tanks shall be done in accordance with the provisions of WAC 173-360-325.

7902.6.15.2 Cathodic protection. Cathodic protection systems provided for corrosion protection shall be in accordance with recognized standards. See WAC 173-360-320.

SECTION 7903 - DISPENSING, USE, MIXING AND HANDLING.

7903.4 Solvent Distillation Units.

7903.4.1 General. Solvent distillation units used to recycle Class I, II or III-A liquids having a distillation chamber capacity of 60 gallons (227.1 L) or less shall be listed, labeled and installed in accordance with Section 7903.4 and nationally recognized standards. See Article 90, Standard u.1.17.

EXCEPTIONS:

1. Solvent distillation units installed in dry-cleaning plants in accordance with Section 3603.
2. Solvent distillation units used in continuous throughput industrial processes where the source of heat is remotely supplied using steam, hot water, oil or

[Title 51 WAC—p. 217]

other heat-transfer fluids, the temperature of which is below the auto-ignition point of the solvent(s).

3. Approved research, testing and experimental processes.

Solvent-distillation units used to recycle Class I, II or III-A liquids, having a distillation chamber capacity exceeding 60 gallons (227.1 L) shall be used in locations that comply with the use and mixing requirements of Section 7903 and other applicable provisions in Article 79.

Classes I, II and III-A liquids also classified as unstable (reactive) shall not be processed in solvent-distillation units.

EXCEPTION: Appliances listed for the distillation of unstable (reactive) solvents.

SECTION 7904 - SPECIAL OPERATIONS.

7904.5.4.2 Destination of liquids off loaded from tank vehicles and tank cars.

7904.5.4.2.1 General. Class I, II or III liquids shall be transferred from a tank vehicle or tank car only into an approved atmospheric tank or approved portable tank, except as provided in Sections 7904.5.4.2.2 through 7904.5.4.2.7.

7904.5.4.2.2 Marine craft and special equipment. Liquids intended for use as motor fuels are allowed to be transferred from tank vehicles into the fuel tanks of marine craft and special equipment when approved, and when:

1. The tank vehicle's specific function is that of supplying fuel to fuel tanks and each premises shall require a separate permit issued in accordance with Section 105,

2. The operation shall be performed only where the general public has no access or where there is no unusual exposure to life and property,

3. The dispensing line shall not exceed 50 feet (15 240 mm) in length, and

4. The dispensing nozzle is approved.

7904.5.4.2.2.1 Vehicle fueling. When approved by the chief, dispensing of motor vehicle fuel from tank vehicles into the fuel tanks of motor vehicles is allowed in accordance with Article 52 and Sections 7904.2 and 7904.5.4.2.

7904.5.4.2.7 Fueling of motor vehicles from tank vehicles.

7904.5.4.2.7.1 General. The transfer of gasoline or other Class I flammable liquid into the fuel tank of a motor vehicle is prohibited except as provided for in Sections 7904.5.4.2.2 through 7904.5.4.2.6. The transfer of a Class II combustible liquid (e.g., diesel fuel) into the fuel tank of a motor vehicle shall be in accordance with Section 7904.5.4.2.7, except as provided for in Sections 7904.5.4.2.2 through 7904.5.4.2.6.

7904.5.4.2.7.2 Permits and plans. See also Section 105.8, Permit f.3. A permit is required:

1. To transfer fuel into a motor vehicle directly from a tank vehicle.

2. For any site where fuel is transferred into the fuel tank of a motor vehicle directly from a tank vehicle.

The following information shall be included with any application for permit to transfer fuel into a motor vehicle from a tank vehicle:

- License number of each fuel delivery vehicle.
- Proof of tank vehicle compliance with 49 CFR 178 requirements and inspections. Documentation showing inspection approval of the vehicles by a USDOT registered inspector shall be proof of compliance.
- An approved Spill Response Plan.

The following information shall be included with any application to utilize a site for the transfer of fuel into motor vehicles from tank vehicles:

- A site plan showing all property lines, buildings, facilities, hazardous materials, parking, lighting, fencing, openings into buildings, storm drains, unpaved areas, lanes of egress and the proposed location(s) of fueling.

7904.5.4.2.7.3 Fuel delivery vehicles.

7904.5.4.2.7.3.1 Maintenance. All required equipment, safety features and devices on the fuel delivery vehicle shall be maintained in full working order at all times.

7904.5.4.2.7.3.2 Compliance with USDOT regulations. Fuel delivery vehicles shall comply with all applicable 49 CFR 178 requirements. Documentation from a USDOT registered inspector shall be available for review by the fire department and shall be proof of compliance.

7904.5.4.2.7.3.3 Fuel dispensing hoses. The fueling hose shall not be extended beyond 50 feet.

EXCEPTION: The fueling hose may be extended up to a distance of 125 feet if the operator carries an approved remote emergency shut-off device capable of stopping the flow of fuel. The demonstrated distance by which the remote emergency shut-off reliably operates shall determine the approved hose distance or as denoted by the manufacturer, whichever distance is less. The hose shall be clearly marked at the approved distance. The approved distance marking on the hose shall consist of a band, the length of which shall be a minimum of 12 inches. The marking shall be of contrasting color to the hose.

All pressure hoses and couplings shall be inspected at intervals appropriate to the service. Any hose showing materials deterioration, signs of leakage or weakness in its carcass or at the couplings shall be withdrawn from service and repaired or discarded.

7904.5.4.2.7.3.4 Hose diameter. The inside diameter of the delivery hose shall not exceed 1-1/4 inches.

7904.5.4.2.7.3.5 Spill control equipment. Fuel delivery vehicles shall be equipped with clean-up supplies in accordance with the Department of Ecology's Storm-water Management in Washington State Volume IV Source Control Best Management Practice Number S1.11. Such supplies shall be readily available for employment by the operator at all times.

7904.5.4.2.7.3.6 Nozzle. The dispensing nozzle shall be an approved listed automatic closing type hose nozzle without a latch-open device or an approved auto start and stop nozzle with a latch-open device.

7904.5.4.2.7.3.7 Emergency shut-off valve. The fuel delivery vehicle shall have an approved emergency shut-off valve on the fuel delivery vehicle.

7904.5.4.2.7.3.8 Fire extinguisher. The fuel delivery vehicle shall have a fire extinguisher with a minimum rating of 2A 20BC located in a readily accessible location.

7904.5.4.2.7.4 Operation requirements.

7904.5.4.2.7.4.1 Training. Fuel delivery vehicle operators shall comply with current training and certification requirements in accordance with local, state and federal regulations for handling, dispensing and transporting hazardous materials.

7904.5.4.2.7.4.2 Notification of spills. The fuel delivery vehicle operator shall, without delay, directly notify the fire department via 911 when an unauthorized discharge becomes reportable under state, federal or local regulations or when any spill or accidental release is not contained by spill prevention measures.

7904.5.4.2.7.4.3 Location of attendant during dispensing. The attendant shall be located at the nozzle at all times when fuel is being dispensed.

7904.5.4.2.7.4.4 Signage. Signs stating NO SMOKING or OPEN FLAME WITHIN 25 FEET, or an approved equivalent, shall be visible and readable at the fueling site.

7904.5.4.2.7.4.5 Emergency communication. Each tanker shall have a mobile or portable phone or two-way radio to an attended base.

7904.5.4.2.7.4.6 Warning lights. The fuel delivery vehicle's parking brake and the hazard warning lights shall be activated during fueling operations.

7904.5.4.2.7.4.7 Spill prevention.

7904.5.4.2.7.4.7.1 Overfill and drip protection. Operators shall place a drip pan or absorbent, in good condition, under each fuel fill opening prior to and during all dispensing operations. Drip pans shall be liquid tight. The pan or absorbent shall have a capacity of at least 3 gallons. Spills retained in the drip pan or absorbent pillow need not be reported. Operators, when fueling, shall have on their persons an absorbent pad capable of capturing diesel foam overfills. Except during fueling, the nozzle shall face upwards and an absorbent pad shall be kept under the nozzle to prevent drips. Contaminated absorbent pads shall be disposed of regularly in accordance with local, state and federal requirements.

7904.5.4.2.7.4.7.2 Topping off. Fuel expansion space shall be provided in each motor vehicle tank to prevent overflow. Tanks shall not be topped off. The operator shall cease filling and remove the fill nozzle if the automatic shut-off engages.

7904.5.4.2.7.4.8 Lighting. The operator shall provide lighting that provides clear illumination at the point of fueling. General lighting of the fueling area shall be provided for nighttime fueling.

7904.5.4.2.7.4.9 Vehicle motor shutdown. The vehicle being fueled shall be shut off during fueling operations.

7904.5.4.2.7.4.10 Fuel hoses. At no time shall the fueling hose extend across a trafficable lane without fluorescent traffic cones conspicuously placed so that all vehicle traffic is blocked.

The fuel hose shall be returned to its storage location on the vehicle prior to repositioning the vehicle. At no time shall the hose be allowed to drag behind the vehicle while it is in motion.

7904.5.4.2.7.5 Site requirements.

7904.5.4.2.7.5.1 Property owner's consent. All persons and parties with an interest in the property (i.e., property owner, lessor, real estate company, property manager as well as operators of the property) must give consent in writing to allow the mobile fueling to occur on the property. Managers, lessees, renters and other persons cannot solely give permission. Each person or party must indicate that they understand the risk of spills.

7904.5.4.2.7.5.2 Location of fueling. The fuel dispensing vehicle and the fueling operation shall be at least 15 feet from all property lines, streets, alleys, public ways, building openings and storm drains.

EXCEPTIONS:

1. The distance to storm drains can be eliminated if an approved storm drain cover or an approved equivalent that will prevent any fuel from reaching the drain is in place prior to fueling or hose being placed within 15 feet of the drain. When placement of a storm drain cover will cause the accumulation of excessive water or difficulty in safely conducting the fueling, it shall not be used and fueling shall not take place within 15 feet of a drain.
2. The distance to storm drains can be eliminated for drains that direct intake to approved oil-water separators.

7904.5.4.2.7.5.3 Sources of ignition. Fuel dispensing is prohibited within 15 feet of any source of ignition.

7904.5.4.2.7.5.4 Access. Mobile fueling operations shall not be performed during times when the public has access to the area unless restricted by remoteness of the property, fencing or other control measures.

[Statutory Authority: RCW 19.27.031, 19.27.074. 01-02-096, § 51-44-7900, filed 1/3/01, effective 7/1/01; 98-02-053, § 51-44-7900, filed 1/6/98, effective 7/1/98.]

WAC 51-44-8000 Article 80—Hazardous materials.

SECTION 8001 - GENERAL.

8001.3.2 Hazardous materials management plan. When required by the chief, each application for a permit shall include a hazardous materials management plan (HMMP). The location of the HMMP shall be posted adjacent to permits when an HMMP is provided. The HMMP shall include a facility site plan designating the following:

1. Storage and use areas,
2. Maximum amount of each material stored or used in each area,
3. Range of container sizes,

- 4. Locations of emergency isolation and mitigation valves and devices,
- 5. Product conveying piping containing liquids or gases, other than utility-owned fuel gas lines and low-pressure fuel gas lines,
- 6. On and off positions of valves for valves which are of the self-indicating type, and
- 7. Storage plan showing the intended storage arrangement, including the location of aisles.

The plans shall be legible and approximately to scale. Separate distribution systems are allowed to be shown on separate pages.

See also Appendix II-E.

SECTION 8003 - STORAGE.

8003.3.2.3 Canopies. Portable tanks and cylinders stored outside of buildings shall be stored under a canopy of non-combustible construction. Such storage shall not be considered indoor storage. See also Section 8003.1.14.

EXCEPTION: Portable tanks and cylinders used for storing anhydrous ammonia (fertilizer grade).

An automatic fire-sprinkler system shall be provided for canopies used for storage of highly toxic or toxic compressed gases.

EXCEPTION: Where water is incompatible with the hazardous material stored, the chief may approve alternate fire suppression methods to an automatic sprinkler system.

[Statutory Authority: RCW 19.27.031 and 19.27.074. 98-02-053, § 51-44-8000, filed 1/6/98, effective 7/1/98.]

**Chapter 51-45 WAC
STATE BUILDING CODE ADOPTION AND
AMENDMENT
OF THE 1997 EDITION OF THE UNIFORM FIRE
CODE STANDARDS**

WAC

51-45-001	Authority.
51-45-002	Purpose.
51-45-003	Uniform Fire Code Standards.
51-45-007	Exceptions.
51-45-008	Implementation.
51-45-80400	Standard 80-4—Inert cryogenic fluid systems at consumer sites.

WAC 51-45-001 Authority. These rules are adopted under the authority of chapter 19.27 RCW.

[Statutory Authority: RCW 19.27.031 and 19.27.074. 98-02-053, § 51-45-001, filed 1/6/98, effective 7/1/98.]

WAC 51-45-002 Purpose. The purpose of these rules is to implement the provisions of chapter 19.27 RCW, which provides that the State Building Code council shall maintain the State Building Code in a status which is consistent with the purpose as set forth in RCW 19.27.020. In maintaining the codes the council shall regularly review updated versions of the codes adopted under the act, and other pertinent information, and shall amend the codes as deemed appropriate by the council.

[Title 51 WAC—p. 220]

[Statutory Authority: RCW 19.27.031 and 19.27.074. 98-02-053, § 51-45-002, filed 1/6/98, effective 7/1/98.]

WAC 51-45-003 Uniform Fire Code Standards. The 1997 edition of the Uniform Fire Code Standards as published by the International Fire Code Institute is hereby adopted by reference with the following additions, deletions, and exceptions.

[Statutory Authority: RCW 19.27.031 and 19.27.074. 98-02-053, § 51-45-003, filed 1/6/98, effective 7/1/98.]

WAC 51-45-007 Exceptions. The exceptions and amendments to the Uniform Fire Code Standards contained in the provisions of chapter 19.27 RCW shall apply in case of conflict with any of the provisions of these rules.

[Statutory Authority: RCW 19.27.031 and 19.27.074. 98-02-053, § 51-45-007, filed 1/6/98, effective 7/1/98.]

WAC 51-45-008 Implementation. The Uniform Fire Code Standards adopted by chapter 51-45 WAC shall become effective in all counties and cities of this state on July 1, 1998.

[Statutory Authority: RCW 19.27.031 and 19.27.074. 98-02-053, § 51-45-008, filed 1/6/98, effective 7/1/98.]

WAC 51-45-80400 Standard 80-4—Inert cryogenic fluid systems at consumer sites.

Section 5.2.1.2 When bulk inert gas systems are installed in a building of other than Type I or II construction, an approved, supervised automatic sprinkler system shall be provided in the room or area in which the system is installed. Activation of the automatic sprinkler system shall initiate a local alarm and transmit a signal to a constantly attended control station.

[Statutory Authority: RCW 19.27.031 and 19.27.074. 98-02-053, § 51-45-80400, filed 1/6/98, effective 7/1/98.]

**Chapter 51-56 WAC
STATE BUILDING CODE ADOPTION AND
AMENDMENT OF THE 2000 EDITION OF THE
UNIFORM PLUMBING CODE**

WAC

51-56-001	Authority.
51-56-002	Purpose.
51-56-003	Uniform Plumbing Code.
51-56-007	Exceptions.
51-56-008	Implementation.
51-56-0100	Chapter 1—Administration.
51-56-0200	Chapter 2—Definitions.
51-56-0300	Chapter 3—General regulations.
51-56-0400	Chapter 4—Plumbing fixtures and fixture fittings.
51-56-0500	Chapter 5—Water heaters.
51-56-0600	Chapter 6—Water supply and distribution.
51-56-0700	Chapter 7—Sanitary drainage.
51-56-0800	Chapter 8—Indirect wastes.
51-56-0900	Chapter 9—Vents.
51-56-1300	Chapter 13—Health care facilities and medical gas and vacuum systems.
51-56-1400	Chapter 14—Referenced standards.
51-56-201300	Appendix M—Storm drainage.

WAC 51-56-001 Authority. These rules are adopted under the authority of chapter 19.27 RCW.

[Statutory Authority: RCW 19.27.031, 19.27.074. 02-01-114, § 51-56-001, filed 12/18/01, effective 7/1/02.]

WAC 51-56-002 Purpose. The purpose of these rules is to implement the provisions of chapter 19.27 RCW, which provides that the state building code council shall maintain the State Building Code in a status which is consistent with the purpose as set forth in RCW 19.27.020. In maintaining the codes, the council shall regularly review updated versions of the codes adopted under the act, and other pertinent information, and shall amend the codes as deemed appropriate by the council.

[Statutory Authority: RCW 19.27.031, 19.27.074. 02-01-114, § 51-56-002, filed 12/18/01, effective 7/1/02.]

WAC 51-56-003 Uniform Plumbing Code. The 2000 edition of the Uniform Plumbing Code, published by the International Association of Plumbing and Mechanical Officials, is hereby adopted by reference with the following additions, deletions and exceptions: Provided that chapters 11, 12 and 15 of this code are not adopted. Provided further, that those requirements of the Uniform Plumbing Code relating to venting and combustion air of fuel fired appliances as found in chapter 5 and those portions of the code addressing building sewers are not adopted.

[Statutory Authority: RCW 19.27.031, 19.27.074. 02-01-114, § 51-56-003, filed 12/18/01, effective 7/1/02.]

WAC 51-56-007 Exceptions. The exceptions and amendments to the uniform codes contained in the provisions of chapter 19.27 RCW shall apply in cases of conflict with any of the provisions of these rules.

[Statutory Authority: RCW 19.27.031, 19.27.074. 02-01-114, § 51-56-007, filed 12/18/01, effective 7/1/02.]

WAC 51-56-008 Implementation. The Uniform Plumbing Code adopted by chapter 51-56 WAC shall become effective in all counties and cities of this state on July 1, 2002, unless local government residential amendments have been approved by the state building code council.

[Statutory Authority: RCW 19.27.031, 19.27.074. 02-01-114, § 51-56-008, filed 12/18/01, effective 7/1/02.]

WAC 51-56-0100 Chapter 1—Administration.

101.4.1.4 Conflict Between Codes. Delete paragraph.

102.4 Appeals. All persons shall have the right to appeal a decision of the administrative authority. The jurisdiction shall have a board of appeals to hear and rule on Plumbing Code appeals. Members of the board shall be appointed by the jurisdiction. Decisions by the board shall be reported to the jurisdiction and administered by the administrative authority.

103.1.3 Certification. State rules and regulations concerning certification shall apply.

[Statutory Authority: RCW 19.27.031, 19.27.074. 02-01-114, § 51-56-0100, filed 12/18/01, effective 7/1/02.]

WAC 51-56-0200 Chapter 2—Definitions.

(2003 Ed.)

205.0 Certified Backflow Assembly Tester - A person certified by the Washington state department of health under chapter 246-292 WAC to inspect (for correct installation and approval status) and test (for proper operation) approved backflow assemblies.

208.0 Flammable Vapor or Fumes is the concentration of flammable constituents in air that exceeds 10 percent of its lower flammability limit (LFL).

218.0 Plumbing System - Includes all potable water building supply and distribution pipes, all plumbing fixtures and traps, all drainage and vent pipe(s), and all building drains including their respective joints and connection, devices, receptors, and appurtenances within the property lines of the premises and shall include potable water piping, potable water treating or using equipment, medical gas and medical vacuum systems, and water heaters: Provided, That no certification shall be required for the installation of a plumbing system within the property lines and outside a building.

[Statutory Authority: RCW 19.27.031, 19.27.074. 02-01-114, § 51-56-0200, filed 12/18/01, effective 7/1/02.]

WAC 51-56-0300 Chapter 3—General regulations.

301.1.1 Approvals. Unless otherwise provided for in this code, all materials, fixtures or devices used or entering into the construction of plumbing systems, or parts thereof, shall be submitted to the administrative authority for approval and shall conform to approved nationally recognized standards, and shall be free from defects. All pipe, fittings, traps, fixtures, material and devices used in a plumbing system shall be listed or labeled by a listing agency or shall be approved by the administrative authority.

301.1.3 Standards. Standards listed or referred to in this chapter and Table 14-1 cover materials that conform to the requirements of this code, when used in accordance with the limitations imposed in this or other chapters thereof and their listing. Where a standard covers materials of various grades, weights, quality, or configurations, there may be only a portion of the listed standard which is applicable. Design and materials for special conditions or materials not provided for herein are allowed to be used only by special permission of the administrative authority after the administrative authority has been satisfied as to their adequacy in accordance with Section 301.2.

311.4 Except as hereinafter provided in Sections 908.0, 909.0, 910.0, and Appendix L, Section L 6.0, no vent pipe shall be used as a soil or waste pipe, nor shall any soil or waste pipe be used as a vent.

313.6 No water, soil, or waste pipe shall be installed or permitted outside of a building or in an exterior wall unless, where necessary, adequate provision is made to protect such pipe from freezing. All hot and cold water pipes installed outside the conditioned space shall be insulated to a minimum R-3.

313.7 All pipe penetrating floor/ceiling assemblies and fire-resistance rated walls or partitions shall be protected in accordance with the requirements of the building code.

316.1.6 Solvent Cement Plastic Pipe Joints. Plastic pipe and fittings designed to be joined by solvent cementing shall comply with this code and the manufacturer's installation instructions.

ABS pipe and fittings shall be cleaned and then joined with listed solvent cement(s).

CPVC and PVC pipe and fittings shall be cleaned and joined with listed primer(s) and solvent cement(s).

[Statutory Authority: RCW 19.27.031, 19.27.074, 02-01-114, § 51-56-0300, filed 12/18/01, effective 7/1/02.]

WAC 51-56-0400 Chapter 4—Plumbing fixtures and fixture fittings.

402.0 Water-Conserving Fixtures and Fittings.

402.1 The purpose of this section shall be to implement water conservation performance standards in accordance with RCW 19.27.170.

402.2 Application. This section shall apply to all new construction and all remodeling involving replacement of plumbing fixtures and fittings in all residential, hotel, motel, school, industrial, commercial use, or other occupancies determined by the council to use significant quantities of water. Plumbing fixtures, fittings and appurtenances shall conform to the standards specified in this section and shall be provided with an adequate supply of potable water to flush and keep the fixtures in a clean and sanitary condition without danger of backflow or cross-connection.

402.3 Water Efficiency Standards.

402.3.1 Standards for Vitreous China Plumbing Fixtures.

402.3.1.1 The following standards shall be adopted as plumbing materials, performance standards, and labeling standards for water closets and urinals. Water closets and urinals shall meet either the ANSI/ASME standards or the CSA standard.

ANSI/ASME A112.19.2M-1998	Vitreous China Plumbing Fixtures
ANSI/ASME A112.19.6-1995	Hydraulic Requirements for Water Closets and Urinals
CSA B45	CSA Standards on Plumbing Fixtures

402.3.1.2 The maximum water use allowed in gallons per flush (gpf) or liters per flush (lpf) for any of the following water closets shall be the following:

Tank-type toilets	1.6 gpf/6.0 lpf
Flushometer-valve toilets	1.6 gpf/6.0 lpf
Flushometer-tank toilets	1.6 gpf/6.0 lpf
Electromechanical hydraulic toilets	1.6 gpf/6.0 lpf

EXCEPTIONS: 1. Water closets located in day care centers, intended for use by young children may have a maximum water use of 3.5 gallons per flush or 13.25 liters per flush.

2. Water closets with bed pan washers may have a maximum water use of 3.5 gallons per flush or 13.25 liters per flush.

3. Blow out bowls, as defined in ANSI/ASME A112.19.2M, Section 5.1.2.3 may have a maximum water use of 3.5 gallons per flush or 13.25 liters per flush.

402.3.1.3 The maximum water use allowed for any urinal shall be 1.0 gallons per flush or 3.78 liters per flush.

402.3.1.4 No urinal or water closet that operates on a continuous flow or continuous flush basis shall be permitted.

402.3.1.5 This section does not apply to fixtures installed before the effective date of this Section, that are removed and relocated to another room or area of the same building after the effective date of this Section.

402.3.2 Standards for Plumbing Fixture Fittings.

402.3.2.1 The following standards are adopted as plumbing material, performance requirements, and labeling standards for plumbing fixture fittings. Faucets, aerators, and shower heads shall meet either the ANSI/ASME standard or the CSA standard.

ANSI/ASME A112.18.1M-1996	Plumbing Fixture Fittings
CSA B125	Plumbing Fittings

402.3.2.2 The maximum water use allowed for any shower head is 2.5 gallons per minute or 9.5 liters per minute.

EXCEPTION: Emergency use showers shall be exempt from the maximum water usage rates.

402.3.2.3 The maximum water use allowed in gallons per minute (gpm) or liters per minute (lpm) for any of the following faucets and replacement aerators is the following:

Lavatory faucets	2.5 gpm/9.5 lpm
Kitchen faucets	2.5 gpm/9.5 lpm
Replacement aerators	2.5 gpm/9.5 lpm
Public lavatory faucets other than metering	0.5 gpm/1.9 lpm

402.4 Metering Valves. Lavatory faucets located in restrooms intended for use by the general public shall be equipped with a metering valve designed to close by spring or water pressure when left unattended (self-closing).

EXCEPTIONS: 1. Where designed and installed for use by persons with a disability.
2. Where installed in day care centers, for use primarily by children under 6 years of age.

402.5 Implementation.

402.5.1 The standards for water efficiency and labeling contained within Section 402.3 shall be in effect as of July 1, 1993, as provided in RCW 19.27.170 and amended July 1, 1998.

402.5.2 No individual, public or private corporation, firm, political subdivision, government agency, or other legal entity, may, for purposes of use in the state of Washington, distribute, sell, offer for sale, import, install, or approve for installation any plumbing fixtures or fittings unless the fix-

tures or fittings meet the standards as provided for in this Section.

Sections 402.6 through 402.9 are not adopted.

412.2 Location of Floor Drains. Floor drains shall be installed in the following areas:

412.2.1 Toilet rooms containing two (2) or more water closets or a combination of one (1) water closet and one (1) urinal, except in a dwelling unit. The floor shall slope toward the floor drains.

412.2.2 Laundry rooms in commercial buildings and common laundry facilities in multi-family dwelling buildings.

413.0 Minimum Number of Required Fixtures. For minimum number of plumbing fixtures required, see Building Code chapter 29 and Table 29-A.

Sections 413.1 through 413.7 and Table 4-1 are not adopted.

[Statutory Authority: RCW 19.27.031, 19.27.074. 02-01-114, § 51-56-0400, filed 12/18/01, effective 7/1/02.]

WAC 51-56-0500 Chapter 5—Water heaters.

501.0 General. The regulations of this chapter shall govern the construction, location, and installation of fuel burning and other water heaters heating potable water. The minimum capacity for water heaters shall be in accordance with the first hour rating listed in Table 5-1. See the Mechanical Code for combustion air and installation of all vents and their connectors. All design, construction, and workmanship shall be in conformity with accepted engineering practices, manufacturer's installation instructions, and applicable standards and shall be of such character as to secure the results sought to be obtained by this Code. No water heater shall be hereinafter installed which does not comply in all respects with the type and model of each size thereof approved by the administrative authority. A list of accepted gas equipment standards is included in Table 14-1.

Water heaters used for space heating only are prohibited.

TABLE 5-1^{1,3}

Number of Bathrooms	1 to 1.5			2 to 2.5				3 to 3.5			
	1	2	3	2	3	4	5	3	4	5	6
Number of Bedrooms											
First Hour Rating ² , Gallons	42	54	54	54	67	67	80	67	80	80	80

- Notes: ¹The first hour rating is found on the "Energy Guide" label.
- ²Nonstorage and solar water heaters shall be sized to meet the appropriate first hour rating as shown in the table.
- ³For replacement water heaters, see Section 101.4.1.1.1.

- 502.1 Chimney** – Delete definition.
- 502.2 Chimney Connector** – Delete definition.
- 502.5 Direct Vent Appliance** – Delete definition.
- 502.7 Unusually Tight Construction** – Delete definition.
- 502.8 Vent** – Delete definition.
- 502.9 Vent Collar** – Delete definition
- 502.10 Vent Connector** – Delete definition.
- 502.11 Venting System** – Delete definition.
- 502.12 Venting Systems-Types** – Delete definition.
- 504.1 Inspection of Chimneys or Vents.** Delete paragraph.
- 505.0 Gas-Fired Water Heater Approval Requirements.**

505.1 Gas fired water heaters shall conform to approved recognized applicable standards or to other standards acceptable to the administrative authority. Each such water heater shall bear the label of an approved testing agency, certifying and attesting that such equipment has been tested and inspected and meets the requirements of applicable standards.

505.2 Except when reconditioned by the manufacturer or the manufacturer's approved agent in accordance with its original approval requirements and reinstalled at its original location, each reconditioned water heater shall be tested for safety and conformity to approved standards, and shall bear the label of an approved testing agency certifying and attesting that such

equipment has been tested and inspected and meets the requirements of applicable standards. Such label shall also state clearly that the water heater has been reconditioned, and shall give the name and address of the reconditioner. Every person applying for a permit to install a used or reconditioned water heater shall clearly state on the application for permit that such equipment is used or reconditioned.

505.3 Gas storage-type water heaters shall be provided with, in addition to the primary temperature controls, an over-temperature safety protection device constructed, listed, and installed in accordance with nationally recognized applicable standards for such devices and a combination temperature and pressure relief valve.

506.2 All storage-type water heaters deriving heat from fuels or types of energy other than gas, shall be provided with, in addition to the primary temperature controls, an over-temperature safety protection device constructed, listed, and installed in accordance with nationally recognized applicable standards for such devices and a combination temperature and pressure relief valve.

507.0 Combustion Air. For issues relating to combustion air, see the Mechanical Code.

Sections 507.1 through 507.5 are not adopted.

509.0 Prohibited Locations. Water heaters which depend on the combustion of fuel for heat shall not be installed in a room used or designed to be used for sleeping purposes, bathroom, clothes closets or in a closet or other confined space opening into a bath or bedroom.

- EXCEPTIONS:
- 1. Direct vent water heaters.
 - 2. Water heaters installed in a closet that has a weather-stripped solid door with an approved door closing device, and designed exclusively for the water

heater and where all air for combustion and ventilation is supplied from the outdoors.

3. Water heaters of the automatic storage type installed as a replacement in a bathroom, when specifically approved, properly vented and supplied with adequate combustion air.

Where not prohibited by other regulations, water heaters may be located under a stairway or landing.

512.0 Venting of Water Heaters. Delete entire section.

513.0 Limitations. Delete entire section.

514.0 Vent Connectors. Delete entire section.

515.0 Location and Support of Venting System. Delete entire section.

516.0 Length Pitch and Clearance. Delete entire section.

517.0 Vent Termination. Delete entire section.

518.0 Area of Venting System. Delete entire section.

519.0 Multiple Appliance Venting. Delete entire section.

520.0 Existing Venting System. Delete entire section.

521.0 Draft Hoods. Delete entire section.

522.0 Gas Venting into Existing Masonry Chimneys. Delete entire section.

523.0 Chimney Connectors. Delete entire section.

524.0 Mechanical Draft Systems. Delete entire section.

525.0 Venting Through Ventilating Hoods and Exhaust Systems. Delete entire section.

[Statutory Authority: RCW 19.27.031, 19.27.074. 02-01-114, § 51-56-0500, filed 12/18/01, effective 7/1/02.]

WAC 51-56-0600 Chapter 6—Water supply and distribution.

603.0 Cross-Connection Control. Cross-connection control shall be provided in accordance with the provisions of this chapter. Devices or assemblies for protection of the public water system must be models approved by the department of health under WAC 246-290-490. The administrative authority shall coordinate with the local water purveyor where applicable in all matters concerning cross-connection control within the property lines of the premises.

No person shall install any water operated equipment or mechanism, or use any water treating chemical or substance, if it is found that such equipment, mechanism, chemical or substance may cause pollution or contamination of the domestic water supply. Such equipment or mechanism may be permitted only when equipped with an approved backflow prevention device or assembly.

603.3.3 For devices and assemblies other than those regulated by the Washington department of health in conjunction with the local water purveyor for the protection of public water systems, the administrative authority shall ensure that the premise owner or responsible person shall have the back-

flow prevention assembly tested by a Washington state department of health certified backflow assembly tester:

- (1) At the time of installation, repair or relocation; and
- (2) At least on an annual schedule thereafter, unless more frequent testing is required by the administrative authority.

603.4.6.1 Potable water supplies to systems having no pumps or connections for pumping equipment, and no chemical injection or provisions for chemical injection, shall be protected from backflow by one of the following devices:

- (1) Atmospheric vacuum breaker.
- (2) Pressure vacuum breaker.
- (3) Reduced pressure backflow preventer.
- (4) A double check valve may be allowed when approved by the water purveyor and the administrative authority.
- (5) A spill proof pressure vacuum breaker may be allowed when approved by the water purveyor and the administrative authority.

603.4.13 Potable Water Supply to Carbonators shall be protected by a listed reduced pressure principle backflow preventer as approved by the administrative authority for the specific use.

603.4.18.1 Except as provided under Sections 603.4.18.2 and 603.4.18.3, potable water supplies to fire protection systems that are normally under pressure, including but not limited to standpipes and automatic sprinkler systems, except in one or two family residential flow-through or combination sprinkler systems piped in materials approved for potable water distribution systems, shall be protected from back-pressure and back-siphonage by one of the following testable devices:

1. Double check valve assembly.
2. Double check detector assembly.
3. Reduced pressure backflow preventer.
4. Reduced pressure detector assembly.

Potable water supplies to fire protection systems that are not normally under pressure shall be protected from backflow and shall meet the requirements of the appropriate standard(s) referenced in Table 14-1.

604.1 Water distribution pipe, building supply water pipe and fittings shall be of brass, copper, cast iron, galvanized malleable iron, galvanized wrought iron, galvanized steel or other approved materials. Except as provided in Section 604.13, asbestos-cement, CPVC, PE, PVC, or PEX water pipe materials manufactured to recognized standards may be used for cold water distribution systems outside a building. CPVC, PEX water pipe, tubing, and fittings, manufactured to recognized standards may be used for hot and cold water distribution systems within a building. Other products not listed in this section are acceptable for their intended use, provided that such materials or distribution systems are listed and approved in accordance with nationally recognized standards. All materials used in the water supply system, except valves and similar devices shall be of like material, except where otherwise approved by the administrative authority.

604.13 Plastic water service piping may terminate within a building, provided the connection to the potable water distri-

bution system shall be made as near as is practical to the point of entry and shall be accessible. Barbed insert fittings with hose clamps are prohibited as a transition fitting within the building.

608.5 Relief valves located inside a building shall be provided with a drain, not smaller than the relief valve outlet, of galvanized steel, hard drawn copper piping and fittings, CPVC, or listed relief valve drain tube with fittings which will not reduce the internal bore of the pipe or tubing (straight lengths as opposed to coils) and shall extend from the valve to the outside of the building with the end of the pipe not more than two (2) feet (610 mm) nor less than six (6) inches (152 mm) above the ground or the flood level of the area receiving the discharge and pointing downward. Such drains may terminate at other approved locations. No part of such drain pipe shall be trapped or subject to freezing. The terminal end of the drain pipe shall not be threaded.

EXCEPTION: Replacement water heating equipment shall only be required to provide a drain pointing downward from the relief valve to extend between two feet (610 mm) and six inches (152 mm) from the floor. No additional floor drain need be provided.

610.4 Systems within the range of Table 6-5 may be sized from that table or by the method set forth in Section 610.5.

Listed parallel water distribution systems shall be installed in accordance with their listing.

[Statutory Authority: RCW 19.27.031, 19.27.074. 02-01-114, § 51-56-0600, filed 12/18/01, effective 7/1/02.]

WAC 51-56-0700 Chapter 7—Sanitary drainage.

701.1.2 ABS and PVC DWV piping installations shall be installed in accordance with IS 5, IS 9, and Appendix M "Firestop Protection for DWV and Stormwater Application." Except for individual single family dwelling units, materials exposed within ducts or plenums shall have a flame-spread index of not more than 25 and a smoke developed index of not more than 50, when tested in accordance with the Test for Surface-Burning Characteristics of the Building Materials (See the Building Code standards based on ASTM E-84 and ANSI/UL 723).

704.3 Delete entire section.

710.3 The minimum size of any pump or any discharge pipe from a sump having a water closet connected thereto shall be not less than two (2) inches (52 mm).

Sections 710.3.1 through 710.3.3 are not adopted.

CHAPTER 7, PART II—BUILDING SEWERS

Part II Building Sewers. Delete all of Part II (Sections 713 through 723, and Tables 7-7 and 7-8).

[Statutory Authority: RCW 19.27.031, 19.27.074. 02-01-114, § 51-56-0700, filed 12/18/01, effective 7/1/02.]

WAC 51-56-0800 Chapter 8—Indirect wastes.

810.4 Strainers. Every indirect waste interceptor receiving discharge containing particles that would clog the receptor drain shall have a readily removable dome strainer.

(2003 Ed.)

[Statutory Authority: RCW 19.27.031, 19.27.074. 02-01-114, § 51-56-0800, filed 12/18/01, effective 7/1/02.]

WAC 51-56-0900 Chapter 9—Vents.

903.1.2 ABS and PVC DWV piping installations shall be installed in accordance with IS 5, IS 9, and Appendix M "Firestop Protection for DWV and Stormwater Application." Except for individual single family dwelling units, materials exposed within ducts or plenums shall have a flame-spread index of not more than 25 and a smoke developed index of not more than 50, when tested in accordance with the Test for Surface-Burning Characteristics of the Building Materials (see the Building Code standards based on ASTM E-84 and ANSI/UL 723).

[Statutory Authority: RCW 19.27.031, 19.27.074. 02-01-114, § 51-56-0900, filed 12/18/01, effective 7/1/02.]

WAC 51-56-1300 Chapter 13—Health care facilities and medical gas and vacuum systems.

1302 Medical Gas and Vacuum Piping Systems.

The installation of medical gas and vacuum piping systems shall be in accordance with the requirements of this chapter and/or the appropriate standards adopted by the administrative authority, for additional standards see Table 14-1. The administrative authority shall require evidence of the competency of the installers.

Part II Medical Gas and Vacuum Systems

1309.0 Scope.

1309.1 The provisions herein shall apply to the design, installation, testing, and verification of medical gas, medical vacuum systems, and related permanent equipment for safe use in patient care hospitals, clinics, and other health care facilities.

1309.2 The purpose of this chapter is to provide minimum requirements for the design, installation and verification of medical gas, medical vacuum systems, and related permanent equipment

1310.0 Definitions.

1310.1 Building Supply – The pipe from the source of supply to a building or structure.

1310.2 Critical Care Area – An area in a medical facility where special care is provided, including intensive care units, coronary care units, recovery rooms, and respiratory care units.

1310.3 Installer Performance Testing – Testing conducted by the installer or representative prior to system verification using oil-free, dry nitrogen as stated in Chapter 14.

1310.4 Manifold – A device for connecting outlets of one or more gas cylinders to the central piping system for that specific gas.

1310.5 Medical Air – Compressed air used in a medical facility.

[Title 51 WAC—p. 225]

1310.6 Medical Gas – Gases used in a medical facility, including oxygen, nitrous oxide, nitrogen, carbon dioxide, helium, medical air, and mixtures of these gases. Standards of purity apply.

1310.7 Medical Gas System – A system consisting of a central supply system (manifold, bulk, or compressors), including control equipment and piping extending to station outlets in the facility where medical gases may be required.

1310.8 Medical Vacuum System – A system consisting of central vacuum-producing equipment with vacuum switches and operating controls, shutoff valves, alarm warning systems, gauges, and a network of piping extending to and terminating with station inlets at locations where patient suction may be required. Includes surgical vacuum systems, waste anesthesia gas disposal (as scavenging systems), and bedside suction systems.

1310.9 Purge, Flow – The removal of oxygen from a system by oil-free dry nitrogen during brazing.

1310.10 Purge, System – The removal of nitrogen from a system with the medical gas required for that system.

1310.11 SCFM – Standard cubic feet per minute, the unit measure for a volume of gas at standard conditions (68 degrees F (20 degrees C) and 1 atmosphere of pressure).

1310.12 Special Hazard Area – An area, such as a kitchen or electrical switch gear room.

1310.13 Station Inlet – An inlet in a vacuum piping system at which the user makes connections and disconnections.

1310.14 Station Outlet – An outlet point in a medical gas piping system at which the user makes connections and disconnections.

1310.15 System Verification – Testing conducted by a qualified party other than the installer or material vendor after the installer performance testing and prior to the medical gas system being put into service.

1310.16 Use Point – A room or area within a room, where medical gases are dispensed to a patient for medical purposes.

1310.17 User Outlet – See station outlet.

1310.18 Valve, Isolation – A valve which isolates one piece of equipment from another.

1310.19 Valve, Riser – A valve at the base of a vertical riser, which isolates that riser.

1310.20 Valve, Service – A valve serving horizontal piping extending from a riser to a station outlet or inlet.

1310.21 Valve, Source – A single valve at the source which controls a number of units that make up the total source.

1310.22 Valve, Zone – A valve which controls the gas or vacuum to a particular area.

1311.3 The administrative authority shall require evidence of the competency of the installers.

1311.4 Delete paragraph.

1313.0 System Installation and Installer Performance Testing.

1313.1 Medical gas and medical vacuum systems shall be designed and installed in accordance with the requirements of this chapter and the installation requirements of this code, specifically Chapter 14 of this code.

1313.2 A report of completion of the installer performance testing which includes the specific items in Chapter 14 shall be furnished to the administrative authority prior to system verification.

1314.0 System Verification.

1314.1 Prior to any medical gas system being placed in service, each and every system shall be verified as described in Chapter 14. This verification shall be accomplished by an independent third party verification agency which is approved by the administrative authority.

1314.2 A report which includes at least the specific items in Chapter 14 shall be furnished to the administrative authority prior to final acceptance of the system.

Sections 1315 through 1331 are not adopted.

[Statutory Authority: RCW 19.27.031, 19.27.074. 02-01-114, § 51-56-1300, filed 12/18/01, effective 7/1/02.]

WAC 51-56-1400 Chapter 14—Referenced standards.

TABLE 14-1
Standards for Materials, Equipment, Joints and Connections

Where more than one standard has been listed for the same material or method, the relevant portions of all such standards shall apply.

Standard Number	Standard Title	Application	Indicate if Not Approved in the UPC
AHAM DW-1-92	Household Electric Dishwashers	Appliances	
AHAM DW-2PR-86	Plumbing Requirements for Household Dishwashers	Appliances	
AHAM FWD-1-83	Food Waste Disposers	Appliances	

Standard Number	Standard Title	Application	Indicate if Not Approved in the UPC
AHAM HLW-2 PR-86	Plumbing Requirements for Home Laundry Equipment Appliances		
ANSI A13.1-81(R93)	Scheme for the Identification of Piping Systems		
ANSI A21.10-93	Piping	Piping, Ferrous	
ANSI A21.11-90	Ductile-Iron and Gray-Iron Fittings, 3 in. Through 48 in. (75 mm Through 1200 mm), for Water and Other Liquids (same as AWWA C110)	Piping, Ferrous	
ANSI A21.51-91	Rubber-Gasket Joints for Ductile-Iron Pressure Pipe and Fittings (same as AWWA C111)	Piping, Ferrous	
ANSI A21.53-88	Ductile-Iron Pipe, Centrifugally Cast, for Water (same as AWWA C151)	Piping, Ferrous	
ANSI A40.3-93	Ductile-Iron Compact Fittings, 3 in. Through 24 in. (76 mm Through 610 mm) and 54 in. Through 64 in. (1,400 mm Through 1,600 mm), for Water Service (same as AWWA C153)	Piping, Ferrous	
ANSI A106.6-70	Stainless steel	Piping, Nonmetallic	
ANSI A106.6-77	Vitrified Clay Pipe (now CSA A60.1M1976(C1992))	Joints	
ANSI A112.14.1-75 (R90)	Silver brazing joints for wrought and cast bronze solder joint fittings	Valves	
ANSI A112.19.5-79	Backwater Valves	Fixtures	
ANSI A112.21.2M-83	Trim for Water-Closet Bowls, Tanks and Urinals	DWV Components	
ANSI A118.10-93	Roof Drains	Fixtures	
ANSI B2.1-90	Load Bearing, Bonded, Waterproof Membranes for Thin-Set Ceramic Tile and Dimension Stone Installations	Joints	
ANSI B125.1-84	Pipe Threads (Except Dryseal) (replaced by ASME B1.20.1-98)	Piping, Ferrous	
ANSI B125.2-72	Steel pipe (galvanized)	Piping, Ferrous	
ANSI Z21.10.1a-94	Steel pipe (galvanized)	Appliances	
ANSI Z21.10.1b-92	Gas Water Heaters - Volume I - Storage Water Heaters with Input Ratings of 75,000 BTU per Hour or Less (22 kW)	Appliances	
ANSI Z21.10.3-90	Gas Water Heaters - Volume I - Storage Water Heaters with Input Ratings of 75,000 BTU per Hour or Less (22 kW)	Appliances	
ANSI Z21.10.3a-94	Gas Water Heaters - Volume III - Storage, with Input Ratings Above 75,000 Btu per Hour, Circulating and Instantaneous Water Heaters	Appliances	
ANSI Z21.10.3b-92	"	Appliances	
ANSI Z21.12-90	"	Appliances	
ANSI Z21.13-91	Draft Hoods	Appliances	
ANSI Z21.15-92	Gas-Fired Low-Pressure Steam and Hot Water Boilers and Addenda	Appliances	
ANSI Z21.22a-90	Manually Operated Gas Valves for Appliances, Appliance Connector Valves and Hose End Valves	Valves	
ANSI Z21.24-93	Relief Valves and Automatic Gas Shutoff Devices for Hot Water Supply Systems	Valves	
ANSI Z21.41-89	Metal Connectors for Gas Appliances	Appliances	
ANSI Z21.56-98	Quick-Disconnect Devices for Use with Gas Fuel	Joints	
ANSI Z21.69-1997•CSA 6.16-M97	Gas Fired Pool Heaters	Swimming Pools and Spas	
ANSI Z21.70-81	Connectors for Moveable Gas Appliances	Appliances	
	Earthquake Actuated Automatic Gas Shutoff Systems (withdrawn from ANSI June, 1992)	Valves	

Standard Number	Standard Title	Application	Indicate if Not Approved in the UPC
ANSI Z21.80-1997•CSA 6.22-M97	Line Pressure Regulators	Fuel Gas	
ANSI Z21.81-1997•CSA 6.25-M97	Cylinder Connection Devices	Fuel Gas	
ANSI Z21.86•CSA 2.32-M98 ANSI Z34.1-93	Vented Gas-Fired Space Heating Appliances Certification - Third Party Certification Programs for Products, Processes, and Services	Appliances Certification	
ANSI Z124.1-95	Plastic Bathtub Units	Fixtures	
ANSI Z124.2-95	Plastic Shower Receptors and Shower Stalls	Fixtures	
ANSI Z124.3-95	Plastic Lavatories	Fixtures	
ANSI Z124.4-96	Plastic Water Closet Bowls and Tanks	Fixtures	
ANSI Z124.5-97	Plastic Toilet (Water Closet) Seats	Fixtures	
ANSI Z124.6-97	Plastic Sinks	Fixtures	
ANSI Z124.7-97	Prefabricated Plastic Spa Shells	Fixtures	
ANSI Z124.8-90	Plastic Bathtub Liners	Fixtures	
ANSI Z124.9-94	Plastic Urinal Fixtures (Note 1)	Fixtures	
ANSI Z223.1-99	National Fuel Gas Code	Fuel Gas	
ARI 1010-84	Drinking-Fountains and Self-Contained, Mechanically-Refrigerated Drinking Water Coolers	Appliances	
ASHRAE 90.1-89	Energy Efficient Design of New Buildings Except Low-Rise Residential Buildings	Miscellaneous	
ASME A112.1.2-96	Air Gaps in Plumbing Systems	Piping	
ASME A112.3.1-93	Stainless Steel Drainage Systems for Sanitary Storm and Chemical Application, Above and Below Ground (Note 1)	Piping, Ferrous	X
ASME A112.4.1-93	Water Heater Relief Valve Drain Tubes	Appliances	
ASME A112.6.1M-97	Floor-Affixed Supports for Off-the-Floor Plumbing Fixtures for Public Use	Fixtures	
ASME A112.18.1M-96	Plumbing Fixture Fittings	Valves	
ASME A112.18.6-99	Flexible Water Connectors	Piping	
ASME A112.18.3-96	Performance Requirements for Backflow Protection Devices and Systems in Plumbing Fixture Fittings (Note 8)	Valves	
ASME A112.19.1M-94	Enameled Cast Iron Plumbing Fixtures (Supplement 1-1998)	Fixtures	
ASME A112.19.2M-98	Vitreous China Plumbing Fixtures	Fixtures	
ASME A112.19.3M-87	Stainless Steel Plumbing Fixtures (Designed for Residential Use)	Fixtures	
ASME A112.19.4M-94	Porcelain Enameled Formed Steel Plumbing Fixtures (Supplement 1-1998)	Fixtures	
ASME A112.19.6-95	Hydraulic Performance Requirements for Water Closets and Urinals	Fixtures	
ASME A112.19.7M-95	Whirlpool Bathtub Appliances	Fixtures	
ASME A112.19.8M-87	Suction Fittings for Use in Swimming Pools, Wading Pools, Spas, Hot Tubs, and Whirlpool Bathtub Appliances	Swimming Pools and Spas	
ASME A112.19.9M-91	Nonvitreous Ceramic Plumbing Fixtures	Fixtures	
ASME A112.21.1M-91	Floor Drains (Note 1)	DWV Components	
ASME A112.21.3M-85	Hydrants for Utility and Maintenance Use (Note 1)	Valves	
ASME A112.26.1M-84	Water Hammer Arresters	Piping	
ASME A112.36.2M-91	Cleanouts (Note 1)	DWV Components	
ASME B1.20.1-83 (R1992)	Pipe Threads, General Purpose (Inch)	Joints	
ASME B1.20.3-76 (R82/91/98)	Dryseal Pipe Threads, Inch	Joints	
ASME B16.1-89	Cast Iron Pipe Flanges and Flanged Fittings, Class 25, 125, 250, and 800	Piping, Ferrous	

Standard Number	Standard Title	Application	Indicate if Not Approved in the UPC
ASME B16.3-92	Malleable-Iron Threaded Fittings	Piping, Ferrous	
ASME B16.4-92	Gray Iron Threaded Fittings (includes Revision Services)	Piping, Ferrous	
ASME B16.5-88	Pipe Flanges and Flanged Fittings	Joints	
ASME B16.12-91	Iron Threaded Drainage Fittings (Note 1)	Piping, Ferrous	
ASME B16.15-85 (R1994)	Cast Bronze Threaded Fittings, Classes 125 and 250	Piping, Copper Alloy	
ASME B16.18-84	Cast Copper Alloy Solder Joint Pressure Fittings (Note 1)	Piping, Copper Alloy	
ASME B16.21-92	Nonmetallic Flat Gaskets for Pipe Flanges	Joints	
ASME B16.22-95	Wrought Copper and Copper Alloy Solder-Joint Pressure Fittings Alloy	Piping, Copper	
ASME B16.23-92	Cast Copper Alloy Solder Joint Drainage Fittings - DWV Alloy	Piping, Copper	
ASME B16.24-91	Cast Copper Alloy Pipe Flanges and Flanged Fittings Alloy	Piping, Copper	
ASME B16.26-88	Cast copper alloy fittings for flared copper tubes Alloy	Piping, Copper	
ASME B16.29-86	Wrought Copper and Wrought Copper Alloy Solder Joint Drainage Fittings-DWV Alloy (Note 1)	Piping, Copper	
ASME B16.32-92	Cast Copper Alloy Solder Joint Fittings for Solvent Drainage Systems Alloy	Piping, Copper	
ASME B16.33-90	Manually Operated Metallic Gas Valves for Use in Gas Piping Systems up to 125 psig.	Valves	
ASME B16.34-88	Valves - Flanged, Threaded and Welding End	Valves	
ASME B16.38-85	Large Metallic Valves for Gas Distribution (Manually Operated, NPS 2-1/2 to 12, 125 psig Maximum)	Valves	
ASME B16.39-86	Pipe Unions, Malleable Iron Threaded (Includes Revision (R1994) Services)	Piping, Ferrous	
ASME B16.47-90	Large Diameter Steel Flanges	Piping, Ferrous	
ASME B36.10M-85	Welded and Seamless Wrought Steel Pipe	Piping, Ferrous	
ASME Section IX	Welding and Brazing Procedures, Welders, Brazers, and Welding and Brazing Operators	Certification	
ASSE 1001-90	Pipe Applied Atmospheric-Type Vacuum Breakers	Backflow Protection	
ASSE 1002-86	Water Closet Flush Tank Ballcocks	Backflow Protection	
ASSE 1003-95	Water Pressure Reducing Valves for Domestic Water Supply Systems	Valves	
ASSE 1004-90	Backflow Prevention Requirements for Commercial Dishwashing Machines	Backflow Protection	
ASSE 1006-89	Residential Use Dishwashers	Appliances	
ASSE 1007-92	Home Laundry Equipment	Appliances	
ASSE 1008-89	Household Food Waste Disposer Units	Appliances	
ASSE 1009-90	Commercial Food Waste Grinder Units	Appliances	
ASSE 1010-98	Performance Requirements for Water Hammer Arrestors	Piping	
ASSE 1011-95	Hose-Connection Vacuum Breakers	Backflow Protection	
ASSE 1013-93	Reduced Pressure Principle Backflow Preventers	Backflow Protection	
ASSE 1014-90	Hand-Held Showers	Fixtures	
ASSE 1015-93	Double Check Backflow Prevention Assembly	Backflow Protection	
ASSE 1016-96	Individual, Thermostatic Pressure Balancing and Thermostatic Control Valves for Individual Fixtures	Valves	
ASSE 1017-86	Thermostatic Mixing Valves, Self Actuated for Primary Domestic Use	Valves	
ASSE 1018-86	Trap Seal Primer Valves (water supply fed)	Valves	

Standard Number	Standard Title	Application	Indicate if Not Approved in the UPC
ASSE 1019-95	Performance Requirements for Vacuum Breaker Wall Hydrant, Freeze Resistant Automatic Draining Type	Backflow Protection	
ASSE 1020-90	Pressure Vacuum Breaker Assembly	Backflow Protection	
ASSE 1021-77	Dishwasher Air Gaps for Domestic Dishwasher Applications	Backflow Protection	
ASSE 1023-79	Hot Water Dispensers Household Storage Type Electrical	Appliances	
ASSE 1025-78	Diverter for Plumbing Faucets with Hose Spray, Anti-Siphon Type, Residential Applications	Valves	
ASSE 1028-81	Automatic Flow Controllers	Valves	
ASSE 1032-80	Dual Check Valve Type Backflow Preventers for Carbonated Beverage Dispensers - Post Mix Types	Backflow Protection	X
ASSE 1034-81	Fixed Flow Restrictors	Piping	
ASSE 1035-95	Laboratory Faucet Backflow Preventer	Backflow Protection	
ASSE 1037-90	Pressurized Flushing Devices (Flushometers) for Plumbing Fixtures	Backflow Protection	
ASSE 1052-94	Hose Connection Backflow Preventers	Backflow Protection	
ASSE 1055-97	Chemical Dispensing Systems	Backflow Protection	
ASSE 1056-95	Back Siphonage Backflow Vacuum Breakers	Backflow Protection	
ASSE 1062-97	Temperature Actuated, Flow Reduction Valves for Individual Fixture Fittings	Valves	
ASSE 1066-97	Individual Pressure Balancing In-Line Valves for Individual Fixture Fittings (Note 9)	Valves	
ASSE 6000-98	Medical Gas Systems Installers, Inspectors and Verifiers	Certification	
ASTM A 47-90 (R95)	Ferritic Malleable Iron Castings	Piping, Ferrous	
ASTM A 53-96 (97)	Pipe, Steel, Black and Hot-Dipped, Zinc-Coated Welded, and Seamless	Piping, Ferrous	
ASTM A 74-98	Cast Iron Soil Pipe and Fittings (Note 1)	Piping, Ferrous	
ASTM A 120-84 [D]	Pipe, Steel, Black and Hot-Dipped, Zinc-Coated, (Galvanized) Welded, and Seamless for Ordinary Uses (replaced by A 53)	Piping, Ferrous	
ASTM A 126-95	Gray Iron Castings for Valves, Flanges, and Pipe Fittings	Piping, Ferrous	
ASTM A 197-87 (R-92)	Cupola Malleable Iron [Metric]	Piping, Ferrous	
ASTM A 312-93	Seamless and Welded Austenitic Stainless Steel Pipes	Piping, Ferrous	
ASTM A 377-95	Ductile-Iron Pressure Pipe	Piping, Ferrous	
ASTM A 518-92 ^{e1}	Corrosion-Resistant High-Silicon Iron Castings [Metric]	Piping, Ferrous	
ASTM A 536-84(R-93)	Ductile Iron Castings	Piping, Ferrous	
ASTM A 653-96	Steel Sheet, Zinc-Coated (Galvanized) or Zinc-Iron Alloy-Coated (Galvannealed) by the Hot-Dip Process	Piping, Ferrous	
ASTM A 733-93	Welded and Seamless Carbon Steel and Austenitic Stainless Steel Pipe Nipples	Piping, Ferrous	
ASTM A 861-94 ^{e1}	High-Silicon Iron Pipe and Fittings (Note 1)	Piping, Ferrous	
ASTM B 29-92	Pig Lead	Joints	
ASTM B 32-96	Solder Metal (Note 4)	Joints	
ASTM B 42-96	Seamless Copper Pipe, Standards Sizes	Piping, Copper Alloy	
ASTM B 43-96	Seamless Red Brass Pipe, Standards Sizes	Piping, Copper Alloy	
ASTM B 75-95a	Seamless Copper Tube	Piping, Copper Alloy	

Standard Number	Standard Title	Application	Indicate if Not Approved in the UPC
ASTM B 88-96	Seamless Copper Water Tube	Piping, Copper Alloy	
ASTM B 135-96	Seamless Brass Tube	Piping, Copper Alloy	
ASTM B 152-97	Copper Sheet, Strip, Plate, and Rolled Bar	Miscellaneous	
ASTM B 251-97	General Requirements for Wrought Seamless Copper Alloy Tube	Piping, Copper Alloy	
ASTM B 280-95a	Seamless Copper Tube for Air Conditioning and Refrigeration Field Service	Piping, Copper Alloy	
ASTM B 302-97	Threadless Copper Pipe	Piping, Copper Alloy	
ASTM B 306-96	Copper Drainage Tube (DWV)	Piping, Copper Alloy	
ASTM B 370-92 ¹	Copper Sheet and Strip for Building Construction	Miscellaneous	
ASTM B 447-97	Welded Copper Tube	Piping, Copper Alloy	
ASTM B 584-96	Copper Alloy Sand Casting for General Applications (Note 5)	Piping, Copper Alloy	
ASTM B 587-96	Welded Brass Tube	Piping, Copper Alloy	
ASTM B 641-93	Seamless and Welded Copper Distribution Tube (Type D)	Piping, Copper Alloy	
ASTM B 642-88 [D]	Welded Copper Alloy UNS C21000 Water Tube (discontinued 1994)	Piping, Copper Alloy	
ASTM B 687-96	Brass, Copper, and Chromium-Plated Pipe Nipples	Piping, Copper Alloy	
ASTM B 716-93 [D]	Welded Copper Water Tube (discontinued 1994)	Piping, Copper Alloy	
ASTM B 813-93	Liquid and Paste Fluxes for Soldering Applications of Copper and Copper Alloy Tube	Joints	
ASTM B 819-95	Seamless Copper Tube for Medical Gas Systems	Piping, Copper Alloy	
ASTM B 828-92 ¹	Making Capillary Joints by Soldering of Copper and Copper Alloy Tube and Fittings	Joints	
ASTM C 14-95	Concrete Sewer, Storm Drain and Culvert Pipe	Piping, Nonmetallic	
ASTM C 296-93	Asbestos-Cement Pressure Pipe	Piping, Nonmetallic	
ASTM C 412-94	Concrete Drain Tile	Piping, Nonmetallic	
ASTM C 425-96	Compression Joints for Vitrified Clay Pipe and Fittings	Joints	
ASTM C 428-92	Asbestos-Cement Nonpressure Sewer Pipe (Notes 6 & 7)	Piping, Nonmetallic	
ASTM C 443-94	Joints for Circular Concrete Sewer and Culvert Pipe, Using Rubber Gaskets	Joints	
ASTM C 478-96	Precast Reinforced Concrete Manholes Sections	Miscellaneous	
ASTM C 564-95a	Rubber Gaskets for Cast Iron Soil Pipe and Fittings (Note 1)	Joints	
ASTM C 700-96	Vitrified Clay Pipe, Extra Strength, Standard Strength, and Perforated	Piping, Nonmetallic	
ASTM C 1053-90 (R95)	Borosilicate Glass Pipe and Fittings for Drain, Waste and Vent (DWV) Applications (Note 1)	Piping, Nonmetallic	
ASTM C 1173-95	Flexible Transition Couplings for Underground Piping Systems	Joints	
ASTM C 1277-94	Shielded Couplings Joining Hubless Cast Iron Soil Pipe and Fittings	Piping, Ferrous	
ASTM D 396-97	Specification for Fuel Oil	Miscellaneous	
ASTM D 1527-96a	Acrylonitrile-Butadiene-Styrene (ABS) Plastic Pipe Sch. 40 and 80	Piping, Plastic	

Standard Number	Standard Title	Application	Indicate if Not Approved in the UPC
ASTM D 1785-96a ¹	Poly (Vinyl Chloride) (PVC) Plastic Pipe Sch. 40, 80 and 120	Piping, Plastic	
ASTM D 1869-95	Rubber O-rings for Asbestos-Cement Pipe	Joints	
ASTM D 2104-95	Polyethylene (PE) Plastic Pipe, Sch. 40	Piping, Plastic	
ASTM D 2146-82 [D]	Polypropylene Plastic Molding and Extrusion Materials (replaced by ASTM D 4101)	Piping, Plastic	
ASTM D 2235-96a	Solvent Cement for Acrylonitrile-Butadiene-Styrene (ABS) plastic pipe and fittings	Joints	
ASTM D 2239-96a	Polyethylene (PE) Plastic Pipe, (SDR-PR) Based on Controlled Inside Diameter	Piping, Plastic	
ASTM D 2241-96a	Poly(Vinyl Chloride) (PVC) Pressure-Rated pipe (SDR Series)	Piping, Plastic	
ASTM D 2282-96a	Acrylonitrile-Butadiene-Styrene (ABS) Plastic Pipe (SDR-PR)	Piping, Plastic	
ASTM D 2321-89 (R95)	Underground Installation of Thermoplastic Pipe for Sewers and Other Gravity-Flow Applications	Piping, Plastic	
ASTM D 2447-95	Polyethylene (PE) Plastic Pipe, Sch. 40 and 80 Based on Controlled Outside Diameter	Piping, Plastic	
ASTM D 2464-96a	Threaded Poly(Vinyl Chloride) (PVC) Plastic Pipe Fittings, Sch. 80 (Note 1)	Piping, Plastic	
ASTM D 2465-73[D]	Threaded Acrylonitrile-Butadiene-Styrene (ABS) Plastic Pipe Fittings, Schedule 80 (discontinued 1986)	Piping, Plastic	
ASTM D 2466-96a	Poly(Vinyl Chloride) (PVC) Plastic Pipe Fittings, Sch. 40 (Note 1)	Piping, Plastic	
ASTM D 2467-96a	Poly(Vinyl Chloride) (PVC) Plastic Pipe Fittings, Sch, 80 (Note 1)	Piping, Plastic	
ASTM D 2468-96a	Acrylonitrile-Butadiene-Styrene (ABS) Plastic Pipe Fittings (Sch. 40)	Piping, Plastic	
ASTM D 2469-76[D]	Socket-Type Acrylonitrile-Butadiene-Styrene (ABS) Plastic Pipe Fittings, Schedule 80 (discontinued 1986)	Piping, Plastic	
ASTM D 2513-96a	Thermoplastic Gas Pressure Pipe Tubing, and Fittings (Note 1)	Piping, Plastic	
ASTM D 2564-96a	Solvent Cements for Poly(Vinyl Chloride) (PVC) Plastic Piping Systems	Joints	
ASTM D 2609-96a	Plastic Insert Fittings for Polyethylene (PE) Plastic Pipe (Note 1)	Piping, Plastic	
ASTM D 2657-96	Practice for Heating Fusion Joining of Polyolefin Pipe and Fittings	Joints	
ASTM D 2661-96	Acrylonitrile-Butadiene-Styrene (ABS) Sch. 40 Plastic Drain, Waste and Vent Pipe and Fittings (Note 1)	Piping, Plastic	
ASTM D 2665-97a	Poly (Vinyl Chloride) (PVC) Plastic Drain, Waste and Vent Pipe and Fittings	Piping, Plastic	
ASTM D 2672-96a	Joints for IPS PVC Pipe Using Solvent Cement	Joints	
ASTM D 2680-95a	Acrylonitrile-Butadiene-Styrene (ABS) and Poly(Vinyl Chloride) (PVC) Composite Sewer Piping	Piping, Plastic	
ASTM D 2729-96	Poly (Vinyl Chloride) (PVC) Sewer Pipe and Fittings (Note 1)	Piping, Plastic	
ASTM D 2737-96a	Polyethylene (PE) Plastic Tubing	Piping, Plastic	
ASTM D 2740-89 e1 [D]	Poly (Vinyl Chloride) (PVC) Plastic Tubing (discontinued 1991)	Piping, Plastic	
ASTM D 2751-96	Acrylonitrile-Butadiene-Styrene (ABS) Sewer Pipe and Fittings (Note 1)	Piping, Plastic	

Standard Number	Standard Title	Application	Indicate if Not Approved in the UPC
ASTM D 2846-96a	Chlorinated Poly(Vinyl Chloride) (CPVC) Plastic Hot- and Cold-Water Distribution Systems	Piping, Plastic	
ASTM D 2855-96	Making Solvent-Cemented Joints with Poly(Vinyl Chloride) (PVC) Pipe and Fittings	Joints	
ASTM D 2996-95	Filament-Wound Fiberglass (Glass-Fiber-Reinforced Thermosetting Resin) pipe	Piping, Plastic	
ASTM D 3033-85 [D]	Type PSP Poly (Vinyl Chloride) (PVC) Sewer Pipe and Fittings (discontinued 1989)	Piping, Plastic	
ASTM D 3034-96	Type PSM Poly(Vinyl Chloride) (PVC) Sewer Pipe and Fittings	Piping, Plastic	
ASTM D 3036-73[D]	Poly (Vinyl Chloride) (PVC) Plastic Line Couplings (discontinued 1986)	Piping, Plastic	
ASTM D 3065-94	Rigid Acrylonitrile-Butadiene-Styrene (ABS) Materials for Pipe and Fittings	Piping, Plastic	
ASTM D 3122-95	Solvent Cements for Styrene-Rubber (SR) Plastic Pipe and Fittings	Joints	
ASTM D 3139-96a	Joints for Plastic Pressure Pipes Using Flexible Elastomeric Seals	Joints	
ASTM D 3140-90	Flaring Polyolefin Pipe and Tubing	Joints	
ASTM D 3212-96a	Joints for Drain and Sewer Plastic Pipes Using Flexible Elastomeric Seals	Joints	
ASTM D 3298-81 [D]	Perforated Styrene-Rubber (SR) Plastic Drain Pipe (discontinued 1989)	Piping, Plastic	
ASTM D 3311-94	Drain, Waste, and Vent (DWV) Plastic Fittings Patterns (Note 1)	Piping, Plastic	
ASTM D 3965-94	Rigid Acrylonitrile-Butadiene-Styrene (ABS) Compounds for Pipe and Fittings	Piping, Plastic	
ASTM D 4068-96 e1	Chlorinated Polyethylene (CPE) Sheeting for Concealed Water-Containment Membrane	Fixtures	
ASTM D 4101-96a	Propylene Plastic Injection and Extrusion Materials	Miscellaneous	
ASTM D 4551-96	Poly(Vinyl Chloride) (PVC) Plastic Flexible Concealed Water-Containment Membrane	Fixtures	
ASTM E 84-97a	Standard Test Method for Surface Burning Characteristics of Building Materials	Miscellaneous	
ASTM E 119-97	Standard Test Method for Fire Tests of Building Construction and Materials	Miscellaneous	
ASTM E 814-94b	Standard Test Method for Fire Tests of Through-Penetration Fire Stops	Miscellaneous	
ASTM F 402-93	Safe Handling of Solvent Cements, Primers, and Cleaners Used for Joining Thermoplastic Pipe and Fittings	Joints	
ASTM F 405-96	Corrugated polyethylene (PE) Tubing and Fittings	Piping, Plastic	
ASTM F 409-96a	Thermoplastic Accessible and Replaceable Plastic Tube and Tubular Fittings (Note 1)	Piping, Plastic	
ASTM F 437-96a	Threaded Chlorinated Poly(Vinyl Chloride) (CPVC) Plastic Pipe Fittings, Sch. 80	Piping, Plastic	
ASTM F 438-96a	Socket-Type Chlorinated Poly(Vinyl Chloride) (CPVC) Plastic Pipe Fittings, Sch. 40	Piping, Plastic	
ASTM F 439-96b	Socket-Type Chlorinated Poly(Vinyl Chloride) (CPVC) Plastic Pipe Fittings, Sch. 80	Piping, Plastic	
ASTM F 441-96b	Chlorinated Poly(Vinyl Chloride) (CPVC) Plastic Pipe, Sch. 40 and 80	Piping, Plastic	
ASTM F 442-96b	Chlorinated Poly(Vinyl Chloride) (CPVC) Plastic Pipe (SDR-PR)	Piping, Plastic	

Standard Number	Standard Title	Application	Indicate if Not Approved in the UPC
ASTM F 443-77 e1 [D]	Bell-End Chlorinated Poly (Vinyl Chloride) (CPVC) Pipe, Schedule 40 (discontinued 1987)	Piping, Plastic	
ASTM F 480-95	Thermoplastic Well Casing Pipe and Couplings Made in Standard Dimension Ratios (SDR) Schedule 40 and Schedule 80	Piping, Plastic	
ASTM F 493-97	Solvent Cements for Chlorinated Poly(Vinyl Chloride) (CPVC) Plastic Pipe and Fittings	Joints	
ASTM F 628-96	Acrylonitrile-Butadiene-Styrene (ABS) Sch. 40 Plastic Drain, Waste and Vent Pipe with a Foam Core (Notes 1 & 3)	Piping, Plastic	
ASTM F 656-96a	Primers for Use in Solvent Cement Joints of Poly(Vinyl Chloride) (PVC) Plastic Pipe and Fittings	Joints	
ASTM F 667-95	Large Diameter Corrugated Polyethylene Tubing and Fittings	Piping, Plastic	
ASTM F 789-95a	Type PS-46 and type PS-115 Poly(Vinyl Chloride) (PVC) Plastic Gravity Flow Sewer Pipe and Fittings (Note 1)	Piping, Plastic	
ASTM F 794-95a	Poly(Vinyl Chloride) (PVC) Profile Gravity Sewer Pipe and Fittings Based on Controlled Inside Diameter	Piping, Plastic	
ASTM F 810-93	Smoothwall Polyethylene (PE) Pipe for Use in Drainage and Waste Disposal Absorption Fields	Piping, Plastic	
ASTM F 845-95	Plastic Insert Fittings For Polybutylene (PB) Tubing	Piping, Plastic	X
ASTM F 876-97	Crosslinked Polyethylene (PEX) Tubing	Piping, Plastic	
ASTM F 877-96a	Crosslinked Polyethylene (PEX) Plastic Hot- and Cold-Water Distribution Systems	Piping, Plastic	
ASTM F 891-96	Coextruded Poly(Vinyl Chloride) (PVC) Plastic Pipe with a Cellular Core	Piping, Plastic	
ASTM F 949-96a	Poly(Vinyl Chloride) (PVC) Corrugated Sewer Pipe with a Smooth Interior and Fittings	Piping, Plastic	
ASTM F 1216-93	Rehabilitation of Existing Pipelines and Conduits by the Inversion and Curing of a Resin-Impregnated Tube	Piping, Plastic	
ASTM F 1281-98	Crosslinked Polyethylene/ Aluminum/ Crosslinked Polyethylene (PEX-Al-PEX) Pressure Pipe	Piping, Plastic	X
ASTM F 1282-98	Polyethylene/ Aluminum/ Polyethylene (PE-Al-PE) Composite Pressure Pipe	Piping, Plastic	X
ASTM F 1412-96	Polyolefin Pipe and Fittings for Corrosive Waste Drainage Systems	Piping, Plastic	
ASTM F 1673-95	Polyvinylidene Fluoride (PVDF) Corrosive Waste Drainage Systems	Piping, Plastic	
ASTM F 1743-96	Rehabilitation of Existing Pipelines and Conduits by Pulled-In-Place Installation of Cured-In-Place Thermosetting Resin Pipe (CIPP)	Piping, Plastic	
ASTM F 1807-97	Metal Insert Fittings w/ Copper Crimp Ring for SDR 9 Crosslinked Polyethylene (PEX) Tubing	Piping, Plastic	
ASTM F 1866-98	Poly (Vinyl Chloride) PVC Schedule 40 Drainage and DWV Fabricated Fittings	Piping, Plastic	
ASTM F 1960-99	Cold Expansion Fittings with PEX Reinforcing Rings for Use with Cross-linked Polyethylene (PEX) Tubing	Piping, Plastic	
ASTM F 1961-99	Metal Cold Flare Compression Fittings with Disk Springs for Cross Linked Polyethylene (PEX) Tubing	Piping, Plastic	

Standard Number	Standard Title	Application	Indicate if Not Approved in the UPC
ASTM F 1974-99	Metal Insert Fittings for Polyethylene/Aluminum/Polyethylene and Crosslinked Polyethylene/Aluminum/Crosslinked Polyethylene Composite Pressure Pipe	Piping, Plastic	
AWS A5.8-92	Filler Metals for Brazing and Braze Welding Joints AWS B2.2-91 Brazing Procedure and Performance Qualification	Certification	
AWS B2.2-91	Brazing Procedure and Performance Qualification	Certification	
AWWA C110	Ductile-Iron and Gray-Iron Fittings, 3 in. Through 48 in. (75 mm Through 1200 mm), for Water and Other Liquids (same as ANSI A21.10-93)	Piping, Ferrous	
AWWA C111	Rubber-Gasket Joints for Ductile-Iron Pressure Pipe and Fittings (same as ANSI A21.11-90)	Piping, Ferrous	
AWWA C151	Ductile-Iron Pipe, Centrifugally Cast, for Water (same as ANSI A21.51-91)	Piping, Ferrous	
AWWA C153	Ductile-Iron Compact Fittings, 3 in. Through 24 in. (76 mm Through 610 mm) and 54 in. Through 64 in. (1,400 mm Through 1,600 mm), for Water Service (same as ANSI A21.53-88)	Piping, Ferrous	
AWWA C203-91	Coal-Tar Protective Coatings and Linings for Steel Water Pipelines - Enamelled and Tape - Hot Applied Piping AWWA C213-96 Fusion-Bonded Epoxy Coating for the Interior and Exterior of Steel Water Pipelines	Piping, Ferrous	
AWWA C213-96	Fusion-Bonded Epoxy Coating for the Interior and Exterior of Steel Water Pipelines	Piping, Ferrous	
AWWA C215-94	Extruded Polyolefin Coatings for the Exterior of Steel Water Pipelines	Piping, Ferrous	
AWWA C400-93	Asbestos-Cement Distribution Pipe, 4 in. Through 16 in. (100 mm Through 400 mm) for Water Distribution Systems	Piping, Nonmetallic	
AWWA C500-93	Metal-Seated Gate Valves for Water Supply Service	Valves	
AWWA C504-88	Rubber-Seated Butterfly Valves	Valves	
AWWA C507-91	Ball Valves, 6 in. Through 48 in. (152 mm Through 1200 mm)	Valves	
AWWA C510-92	Double Check Valve Backflow-Prevention Assembly	Backflow Protection	
AWWA C511-92	Reduced-Pressure Principle Backflow-Prevention Assemblies	Backflow Protection	
AWWA C606-87	Grooved and Shouldered Joints	Joints	
AWWA C900-89	Polyvinyl Chloride (PVC) Pressure Pipe, 4 in. Through 12 in., for Water Distribution	Piping, Plastic	
AWWA C901-88	Polyethylene (PE) Pressure Pipe and Tubing, 1/2 in. (13 mm) Through 3 in. (76 mm), for Water	Piping, Plastic	
AWWA C902-88	Polybutylene (PB) Pipe, Tubing, and Fittings, 1/2 in. Through 3 in., for Water	Piping, Plastic	X
CABO A117.1-92	Specifications to Make Buildings and Facilities Accessible and Usable	Miscellaneous	
CISPI 301-97	Hubless Cast Iron Soil Pipe and Fittings for Sanitary and Storm Drain, Waste, and Vent Piping Applications (Note 1)	Piping, Ferrous	
CISPI HSN-85	Neoprene Rubber Gaskets for Hub and Spigot Cast Iron Soil Pipe and Fittings	Joints	

Standard Number	Standard Title	Application	Indicate if Not Approved in the UPC
CISPI 310-97	Couplings for Use in Connection with Hubless Cast Iron Soil Pipe and Fittings for Sanitary and Storm Drain, Waste, and Vent Piping Applications	Joints	
FS A-A-51145C FS K65.59-71	Flux, Soldering, Nonelectronic, Paste and Liquid Acrylonitrile-Butadiene-Styrene (ABS) sewer pipe and fittings	Joints Piping, Plastic	
FS M265-811	Acrylonitrile-Butadiene-Styrene (ABS) Sch. 40 plastic drain, waste and vent pipe and fittings	Piping, Plastic	
FS O-F-499D-85	Flux brazing	Joints	
FS O-F-506C-72 (D)	Flux, soldering	Joints	
FS OO-L-201 f-70	Shower pans-sheet lead, grade B, 4 lb. min.	Miscellaneous	
FS QQ-R-571C-69 [D]	Copper and nickel alloys (rods)	Miscellaneous	
FS TT-S-1732-71	Seal compound pipe joint and thread	Joints	
FS WW-P 325B-76	Lead pipe and bends	Piping	
FS WW-P-521F-77	Copper alloy (bronze) unions	Piping, Copper Alloy	
FS WW-P-541-E-Gen.1980	Plumbing fixtures, general specification	Fixtures	
FS WW-U-516A-74(b)	Copper alloy (bronze) unions	Piping, Copper Alloy	
FS WW-V-54d	Valve, Gate, Bronze (125, 150 and 200 Pound, Screwed Flange, Solder-End, for Land Use)	Valves	
FS WW-V 58b	Valves, Gate, Cast Iron; 125 and 250-Pound, Screwed and Flanged (for Land Use)	Valves	
IAPMO IS 1-91 e1	Nonmetallic Building Sewers	Piping, Nonmetallic	
IAPMO IS 2-90	Tile-Lined Roman Bathtubs	Fixtures	
IAPMO IS 3-93 e1	Copper Plumbing Tube, Pipe and Fittings	Piping, Copper Alloy	
IAPMO IS 4-96	Tile-Lined Shower Receptors (and Replacements)	Fixtures	
IAPMO IS 5-92 e1	ABS Building Drain, Waste, and Vent Pipe and Fittings	Piping, Plastic	
IAPMO IS 6-95	Hubless Cast Iron Sanitary and Rainwater Systems	Piping, Ferrous	
IAPMO IS 7-90 e1	Polyethylene (PE) cold Water Building Supply	Piping, Plastic	
IAPMO IS 8-95 e1	PVC Cold Water Building Supply and Yard Piping	Piping, Plastic	
IAPMO IS 9-95 e1	PVC Building Drain, Waste and Vent Pipe Fittings	Piping, Plastic	
IAPMO IS 11-87 e1	ABS Sewer Pipe and Fittings	Piping, Plastic	
IAPMO IS 12-93 e1	Polyethylene (PE) for Gas Yard Piping	Piping, Plastic	
IAPMO IS 13-91 e1	Protectively Coated	Pipe Piping	
IAPMO IS 15-82	Asbestos Cement Pressure Pipe for Water Service and Yard Piping	Piping, Nonmetallic	
IAPMO IS 16-84	Low Pressure Air Test for Building Sewers	Piping	
IAPMO IS 18-85 e1	Extra Strength Vitrified Clay Pipe in Building Drains	Piping, Nonmetallic	
IAPMO IS 20-98	CPVC Solvent Cemented Hot and Cold Water Distribution Systems	Piping, Plastic	
IAPMO IS 21-89 e1	Welded Copper and Copper Alloy Water Tube	Piping, Copper Alloy	
IAPMO IS 26-99	Trenchless Polyethylene (PE) Pipe for Sewer Laterals	Piping, Plastic	
IAPMO PS 1-99	Prefabricated Septic Tanks	DWV Components	
IAPMO PS 2-89	Cast Brass and Tubing P-Traps	Piping, Copper Alloy	
IAPMO PS 4-99	Drains for Prefabricated and Precast Showers	Fixtures	
IAPMO PS 7-84	Tubing Trap Wall Adapters	DWV Components	

Standard Number	Standard Title	Application	Indicate if Not Approved in the UPC
IAPMO PS 9-84	Diversion Tees and Twin Waste Elbows	DWV Components	
IAPMO PS 13-89	Testing and Rating Procedure for Grease Traps (Note 2)	DWV Components	
IAPMO PS 14-99	Flexible Metallic Water Connectors	Piping	
IAPMO PS 16-97	Subdrains for Built-Up Shower Pans	Fixtures	
IAPMO PS 23-89	Dishwasher Drain Airgaps	Backflow Protection	
IAPMO PS 25-84	Fittings for Joining Polyethylene Pipe for Water Service and Yard Piping	Joints	
IAPMO PS 31-95	Backflow Prevention Assemblies	Backflow Protection	
IAPMO PS 34-96	Polyethylene Encasement Sleeve for Potable Water Pipe and Tubing	Piping	
IAPMO PS 36-90	Lead-Free Sealing Compounds for Threaded Joints	Joints	
IAPMO PS 37-90	Black Plastic PVC or PE Pressure-Sensitive Corrosion Preventive Tape	Piping	
IAPMO PS 38-99	ABS and PVC Backwater Valves	DWV Components	
IAPMO PS 39-91	Testing Mechanical Fittings Composed of Multiple Components For Various Fitting Configuration For Use With Thermoplastic Gas Pressure Pipe	Fuel Gas	
IAPMO PS 40-91	Anodeless Transition Riser for Use with Polyethylene and PVC Gas Yard Piping	Fuel Gas	
IAPMO PS 41-99	Copper and Other Metallic Roof/Deck/Balcony Drains	DWV Components	
IAPMO PS 42-96	Pipe Alignment and Secondary Support Systems	Piping	
IAPMO PS 43-91	Cushioned Bathtubs And Whirlpool Bathtub Appliances	Fixtures	
IAPMO PS 44-92	Shielded Transition Couplings for Use with Dissimilar DWV Pipe and Fittings Above Ground	Joints	
IAPMO PS 45-91	Bathtub Three-Way Diverter Valves with Backflow Protection	Valves	
IAPMO PS 47-99	Plastic Roof Drains	DWV Components	
IAPMO PS 48-92	Material Safety Data Verification For Plumbing Products	Miscellaneous	
IAPMO PS 49-92	Backflow Prevention Requirements for Fixture Fittings with Hose Connected Singular Moveable Outlets	Backflow Protection	
IAPMO PS 50-92	Dual Flush Devices For Water Closets	Fixtures	
IAPMO PS 51-98	Plastic and Metallic Expansion Joints	Joints	
IAPMO PS 52-99	Sumps and Sewage Ejector Tanks	DWV Components	
IAPMO PS 53-92	Grooved Mechanical Pipe Couplings and Grooved End Fittings	Joints	
IAPMO PS 54-99	Metallic and Plastic Utility Boxes	Miscellaneous	
IAPMO PS 55-92	Bathwaste Strainer Drains	Fixtures	
IAPMO PS 57-92	PVC Hydraulically Actuated Diaphragm Type Water Control Valves	Valves	
IAPMO PS 58-92	Supports for Off-the-Floor Plumbing Fixtures With or Without Concealed Tanks	Fixtures	
IAPMO PS 59-92	Septic Effluent and Waste Water Diverter Valves	DWV Components	
IAPMO PS 60-96	Sewage Holding Tank Containing Sewage Ejector Pump for Direct Mounted Water Closet	DWV Components	
IAPMO PS 61-92	Fabricated Stainless Steel Security Water Closets	Fixtures	
IAPMO PS 62-93	Enameled Cast Iron Sanitary Floor Sinks	Fixtures	
IAPMO PS 63-99	Plastic Leaching Chambers	DWV Components	
IAPMO PS 64-98	Pipe Flashings	Piping	
IAPMO PS 65-93	Airgap Units for Water Conditioning Equipment Installation	Backflow Protection	

Standard Number	Standard Title	Application	Indicate if Not Approved in the UPC
IAPMO PS 66-93	Dielectric Waterway Fittings	Piping	
IAPMO PS 67-93	Early-Closure Replacement Flappers or Early-Closure Replacement Flapper With Mechanical Assemblies	Fixtures	
IAPMO PS 69-98	Plastic Bathwaste and Overflow Assemblies	Piping, Plastic	
IAPMO PS 70-93	Bathtub/Whirlpool Bathtubs with Pressure Sealed Doors	Fixtures	
IAPMO PS 71-93	Electronic Controlled Showers	Fixtures	
IAPMO PS 72-93	Valves with Atmospheric Vacuum Breakers	Valves	
IAPMO PS 73-93	Dental Vacuum Pumps	Miscellaneous	
IAPMO PS 74-99	Reinforced Flexible Water Connectors	Piping	
IAPMO PS 76-95	Ballcock or Flushometer Valve Tailpiece Trap Primers and Trap Primer Receptors/Adapters	DWV Components	
IAPMO PS 77-99	Electrohydraulic Water Closets	Fixtures	
IAPMO PS 78-95	Dual Flush for Electrohydraulic and Gravity 6 Liter (1.6 Gallons) Water Closet	Fixtures	
IAPMO PS 79-95	Multiport Electronic Trap Primer	DWV Components	
IAPMO PS 80-95	Grease Interceptors and Clarifiers	DWV Components	
IAPMO PS 81-95	Precast Concrete Seepage Pit Liners and Covers	DWV Components	
IAPMO PS 82-95	Fiberglass (Glass Fiber Reinforced Thermosetting Resin) Fittings	Piping, Plastic	
IAPMO PS 83-95	Epoxy Coated Cast Iron Sanitary Floor Sinks	Fixtures	
IAPMO PS 84-95	PVC Plastic Sanitary Floor Sinks	Fixtures	
IAPMO PS 85-95	Tools for Mechanically Formed Tee Connections in Copper Tubing	Piping	
IAPMO PS 86-95	Rainwater Diverter Valve for Nonroofed Area Slabs	DWV Components	
IAPMO PS 87-95	Diverter and Shut-Off Valves for Pool/Spas	Valves	
IAPMO PS 88-95	Pre-Pressurized Potable Water Tanks	Miscellaneous	
IAPMO PS 89-95	Soaking and Hydrotherapy (Whirlpool) Bathtubs with Hydraulic Seatlift	Fixtures	
IAPMO PS 90-95	Elastomeric Test Caps/Cleanout Caps	DWV Components	
IAPMO PS 91-95	Plastic Stabilizers for Use with Plastic Closet Bends	Piping, Plastic	
IAPMO PS 92-95	Heat Exchangers	Miscellaneous	
IAPMO PS 93-99	Water Closet Seats with Spray	Fixtures	
IAPMO PS 94-96	P-Trap, Supply Stop and Riser Insulated Protector	Miscellaneous	
IAPMO PS 95-98	Drain, Waste, and Vent Hangers and Plastic Pipe Support Hooks	Piping	
IAPMO PS 96-96	Passive Direct Solar Water Heaters	Miscellaneous	
IAPMO PS 97-97	Mechanical Cast Iron Closet Flanges	Piping, Ferrous	
IAPMO PS 98-96	Prefabricated Fiberglass Church Baptistries	Fixtures	
IAPMO PS 99-96	Terrazzo Plumbing Fixtures	Fixtures	
IAPMO PS 100-96	Porous Filter Protector for Sub-Drain Weep Holes	DWV Components	
IAPMO PS 101-97	Suction Relief Valves	Valves	
IAPMO PS 102-97	Short Pattern Fixture Trap	DWV Components	
IAPMO PS 103-97	Water Heater Stands With or Without Pans	Appliances	
IAPMO PS 104-97	Pressure Relief Connection for Dispensing Equipment	Valves	
IAPMO PS 105-97	Polyethylene Distribution Boxes	DWV Components	
IAPMO PS 106-98	Pre-Fabricated, Tileable Shower Receptors	Fixtures	
IAPMO PS 107-98	Aramid Reinforced Rubber Hose for Use in Non-potable Water Radiant Heating and Snowmelting	Piping, Plastic	X
IAPMO PS 108-98	Grease Fire Suppression Systems	Appliances	
IAPMO PS 109-96	Rigid Unshielded Mechanical Couplings for Use with Plain End Drain, Waste, and Vent (DWV) Pipe and Plain End Sewer Pipe	Joints	

Standard Number	Standard Title	Application	Indicate if Not Approved in the UPC
IAPMO PS 110-99	PVC Cold Water Compression Fittings	Fittings	
IAPMO PS 111-99	PVC Cold Water Gripper Fittings	Fittings	
IAPMO PS 112-99	PVC Plastic Valves for Cold Water Distribution Systems Outside a Building and CPVC Plastic Valves for Hot and Cold Water Distribution Systems	Valves	
IAPMO PS 113-99	Hydraulically Powered Household Food Waster Grinders	Appliances	
IAPMO PS 114-99	Remote, Floor Box Industrial Water Supply, Air Supply, Drainage	Miscellaneous	
IAPMO PS 115-99	Hot Water Demand or Automatic Activated Hot Water Pumping Systems	Miscellaneous	
IAPMO PS 116-99	Hot Water Circulating Devices Which Do Not Use a Pump	Miscellaneous	
IAPMO SPS 3-93	Skimmers (Spas, Hot Tubs and Swimming Pools)	Swimming Pools and Spas	
IAPMO SPS 4-89	Special Use Suction Fittings for Swimming Pools, Spas and Hot Tubs (For Suction Side Automatic Swimming Pool Cleaners)	Swimming Pools and Spas	
IAS LC 1-97	Fuel Gas Piping Systems Using Corrugated Stainless Steel Tubing (CSST) (same as CSA 6.26-M97)	Fuel Gas	X
MIL-F-1183 H-83 [D]	Fittings, Pipe, Cast Bronze, Silver-Brazing	Piping, Copper Alloy	
MIL-F-18180C1	Flanges and Flanged Fittings, Pipe, Steel (150, 300, 400, 600, 900, 1500, and 2500 pounds)	Piping, Ferrous	
MIL-P-17552	Pumps, Centrifugal, Water, Horizontal, General Service; and Pumps, Centrifugal Water, Horizontal, Boiler-Feed; Electric Motor or Steam Driven	Pumps	
MIL-P-21214B-92	Vertical sump pumps	Pumps	
SSPMA-85			
MIL-P-21251C	Plumping Units, Sewage, Duplex, Automatic, Wet-Pit-Type	Pumps	
MIL-P-22561-82(D)	Glass (standard cancelled per Department of Defense)	Miscellaneous	
MIL-V-29193-80(D)	Pressurized flushing devices	Fixtures	
MIL-P-52407	Pump, Centrifugal: Electric-Motor-Driven, Shallow (A)-1976 (D) Well (for Water)	Pumps	
MIL-P-62156	Submersible, axial flow, electric motor driven	Pumps	
MIL-P-B-81 (D)	(1)-1983 (D)		
SSPMA-85	Sewage pumps	Pumps	
MSS SP-25-93	Standard Marking System for Valves, Fittings, Flanges and Unions	Piping	
MSS SP-42-90 (R95)	Class 150 Corrosion Resistant Gate, Globe, Angle and Check Valves with Flanged and Butt Weld Ends	Piping, Ferrous	
MSS SP-44-91	Steel Pipeline Flanges	Piping, Ferrous	
MSS SP-58-93	Pipe Hangers And Supports – Materials, Design and Manufacture	Piping	
MSS SP-67-90	Butterfly Valves	Valves	
MSS SP-70-90	Cast Iron Gate Valves, Flanged and Threaded Ends	Valves	
MSS SP-71-90	Cast Iron Swing Check Valves, Flanged and Threaded Ends	Valves	
MSS SP-72-92	Ball Valves with Flanged or Butt-Welding Ends for General Service	Valves	

Standard Number	Standard Title	Application	Indicate if Not Approved in the UPC
MSS SP-73-91	Brazing Joints for Wrought and Cast Copper Alloy Solder Joint Pressure Fittings	Joints	
MSS SP-78-87 (R92)	Cast Iron Plug Valves, Flanged and Threaded Ends	Valves	
MSS SP-80-87	Bronze Gate, Globe, Angle and Check Valves	Valves	
MSS SP-83-87	Steel Pipe Unions Socket-Welding and Threaded	Piping, Ferrous	
MSS SP-84 [D]	Steel Valves – Socket-Welding Ends and Threaded Ends (discontinued)	Valves	
NFPA 13R-1996	Installation of Sprinkler Systems in Residential Occupancies up to and Including Four Stories in Height	Miscellaneous	
NFPA 13D-1996	Installation of Sprinkler Systems in One-and Two-Family Dwellings and Manufactured Homes	Miscellaneous	
NFPA 31-97	Installation of Oil-Burning Equipment	Miscellaneous	
NFPA 54-96	National Fuel Gas Code	Fuel Gas	
NFPA 58-98	Storage and Handling of Liquefied Petroleum Gases	Fuel Gas	
NFPA 99-99 (Ch. 2 & 4)	Medical Gas Systems	Piping	
NFPA 99-99 (Ch. 2 & 4)	Gas and Vacuum Systems	Piping	
NFPA 211-96	Chimneys, Fireplaces, Vents, and Solid Fuel-Burning Appliances	Miscellaneous	
NFPA 8501-97	Single Burner Boiler Operation	Appliances	
NSF 3-96	Commercial Spray-Type Dishwashing and Glass-washing Machines	Appliances	
NSF 12-93	Automatic Ice Making Equipment	Appliances	
NSF 14-98	Plastic Piping Components and Related Materials	Piping, Plastic	
NSF 18-96	Manual Food and Beverage Dispensing Equipment	Appliances	
NSF 24-96	Plumbing System Components for Manufactured Homes and Recreational Vehicles	Miscellaneous	
NSF 29-93	Chemical Feeders for Commercial Dishwashers	Appliances	
NSF 40-99	Residential Wastewater Treatment Systems	DWV Components	
NSF 41-98	Nonliquid Saturated Treatment Systems	DWV Components	
NSF 42-98	Drinking Water Treatment Units - Aesthetic Effects	Appliances	
NSF 44-98	Cation Exchange Water Softeners	Appliances	
NSF 46-97	Evaluation of Components and Devices Used in Wastewater Treatment Systems	DWV Components	
NSF 53-98	Drinking Water Treatment Units - Health Effects	Appliances	
NSF 58-98	Reverse Osmosis Drinking Water Treatment Systems	Appliances	
NSF 61-98	Drinking Water System Components -Health Effects	Miscellaneous	
NSF 62-97	Water Distillation Systems	Appliances	
NSPI 1-1991	Public Swimming Pools	Swimming Pools and Spas	
PDI G-101-85	Testing and Rating Procedure for Grease Interceptors with Appendix of Sizing and Installation Data	DWV Components	
PDI-WH 201-92	Water Hammer Arresters	Piping	
SAE J1670-93	Type "F" Clamps for Plumbing Applications	Joints	
SAMA LF6a	Medical Care Facility Brassware	Miscellaneous	
UL 80-96	Steel Inside Tanks for Oil-Burner Fuel	Miscellaneous	
UL 103-95	Factory-Built Chimneys for Residential Type and Building Heating Appliances	Miscellaneous	
UL 125-97	Valves for Anhydrous Ammonia and LP-Gas (Other than Safety Relief)	Valves	

Standard Number	Standard Title	Application	Indicate if Not Approved in the UPC
UL 132-97	Safety Relief Valves for Anhydrous Ammonia and LP-Gas	Valves	
UL 144-99	LP Gas Regulators	Valves	
UL 174-96	Household Electric Storage Tank Water Heaters	Appliances	
UL 343-97	Pumps for Oil-Burning Appliances	Pumps	
UL 352-97	Constant-Level Oil Valves	Valves	
UL 378-93	Draft Equipment	Miscellaneous	
UL 399-93	Drinking-Water Coolers	Appliances	
UL 430-94	Waste Disposers	Appliances	
UL 441-96	Gas Vents	Miscellaneous	
UL 443-95	Steel Auxiliary Tanks for Oil-Burner Fuel	Miscellaneous	
UL 499-97	Electrical Heating Appliances	Appliances	
UL 563-95	Ice Makers	Appliances	
UL 569-95	Pigtails and Flexible Hose Connectors for LP-Gas	Fuel Gas	
UL 723-96	Test for Surface Burning Characteristics of Building Materials	Miscellaneous	
UL 726-95	Oil-Fired Boiler Assemblies	Appliances	
UL 732-95	Oil-Fired Storage Tank Water Heaters	Appliances	
UL 749-97	Household Dishwashers	Appliances	
UL 778-96	Motor-Operated Water Pumps	Pumps	
UL 834-95	Heating, Water Supply, and Power Boilers -Electric	Appliances	
UL 921-96	Commercial Electric Dishwashers	Appliances	
UL 1453-95	Electric Booster and Commercial Storage Tank Water Heaters	Appliances	
WAC 246-290-490	Washington State Department of Health Cross Connection Control Requirements	Backflow Protection	
WQA S-100-95	Household, Commercial and Portable Exchange Water Softeners (replaced by NSF 44-98)	Appliances	
WQA S-200-93	Household and Commercial Water Filters	Appliances	
WQA S-300-91	Point-of-Use Low Pressure Reverse Osmosis Drinking Water Systems	Appliances	
3-GP-28	Fuel Oil, Canadian Government Specification Board	Miscellaneous	

Footnotes:

1. Although this standard is referenced in Table 14-1, some of the pipe, tubing, fittings, valves, or fixtures included in the standard are not acceptable for use under the provisions of the Uniform Plumbing Code.
2. PDI Standard G101 by reference.
3. Additional Requirements for Inner and Outer Layers.
4. See Section 316.1.3 for restriction.
5. Alloy C85200 for cleanout plugs.
6. Limited to domestic sewage.
7. Type II only.
8. Fixture fittings with hose connected singular moveable outlets shall have two check valves and an atmospheric vacuum breaker.
9. ASSE 1066 is not intended to limit the maximum outlet temperature at point of use.
10. See section 315.0 for Trenching, Excavation, and Backfilling requirements when installing building drains and sewers. Engineers may wish to consult ASTM D2321 when preparing plans and specifications for sewer mains or specific projects.

[Statutory Authority: RCW 19.27.031, 19.27.074, 02-01-114, § 51-56-1400, filed 12/18/01, effective 7/1/02.]

Reviser's note: The brackets and enclosed material in the text of the above section occurred in the copy filed by the agency.

WAC 51-56-201300 Appendix M—Storm drainage.

M 1.0 General.

(2003 Ed.)

M 1.1 Where Required. All roofs, paved areas, yards, courts, and courtyards shall be drained into a separate storm sewer system, or into a combined sewer system where a separate storm sewer system is not available, or to some other place of disposal satisfactory to the administrative authority. In the case of one- and two-family dwellings, storm water may be discharged on flat areas such as streets or lawns so long as the storm water shall flow away from the building and away from adjoining property, and shall not create a nuisance.

M 1.2 Storm Water Drainage to Sanitary Sewer Prohibited. Storm water shall not be drained into sewers intended for sanitary drainage only.

M 1.3 Material Uses. Rainwater piping placed within the interior of a building or run within a vent or shaft shall be of cast iron, galvanized steel, wrought iron, brass, copper, lead, Schedule 40 ABS DWV, Schedule 40 PVC DWV, or other approved materials, and changes in direction shall conform to the requirements of Section 706.0.

M 1.4 Expansion Joints Required. Expansion joints or sleeves shall be provided where warranted by temperature variations or physical conditions.

M 1.5 Subsoil Drains.

M 1.5.1 Subsoil drains shall be provided around the perimeter of buildings having basements, cellars, or crawl spaces or floors below grade. Such subsoil drains may be positioned inside or outside of the footing, shall be of perforated, or open-jointed approved drain tile or pipe not less than three (3) inches (76 mm) in diameter, and shall be laid in gravel, slag, crushed rock, approved three-quarter (3/4) inch (19.1 mm) crushed recycled glass aggregate, or other approved porous material with a minimum of four (4) inches (102 mm) surrounding the pipe on all sides. Filter media shall be provided for exterior subsoil piping.

M 1.5.2 Subsoil drains shall be piped to a storm drain, to an approved water course, to the front street curb or gutter, or to an alley; or the discharge from the subsoil drains shall be conveyed to the alley by a concrete gutter. Where a continuously flowing spring or groundwater is encountered, subsoil drains shall be piped to a storm drain or an approved water course.

M 1.5.3 Where it is not possible to convey the drainage by gravity, subsoil drains shall discharge to an accessible sump pit provided with an approved automatic electric pump. A sump pit shall be at least fifteen (15) inches (381 mm) in diameter, eighteen (18) inches (457 mm) in depth, and provided with a fitted cover. The sump pump shall have an adequate capacity to discharge all water coming into the sump as it accumulates to the required discharge point, and the capacity of the pump shall not be less than fifteen (15) gpm (1.0 L/s). The discharge piping from the sump pump shall be a minimum of one and one-half (1-1/2) inches (38 mm) in diameter and have a union to make the pump accessible for servicing.

M 1.5.4 For separate dwellings not serving continuously flowing springs or ground water, the sump discharge pipe may discharge onto a concrete splash block with a minimum length of twenty-four (24) inches (610 mm). This pipe shall be within four (4) inches (102 mm) of the splash block and positioned to direct the flow parallel to the recessed line of the splash block.

M 1.5.5 Subsoil drains subject to backflow when discharging into a storm drain shall be provided with a backwater valve in the drain line so located as to be accessible for inspection and maintenance.

M 1.5.6 Nothing in Section 1501.5 shall prevent drains that serve either subsoil drains or areaways of a detached building from discharging to a properly graded open area, provided that:

- (1) They do not serve continuously flowing springs or ground water;
- (2) The point of discharge is at least ten (10) feet (3048 mm) from any property line; and
- (3) It is impracticable to discharge such drains to a storm drain, to an approved water course, to the front street curb or gutter, or to an alley.

M 1.6 Building Subdrains. Building subdrains located below the public sewer level shall discharge into a sump or receiving tank, the contents of which shall be automatically lifted and discharged into the drainage system as required for building sumps.

M 1.7 Areaway Drains. All open subsurface space adjacent to a building, serving as an entrance to the basement or cellar of a building, shall be provided with a drain or drains. Such areaway drains shall be two (2) inches (51 mm) minimum diameter for areaways not exceeding one hundred (100) square feet (9.3 m²) in area, and shall be discharged in the manner provided for subsoil drains not serving continuously flowing springs or ground water (see Section 1501.5.2). Areaways in excess of one hundred (100) square feet (9.3 m²) shall not drain into subsoil. Areaway drains for areaways exceeding one hundred (100) square feet (9.3 m²) shall be sized according to Table M-2.

M 1.8 Window Areaway Drains. Window areaways not exceeding ten (10) square feet (0.9 m²) in area may discharge to the subsoil drains through a two (2) inch (51 mm) pipe. However, window areaways exceeding ten (10) square feet (0.9 m²) in area shall be handled in the manner provided for entrance areaways (see Section 1501.7).

M 1.9 Filling Stations and Motor Vehicle Washing Establishments. Public filling stations and motor vehicle washing establishments shall have the paved area sloped toward sumps or gratings within the property lines. Curbs not less than six (6) inches (152 mm) high shall be placed where required to direct water to gratings or sumps.

M 1.10 Paved Areas. Where the occupant creates surface water drainage, the sumps, gratings or floor drains shall be piped to a storm drain or an approved water course.

M 1.11 Roof Drainage.

M 1.11.1 Primary Roof Drainage. Roof areas of a building shall be drained by roof drains or gutters. The location and sizing of drains and gutters shall be coordinated with the structural design and pitch of the roof. Unless otherwise required by the administrative authority, roof drains, gutters, vertical conductors or leaders, and horizontal storm drains for primary drainage shall be sized based on a storm of sixty (60) minutes duration and 100-year return period (see Appendix D).

M 1.11.2 Secondary Roof Drainage.

M 1.11.2.1 Where parapet walls or other construction extend above the roof and create areas where storm water would become trapped if the primary roof drainage system failed to provide sufficient drainage, an independent secondary roof drainage system consisting of scuppers, standpipes, or roof drains shall be provided. Secondary roof drainage systems shall be sized in accordance with Section 1501.11.1 of this code. Overflow drains shall be the same size as the roof drains with the inlet flow line two (2) inches (51 mm) above the low point of the roof and shall be installed independent from the roof drains.

M 1.11.2.2 Where secondary roof drainage is provided by means of roof drains or standpipes, the secondary system shall be separate from the primary system and shall discharge independently at grade or other approved point of discharge.

M 1.11.2.3 Where secondary roof drainage is provided, the overflow level(s) into the secondary system shall be determined by the structural design of the roof, including roof deflection, at a level not less than two (2) inches (51 mm) above the level of the primary drain. An allowance shall be made to account for the required overflow head of water above the secondary inlets. The elevation of the secondary inlet plus the required overflow head shall not exceed the maximum allowable water level on the roof.

M 1.11.2.4 Scuppers shall be sized as rectangular weirs, using hydraulic principles to determine the required length and resulting overflow head (see Appendix D). Secondary roof drains and standpipes shall be sized according to Table M-1. Where standpipes are used, the head allowance required under Section 1501.11.2.3 shall be not less than one and one-half (1-1/2) inches (38 mm).

M 1.11.3 Equivalent Systems. When approved by the administrative authority, the requirements of Sections 1501.11.1 and 1501.11.2 shall not preclude the installation of an engineered roof drainage system that has sufficient capacity to prevent water from ponding on the roof in excess of that allowed in the roof structural design with a rainfall rate of at least twice that for a 100-year, 60-minute storm and with a blockage in any single point in the storm drainage system.

M 1.12 Cleanouts.

M 1.12.1 Cleanouts for building storm drains shall comply with the requirements of this section. Rain leaders and conductors connected to a building storm sewer shall have a cleanout installed at the base of the outside leader or outside conductor before it connects to the horizontal drain. Cleanouts shall be placed inside the building near the connection between the building drain and the building sewer or installed outside the building at the lower end of the building drain and extended to grade.

M 1.12.2 Each cleanout shall be installed so that it opens to allow cleaning in the direction of flow of the soil or waste or at right angles thereto, and except in the case of wye branch and end-of-line cleanouts, shall be installed vertically above the flow line of the pipe.

M 1.12.3 Cleanouts installed under concrete or asphalt paving shall be made accessible by yard boxes, or extending flush with paving with approved materials and be adequately protected.

M 1.12.4 Approved manholes may be installed in lieu of cleanouts when first approved by the administrative authority. The maximum distance between manholes shall not exceed three hundred (300) feet (91.4 m).

The inlet and outlet connections shall be made by the use of a flexible compression joint no closer than twelve (12) inches (305 mm) to, and not farther than three (3) feet (914

(2003 Ed.)

mm) from the manhole. No flexible compression joints shall be embedded in the manhole base.

M 1.13 All rainwater sumps serving "public use" occupancy buildings shall be provided with dual pumps arranged to function alternately in case of overload of mechanical failure.

M 2.0 Materials.

M 2.1 Conductors.

M 2.1.1 Conductors installed aboveground in buildings shall be constructed of materials specified in Table 14-1.

M 2.1.2 The inside of conductors installed above ground level shall be of seamless copper water tube, Type K, L or M; Schedule 40 copper pipe or Schedule 40 copper alloy pipe; Type DWV copper drainage tube; service weight cast iron soil pipe or hubless cast iron soil pipe; standard weight galvanized steel pipe; or Schedule 40 ABS or Schedule 40 PVC plastic pipe.

M 2.2 Leaders.

M 2.2.1 Leaders shall be constructed of materials specified in Table 14-1.

M 2.2.2 Leaders shall be of seamless copper water tube, Type K, L or M; Schedule 40 copper pipe; Schedule 40 copper alloy pipe; type DWV copper drainage tube; service weight cast iron soil pipe or hubless cast iron soil pipe; galvanized steel sheet metal or copper sheet metal; standard weight galvanized steel pipe; Class DL or XL lead pipe; or Schedule 40 ABS or Schedule 40 PVC plastic pipe.

M 2.3 Underground Building Storm Drains. All underground building storm drains shall be constructed of materials specified in Table 14-1.

M 2.4 Building Storm Sewers. Building storm sewers shall be constructed of materials specified in Table 14-1.

M 2.5 Subsoil Drains.

M 2.5.1 Subsoil drains shall be constructed of materials specified in Table 14-1.

M 2.5.2 Subsoil drains shall be open-jointed or of perforated pipe, vitrified clay, plastic, cast iron, or porous concrete.

M 3.0 Traps on Storm Drains and Leaders.

M 3.1 Where Required. Leaders and storm drains, when connected to a combined sewer, shall be trapped. Floor and area drains connected to a storm drain shall be trapped.

EXCEPTION: Traps shall not be required where roof drains, rain leaders and other inlets are at locations allowed under Section 906.0, Vent Terminals.

M 3.2 Where Not Required. No trap shall be required for a leader(s) or conductor(s) which is connected to a sewer carrying storm water exclusively.

M 3.3 Trap Size. Traps, when installed for individual conductors, shall be the same size as the horizontal drain to which they are connected.

M 3.4 Method of Installation of Combined Sewer. Individual storm-water traps shall be installed on the storm-water drain branch serving each storm-water inlet, or a single trap shall be installed in the main storm drain just before its connection with the combined building sewer. Such traps shall be provided with an accessible cleanout on the outlet side of the trap.

M 4.0 Leaders, Conductors, and Connections.

M 4.1 Improper Use. Leaders or conductors shall not be used as soil, waste, or vent pipes, nor shall soil, waste, or vent pipes be used as leaders or conductors.

M 4.2 Protection of Leaders. Leaders installed along alleyways, driveways, or other locations where they may be exposed to damage shall be protected by metal guards, recessed into the wall, or constructed from ferrous pipe.

M 4.3 Combining Storm with Sanitary Drainage. The sanitary and storm drainage system of a building shall be entirely separate, except where a combined sewer is used, in which case the building storm drain shall be connected in the same horizontal plane through single wye fittings to the combined building sewer at least ten (10) feet (3048 mm) downstream from any soil stack.

M 5.0 Roof Drains.

M 5.1 Material.

M 5.1.1 Roof drains shall be constructed of materials specified in Table 14-1.

M 5.1.2 Roof drains shall be of cast iron, copper or copper alloy, lead or plastic.

M 5.2 Dome or Strainer for General Use. All roof drains and overflow drains, except those draining to hanging gutters, shall be equipped with strainers extending not less than four (4) inches (102 mm) above the surface of the roof immediately adjacent to the drain. Strainers shall have a minimum inlet area above the roof level of not less than one and one-half (1-1/2) times the area of the conductor or leader to which the drain is connected.

M 5.3 Strainers for Flat Decks. Roof drain strainers for use on sun decks, parking decks, and similar areas which are normally serviced and maintained may be of the flat surface-type. Such roof drain strainers shall be level with the deck and shall have an available inlet area of no less than two (2) times the area of the conductor or leader to which the drain is connected.

M 5.4 Roof Drain Flashings. Connection between the roof and roof drains which pass through the roof and into the interior of the building shall be made watertight by the use of proper flashing material.

M 5.4.1 Where lead flashing material is used, it shall be a minimum of four (4) pounds per square foot (19.5 kg/m²).

M 5.4.2 Where copper flashing material is used, it shall be a minimum of twelve (12) ounces per square foot (3.7 kg/m²).

M 6.0 Size of Leaders, Conductors, and Storm Drains.

M 6.1 Vertical Conductors and Leaders. Vertical conductors and leaders shall be sized on the basis of the maximum projected roof area and Table M-1.

M 6.2 Size of Horizontal Storm Drains and Sewers. The size of building storm drains or building storm sewers or any of their horizontal branches shall be based upon the maximum projected roof or paved area to be handled and Table M-2.

M 6.3 Size of Roof Gutters. The size of semicircular gutters shall be based on the maximum projected roof area and Table M-3.

M 6.4 Side Walls Draining onto a Roof. Where vertical walls project above a roof so as to permit storm water to drain to the roof area below the adjacent roof area may be computed from Table M-1 as follows:

1. For one (1) wall – add fifty (50) percent of the wall area to the roof area figures.
2. For two (2) adjacent walls – add thirty-five (35) percent of the total wall areas.
3. Two (2) walls opposite of same height – add no additional area.
4. Two (2) walls opposite of differing heights – add fifty (50) percent of wall area above top of lower wall.
5. Walls on three (3) sides – add fifty (50) percent of area of the inner wall below the top of the lowest wall, plus allowance for the area of wall above top of lowest wall, per (2) and (4) above.
6. Walls on four (4) sides – no allowance for wall areas below top of lowest wall – add for areas above the top of the lowest wall per (1), (2), (4) and (5) above.

M 7.0 Values for Continuous Flow.

Where there is a continuous or semi-continuous discharge into the building storm drain or building storm sewer, as from a pump, ejector, air-conditioning plant, or similar device, one (1) gpm (3.8 L/min.) of such discharge shall be computed as being equivalent to twenty-four (24) square feet (2.2 m²) of roof area, based upon a rate of rainfall of four (4) inches (102 mm) per hour.

M 8.0 Testing.

M 8.1 Testing Required. New building storm drainage systems and parts of existing systems that have been altered, extended or repaired shall be tested as described in Section 1508.2.1 to disclose leaks and defects.

M 8.2 Methods of Testing Storm Drainage Systems.

Except for outside leaders and perforated or open jointed drain tile, the piping of storm drain systems shall be tested upon completion of the rough piping installation by water or air, and proved tight. The administrative authority may require the removal of any cleanout plugs to ascertain if the pressure has reached all parts of the system. Either of the following test methods shall be used:

M 8.2.1 Water Test. After piping has been installed, the water test shall be applied to the drainage system, either in its

entirety or in sections. If applied to the entire system, all openings in the piping shall be tightly closed except for the highest opening, and the system shall be filled with water to the point of overflow. If the system is tested in sections, each opening shall be tightly plugged except for the highest opening of the section under test, and each section shall be filled with water, but no section shall be tested with less than a ten (10) foot (3048 mm) head of water. In testing successive sections, at least the upper ten (10) foot (3048 mm) of the next preceding section shall be tested so that no joint of pipe in the building (except the uppermost ten (10) foot (3048 mm) of a roof drainage system, which shall be filled with water to the flood level of the uppermost roof drain) shall have been submitted to a test of less than a ten (10) foot (3048 mm) head of water. The water shall be kept in the system or in the portion under test for at least fifteen (15) minutes before inspection starts; the system shall then be tight at all points.

M 8.2.2 Air Test. The air test shall be made by attaching an air compressor testing apparatus to any suitable opening after closing all other inlets and outlets to the system, forcing air into the system until there is a uniform gage pressure of five (5) psi (34.5 kPa) or sufficient to balance a column of mercury ten (10) inches (254 mm) in height. This pressure shall be held without introduction of additional air for a period of at least fifteen (15) minutes.

M 8.2.3 Exceptions. When circumstances exist that make air and water tests, described in Sections 1508.2.1 and 1508.2.2 above, impractical, and for minor maintenance, repairs and installations, the administrative authority may perform the inspection as considered advisable by said authority to assure that the work has been in accordance with provisions of this code.

TABLE M-1
Sizing Roof Drains, Leaders, and Vertical Rainwater Piping

Size of Drain, Leader or Pipe, Inches	Flow, gpm	Maximum Allowable Horizontal Projected Roof Areas Square feet at Various Rainfall Rates					
		1"/Hr	2"/Hr	3"/Hr	4"/Hr	5"/Hr	6"/Hr
2	23	2176	1088	725	544	435	363
3	67	6440	3220	2147	1610	1288	1073
4	144	13,840	6920	4613	3460	2768	2307
5	261	25,120	12,560	8373	6280	5024	4187
6	424	40,800	20,400	13,600	10,200	8160	6800
8	913	88,000	44,000	29,333	22,000	17,600	14,667

TABLE M-1 (Metric)
Sizing Roof Drains, Leaders, and Vertical Rainwater Piping

Size of Drain, Leader or Pipe, mm	Flow, L/s	Maximum Allowable Horizontal Projected Roof Areas Square meters at Various Rainfall Rates					
		25mm/Hr	50mm/Hr	75mm/Hr	100mm/Hr	125mm/Hr	150mm/Hr
50	1.5	202	101	67	51	40	34
75	4.2	600	300	200	150	120	100
100	9.1	1286	643	429	321	257	214
125	16.5	2334	1117	778	583	467	389
150	26.8	3790	1895	1263	948	758	632
200	57.6	8175	4088	2725	2044	1635	1363

- Notes:
1. The sizing data for vertical conductors, leaders, and drains is based on the pipes flowing 7/24 full.
 2. For rainfall rates other than those listed, determine the allowable roof area by dividing the area given in the 1 inch/hour (25 mm/hr) column by the desired rainfall rate.
 3. Vertical piping may be round, square, or rectangular. Square pipe shall be sized to enclose its equivalent round pipe. Rectangular pipe shall have at least the same cross-sectional area as its equivalent round pipe, except that the ratio of its side dimensions shall not exceed 3 to 1.

TABLE M-2
Sizing of Horizontal Rainwater Piping

Size of Pipe, inches	Flow at 1/8"/ft slope, gpm	Maximum Allowable Horizontal Projected Roof Areas Square Feet at Various Rainfall Rates					
		1"/Hr	2"/Hr	3"/Hr	4"/Hr	5"/Hr	6"/Hr
3	34	3288	1644	1096	822	657	548
4	78	7520	3760	2506	1880	1504	1253
5	139	13,360	6680	4453	3340	2672	2227
6	222	21,400	10,700	7133	5350	4280	3566
8	478	46,000	23,000	15,330	11,500	9200	7670
10	860	82,800	41,400	27,600	20,700	16,580	13,800

Size of Pipe, inches	Flow at 1/8"/ft slope, gpm	Maximum Allowable Horizontal Projected Roof Areas Square Feet at Various Rainfall Rates					
		1"/Hr	2"/Hr	3"/Hr	4"/Hr	5"/Hr	6"/Hr
12	1384	133,200	66,600	44,400	33,300	26,650	22,200
15	2473	238,000	119,000	79,333	59,500	47,600	39,650

Size of Pipe, inches	Flow at 1/4"/ft slope, gpm	Maximum Allowable Horizontal Projected Roof Areas Square Feet at Various Rainfall Rates					
		1"/Hr	2"/Hr	3"/Hr	4"/Hr	5"/Hr	6"/Hr
3	48	4640	2320	1546	1160	928	773
4	110	10,600	5300	3533	2650	2120	1766
5	196	18,880	9440	6293	4720	3776	3146
6	314	30,200	15,100	10,066	7550	6040	5033
8	677	65,200	32,600	21,733	16,300	13,040	10,866
10	1214	116,800	58,400	38,950	29,200	23,350	19,450
12	1953	188,000	94,000	62,600	47,000	37,600	31,350
15	3491	336,000	168,000	112,000	84,000	67,250	56,000

Size of Pipe, inches	Flow at 1/2"/ft slope, gpm	Maximum Allowable Horizontal Projected Roof Areas Square Feet at Various Rainfall Rates					
		1"/Hr	2"/Hr	3"/Hr	4"/Hr	5"/Hr	6"/Hr
3	68	6576	3288	2192	1644	1310	1096
4	156	15,040	7520	5010	3760	3010	2500
5	278	26,720	13,360	8900	6680	5320	4450
6	445	42,800	21,400	14,267	10,700	8580	7140
8	956	92,000	46,000	30,650	23,000	18,400	15,320
10	1721	165,600	82,800	55,200	41,400	33,150	27,600
12	2768	266,400	133,200	88,800	66,600	53,200	44,400
15	4946	476,000	238,000	158,700	119,000	95,200	79,300

- Notes: 1. The sizing data for horizontal piping is based on the pipes flowing full.
 2. For rainfall rates other than those listed, determine the allowable roof area by dividing the area given in the 1 inch/hr (25mm/hr) column by the desired rainfall rate.

TABLE M-2 (Metric)
Sizing of Horizontal Rainwater Piping

Size of Pipe, mm	Flow at 10mm/m slope, L/s	Maximum Allowable Horizontal Projected Roof Areas Square Meters at Various Rainfall Rates					
		25mm/Hr	50mm/Hr	75mm/Hr	100mm/Hr	125mm/Hr	150mm/Hr
75	2.1	305	153	102	76	61	51
100	4.9	700	350	233	175	140	116
125	8.8	1241	621	414	310	248	207
150	14.0	1988	994	663	497	398	331
200	30.2	4273	2137	1424	1068	855	713
250	54.3	7692	3846	2564	1923	1540	1282
300	87.3	12,375	6187	4125	3094	2476	2062
375	156.0	22,110	11,055	7370	5528	4422	3683

Size of Pipe, mm	Flow at 20mm/m slope, L/s	Maximum Allowable Horizontal Projected Roof Areas Square Meters at Various Rainfall Rates					
		25mm/Hr	50mm/Hr	75mm/Hr	100mm/Hr	125mm/Hr	150 mm/Hr
75	3.0	431	216	144	108	86	72
100	6.9	985	492	328	246	197	164
125	12.4	1754	877	585	438	351	292
150	19.8	2806	1403	935	701	561	468
200	42.7	6057	3029	2019	1514	1211	1009
250	76.6	10,851	5425	3618	2713	2169	1807
300	123.2	17,465	8733	5816	4366	3493	2912
375	220.2	31,214	15,607	10,405	7804	6248	5202

Size of Pipe, mm	Flow at 40mm/m slope, L/s	Maximum Allowable Horizontal Projected Roof Areas Square Meters at Various Rainfall Rates					
		25mm/Hr	50mm/Hr	75mm/Hr	100mm/Hr	125mm/Hr	150mm/Hr
75	4.3	611	305	204	153	122	102
100	9.8	1400	700	465	350	280	232
125	17.5	2482	1241	827	621	494	413
150	28.1	3976	1988	1325	994	797	663
200	60.3	8547	4273	2847	2137	1709	1423
250	108.6	15,390	7695	5128	3846	3080	2564
300	174.6	24,749	12,374	8250	6187	4942	4125
375	312.0	44,220	22,110	14,753	11,055	8853	7367

Notes: 1. The sizing data for horizontal piping is based on the pipes flowing full.
 2. For rainfall rates other than those listed, determine the allowable roof area by dividing the area given in the 1 inch/hr (25mm/hr) column by the desired rainfall rate.

**TABLE M-3
Size of Gutters**

Diameter of Gutter in Inches	Maximum Rainfall in Inches per Hour				
	2	3	4	5	6
1/16" per ft slope					
3	340	226	170	136	113
4	720	480	360	288	240
5	1250	834	625	500	416
6	1920	1280	960	768	640
7	2760	1840	1380	1100	918
8	3980	2655	1990	1590	1325
10	7200	4800	3600	2880	2400

Diameter of Gutter in Inches	Maximum Rainfall in Inches per Hour				
	2	3	4	5	6
1/8" per ft slope					
3	480	320	240	192	160
4	1020	681	510	408	340
5	1760	1172	880	704	587
6	2720	1815	1360	1085	905
7	3900	2600	1950	1560	1300
8	5600	3740	2800	2240	1870
10	10200	6800	5100	4080	3400

Diameter of Gutter in Inches	Maximum Rainfall in Inches per Hour				
	2	3	4	5	6
1/4" per ft slope					
3	680	454	340	272	226
4	1440	960	720	576	480
5	2500	1668	1250	1000	834
6	3840	2560	1920	1536	1280
7	5520	3680	2760	2205	1840
8	7960	5310	3980	3180	2655
10	14,400	9600	7200	5750	4800

Diameter of Gutter in Inches	Maximum Rainfall in Inches per Hour				
	2	3	4	5	6
1/2" per ft slope					
3	960	640	480	384	320
4	2040	1360	1020	816	680
5	3540	2360	1770	1415	1180
6	5540	3695	2770	2220	1850
7	7800	5200	3900	3120	2600
8	11,200	7460	5600	4480	3730
10	20,000	13,300	10,000	8000	6660

**TABLE M-3 (Metric)
Size of Gutters**

Diameter of Gutter in mm	Maximum Rainfall in Millimeters per Hour				
	50.8	76.2	101.6	127.0	152.4
5.2mm/m slope					
76.2	31.6	21.0	15.8	12.6	10.5
101.6	66.9	44.6	33.4	26.8	22.3
127.0	116.1	77.5	58.1	46.5	38.7
152.4	178.4	119.1	89.2	71.4	59.5
177.8	256.4	170.9	128.2	102.2	85.3
203.2	369.7	246.7	184.9	147.7	123.1
254.0	668.9	445.9	334.4	267.6	223.0

Diameter of Gutter in mm	Maximum Rainfall in Millimeters per Hour				
	50.8	76.2	101.6	127.0	152.4
10.4mm/m slope					
76.2	44.6	29.7	22.3	17.8	14.9
101.6	94.8	63.3	47.4	37.9	31.6
127.0	163.5	108.9	81.8	65.4	54.5
152.4	252.7	168.6	126.3	100.8	84.1
177.8	362.3	241.5	181.2	144.9	120.8
203.2	520.2	347.5	260.1	208.1	173.7
254.0	947.6	631.7	473.8	379.0	315.9

Diameter of Gutter in mm	Maximum Rainfall in Millimeters per Hour				
	50.8	76.2	101.6	127.0	152.4
20.9mm/m slope					
76.2	63.2	42.2	31.6	25.3	21.0
101.6	133.8	89.2	66.9	53.5	44.6
127.0	232.3	155.0	116.1	92.9	77.5
152.4	356.7	237.8	178.4	142.7	118.9
177.8	512.8	341.9	256.4	204.9	170.9
203.2	739.5	493.3	369.7	295.4	246.7
254.0	1338.0	891.8	668.9	534.2	445.9

Diameter of Gutter in mm	Maximum Rainfall in Millimeters per Hour				
	50.8	76.2	101.6	127.0	152.4
41.7mm/m slope					
76.2	89.2	59.5	44.6	35.7	29.7
101.6	189.5	126.3	94.8	75.8	63.2
127.0	328.9	219.2	164.4	131.5	109.6
152.4	514.7	343.3	257.3	206.2	171.9
177.8	724.6	483.1	362.3	289.9	241.4
203.2	1040.5	693.0	520.2	416.2	346.5
254.0	1858.0	1238.4	929.0	743.2	618.7

[Statutory Authority: RCW 19.27.031, 19.27.074. 02-01-114, § 51-56-201300, filed 12/18/01, effective 7/1/02.]

**Chapter 51-57 WAC
STATE BUILDING CODE ADOPTION AND
AMENDMENT OF APPENDIX A AND APPENDIX I
OF THE 2000 EDITION OF THE UNIFORM
PLUMBING CODE**

WAC 51-57-001 Authority. These rules are adopted under the authority of chapter 19.27 RCW.

[Statutory Authority: RCW 19.27.031, 19.27.074. 02-01-114, § 51-57-001, filed 12/18/01, effective 7/1/02.]

WAC

- 51-57-001 Authority.
- 51-57-002 Purpose.
- 51-57-003 Uniform Plumbing Code standards.
- 51-57-007 Exceptions.
- 51-57-008 Implementation.
- 51-57-790000 Installation Standard 7-90—Polyethylene cold water building supply and yard piping.
- 51-57-895000 Installation Standard 8-95—PVC cold water building supply and yard piping.

WAC 51-57-002 Purpose. The purpose of these rules is to implement the provisions of chapter 19.27 RCW, which provides that the state building code council shall maintain the State Building Code in a status which is consistent with the purpose as set forth in RCW 19.27.020. In maintaining the codes, the council shall regularly review updated versions of the codes adopted under the act, and other pertinent infor-

mation, and shall amend the codes as deemed appropriate by the council.

[Statutory Authority: RCW 19.27.031, 19.27.074. 02-01-114, § 51-57-002, filed 12/18/01, effective 7/1/02.]

WAC 51-57-003 Uniform Plumbing Code Standards.

The 2000 edition of the Uniform Plumbing Code Standards (Appendixes A and I), published by the International Association of Plumbing and Mechanical Officials are hereby adopted by reference.

[Statutory Authority: RCW 19.27.031, 19.27.074. 02-01-114, § 51-57-003, filed 12/18/01, effective 7/1/02.]

WAC 51-57-007 Exceptions. The exceptions and amendments to the Uniform Codes contained in the provisions of chapter 19.27 RCW shall apply in cases of conflict with any of the provisions of these rules.

[Statutory Authority: RCW 19.27.031, 19.27.074. 02-01-114, § 51-57-007, filed 12/18/01, effective 7/1/02.]

WAC 51-57-008 Implementation. The Uniform Plumbing Code Standards adopted by chapter 19.27 RCW shall become effective in all counties and cities of this state on July 1, 2002, unless local government residential amendments have been approved by the state building code council.

[Statutory Authority: RCW 19.27.031, 19.27.074. 02-01-114, § 51-57-008, filed 12/18/01, effective 7/1/02.]

**WAC 51-57-790000 Installation Standard 7-90—
Polyethylene cold water building supply and yard piping.**

604.1 Location. Polyethylene piping may terminate within a building or structure. The connection to the potable water distribution system shall be accessible, except that it may be buried underground outside of the building or structure in an accessible location. Barbed insert fittings with hose clamps are prohibited within a building.

[Statutory Authority: RCW 19.27.031, 19.27.074. 02-01-114, § 51-57-790000, filed 12/18/01, effective 7/1/02.]

**WAC 51-57-895000 Installation Standard 8-95—
PVC cold water building supply and yard piping.**

604.1 Location. PVC piping may terminate within a building or structure. The connection to the potable water distribution system shall be accessible, except that it may be buried underground outside of the building or structure in an accessible location.

[Statutory Authority: RCW 19.27.031, 19.27.074. 02-01-114, § 51-57-895000, filed 12/18/01, effective 7/1/02.]