

WSR 07-24-034
PROPOSED RULES
DEPARTMENT OF
SOCIAL AND HEALTH SERVICES
(Economic Services Administration)
[Filed November 30, 2007, 7:55 a.m.]

Original Notice.

Preproposal statement of inquiry was filed as WSR 06-21-055.

Title of Rule and Other Identifying Information: The department is amending WAC 388-310-0400 WorkFirst—Entering the WorkFirst program as a mandatory participant, 388-310-0500 WorkFirst—Individual responsibility plan, 388-310-0600 WorkFirst—Job search, 388-310-0900 WorkFirst—Basic education, 388-310-1000 WorkFirst—Vocational education, 388-310-1050 WorkFirst—Job skills enhancement, 388-310-1100 WorkFirst—Work experience, 388-310-1400 WorkFirst—Community service, 388-310-1500 WorkFirst—Employment conditions, and 388-310-1700 WorkFirst—Self-employment.

Hearing Location(s): Office Building 2 - Auditorium, DSHS Headquarters, 1115 Washington, Olympia, WA 98504 (public parking at 11th and Jefferson. A map is available at <http://www1.dshs.wa.gov/msa/rpau/RPAU-OB-2directions.html> or by calling (360) 664-6094), on January 22, 2008, at 10:00 a.m.

Date of Intended Adoption: Not earlier than January 23, 2008.

Submit Written Comments to: DSHS Rules Coordinator, P.O. Box 45850, Olympia, WA 98504, delivery 4500 10th Avenue S.E., Lacey, WA 98503, e-mail DSHSRULES.COORDINATOR@dshs.wa.gov, fax (360) 664-6185, by 5 p.m. on January 22, 2008.

Assistance for Persons with Disabilities: Contact Jenisha Johnson, DSHS rules consultant, by January 15, 2007 [2008], TTY (360) 664-6178 or (360) 664-6094 or by e-mail at johnsjl4@dshs.wa.gov.

Purpose of the Proposal and Its Anticipated Effects, Including Any Changes in Existing Rules: The department is amending these rules to comply with federal law changes under the Deficit Reduction Act of 2005 (DRA), Public Law 109-171.

Reasons Supporting Proposal: The changes are necessary to comply with the state of Washington's TANF verification plan approved by Health and Human Services on September 14, 2007.

Statutory Authority for Adoption: RCW 74.04.050, 74.04.055, 74.04.057, and 74.08.090.

Statute Being Implemented: RCW 74.04.050, 74.04.055, 74.04.057, and 74.08.0900 [74.08.090].

Rule is necessary because of federal law, Deficit Reduction Act of 2005 (DRA), Public Law 109-171.

Name of Proponent: Department of social and health services, governmental.

Name of Agency Personnel Responsible for Drafting, Implementation and Enforcement: Aurea Figueroa, 1009 Colledge S.E., Lacey, WA 98504, (360) 725-4623.

No small business economic impact statement has been prepared under chapter 19.85 RCW. These proposed rules do not have an economic impact on small businesses. The pro-

posed amendments only affect DSHS clients by defining what are WorkFirst activities and how they are verified.

A cost-benefit analysis is not required under RCW 34.05.328. These amendments are exempt as allowed under RCW 34.05.328 (5)(b)(vii) which states in-part, "[t]his section does not apply to...rules of the department of social and health services relating only to client medical or financial eligibility and rules concerning liability for care of dependents." These rules affect only client's activities in WorkFirst and how the activity is verified.

November 21, 2007
Stephanie E. Schiller
Rules Coordinator

AMENDATORY SECTION (Amending WSR 06-08-044, filed 3/30/06, effective 6/1/06)

WAC 388-310-0400 WorkFirst—Entering the WorkFirst program as a mandatory participant. (1) What happens when I enter the WorkFirst program as a mandatory participant?

If you are a mandatory participant, you must follow instructions as written in your individual responsibility plan (see WAC 388-310-0500), which is written after you have participated in a comprehensive evaluation of elements related to your employability. If you have been identified as someone who needs necessary supplemental accommodation (NSA) services (defined in chapter 388-472 WAC) your case manager will first develop an accommodation plan to help you access WorkFirst services. The case manager will use the accommodation plan to help develop your IRP with you. If you have been identified as a victim of family violence (defined in WAC 388-61-001), you and your case manager will develop an IRP to help you with your situation, including referrals to appropriate services.

If you are a mandatory participant, your case manager will refer you to WorkFirst activities unless any of the following applies to you:

(a) You work thirty-two or more hours a week. **"Work"** means to engage in any legal, income generating activity which is taxable under the United States tax code or which would be taxable with or without a treaty between an Indian Nation and the United States;

(b) You work sixteen or more hours a week in the federal or state work study program and you attend a Washington state community or technical college at least half time;

(c) You work twenty or more hours a week in unsubsidized employment and attend a Washington state community or technical college at least half time;

(d) You are under the age of eighteen, have not completed high school, GED or its equivalent and are in school full time;

(e) You are eighteen or nineteen years of age and are attending high school or an equivalent full time;

(f) You are pregnant or have a child under the age of twelve months, and are participating in other pregnancy to employment activities. See WAC 388-310-1450;

(g) Your situation prevents you from looking for a job and you are conducting activities identified on your IRP to help you with your situation. (For example, you may be

unable to look for a job while you have health problems or you are homeless); or

(h) Your situation prevents you from looking for work because you are a victim of family violence and you are conducting activities on your IRP to help you with your situation.

(2) How will I know what my participation requirements are?

(a) Your individual responsibility plan will describe what you need to do to be able to enter job search or other WorkFirst activities and then find a job (see WAC 388-310-0500 and 388-310-0700).

(b) If you enter the pregnancy to employment pathway (described in WAC ((388-310-1450(2))) 388-310-1450(3)), you must take part in an assessment.

(3) What happens if I do not follow my WorkFirst requirements?

If you do not participate in creating an individual responsibility plan, job search, or in the activities listed in your individual responsibility plan, and you do not have a good reason, the department will follow the sanction rules in WAC 388-310-1600.

AMENDATORY SECTION (Amending WSR 06-08-044, filed 3/30/06, effective 6/1/06)

WAC 388-310-0500 WorkFirst—Individual responsibility plan. (1) What is the purpose of my individual responsibility plan?

The purpose of your individual responsibility plan is to give you a written statement that describes:

- (a) What your responsibilities are; and
- (b) Which WorkFirst activities you are required to participate in; and
- (c) What services you will receive so you are able to participate.

(2) What is included in my individual responsibility plan?

Your individual responsibility plan includes the following:

(a) What WorkFirst activities you must do and the participation requirements for those activities including the amount of time you will spend doing the activities, a start and end date for each activity and the requirement to participate fully.

(b) Any other specific requirements that are tied to the WorkFirst work activity. For example, you might be required to learn English as part of your work experience activity or to provide proof of your employment hours.

(c) What services we will provide to help you participate in the activity. For example, you may require support services (such as help with paying for transportation) or help with paying childcare.

(d) Your statement that you recognize the need to become and remain employed as quickly as possible.

(3) How is my individual responsibility plan developed?

You and your case manager will work together and use information gathered from your comprehensive evaluation (see WAC 388-310-0700) to develop your individual responsibility plan and decide what activities will be included in it.

Then, your case manager will assign you to specific WorkFirst activities that will help you find employment.

(4) What happens after my individual responsibility plan is completed?

Once your individual responsibility plan is completed:

(a) You will sign and get a copy of your individual responsibility plan.

(b) You and your case manager will review your plan as necessary over the coming months to make sure your plan continues to meet your employment needs. You will sign and get a copy of your individual responsibility plan every time it is reviewed and changed.

(5) What should I do if I cannot go to a required WorkFirst appointment or activity because of a temporary situation outside of my control?

If you cannot participate because of a temporary situation outside of your control, you must call the telephone number shown on your individual responsibility plan on the same day you were to report to explain your situation. You will be given an excused absence. Some examples of excused absences include:

- (a) You, your children or other family members are ill;
- (b) Your transportation or child care arrangements break down and you cannot make new arrangements in time to comply;
- (c) A significant person in your life died; or
- (d) A family violence situation arose or worsened.

(6) What happens if I don't call in on the same day I am unable to attend to get an excused absence?

If you do not call in on the same day you are unable to attend to get an excused absence, it will be considered an unexcused absence.

If you exceed the number of unexcused absences allowed on your individual responsibility plan, without good cause, your case manager will begin the sanction process. (See WAC 388-310-1600 for more details.)

AMENDATORY SECTION (Amending WSR 06-08-044, filed 3/30/06, effective 6/1/06)

WAC 388-310-0600 WorkFirst—Job search. (1) What is job search?

Job search is an opportunity to learn and use skills you need to find and keep a job. Job search may include:

- (a) Classroom instruction; and/or
- (b) Structured job search that helps you find job openings, complete applications, practice interviews and apply other skills and abilities with a job search specialist or a group of fellow job-seekers(~~and/or~~
- ~~(c) Preemployment training; and/or~~
- ~~(d) High wage/high demand training.~~

(2) What is preemployment training?

~~Preemployment training helps you learn skills you need for an identified entry level job that pays more than average entry level wages.~~

~~(a) Preemployment training is an acceptable job search activity when an employer or industry commits to hiring or giving hiring preference to WorkFirst participants who successfully complete preemployment training.~~

(b) You can find out about current preemployment training opportunities by asking your job service specialist, your case manager or staff at your local community and technical college.

~~(3) What is high-wage/high-demand training?~~

~~(a) There are two types of high-wage/high-demand (HWHD) full-time training options for TANF recipients to complete a certificate or degree that will lead to employment in a high-wage/high-demand occupation:~~

~~(i) Information technology, health care or other professional technical programs: This option allows you to start and finish a one-year or shorter state community or technical college training program in the information technology, health care fields or other professional technical programs that meet high-wage high-demand criteria; and/or~~

~~(ii) Certificate/degree completion: This option allows you to finish up the last year of any certificate or degree program in a high-wage/high-demand field on an exception basis. The high-wage/high-demand criteria for this option is based on median income and high-demand occupations within the local labor market as determined by employment security department.~~

~~(b) For both types of HWHD training, the training can be approved one time only (barring an approved exception to policy). There is no work requirement with either option for the twelve months of training time.~~

~~(c) To qualify for HWHD training, you must also:~~

~~(i) Meet all of the prerequisites for the course;~~

~~(ii) Obtain the certificate or degree within twelve calendar months;~~

~~(iii) Participate full time in the training program and make satisfactory progress;~~

~~(iv) Work with collocated ESD staff during the last quarter of training for job placement; and~~

~~(v) Return to job search once you complete the educational program if still unemployed).~~

~~((4)) (2) Who provides me with job search?~~

You get job search from the employment security department or another organization under contract with WorkFirst to provide these services.

~~((5)) (3) How long do I stay in job search?~~

Periods of job search will start with a review of the work skills assessment portion of your comprehensive evaluation and may last up to twelve continuous weeks. Job search specialists will monitor your progress. By the end of the first four weeks, a job search specialist will determine whether you should continue in job search. Job search will end when:

(a) You find a full-time job; or

(b) You become exempt from WorkFirst requirements (see WAC 388-310-0300); or

(c) Your situation changes and the case manager changes the activities on your IRP to fit your new circumstances (see WAC 388-310-0400); or

(d) After fully participating in job search, and based on your experience in looking for work in the local labor market, it is determined that you need additional skills and/or experience to find a job; or

(e) You have not found a job at the end of the job search period.

~~((6)) (4) What happens at the end of job search if I have not found a job?~~

At the end of each job search period, you will be referred back to your case manager who will, at a minimum, review and update the DSHS portion of your comprehensive evaluation if you have not found a job. You and your case manager will also modify your individual responsibility plan.

AMENDATORY SECTION (Amending WSR 06-08-048, filed 3/30/06, effective 5/1/06)

WAC 388-310-0900 WorkFirst—Basic education. (1) What is basic education?

Basic education is high school completion, classes to prepare for general equivalency diploma (GED), testing to acquire GED certification, adult basic education (ABE) or English as a second language (ESL) training. Basic education also includes supervised homework and study activities associated with the educational activity.

(2) When do I participate in basic education as part of WorkFirst?

You may participate in basic education as part of WorkFirst under any of the following circumstances:

(a) You are twenty years of age or older and your comprehensive evaluation shows you need this education to become employed or get a better job and:

(i) You are ~~((enrolled in an approved WorkFirst work activity for at least))~~ participating the equivalent of twenty hours or more per week in job search, vocational education, issue resolution, paid work or unpaid work that meets the federal definition of core activities; or

(ii) You have ~~((fully participated in job search without finding a job))~~ limited-English proficiency and you lack language skills that are needed to qualify for entry level jobs.

(b) You may be required to participate if you are a mandatory participant, a parent eighteen or nineteen years of age, you do not have a high school diploma or GED certificate and you need this education in order to find employment.

(c) You will be required to be in high school or a GED certification program if you are a mandatory participant, sixteen or seventeen years old and you do not have a high school diploma or GED certificate.

(d) ~~((Employment security department (ESD) has determined that you are a seasonal worker (that is, your usual pattern of employment is based on recurring cycle of seasonal employment). Under WorkFirst, seasonal workers qualify for full-time education and training during the off season.~~

~~((e))~~ You are enrolled in the pregnancy to employment pathway and your comprehensive evaluation shows basic education would help you find and keep employment. (See WAC 388-310-1450.)

AMENDATORY SECTION (Amending WSR 06-08-048, filed 3/30/06, effective 5/1/06)

WAC 388-310-1000 WorkFirst—Vocational education. (1) What is vocational education?

Vocational education is training that leads to a degree or certificate in a specific occupation, not to result in a baccalaureate or advanced degree unless otherwise indicated below, and is offered by an accredited:

- (a) Public and private technical college or school;
- (b) Community college; ~~((e))~~
- (c) Tribal college; or

(d) For customized job skills training (formerly known as pre-employment training), community based organizations.

(2) Vocational education may include:

(a) Customized job skills training;

(b) High-wage/high-demand training;

(c) Supervised homework and study activities associated with the educational activity; and/or

(d) Remedial/developmental education, prerequisites, basic education and/or English-as-a-Second Language training deemed a necessary part of the vocational education program.

(3) What is customized job skills training?

Customized job skills training helps you learn skills you need for an identified entry level job that pays more than average entry level wages.

(a) Customized job skills training is an acceptable activity when an employer or industry commits to hiring or giving hiring preference to WorkFirst participants who successfully complete customized job skills training.

(b) You can find out about current customized job skills training opportunities by asking your employment services counselor, your case manager or staff at your local community and technical college.

(4) What is high-wage/high-demand training?

(a) There are two types of high-wage/high-demand (HWHD) full-time training options for TANF recipients to complete a certificate or degree that will lead to employment in a high-wage/high-demand occupation:

(i) Information technology, health care or other professional-technical programs: This option allows you to start and finish a one-year or shorter state community or technical college training program in the information technology, health care fields or other professional-technical programs that meet high-wage/high-demand criteria; and/or

(ii) Certificate/degree completion: This option allows you to finish up the last year of any certificate or degree program, not to exceed a baccalaureate degree, in a high-wage/high-demand field on an exception basis. The high-wage/high-demand criteria for this option is based on median income and high-demand occupations within the local labor market as determined by employment security department.

(b) For both types of HWHD training, the training can be approved one-time only (barring an approved exception to policy).

(c) To qualify for HWHD training, you must also:

(i) Meet all of the prerequisites for the course;

(ii) Obtain the certificate or degree within twelve calendar months;

(iii) Participate full time in the training program and make satisfactory progress;

(iv) Work with WorkFirst staff during the last quarter of training for job placement; and

(v) Return to job search once you complete the educational program if still unemployed.

((2)) (5) When can vocational education be included in my individual responsibility plan?

We may add vocational education to your individual responsibility plan for up to twelve months if:

(a) Your comprehensive evaluation shows you need this education to become employed or get a better job and you participate full time in vocational education or ~~((by combining))~~ combine vocational education with any approved WorkFirst work activity; or

~~(b) ((Employment security department (ESD) has determined that you are a seasonal worker (that is, your usual pattern of employment is based on a recurring cycle of seasonal employment). Under WorkFirst, seasonal workers qualify for full-time education and training during the off season; or~~

~~((e))~~ You are in an internship or practicum for up to twelve months that is paid or unpaid and required to complete a course of vocational training or to obtain a license or certificate in a high demand ~~((field, as determined by the employment security department))~~ program; or

~~((d))~~ (c) You have limited English proficiency and you lack job skills that are in demand for entry level jobs in your area; and the vocational education program is the only way that you can acquire ~~((the job))~~ these skills ~~((you need to qualify for entry level jobs in your area))~~ (because there is no available work experience, ~~((preemployment training))~~ community service or on-the-job training that can teach you these skills); or

~~((e))~~ (d) You are in the pregnancy to employment pathway and your comprehensive evaluation shows vocational education would help you find and keep employment. (See WAC 388-310-1450.)

~~((3))~~ **(6) Can I get help with paying the costs of vocational education?**

WorkFirst may pay for the costs of your vocational education, such as tuition or books, for up to twelve months, if vocational education is in your individual responsibility plan and there is no other way to pay them. You may also get help with paying your child care costs through the working connections child care program. (See chapter 388-290 WAC for the working connections child care program rules.)

AMENDATORY SECTION (Amending WSR 02-15-067, filed 7/11/02, effective 8/1/02)

WAC 388-310-1050 WorkFirst—~~((Job skills))~~ Skills Enhancement training. (1) **What is ~~((job))~~ skills enhancement training?**

~~((Job skills))~~ Skills enhancement training ~~((formerly known as job skills training))~~ is training ~~((in specific skills directly related to employment, but not tied to a specific occupation. Job skills training programs are generally short term, but differ in what skills are taught and who provides the training.))~~ or education for job skills required by an employer to provide a person with the ability to obtain employment or to advance or adapt to the changing demands of the workplace. Skills enhancement training may include:

(a) Customized training programs to meet the needs of a specific employer;

(b) General education and training that prepares a person for employment to include vocational education and courses explicitly required for program entry;

(c) Basic education and English as a second language training when such instruction is focused on skills needed for employment, combined in a unified whole with job training or needed to enable the person to perform a specific job or engage in a specific job training program;

(d) Four-year bachelor degree programs at any state-certified college or university; and

(e) Supervised homework and study activities.

(2) Who may provide skills enhancement training?

The training may be offered by the following types of organizations that meet the WorkFirst program's standards for service providers:

(a) Community based organizations;

(b) Businesses;

(c) Tribal governments; or

(d) Public and private community and technical colleges.

~~((2))~~ **(3) When can ~~((job))~~ skills enhancement training be included in my individual responsibility plan?**

We may add ~~((job))~~ skills enhancement training in your individual responsibility plan if(~~(=~~

~~(a))~~ you are ~~((working))~~ participating the equivalent of twenty or more hours a week in job search, vocational education, issue resolution, paid ~~((unsubsidized))~~ work or unpaid work~~(~~(=~~~~

~~(b) You are working sixteen or more hours per week in a federal or state work study position; or~~

~~(c) You are working in a subsidized job, like a community jobs position, at least twenty hours per week; or~~

~~(d) Employment security department (ESD) has determined that you are a seasonal worker (that is, your usual pattern of employment is based on a recurring cycle of seasonal employment). Under WorkFirst, seasonal workers qualify for full-time education and training during the off season; or~~

~~(e) You lack job skills that are in demand for entry level jobs in your area, and the job skills training is short term and is combined with job search)) that meets the federal definition of core activities.~~

~~((3))~~ **(4) Can I get help with paying the ~~((costs of))~~ skills enhancement training?**

WorkFirst may pay your costs, such as tuition or books, if ~~((job))~~ skills enhancement training is in your individual responsibility plan and there is no other way to pay them. You may also get help with paying your child care costs through the working connections child care program. (See chapter 388-290 WAC for the working connections child care program rules.)

AMENDATORY SECTION (Amending WSR 99-10-027, filed 4/28/99, effective 5/29/99)

WAC 388-310-1100 WorkFirst—Work experience.

(1) What is work experience?

Work experience (sometimes called WEX) is an activity for mandatory participants that will teach you the basics of holding down a job and give you a chance to practice or expand your work skills. Work experience teaches you these skills by assigning you to unpaid work with:

(a) A private, nonprofit organization;

(b) A community or technical college; ~~((or))~~

(c) A federal, state, local or tribal government or district; or

(d) Any entity providing an internship or practicum as described in WAC 388-310-1000 (2)(b).

(2) What happens when I am enrolled in a work experience activity?

When you are enrolled in a work experience activity:

(a) The organization, government or district that is supervising your work experience position must comply with all applicable state and federal health and safety standards while you are working there.

(b) You may be required to look for work on your own and must accept any paid employment you find that meets the criteria in WAC 388-310-1500.

(3) How long does a work experience assignment last?

Your case manager must review your work experience assignment if it lasts longer than six months. This review will determine whether you need more time to learn the skills and abilities that the work experience assignment was set up to teach you.

AMENDATORY SECTION (Amending WSR 05-13-030, filed 6/3/05, effective 7/4/05)

WAC 388-310-1400 WorkFirst—Community service. (1) What is community service?

Community service ~~((includes two types of activities for mandatory participants:~~

~~(a))~~ is unpaid work (such as the work performed by volunteer workers) that you perform for a charitable nonprofit organization, federal, state, local or tribal government or district~~(~~(=~~~~

~~(b) An activity approved by your case manager which benefits you, your family, your community or your tribe. These activities may include)), including traditional activities that perpetuate tribal culture and customs.~~

(2) What ~~((type of community service(s))~~ other activities may be approved, even though they are not considered community service, because they benefit me, my family, my community or my tribe and might be included in my individual responsibility plan?

The following types ~~((of community service))~~ activities may be approved, even though they are not considered community service, because they benefit you, your family, your community or your tribe and might be included in your individual responsibility plan:

(a) Caring for a disabled family member;

(b) Caring for a child, if you are fifty-five years old or older and receiving TANF or SFA assistance for the child as a relative (instead of as the child's parent);

(c) Providing childcare for another WorkFirst participant who is doing community service;

(d) Actively participating in a drug or alcohol assessment or treatment program which is certified or contracted by the state under chapter 70.96A RCW;

(e) Participating in family violence counseling or drug or alcohol treatment that will help you become employable or keep your job (this is called "specialized services" in state law);

- (f) Participating in the pregnancy to employment pathway; and/or
- (g) Job preparation.

AMENDATORY SECTION (Amending WSR 04-05-010, filed 2/6/04, effective 3/8/04)

WAC 388-310-1500 WorkFirst—Employment conditions. (1) If I am a mandatory participant, are there any limitations on the type of paid or unpaid employment I must accept?

If you are a mandatory participant, you must accept paid or unpaid employment (including any activity in which an employer-employee relationship exists) unless the employment:

- (a) Is not covered by industrial insurance (described in state law under Title 51 RCW) unless you are employed by a tribal government or a tribal private for-profit business;
- (b) Is available because of a labor dispute;
- (c) Has working hours or conditions that interfere with your religious beliefs or practices (and a reasonable accommodation cannot be made);
- (d) Does not meet federal, state or tribal health and safety standards; or
- (e) Has unreasonable work demands or conditions, such as working for an employer who does not pay you on schedule.

(2) Are there any additional limitations on when I can be required to accept paid employment?

You must accept paid employment unless the job or the employer:

- (a) Pays less than the federal, state, or tribe minimum wage, whichever is higher;
- (b) Does not provide unemployment compensation coverage (described in state law under Title 50 RCW) unless you:
 - (i) Work for a tribal government or tribal for-profit business; or
 - (ii) Are a treaty fishing rights related worker (and exempt under section 7873 of the Internal Revenue code);
- (c) Requires you to resign or refrain from joining a legitimate labor organization; or
- (d) Does not provide you benefits that are equal to those provided to other workers employed in similar jobs.

(3) How many hours of unpaid employment can I be required to perform?

You can be required to work a set number of hours of unpaid employment each month. The number of hours required will not be more than your TANF, SFA or GA-S cash grant plus Basic Food benefits, divided by the state (~~or federal~~) minimum wage(~~(, whichever is higher)~~).

(4) What safeguards are in place to make sure I am not used to displace currently employed workers?

The following safeguards are in place to make sure you are not used to displace currently employed workers:

- (a) You cannot be required to accept paid or unpaid employment which:
 - (i) Results in another employee's job loss, reduced wages, reduced hours of employment or overtime or lost employment benefits;

(ii) Impairs existing contracts for services or collective bargaining agreements;

(iii) Puts you in a job or assignment, or uses you to fill a vacancy, when:

(A) Any other person is on lay off from the same (or very similar) job within the same organizational unit; or

(B) An employer ends the job of a regular employee (or otherwise reduces its workforce) so you can be hired.

(iv) Reduces current employees' opportunities for promotions.

(b) If a regular employee believes your subsidized or unpaid work activity (such as a community jobs or work experience position) violates any of the rules described above, this employee (or his or her representative) has the right to:

(i) A grievance procedure (described in WAC 388-426-0005); and

(ii) A fair hearing (described in chapter 388-02 WAC).

(5) What other rules apply specifically to subsidized or on-the-job training positions?

If you are in a subsidized or on-the-job training position:

(a) WorkFirst state agencies must stop paying your wage or on-the-job training subsidy to your employer if your employer's worksite or operation becomes involved in a strike, lockout or bona fide labor dispute.

(b) If your wage subsidy or on-the-job training agreement is ended (and we stop paying any subsidies to your employer) because you were used to displace another employee, it will be up to you and the employer to decide whether you can (or want to) keep working there.

AMENDATORY SECTION (Amending WSR 02-15-067, filed 7/11/02, effective 8/1/02)

WAC 388-310-1700 WorkFirst—Self-employment.

(1) What is self-employment?

When you work for yourself and do not have an employer, you are self-employed.

(2) When can I be deferred from job search to pursue self-employment?

(a) To be deferred from job search for self-employment, you must meet all the conditions below:

(i) You must be working at least thirty-two hours a week at your business;

(ii) Your business must generate income for you that is equal to the federal minimum wage (~~((state or federal, whichever is higher)))~~) times thirty-two hours per week after your business expenses are subtracted.

(iii) Your case manager will refer you to a local business resource center, and they must approve your self-employment plan;

(b) If you do not meet all these conditions, you can still be self-employed, but you will also need to participate in job search or other WorkFirst activities.

(3) What self-employment services can I get?

If you are a mandatory participant and have an approved self-employment plan in your individual responsibility plan, you may get the following self-employment services:

(a) A referral to community resources for technical assistance with your business plan.

(b) Small business training courses through local community organizations or technical and community colleges.

(c) Information on affordable credit, business training and ongoing technical support.

(4) What support services may I receive?

If you have an approved self-employment plan in your individual responsibility plan all support services are available.

(5) Can I get childcare?

Childcare is available if you have an approved self-employment plan in your individual responsibility plan. (See chapter 388-290 WAC for working connections child care rules.)

WSR 08-01-027

PROPOSED RULES

BOARD OF ACCOUNTANCY

[Filed December 10, 2007, 9:48 a.m.]

Original Notice.

Preproposal statement of inquiry was filed as WSR 07-16-121.

Title of Rule and Other Identifying Information: WAC 4-25-750 What are the firm licensing requirements?

Hearing Location(s): Hilton Seattle Airport & Conference Center, Peninsula Room, 17620 International Boulevard, SeaTac, WA, on January 25, 2008, at 9:00 a.m.

Date of Intended Adoption: January 25, 2008.

Submit Written Comments to: Richard C. Sweeney, Executive Director, P.O. Box 9131, Olympia, WA 98507-9131, e-mail webmaster@cpaboard.wa.gov, fax (360) 664-9190, by January 15, 2008.

Assistance for Persons with Disabilities: Contact Cheryl Sexton by January 11, 2008, TTY (800) 833-6384 or (360) 664-9194.

Purpose of the Proposal and Its Anticipated Effects, Including Any Changes in Existing Rules: To align the rule with the Public Accountancy Act, chapter 18.04 RCW, and RCW 25.15.045 professional limited liability companies, and clarify ownership requirements for CPA firms. The board is also proposing other minor housekeeping language amendments.

Reasons Supporting Proposal: CPAs are continually asking: If they as an individual register as a professional limited liability company or a professional corporation, may be [the] professional limited liability company or professional corporation be an owner in a CPA firm. RCW 18.04.195 requires that a simple majority of the ownership of the licensed firm in terms of financial interests and voting rights of all owners shall be held by natural persons who are licensees or holders of a valid license issued under the Public Accountancy Act or by another state that entitles the holder to practice public accounting in this state. WAC 4-25-410(29) defines "natural person" as a living human being. A professional limited liability company or a professional corporation does not seem to fit this definition. But, the professional limited liability statute, RCW 25.15.045 allows a professional corporation or another professional limited liability company to be a member of a professional limited liability company.

This statute and the Public Accountancy Act seem to be in conflict. To bring the board's rule in line with the professional limited liability company statute, the board is proposing to allow professional limited liability companies or professional corporations to be registered owners of CPA firms provided the professional limited liability company or professional corporation is registered with the board as a CPA firm and all owners of the professional limited liability company or professional corporation are licensed CPAs as required by RCW 25.15.045.

Statutory Authority for Adoption: RCW 18.04.055(8), 18.04.195, 18.04.205.

Statute Being Implemented: RCW 18.04.055(8), 18.04.195, 18.04.205.

Rule is not necessitated by federal law, federal or state court decision.

Name of Proponent: Primarily the Washington state board of accountancy, governmental.

Name of Agency Personnel Responsible for Drafting, Implementation and Enforcement: Richard C. Sweeney, CPA, Executive Director, (360) 586-0163.

No small business economic impact statement has been prepared under chapter 19.85 RCW. The proposed rule will not have more than minor economic impact on business.

A cost-benefit analysis is not required under RCW 34.05.328. The board of accountancy is not one of the agencies required to submit to the requirements of RCW 34.05.328.

December 6, 2007

Richard C. Sweeney
Executive Director

AMENDATORY SECTION (Amending WSR 05-01-137, filed 12/16/04, effective 1/31/05)

WAC 4-25-750 What are the CPA firm licensing requirements? With the exception of out-of-state sole practicing CPAs holding valid practice privileges in Washington state under WAC 4-25-756, attest services may only be offered or performed ~~((#))~~ **by** a CPA firm licensed by the board and meeting the requirements of this section. An entity wishing to use "CPA(s)" or "certified public accountant(s)" in the firm name must first obtain a license from the board.

(1) **How may a CPA firm be organized?** A CPA firm may be organized as:

- (a) A proprietorship;
- (b) A partnership;
- (c) A professional corporation (PC) or professional service corporation (PS);
- (d) A limited liability company (LLC);
- (e) A limited liability partnership (LLP); or
- (f) Any other form of legal entity authorized by statute for use by a CPA firm.

(2) **What happens when a CPA firm alters its legal form?** A change in the legal form of a firm constitutes a new firm. Accordingly, the new entity must first obtain a CPA firm license from the board.

(3) **What are the ownership requirements for a CPA firm?**

- (a) All owners of a licensed CPA firm are required to:

(i) Be natural persons including CPA firms licensed in this state and organized as a professional limited liability company or as a professional corporation owned entirely by living human beings who are licensees in this state or holders of a valid license to practice public accountancy issued by another state;

(ii) Fully comply with the provisions of chapter 18.04 RCW; and

(iii) Be subject to discipline by the board for violations of chapter 18.04 RCW or 4-25 WAC;

(b) A simple majority of the ownership of the licensed firm in terms of financial interests and voting rights of all partners, owners, or shareholders must be:

(i) Licensees in this state or holders of a valid license to practice public accountancy issued by another state;

(ii) Entitled to practice public accounting in Washington state; and

(iii) Principally employed by the corporation or actively engaged in its business.

(c) At least one general partner of a partnership, one shareholder of a corporation, and one (~~manager~~) member of a limited liability company must be a licensee.

(d) Each CPA proprietor, partner, shareholder or (~~manager~~) member who is either a resident or is entering the state and practicing public accountancy in this state must hold a valid Washington state license or practice privileges.

(e) The principal partner of the partnership and any partner having authority over issuing reports on financial statements must be a licensee under the act or holder of a valid license to practice public accountancy issued by another state and must be entitled to practice public accounting in this state.

(f) The principal officer of the corporation and any officer or director having authority over issuing reports on financial statements must be a licensee under the act or holder of a valid license to practice public accountancy issued by another state and must be entitled to practice public accountancy in this state.

(g) The (~~principal manager or~~) managing member of a limited liability company and any member having authority over issuing reports on financial statements must be a licensee under the act or holder of a valid license to practice public accountancy issued by another state and must be entitled to practice public accountancy in this state.

(h) A nonresident CPA owner must be licensed to practice public accountancy in at least one state.

(i) A nonlicensee owner must:

(i) Be a natural person as defined by RCW 18.04.025;

(ii) Meet the good character requirements of RCW 18.04.105 (1)(a);

(iii) Comply with the act and board rules; and

(iv) Be an active individual participant in the licensed firm or affiliated entities as these terms are defined in WAC 4-25-410; and

(j) A resident nonlicensee firm owner must meet the requirements of WAC 4-25-752 and register with the board concurrent with submission of the firm license, or submission of an amendment to the firm license, to the board.

(4) **What are the requirements for the firm's main office and a branch office?** (~~The~~) A firm's main office

located in this state must be under the direct supervision of a resident licensee.

A branch office is an office of a licensed CPA firm which is physically separated from the main office. A branch office operates under the (~~CPA firm~~) license of the main office.

(5) How do I apply for an initial CPA firm license?

To apply for an initial CPA firm license you must use the application form(s) provided by the board and submit the completed form(s), all applicable fees, and all required documentation including the following to the board's office:

(a) The firm name;

(b) Address and telephone number of the main office and any branch offices of the firm;

(c) Name of the managing licensee of the main office;

(d) Licensee owners' names and the states in which they hold CPA licenses;

(e) Name(s) of all nonlicensee owners;

(f) Complete registration form(s), including the appropriate fee, for each resident nonlicensee owner; and

(g) Type of legal organization under which the firm operates.

An application is not complete and cannot be processed until all fees, required information, and required documentation is received by the board. Upon completion of processing, a CPA firm license will be mailed to the main office at the last address provided to the board.

The initial CPA firm license will expire on June 30 of the third calendar year following initial licensure.

(6) How do I renew a CPA firm license? To renew a CPA firm license you must use the form(s) provided by the board. In January of the year of expiration, a renewal form(s) will be mailed to the main office at the last address provided to the board. You must submit a properly completed renewal form(s), all applicable fees and all required documentation to the board by April 30th of the year of expiration. Failure to file a complete renewal form for a firm license by April 30 of the year of expiration will result in late fees. The board may waive, reduce, or extend the due date of renewal and/or late fees based on individual hardship including, but not limited to, financial hardship, critical illness, or active military deployment. A renewal application is not complete and cannot be processed until all fees, required information, and required documentation is received by the board. Upon completion of processing, the CPA firm license will be mailed to the main office at the last address provided to the board.

The CPA firm license will expire on June 30 of the third calendar year following the date of renewal.

(7) When must I notify the board of changes in the CPA firm? A CPA firm must provide the board written notification of the following within ninety days of its occurrence:

(a) Dissolution of a CPA firm;

(b) The occurrence of any event that would cause the firm to be in violation of RCW 18.04.195 or this rule; or

(c) An event that requires an amendment to a firm license.

(8) What events require a firm amendment? A CPA firm must provide written notification to the board, by submitting a firm amendment form and the appropriate amend-

ment fee, within ninety days of the following events' occurrence:

- (a) Admission or departure of an owner;
- (b) Any change in the name of the firm; or
- (c) Change in the managing licensee of the main office.

(9) **How long do I have to correct noncompliance with licensure requirements due to a change in ownership or an owner's credentials?** A CPA firm must notify the board within ninety days of any change in ownership or lapse of an owner's license, certificate, registration or practice privilege that has caused the firm's license to be out of compliance with licensure requirements and must correct the noncompliance within ninety days of the lapse, unless the board grants a longer time period due to individual hardship including, but not limited to, financial hardship, critical illness, or active military deployment.

WSR 08-01-028
PROPOSED RULES
OLYMPIC COLLEGE

[Filed December 10, 2007, 11:08 a.m.]

Original Notice.

Preproposal statement of inquiry was filed as WSR 07-21-039 [07-21-038].

Title of Rule and Other Identifying Information: Animal control policy, this is a new policy for Olympic College that governs the control of pets and other animals on and in all campuses and buildings owned or controlled by Olympic College.

Hearing Location(s): Olympic College Board Room, Fifth Floor, College Service Center, 1600 Chester Avenue, Bremerton, WA 98337, on January 29, 2008, at 3:00 p.m.

Date of Intended Adoption: January 29, 2008.

Submit Written Comments to: Thomas Oliver, Olympic College, CSC 210, 1600 Chester Avenue, Bremerton, WA 98337, e-mail toliver@olympic.edu, fax (360) 475-7502, by January 11, 2008.

Assistance for Persons with Disabilities: Contact Karen Fusco by January 7, 2008, TTY (360) 475-7543 or (360) 457-7542 [475-7542].

Purpose of the Proposal and Its Anticipated Effects, Including Any Changes in Existing Rules: This policy will provide a clear outline of Olympic College policy regarding animals on all of its campuses. To date, no other written policy on this issue exists. Having a written policy will facilitate consistent treatment of animals on the campus and afford security appropriate authority when and if circumstances require action.

Reasons Supporting Proposal: The lack of a clear policy has caused confusion and inconsistency in dealing with animal control on the Olympic College campuses. This policy provides appropriate rules for animal control to assure a safe campus and learning environment.

Statutory Authority for Adoption: Chapter 28B.50 RCW.

Statute Being Implemented: Chapter 28B.50 RCW.

Rule is not necessitated by federal law, federal or state court decision.

Name of Proponent: College Council, Olympic College, governmental.

Name of Agency Personnel Responsible for Drafting: Candace Alvarez, College Council President, 1600 Chester Avenue, Bremerton, WA 98337, (360) 475-7322; Implementation: Thomas Oliver, 1600 Chester Avenue, Bremerton, WA 98337, (360) 475-7502; and Enforcement: Safety and Security, 1600 Chester Avenue, Bremerton, WA 98337, (360) 475-7800.

No small business economic impact statement has been prepared under chapter 19.85 RCW. There will be no impact on any entity other than Olympic College.

A cost-benefit analysis is not required under RCW 34.05.328. There is no significant economic impact.

December 13 [10], 2007

Thomas Oliver

Rules Coordinator

NEW SECTION

WAC 132C-10-041 Animal control policy. (1) This section governs the control of pets and other animals on and in all campuses and buildings owned or controlled by Olympic College.

(2) Except as provided herein, no person may bring an animal into a building owned or controlled by the college. This provision shall not apply to or prohibit a service animal as defined under RCW 49.60.040 (23) and (24), an animal under the control of a law enforcement officer, or an animal authorized by the college for educational purposes.

(3) Animals are permitted on the campus grounds only when under the direct control of their owners or keepers. Direct control for this purpose means control by means of a leash, cage, bridle, or other restraining device held by the owner or keeper, except that reasonable modifications of this provision may be made to accommodate a service animal.

(4) No animal whether on the campus grounds or in a college building, shall be permitted to run at large, to disrupt the college's programs or activities, or to pose a direct threat to the health or safety of others.

(5) Any violation of this section will be cause for removal of the violator and/or animal from campus and/or disciplinary action against the violator. An animal found in violation of this section may also be subject to impoundment under city or county animal control ordinances. Violations may be reported to campus security; however, community support is urged in reminding pet owners of their obligation if a violation is observed by a community member.

(6) A student or employee who is responsible for an animal that is repeatedly in violation of this section may be subject to the disciplinary proceedings appropriate to his or her status. Visitors to campus who are responsible for an animal that repeatedly fails to comply with this section may be subject to legal process.

(7) Brief adjudicative proceedings under RCW 34.05.-482 through 34.05.494, shall be used in all matters relating to the college's enforcement of this section.

WSR 08-01-029
PROPOSED RULES
OLYMPIC COLLEGE

[Filed December 10, 2007, 11:27 a.m.]

Original Notice.

Preproposal statement of inquiry was filed as WSR 07-21-039.

Title of Rule and Other Identifying Information: Revision of college seal, WAC 132C-104-040.

Hearing Location(s): Olympic College Board Room, Fifth Floor, College Service Center, 1600 Chester Avenue, Bremerton, WA 98337, on January 29, 2008, at 3:00 p.m.

Date of Intended Adoption: January 29, 2008.

Submit Written Comments to: Thomas Oliver, Olympic College, CSC 210, 1600 Chester Avenue, Bremerton, WA 98337, e-mail toliver@olympic.edu, fax (360) 475-7502, by January 11, 2008.

Assistance for Persons with Disabilities: Contact Karen Fusco by January 7, 2008, TTY (360) 475-7543 or (360) 457-7542 [475-7542].

Purpose of the Proposal and Its Anticipated Effects, Including Any Changes in Existing Rules: This revised rule updates the official Olympic College seal to include reference to Mason County in addition to Kitsap County. Both counties are included in Olympic College District #3. The new seal spells out the word Washington, in place of the prior abbreviated form. In addition, the rule expands the use of the seal to include Olympic College promotional uses.

Reasons Supporting Proposal: The seal would be modernized, and would more accurately reflect the district. Permission to use the seal for promotion would help create better visibility for the college.

Statutory Authority for Adoption: Chapter 28B.50 RCW.

Statute Being Implemented: Chapter 28B.50 RCW.

Rule is not necessitated by federal law, federal or state court decision.

Name of Proponent: Thomas Oliver, Olympic College rules coordinator, governmental.

Name of Agency Personnel Responsible for Drafting, Implementation and Enforcement: Thomas Oliver, 1600 Chester Avenue, Bremerton, WA 98337, (360) 475-7502.

No small business economic impact statement has been prepared under chapter 19.85 RCW. There will be no impact on any entity other than Olympic College.

A cost-benefit analysis is not required under RCW 34.05.328. There is no significant economic impact.

December 13 [10], 2007

Thomas Oliver
 Rules Coordinator

AMENDATORY SECTION (Amending Order 4433, filed 1/24/74)

WAC 132C-104-040 Seal. (1) Design. The seal of Olympic College shall be the following form and design:

((STRICKEN GRAPHIC



STRICKEN GRAPHIC))



(2) Use. The seal shall be used only in connection with the transaction of official business of Olympic College or for promotional purposes.

WSR 08-01-038
PROPOSED RULES
DEPARTMENT OF
FINANCIAL INSTITUTIONS
 [Filed December 10, 2007, 10:38 p.m.]

Original Notice.

Preproposal statement of inquiry was filed as WSR 07-07-114.

Title of Rule and Other Identifying Information: Amending the rules in chapter 208-660 WAC, implementing the Mortgage Broker Practices Act, chapter 19.146 RCW.

Hearing Location(s): Renton City Hall, 1055 South Grady Way, Renton, WA 98055, on January 30, 2008, at 1:00 p.m. to 3:00 p.m.

Date of Intended Adoption: February 20, 2008.

Submit Written Comments to: Cindy Fazio, P.O. Box 41200, 150 Israel Road, Olympia, WA 98504-1200, e-mail lfazio@dfi.wa.gov, fax (360) 586-5068, by January 25, 2008.

Assistance for Persons with Disabilities: Contact Cindy Fazio by January 25, 2008, TTY (360) 664-8126 or (360) 902-8786.

Purpose of the Proposal and Its Anticipated Effects, Including Any Changes in Existing Rules: The purpose of the rule amendments is to clarify the department's interpretation of the law. The changes include, but are not limited to: Addition of the definition of advertising material, addition of a federal law reference to the definition of federal laws, addition of the definition of underwriting, clarifying the following: License requirements of independent contractor loan originators who work for exempt entities, exemption for lenders under Fannie Mae and Freddie Mac programs, the use of DBA names, requirements for supervisory plans for branch offices, licensing requirements for designated brokers, financial background requirements for licensees, required tests for designated brokers, requirements for loan originators working for more than one mortgage broker, requirements for loan originators who get paid by escrow at closing, inactive licenses, continuing education requirements for loan originators, changing the date for submission of the mortgage broker annual report, disclosing the YSP, refunding fees to borrowers, providing a clear written explanation with redisclosures, failing to disclose under TILA, advertising using a borrower's current loan information, disclosing the APR, adoption of federal guidance, fee adjustments, report requirements of continuing education providers and consequences of failure to report, and technical corrections.

Reasons Supporting Proposal: To clarify the department's interpretation of chapter 19.146 RCW.

Statutory Authority for Adoption: RCW 43.320.040.

Statute Being Implemented: Chapter 19.146 RCW.

Rule is not necessitated by federal law, federal or state court decision.

Name of Proponent: Department of financial institutions, governmental.

Name of Agency Personnel Responsible for Drafting, Implementation and Enforcement: Cindy Fazio, 150 Israel Road, Olympia, WA, (360) 902-8800.

No small business economic impact statement has been prepared under chapter 19.85 RCW. The rule amendments will not impose more than minor costs on the businesses impacted by the proposed rules.

A cost-benefit analysis is not required under RCW 34.05.328. Not applicable to the proposed rules.

December 11 [10], 2007

Deborah Bortner, Director
Division of Consumer Services

AMENDATORY SECTION (Amending WSR 06-23-137, filed 11/21/06, effective 1/1/07)

WAC 208-660-006 Definitions. What definitions are applicable to these rules? Unless the context clearly requires otherwise, the definitions in this section apply throughout these rules.

"Act" means the Mortgage Broker Practices Act, chapter 19.146 RCW.

"Advertising material" means any form of sales or promotional materials (~~(to be)~~) used in connection with the mortgage broker business. Advertising material includes, but is not limited to, newspapers, magazines, leaflets, flyers, direct mail, indoor or outdoor signs or displays, point-of-sale litera-

ture or educational materials, other printed materials; radio, television, public address system, or other audio broadcasts; or internet pages.

"Affiliate" means any person who directly or indirectly through one or more intermediaries, controls, or is controlled by, or is under common control with another person.

"Application" means the same as in Regulation X, Real Estate Settlement Procedures, 24 C.F.R. Sec. 3500 as of the effective date of these rules, which is the submission, whether written or computer-generated, of a borrower's financial information in anticipation of a credit decision relating to a residential mortgage loan. If the submission does not state or identify a specific property, the submission is an application for a prequalification and not an application for a residential mortgage loan under this part. The subsequent addition of an identified property to the submission converts the submission to an application for a residential mortgage loan.

For a refinance or purchase application that is not a prequalification, the credit report may be enough to constitute an application. The credit report date determines when the mortgage broker, or loan originator on behalf of the mortgage broker, has gathered sufficient information to make a credit decision. This may be a trigger for early disclosures when the property address is known.

"Appraisal" means the act or process of developing an opinion of value, the act pertaining to an appraisal-related function, or any verbal or written opinion of value offered by an appraiser. The opinion of value by the appraiser includes any communication that is offered as a single point, a value range, a possible value range, exclusion of a value, or a minimum value.

"Borrower" means any person who consults with or retains a mortgage broker or loan originator in an effort to obtain or seek advice or information on obtaining or applying to obtain a residential mortgage loan for himself, herself, or persons including himself or herself, regardless of whether the person actually obtains such a loan.

"Branch office" means a fixed physical location such as an office, separate from the principal place of business of the licensee, where the licensee holds itself out as a mortgage broker.

"Branch office license" means a branch office license issued by the director allowing the licensee to conduct a mortgage broker business at the location indicated on the license.

"Certificate of passing an approved examination" means a certificate signed by the testing administrator verifying that the individual performed with a satisfactory score or higher.

"Certificate of satisfactory completion of an approved continuing education course" means a certificate signed by the course provider verifying that the individual has attended an approved continuing education course.

"Compensation or gain" means remuneration, benefits, or an increase in something having monetary value, including, but not limited to, moneys, things, discounts, salaries, commissions, fees, duplicate payments of a charge, stock, dividends, distributions of partnership profits, franchise royalties, credits representing moneys that may be paid at a future date, the opportunity to participate in a money-making

program, retained or increased earnings, increased equity in a parent or subsidiary entity, special or unusual bank or financing terms, services of all types at special or free rates, sales or rentals at special prices or rates, lease or rental payments based in whole or in part on the amount of business referred, trips and payments of another person's expenses, or reduction in credit against an existing obligation. "Compensation or gain" is not evaluated solely on a loan by loan basis.

For example, a realtor advertising that buyers using their services will receive free loan origination assistance is doing so in the anticipation of "compensation or gain" through increased real estate business.

"Computer loan information systems" or "CLI system" means a real estate mortgage financing information system that facilitates the provision of information to consumers by a mortgage broker, loan originator, lender, real estate agent, or other person regarding interest rates and other loan terms available from different lenders.

For purposes of this definition, the CLI system includes computer hardware or software, an internet-based system, or any combination of these, which provides information to consumers about residential mortgage interest rates and other loan terms which are available from another person.

"Computer loan information system provider" or "CLI provider" is any person who provides a computer loan information service, either directly, or as an owner-operator of a CLI system, or both.

"Consumer Protection Act" means chapter 19.86 RCW.

"Control" including the terms "controls," "is controlled by," or "is under common control" means the power, directly or indirectly, to direct or cause the direction of the management or policies of a person, whether through ownership of the business, by contract, or otherwise. A person is presumed to control another person if such person is:

- A general partner, officer, director, or employer of another person;
- Directly or indirectly or acting in concert with others, or through one or more subsidiaries, owns, holds with power to vote, or holds proxies representing, more than twenty per cent of the voting interests of another person; or
- Has similar status or function in the business as a person in this definition.

"Convicted of a crime," irrespective of the pronouncement or suspension of sentence, means a person:

- Has been convicted of the crime in any jurisdiction;
- Has been convicted of a crime which, if committed within this state would constitute a crime under the laws of this state;
- Has plead guilty or no contest or nolo contendere or stipulated to facts that are sufficient to justify a finding of guilt to such a charge before a court or federal magistrate; or
- Has been found guilty of a crime by the decision or judgment of a state or federal judge or magistrate, or by the verdict of a jury.

"Department" means the department of financial institutions.

"Designated broker" means a natural person designated as the person responsible for activities of the licensed mortgage broker in conducting the business of a mortgage broker

under this chapter and who meets the experience and examination requirements set forth in RCW 19.146.210 (1)(e).

"Director" means the director of financial institutions.

"Discount points" or "points" mean a fee paid by a borrower to a lender to reduce the interest rate of a residential mortgage loan. Pursuant to Regulation X, discount points are to be reflected on line 802 of the good faith estimate and settlement statement as a percentage of the loan amount.

"Division of consumer services" means the division of consumer services within the department of financial institutions, or such other division within the department delegated by the director to oversee implementation of the act and these rules.

"Employee" means an individual who has an employment relationship with a mortgage broker, and the individual is treated as an employee by the mortgage broker for purposes of compliance with federal income tax laws.

"Examination" or "compliance examination" means the examination performed by the division of consumer services, or such other division within the department delegated by the director to oversee implementation of the act and these rules to determine whether the licensee is in compliance with applicable laws and regulations.

Federal statutes and regulations used in these rules are:

- "Alternative Mortgage Transaction Parity Act" means the Alternative Mortgage Transaction Parity Act (AMTPA), 12 U.S.C. Sec. 3801 et seq.
- "Equal Credit Opportunity Act" means the Equal Credit Opportunity Act (ECOA), 15 U.S.C. Sec. 1691 et seq., Regulation B, 12 C.F.R. Part 202.
- "Fair Credit Reporting Act" means the Fair Credit Reporting Act (FCRA), 15 U.S.C. Sec. 1681 et seq.
- "Federal Trade Commission Act" means the Federal Trade Commission Act, 15 U.S.C. Sec. 45(a).
- "Gramm-Leach-Bliley Act (GLBA)" means the ~~((Gramm-Leach-Bliley Act (GLBA)))~~ Financial Modernization Act of 1999, ((#)) 15 U.S.C. Sec. 6801-6809, and the GLBA-mandated Federal Trade Commission (FTC) privacy rules, at 16 C.F.R. Parts 313-314.
- "Home Equity Loan Consumer Protection Act" means the Home Equity Loan Consumer Protection Act, 15 U.S.C. Sec. 1637 and 1647.
- "Home Mortgage Disclosure Act" means the Home Mortgage Disclosure Act (HMDA), 12 U.S.C. Sec. 2801-2810, Regulation C, 12 C.F.R. Part 203.
- "Home Ownership and Equity Protection Act" means the Home Ownership and Equity Protection Act (HOEPA), 15 U.S.C. Sec. 1639.
- "Homeowners Protection Act" means the Homeowners Protection Act of 1998 (HPA), 12 U.S.C. Sec. 4901 et seq.
- "Real Estate Settlement Procedures Act" means the Real Estate Settlement Procedures Act (RESPA), 12 U.S.C. Sec. 2601 et seq., Regulation X, 24 C.F.R. Part 3500 et seq.
- "Telemarketing and Consumer Fraud and Abuse Prevention Act" means the Telemarketing and Consumer Fraud and Abuse Prevention Act, 15 U.S.C. Sec. 6101-6108, Telephone Sales Rule, 16 C.F.R. Part 310.
- "Truth in Lending Act" means the Truth in Lending Act (TILA), 15 U.S.C. Sec. 1601 et seq., Regulation Z, 12 C.F.R. Part 226 et seq.

"Federally insured financial institution" means a savings bank, savings and loan association, or credit union, whether state or federally chartered, or a federally insured bank, authorized to conduct business in this state.

"Financial misconduct," for the purposes of the act, means a criminal conviction for any of the following:

- Any conduct prohibited by the act;
- Any conduct prohibited by statutes governing mortgage brokers in other states, or the United States, if such conduct would constitute a violation of the act;
- Any conduct prohibited by statutes governing other segments of the financial services industry, including but not limited to the Consumer Protection Act, statutes governing the conduct of securities broker dealers, financial advisers, escrow officers, title insurance companies, limited practice officers, trust companies, and other licensed or chartered financial service providers; or
- Any conduct commonly known as white collar crime, including, but not limited to, embezzlement, identity theft, mail or wire fraud, insider trading, money laundering, check fraud, or similar crimes.

"Independent contractor" means any person that expressly or impliedly contracts to perform mortgage brokering services for another and that with respect to its manner or means of performing the services is not subject to the other's right of control, and that is not treated as an employee by the other for purposes of compliance with federal income tax laws.

The following factors may be considered to determine if a person is an independent contractor:

Is the person instructed about when, where and how to work?

Is the person guaranteed a regular wage?

Is the person reimbursed for business expenses?

Does the person maintain a separate business?

Is the person exposed to potential profits and losses?

Is the person provided employee benefits such as insurance, a pension plan, or vacation or sick pay?

"Licensee" means:

- A mortgage broker licensed by the director; or
- The principal(s) or designated broker of a mortgage broker; or
- A loan originator licensed by the director; or
- Any person subject to licensing under RCW 19.146.200; or
- Any person acting as a mortgage broker or loan originator subject to any provisions of the act.

"License application fee" means immediately available funds paid to the department for each mortgage broker, loan originator, or mortgage broker branch office license application.

"Loan application" means the same as "application," in this section.

"Loan originator" means a natural person who:

- Takes a residential mortgage loan application for a mortgage broker; or
- Offers or negotiates terms of a mortgage loan, for direct or indirect compensation or gain, or in the expectation of direct or indirect compensation or gain. "Loan originator" also includes a person who holds themselves out to the public

as able to perform any of these activities. "Loan originator" does not mean persons performing purely administrative or clerical tasks for a mortgage broker. For the purposes of this subsection, "administrative or clerical tasks" means the receipt, collection, and distribution of information common for the processing of a loan in the mortgage industry and communication with a borrower to obtain information necessary for the processing of a loan. A person who holds himself or herself out to the public as able to obtain a loan is not performing administrative or clerical tasks.

For purposes of further defining "loan originator," "taking a residential mortgage loan application" includes soliciting, accepting, or offering to accept an application for a residential mortgage loan or assisting a borrower or offering to assist a borrower in the preparation of a residential mortgage loan application.

For purposes of this definition, a person "holds themselves out" by advertising or otherwise informing the public that the person engages in any of the activities of a mortgage broker or loan originator, including the use of business cards, stationery, brochures, rate lists or other promotional items.

"Loan originator licensee" means a natural person who is licensed as a loan originator or is subject to licensing under RCW 19.146.200 or who is acting as a loan originator subject to any provisions of the act.

"Loan processor" means a natural person who performs clerical or support duties at the direction of and subject to the supervision and instruction of a licensed or exempt mortgage broker. The job responsibilities may include the receipt, collection and distribution of information common for the processing of a loan. The loan processor may also communicate with a borrower to obtain the information necessary for the processing of a loan, provided that such communication does not include offering or negotiating loan rates or terms, or counseling borrowers about loan rates or terms.

"Lock-in agreement" means an agreement with a borrower made by a mortgage broker or loan originator, in which the mortgage broker or loan originator agrees that, for a period of time, a specific interest rate or other financing terms will be the rate or terms at which it will make a loan available to that borrower.

"Mortgage broker" means any person who for compensation or gain, or in the expectation of compensation or gain:

- Makes a residential mortgage loan or assists a person in obtaining or applying to obtain a residential mortgage loan; or
- Holds himself or herself out as being able to make a residential mortgage loan or assist a person in obtaining or applying to obtain a residential mortgage loan.

For purposes of this definition, a person "makes" a loan if: The loan is closed in their name, or they advance, offer to advance or make a commitment to advance funds to a borrower for a loan.

For purposes of this definition, a person "assists a person in obtaining or applying to obtain a residential mortgage loan" by, among other things, counseling on loan terms (rates, fees, other costs), preparing loan packages, or collecting enough information on behalf of the consumer to anticipate a credit decision under Regulation X, 24 C.F.R. Part 3500, Sec. 3500.2(b).

For purposes of this definition, a person "holds themselves out" by advertising or otherwise informing the public that they engage in any of the activities of a mortgage broker or loan originator, including the use of business cards, stationery, brochures, rate lists, or other promotional items.

"Mortgage broker licensee" means a person that is licensed as a mortgage broker or is subject to licensing under RCW 19.146.200 or is acting as a mortgage broker subject to any provisions of the act.

"Mortgage Broker Practices Act" means chapter 19.146 RCW.

"Out-of-state applicant or licensee" means a person subject to licensing that maintains an office outside of this state.

"Person" means a natural person, corporation, company, limited liability corporation, partnership, or association.

"Prepaid escrowed costs of ownership," as used in RCW 19.146.030(4), means any amounts prepaid by the borrower for the payment of taxes, property insurance, interim interest, and similar items in regard to the property used as security for the loan.

"Principal" means any person who controls, directly or indirectly through one or more intermediaries, or alone or in concert with others, a ten percent or greater interest in a partnership, company, association, or corporation, and the owner of a sole proprietorship.

"Registered agent" means a person located in Washington appointed to accept service of process for a licensee.

"Residential mortgage loan" means any loan primarily for personal, family, or household use secured by a mortgage or deed of trust on residential real estate upon which is constructed or intended to be constructed a single family dwelling or multiple family dwelling of four or less units.

For purposes of this definition, a loan "primarily for personal, family, or household use" includes loan applications for a finance or refinance of a primary residence for any purpose, loan applications on second homes, and loan applications on nonowner occupied residential real estate provided the licensee has knowledge that proceeds of the loan are intended to be used primarily for personal, family or household use.

"Residential real estate" is real property upon which is constructed or intended to be constructed, a single family dwelling or multiple family dwelling of four or less units.

• Residential real estate includes, but is not limited to:

- A single family home;
- A duplex;
- A triplex;
- A fourplex;
- A single condominium in a condominium complex;
- A single unit within a cooperative;
- A manufactured home when the home and real property together will secure the residential mortgage loan; or
- A fractional, fee simple interest in any of the above.

• Residential real estate does not include:

- An apartment building or dwelling of five or more units;
- A single piece of real estate with five or more single family dwellings unless each dwelling is capable of being financed independently of the other dwellings; or

– Any dwelling on leased or rented land or space, such as dwellings in a manufactured home park unless the mortgage broker treats such property as residential real estate.

"Table-funding" means a settlement at which a mortgage loan is funded by a contemporaneous advance of loan funds and an assignment of the loan to the person advancing the funds. The mortgage broker originates the loan and closes the loan in its own name with funds provided contemporaneously by a lender to whom the closed loan is assigned.

"Third-party provider" means any person other than a mortgage broker or lender who provides goods or services to the mortgage broker in connection with the preparation of the borrower's loan and includes, but is not limited to, credit reporting agencies, title companies, appraisers, structural and pest inspectors, or escrow companies.

A lender is considered a third party only when the lender provides lock-in arrangements to the mortgage broker in connection with the preparation of a borrower's loan.

"Underwriting" means a lender's detailed credit analysis preceding the offering or making of a loan. The analysis may be based on information furnished by the borrower (employment history, salary, financial statements), the borrower's credit history from a credit report, the lender's evaluation of the borrower's credit needs and ability to pay, and an assessment of the collateral for the loan. While mortgage brokers may have access to various automated underwriting systems to facilitate an evaluation of the borrower's qualifications, the mortgage broker who qualifies or approves a borrower in this manner is not the underwriter of the loan and cannot charge a fee for underwriting the loan. Third-party charges the mortgage broker incurs in using or accessing an automated system to qualify or approve a borrower may, like other third-party expenses, be passed on to the borrower.

AMENDATORY SECTION (Amending WSR 06-23-137, filed 11/21/06, effective 1/1/07)

WAC 208-660-007 Good standing. (1) What does good standing mean? For the purposes of the act and these rules, good standing means that the applicant, licensee, or other person subject to the act demonstrates financial responsibility, character, and general fitness sufficient to command the confidence of the community and to warrant a belief that the business will be operated honestly, fairly, and efficiently within the purposes of the act and these rules. In determining good standing the director will consider the following factors, and any other evidence relevant to good standing as defined in this rule:

(a) Whether the applicant or licensee has paid all fees due to the director.

(b) Whether the licensee has filed their mortgage broker annual report.

(c) Whether the licensee has filed and maintained the required surety bond or had its surety bond canceled or revoked for cause.

(d) Whether the licensee has maintained a designated broker in compliance with the act and these rules.

(e) Whether the applicant, licensee, or other person subject to the act has had any license, or any authorization or ability to do business under any similar statute of this or any

other state, suspended, revoked, or restricted within the prior five years.

(f) Whether the applicant, licensee, or other person subject to the act has been convicted of a ~~((felony, or a))~~ gross misdemeanor involving dishonesty or financial misconduct, or a felony, within the prior seven years.

(g) Whether the licensee or other person subject to the act, is, or has been subject to a cease and desist order or an injunction issued pursuant to the act, or the Consumer Protection Act, or has been found through an administrative, civil, or criminal proceeding to have violated the provisions of the act or rules, or the Consumer Protection Act, chapter 19.86 RCW.

(h) Whether the director has filed a statement of charges, or there is an outstanding order by the director to cease and desist against the licensee or other person subject to the act.

(i) Whether there is documented evidence of serious or significant complaints filed against the licensee, or other person subject to the act, and the licensee or other person subject to the act has been notified of the complaints and been given the opportunity to respond.

(j) Whether the licensee has allowed the licensed mortgage broker business to deteriorate into a condition that would result in denial of a new application for a license.

(k) Whether the licensee, or other person subject to the act has failed to comply with an order, directive, subpoena, or requirement of the director or director's designee, or with an assurance of discontinuance entered into with the director or director's designee.

(l) Whether the licensee or other person subject to the act has interfered with an investigation or disciplinary proceeding by willful misrepresentation of facts before the director or director's designee, or by the use of threats or harassment against a client, witness, employee of the licensee, or representative of the director for the purpose of preventing them from discovering evidence for, or providing evidence in, any disciplinary proceeding or other legal action.

(2) Under what circumstances may the department conduct a good standing review of an applicant, mortgage broker licensee, designated broker, or exempt mortgage broker? The department may conduct a good standing review when:

(a) Processing an application for a new mortgage broker branch office license.

(b) Processing an application for appointment of a different designated broker (both the licensed mortgage broker, including those individuals to whom the license was granted, and the proposed designated broker must meet good standing).

(c) Processing a request for recognition as an exempt mortgage broker under RCW 19.146.020(4).

(3) When will an applicant, licensee, or other person subject to the act receive notice from the department of their failure to meet a determination of good standing? The department will notify the applicant, licensee, or other person subject to the act that they have failed to meet the department's good standing requirement within ten business days of the department's receipt of any application or request that requires a determination of good standing. See subsection (2) of this section.

(4) What recourse does an applicant, licensee, or other person subject to the act have when the department has determined that they are not in good standing? The applicant, licensee, or other person subject to the act may request a brief adjudicative proceeding under the Administrative Procedure Act, chapter 34.05 RCW, to challenge the department's determination.

(5) What department determinations may be challenged through a brief adjudicative proceeding? Subsection (1)(a) through (l) of this section may be challenged through a brief adjudicative process.

(6) What specific sections of the Administrative Procedure Act are adopted by the director to administer brief adjudicative proceedings? The director adopts RCW 34.05.482 through 34.05.494 to administer brief adjudicative proceedings requested by an applicant or licensee, or conducted at the director's discretion.

(7) Who conducts the brief adjudicative proceeding? Brief adjudicative proceedings are conducted by a presiding officer designated by the director. The presiding officer must have department expertise in the subject matter, but must not have personally participated in the department's determination of good standing, or work in the department's division of consumer services, or such other division within the department delegated by the director to oversee implementation of the act and these rules.

(8) When and how will the presiding officer issue a decision? Within ten business days of the final date for submission of materials, or oral argument, if any, the presiding officer must make a written initial order.

AMENDATORY SECTION (Amending WSR 06-23-137, filed 11/21/06, effective 1/1/07)

WAC 208-660-008 Exemption from licensing. (1) If I am licensed as an insurance agent under RCW 48.17.060, must I have a separate license to act as a loan originator or mortgage broker? Yes. You will need a separate license as a loan originator or mortgage broker if you are a licensed insurance agent and you do any of the following:

(a) Take a residential mortgage loan application for a mortgage broker;

(b) Offer or negotiate terms of a mortgage loan for direct or indirect compensation or gain, or in the expectation of direct or indirect compensation or gain;

(c) Make a residential mortgage loan, or assist a person in obtaining or applying to obtain a residential mortgage loan, for compensation or gain; or

(d) Hold yourself out as being able to perform any of the above services.

(2) Are insurance companies exempt from the Mortgage Broker Practices Act? Yes. Insurance companies authorized to transact the business of insurance in this state by the Washington state office of the insurance commissioner are exempt from the Mortgage Broker Practices Act.

(3) If I make residential mortgage loans under the Consumer Loan Act, chapter 31.04 RCW, am I exempt from the Mortgage Broker Practices Act? If you are licensed under the Consumer Loan Act, ~~((any loans covered by that act))~~ only residential mortgage loans are exempt from

the Mortgage Broker Practices Act. Complying with the Consumer Loan Act includes abiding by the requirements and restrictions of that act and counting all loans originated and made under that act for purposes of your annual assessment.

(4) If I make residential mortgage loans under the Consumer Loan Act, chapter 31.04 RCW, are my loan originators exempt from the Mortgage Broker Practices Act? Your loan originator employees are also exempt from the Mortgage Broker Practices Act for their loan originator activities on residential mortgage loans.

Your independent contractor loan originators are not exempt from the Mortgage Broker Practices Act for their residential mortgage loan originator activities.

(5) If I am an exempt mortgage broker because my business has been approved by and is subject to audit by Fannie Mae or Freddie Mac, am I subject to licensing or any other sections of the act? You are not required to have a license to make loans that you sell to Fannie Mae or Freddie Mac, but you are subject to RCW 19.146.0201 through 19.146.080, and the rules associated with those sections of the act. Those sections include prohibited practices, certain required disclosures, the requirement of a writing for agreements, trust fund requirements, books and records requirements, limitations on fees or compensation, and the requirement to provide the consumer with certain information they have paid for. You are also subject to the investigation and enforcement authority of the director.

Stated another way, if your mortgage business does not make and then sell all loans to Fannie Mae or Freddie Mac, you must have a license to broker or make the residential mortgage loans not sold to Fannie Mae or Freddie Mac.

((5)) (6) If I am an exempt mortgage broker because my business has been approved by and is subject to audit by Fannie Mae or Freddie Mac, are my loan originators subject to licensing or any other sections of the act? Your loan originator employees are not required to have a license to conduct loan originator activities on loans made and then sold to Fannie Mae or Freddie Mac, but they are subject to RCW 19.146.0201 through 19.146.080, and the rules associated with those sections of the act. Those sections include prohibited practices, certain required disclosures, the requirement of a writing for agreements, trust fund requirements, books and records requirements, limitations on fees or compensation, and the requirement to provide the consumer with certain information they have paid for. Your loan originator employees are also subject to the investigation and enforcement authority of the director.

Your loan originators must be licensed to act as loan originators on residential mortgage loans not made and then sold to Fannie Mae or Freddie Mac.

Your independent contractor loan originators are not exempt under this section.

((6)) (7) Am I exempt from the Mortgage Broker Practices Act if I make or acquire residential mortgage loans solely with my own funds for my own investment without intending to resell the residential mortgage loans? You are exempt from the licensing requirements, but you are subject to RCW 19.146.0201 through 19.146.080, and the rules associated with those sections of the act. Those sections include prohibited practices, certain required disclo-

tures, the requirement of a writing for agreements, trust fund requirements, books and records requirements, limitations on fees or compensation, and the requirement to provide the consumer with certain information they have paid for. You are also subject to the investigation and enforcement authority of the director.

For purposes of this section, intent to resell residential mortgage loans is determined by your ability and willingness to hold the residential mortgage loans, indicated by, but not limited to, such measures as whether you have sold loans in the past, whether the loans conform to established secondary market standards for the sale of loans, and whether your financial condition would reasonably allow you to hold the residential mortgage loans.

((7)) (8) If I am an exempt mortgage broker because I am making or acquiring residential mortgage loans solely with my own funds for my own investment without intending to resell the residential mortgage loans, are my loan originators subject to licensing or any other sections of the act? Your loan originator employees are not required to have a license, but they are subject to RCW 19.146.0201 through 19.146.080, and the rules associated with those sections of the act. Those sections include prohibited practices, certain required disclosures, the requirement of a writing for agreements, trust fund requirements, books and records requirements, limitations on fees or compensation, and the requirement to provide the consumer with certain information they have paid for. Your loan originator employees are also subject to the investigation and enforcement authority of the director.

Your independent contractor loan originators are not exempt under this section.

((8)) (9) As an attorney, must I have a mortgage broker or loan originator license to assist a person in obtaining or applying to obtain a residential mortgage loan in the course of my practice?

(a) If you are an attorney licensed in Washington and if the mortgage broker activities are incidental to your professional duties as an attorney, you are exempt from the Mortgage Broker Practices Act under RCW 19.146.020 (1)(c).

(b) Whether an exemption is available to you depends on the facts and circumstances of your particular situation. For example, if you hold yourself out publicly as being able to perform the services of a mortgage broker or loan originator, or if your fee structure for those services is different from the customary fee structure for your professional legal services, the department will consider you to be principally engaged in the mortgage broker business and you will need a mortgage broker or loan originator license before performing those services. A "customary" fee structure for the professional legal service does not include the receipt of compensation or gain associated with obtaining a residential mortgage loan on the property.

((9)) (10) As a licensed real estate broker or salesperson, must I have a mortgage broker or loan originator license when I assist the purchaser in obtaining financing for a residential mortgage loan involving a bona fide sale of real estate? You are exempt from the act under RCW 19.146.020 (1)(g) if you only receive the customary real estate commission in connection with the transaction. A "cus-

tomary" real estate commission does not include receipt of compensation or gain associated with the financing of the property. A "customary" real estate commission only includes the agreed upon commission designated in the listing or purchase and sale agreement for the bona fide sale of the subject property.

~~((10))~~ **(11) Under what circumstances will the director approve an exemption under RCW 19.146.020(4) for the exclusive agents working as loan originators of an affiliate of a bank that is wholly owned by the bank holding company that owns that bank?**

(a) The director will provide a written exemption from loan originator licensing for the exclusive agents of an affiliate of a bank that is wholly owned by the bank holding company that owns the bank if the director finds that the affiliate is licensed and is in "good standing" with the department and the affiliate has procedures in place, as evidenced by a written "plan of business," to reasonably assure the department that:

(i) The exclusive agents of the affiliate of a bank operate exclusively as loan originators for the affiliate and not for other mortgage brokers;

(ii) The affiliate of the bank requires continuing education for the exclusive agents that meets the same or similar requirements approved by the director for licensed loan originators;

(iii) The affiliate of the bank will notify the department if the affiliate terminates an exclusive agent because the exclusive agent:

(A) Has had any license, or any authorization to do business under any similar statute of this or any other state, suspended, revoked, or restricted within the prior five years; or

(B) Has been convicted of a felony, or a gross misdemeanor involving dishonesty or financial misconduct, within the prior seven years; or

(C) Has been subject to a cease and desist order or an injunction issued pursuant to the act, or the Consumer Protection Act, or has been found through an administrative, civil, or criminal proceeding to have violated the provisions of the act or rules, or the Consumer Protection Act, chapter 19.86 RCW.

(b) To qualify for this exemption, the affiliate must make a written request to the department and submit a "plan of business" with the request. After receipt of this request, the department will notify the affiliate in writing within ten business days whether the affiliate's exclusive agents qualify for the exemption, or if the department will conduct additional review of the affiliate and the "plan of business." The affiliates must receive the department's notice of qualification for exemption before the affiliate's exclusive agents take any action that would subject them to licensing under the act.

(c) The exemption granted by the director remains valid as long as the affiliate complies in all material respects with its "plan of business" and the affiliate remains in good standing with the department.

~~((11))~~ **(12) What are the responsibilities of a mortgage broker that is exempt from the licensing provisions of the act?** The owners of companies exempt from licensing under RCW 19.146.020 (1)(e), (g), or (4), are responsible for:

(a) Complying with RCW 19.146.0201 through 19.146.-080, and 19.146.235;

(b) Ensuring compliance with the act by all persons representing the exempt mortgage broker; and

(c) Notifying the director of any change affecting the mortgage broker's exempt status under the act.

~~((12))~~ **(13) Are the independent contractors of a mortgage broker exempt under RCW 19.146.020 (1)(b), (c), (e), and (g) themselves exempt?** No. After January 1, 2007, an independent contractor working as a loan originator for a mortgage broker exempt under RCW 19.146.020 (1)(b), (c), (e), and (g) must hold a loan originator license.

~~((13))~~ **(14) What other persons or entities are exempt from the Mortgage Broker Practices Act?**

(a) Any person doing any act under order of any court except for a person subject to an injunction to comply with any provision of the act or any order of the director issued under the act.

(b) The United States of America, the state of Washington, any other state, and any Washington city, county, or other political subdivision, and any agency, division, or corporate instrumentality of any of the entities in this subsection (b).

~~((14))~~ **(15) When is a CLI provider exempt from the licensing requirements of the act?** A CLI provider is exempt from the licensing requirements of the act:

(a) When the CLI provider meets the general statutory requirements under RCW 19.146.020 (1)(a), (c), (d), (e), (g), or (h); or

(b) When a real estate broker or salesperson licensed in Washington, acting as a CLI provider and a real estate agent, obtains financing for a real estate transaction involving a bona fide sale of real estate and does not receive either:

(i) A separate fee for the CLI service; or

(ii) A sales commission greater than that which would be otherwise customary in connection with the sales transaction; or

(c) When a person, acting as a CLI provider:

(i) Provides only information regarding rates, terms, and lenders;

(ii) Complies with all requirements of subsection (16) of this section;

(iii) Does not represent or imply to a borrower that they are able to obtain a residential mortgage loan from a mortgage broker or lender;

(iv) Does not accept a loan application, assist in the completion of a loan application, or submit a loan application to a mortgage broker or lender on behalf of a borrower;

(v) Does not accept any deposit for third-party provider services or any loan fees from a borrower in connection with a loan, regardless of when the fees are paid;

(vi) Does not negotiate interest rates or terms of a loan with a mortgage broker or lender on behalf of a borrower; and

(vii) Does not provide to the borrower a good faith estimate or other disclosure(s) required of mortgage brokers or lender(s) by state or federal law.

(d) If the CLI provider is not exempt under (a), (b), or (c) of this subsection, the CLI provider is not required to have a mortgage broker license if the CLI provider does not receive

any fee or other compensation or gain, directly or indirectly, for performing or facilitating the CLI service.

~~((15))~~ **(16) When is a CLI provider required to have a mortgage broker license?**

(a) If a CLI provider, who is not otherwise exempt from the licensing requirements of the act, performs any act that would otherwise require that they be licensed, including accepting a loan application, or submitting a loan application to a mortgage broker or lender, the CLI provider must obtain a mortgage broker license.

(b) Example - License required: A CLI provider uses an internet-based CLI system in which an abbreviated application is available for online completion by borrower. Once the borrower presses "submit," the information collected in the abbreviated application is forwarded to lender. The information contains the borrower's name, Social Security number, contact information, purpose of the loan sought (e.g., purchase, refinance, home equity, second mortgage), size of loan requested, annual salary, and a self-declaration of total unsecured debt. The electronic entries made by the borrower are then used by lender to electronically populate "form fields" and to initiate lender's loan application. A loan originator for the lender then follows up with borrower to complete the loan application. On or after closing, CLI provider receives a CLI service fee.

(c) Example - License not required: A CLI provider uses an internet-based CLI system in which various interactive informational tools are present, including an online "prequalification" tool. Based upon borrower's self-declared data input, borrower receives an indication of borrower's "maximum affordable loan amount," based upon standard norms of debt-to-income ratio and loan-to-value ratio, and also subject to verification of information, availability and suitability of loan products, and independent underwriting by any lender. The borrower indicates a desire for follow-up from one or more lenders by inputting personal contact information and pressing "submit." A number of lenders receive only the personal identity information of borrower and not any financial information. However, the CLI system has been programmed (and may be continuously reprogrammed) to route personal contact information to certain lenders based upon borrower's "prequalification" data input and the lending criteria of each of the lenders for whom CLI provider has a relationship. None of borrower's self-declared financial information is actually submitted to any of the lenders whose criteria match borrower's profile. Loan originators from lender A and lender B initiate contact with borrower based solely on borrower's contact information. Lender A and lender B, through their assigned loan originators, contact borrower with the object of beginning and hopefully completing a loan application. In this example, CLI provider has not taken a loan application.

~~((16))~~ **(17) Must the CLI provider provide any disclosures?**

(a) Yes. If a borrower using or accessing the CLI services pays for the CLI service, either directly or indirectly, the CLI provider must give the following disclosure:

(i) The amount of the fee the CLI provider charges the borrower for the service;

(ii) That the use of the CLI system is not required to obtain a residential mortgage loan; and

(iii) That the full range of loans available may not be listed on the CLI system, and different terms and conditions, including lower rates, may be available from others not listed on the system.

(b) Each CLI provider must give the borrower a copy of the disclosure form when the first CLI service is provided to the borrower. The form must be signed and dated by the borrower and a copy maintained as part of the CLI provider's books and records for at least two years.

~~((17))~~ **(18) Are CLI system providers subject to enforcement under the act?** Yes. CLI system providers are responsible for any violations of the act and will be subject to any applicable fines or penalties.

AMENDATORY SECTION (Amending WSR 06-23-137, filed 11/21/06, effective 1/1/07)

WAC 208-660-163 Mortgage brokers—Licensing.

(1) How do I apply for a mortgage broker license?

(a) **Appoint a designated broker.** You must appoint a designated broker who meets the requirements of WAC 208-660-250.

(b) **Submit an application.** You must fill out an application in a form prescribed by the director. Submit the application with the appropriate attachments to the department for review.

(c) **Pay the application and license fees.** You will have to pay an application fee to cover the department's cost of processing and reviewing application. You must also pay a separate annual license fee. See WAC 208-660-550, Department fees and costs.

(d) **Prove your identity.** You must provide information about the identity of owners, principals, officers, and the designated broker, including fingerprints.

(e) **Provide a surety bond.** Mortgage brokers must have a surety bond of twenty to sixty thousand dollars depending on the average number of loan originators representing the mortgage broker. See WAC 208-660-175 (1)(e).

(2) What information will the department consider when deciding whether to approve a mortgage broker license application? The department considers the financial responsibility, character, and general fitness of the applicant, principals, and the designated broker.

(3) Why does the department consider financial responsibility, character, and general fitness before issuing a mortgage broker license? One of the purposes of the act is to ensure that mortgage brokers and loan originators deal honestly and fairly with the public. Applicants, principals, and designated brokers who have demonstrated their financial responsibility, character, and general fitness to operate their businesses honestly, fairly, and efficiently are more likely to deal honestly and fairly with the public.

(4) What specific information will the department consider to determine if the mortgage broker business will be operated honestly, fairly, and in compliance with applicable law?

(a) Whether the applicant, licensee, or other person subject to the act has had any license, or any authorization to do business under any similar statute of this or any other state, suspended, revoked, or restricted within the prior five years.

(b) Whether the applicant, licensee or other person subject to the act has been convicted of a ~~((felony, or a))~~ gross misdemeanor involving dishonesty or financial misconduct, or a felony, within the prior seven years.

(c) Whether the licensee or other person subject to the act is, or has been, subject to a cease and desist order or an injunction issued pursuant to the act, or the Consumer Protection Act, or has been found through an administrative, civil, or criminal proceeding to have violated the provisions of the act or rules, or the Consumer Protection Act, chapter 19.86 RCW.

(d) Whether the director has filed a statement of charges, or there is an outstanding order by the director to cease and desist against the licensee or other person subject to the act.

(e) Whether there is documented evidence of serious or significant complaints filed against the licensee, or other person subject to the act, and the licensee or other person subject to the act has been notified of the complaints and been given the opportunity to respond.

(f) Whether the licensee has allowed the licensed mortgage broker business to deteriorate into a condition that would result in denial of a new application for a license.

(g) Whether the licensee or other person subject to the act has failed to comply with an order, directive, subpoena, or requirement of the director or director's designee, or with an assurance of discontinuance entered into with the director or director's designee.

(h) Whether the licensee or other person subject to the act has interfered with an investigation, or disciplinary proceeding by willful misrepresentation of facts before the director or director's designee, or by the use of threats or harassment against a client, witness, employee of the licensee, or representative of the director for the purpose of preventing them from discovering evidence for, or providing evidence in, any disciplinary proceeding or other legal action.

(5) What will happen if my mortgage broker license application is incomplete? The department will reject and return the entire application package to you with a notice identifying the incomplete, missing, or inaccurate information. You must follow the department's directions to correct the problems. You can then resubmit the application package.

(6) How do I withdraw my application for a mortgage broker license? Send the department a written request, in a form prescribed by the department, to withdraw your mortgage broker license application.

(7) When will the department consider my mortgage broker license application package abandoned? If you do not respond to the department within ten business days from the date of the department's second request for information, your application is considered abandoned. You may reapply by submitting a new application per subsection (1) of this section.

(8) What are my rights if the director denies my application for a mortgage broker license? You have the right to request an administrative hearing pursuant to the Administrative Procedure Act, chapter 34.05 RCW. To request a hearing, you must notify the department within twenty days from the date of the director's notice to you that your license application has been denied, that you wish to have a hearing.

Upon denial of your mortgage broker license application, and provided the department finds no unlicensed activity, the department will return your surety bond, and refund the license fee and any unused portion of the application fee.

(9) What Washington law protects my rights when my application for a mortgage broker license is denied, or my mortgage broker license is suspended or revoked? The Administrative Procedure Act, chapter 34.05 RCW, governs the proceedings for license application denials, cease and desist orders, license suspension or revocation, the imposition of civil penalties or other remedies ordered by the department, and any appeals or reviews of those actions.

(10) May I advertise my business while I am waiting for my mortgage broker license application to be processed? No. It is a violation of the act for nonlicensed, non-exempt mortgage brokers or loan originators to hold themselves out as mortgage brokers or loan originators in Washington.

(11) May I originate Washington residential mortgage loans while waiting for my mortgage broker license application to be processed? No. You may not originate loans prior to receiving your mortgage broker license.

(12) How do I change information on my mortgage broker license? You must file a license amendment application with the department, in a form prescribed by the department. You must file the amendment application within thirty days of the change occurring.

(13) When does a mortgage broker license expire? The mortgage broker license expires annually. The expiration date is shown on the license. If the license is an interim license, it may expire in less than one year.

(14) When may the department issue interim mortgage broker licenses? To prevent an undue delay, the director may issue interim mortgage broker licenses, including branch office licenses, with a fixed expiration date. The license applicant must have substantially met the initial licensing requirements, as determined by the director, to receive an interim license.

For purposes of this section, undue delay includes the adjustment of license expiration or renewal dates to coincide with the implementation of systems designed to assist in licensing uniformity and provide data repositories of licensing information.

One example of having substantially met the initial licensing requirements is: Submitting a complete application, paying all application fees, and the department having received and reviewed the result of the applicant's background check.

(15) May the department issue replacement licenses with an expiration date? Yes. In order to create and maintain a licensing system with expiration or renewal dates that are uniform, the department may issue new licenses with expiration dates to existing license holders. The new licenses will expire annually.

(16) How do I renew my mortgage broker license?

(a) Before the license expiration date you must:

(i) File the mortgage broker annual report, and any other required notices, with the director. See WAC 208-660-400, Reporting requirements.

(ii) Show evidence that your designated broker completed the required annual continuing education.

(iii) Verify the surety bond is adequate for the average number of loan originators, including all locations.

(iv) Pay the annual license assessment fee.

(b) The renewed license is valid for the term listed on the license or until surrendered, suspended, or revoked.

(17) If I let my mortgage broker license expire must I apply to get a new license? If you complete all the requirements for renewal within forty-five days of the expiration date, you may renew an expired license. However, if you renew your license during this forty-five day period, in addition to paying the annual assessment on your license, you must pay an additional fifty percent of your annual assessment. See subsection (16) of this section for the license renewal requirements.

During this forty-five day period, your license is expired and you must not conduct any business under the act that requires a license until your license has been renewed.

Any renewal requirements received by the department must be evidenced by either a United States Postal Service postmark or a department "date received" stamp within the forty-five days. If you fail to comply with the renewal request requirements within forty-five days, you must apply for a new license.

(18) May I still conduct my mortgage broker business if my mortgage broker license has expired? No. If your mortgage broker license expires, you must not conduct any business under the act that requires a license until you renew your license.

(19) What should I do if I wish to close my mortgage broker business? You may surrender the mortgage broker license by notifying the department, in a form prescribed by the department, of your intention to stop doing mortgage loan business in Washington. Surrendering your license does not change your civil or criminal liability, or your liability for any administrative actions arising from any acts or omissions occurring before you surrender your license. Contact the Washington department of revenue to find out how to handle any unclaimed funds in your trust account.

(20) May I transfer, sell, trade, assign, loan, share, or give my mortgage broker license to another person or company? No. A mortgage broker license authorizes only the person named on the license to conduct the business at the location listed on the license. See also WAC 208-660-155(2).

(21) Must I display my mortgage broker license? Yes. Your mortgage broker license must be prominently displayed at the licensed location.

AMENDATORY SECTION (Amending WSR 06-23-137, filed 11/21/06, effective 1/1/07)

WAC 208-660-180 Mortgage brokers—Main office.

(1) Must a licensed mortgage broker have a designated broker? Yes. Licensed mortgage broker companies must have an approved designated broker at all times.

(2) How many designated brokers may a mortgage broker have? The mortgage broker must have a qualified designated broker at all times. The mortgage broker may appoint only one individual to be the designated broker at any

given time. The designated broker need not be a principal of the licensee.

It is a prudent business practice to have more than one qualified individual working for the licensee who could be appointed as the designated broker.

(3) If my designated broker leaves, may I continue to operate my mortgage broker business? Yes. You may continue to operate your mortgage broker business. However, you must notify the department within five business days of the loss of or change of your designated broker. You must then replace the designated broker within thirty days. If you need more than thirty days to replace the designated broker, you must seek approval from the department. Failure to replace your designated broker, or receive approval from the director for an extension, may result in an enforcement action against you.

(4) What must I do to replace my designated broker? You must apply, in a form prescribed by the department, for approval of the new designated broker. The new designated broker must meet the requirements of WAC 208-660-250(1) and the new designated broker and the licensee including those individuals to whom the license was granted, must meet the good standing requirements of WAC 208-660-007.

(5) What must I do if I sell all or part of my mortgage broker company? See WAC 208-660-400(13).

(6) After my mortgage broker license is approved, may I change my business structure? Yes. You must follow the notification requirements of WAC 208-660-400(12).

(7) May a licensed mortgage broker share an office with a licensed real estate broker? Yes. A licensed mortgage broker may share an office with a licensed real estate broker. The mortgage broker location must be licensed as a main or branch mortgage broker office.

(8) If a licensed mortgage broker shares an office with a licensed real estate broker, what must the mortgage broker do to notify the public that the office is shared? The licensed mortgage broker must clearly identify the mortgage broker business as separate from the real estate business to the public on any signage, advertising, or other material identifying the businesses.

(9) May I add a trade name (or "DBA") to my mortgage broker license? Yes. You may add a trade or "DBA" name to the mortgage broker license if you first apply to the department, in a form prescribed by the department, and receive department approval. When the department has approved the trade name, you must conduct business under that trade name in at least one of the two following ways:

(a) Use your license name together with the trade name;

or

(b) Use your mortgage broker license number together with the trade name.

(10) May the department deny an application for a proposed DBA name because it is similar to an existing licensee name? Yes. The director may deny an application for a proposed DBA name if the proposed DBA name is similar to a currently existing licensee name.

(11) May I conduct my mortgage broker business from more than one location? Yes. You may establish one or more branch offices under your license. See WAC 208-660-195 for information on licensing branch offices.

AMENDATORY SECTION (Amending WSR 06-23-137, filed 11/21/06, effective 1/1/07)

WAC 208-660-195 Mortgage brokers—Branch offices. (1) **May I open branch offices under my mortgage broker license?** Yes. A licensed mortgage broker may submit license application(s) to the department to establish branch office(s) under the existing mortgage broker license. Each branch office must be licensed and must pay an annual license fee. See WAC 208-660-550, Department fees and costs.

(2) **If my branch offices are under separate ownership, does that limit my liability for their activities?** No. Licensed mortgage brokers are responsible for the activity and violations at their branch offices regardless of the structure or label given the branch offices. Licensure of a branch office creates a direct line of responsibility from the main office to the branch.

(3) **If my branch offices are under separate ownership, what level of supervision must I maintain?** Because branch offices, regardless of their business structure, are not independent from your license and surety bond, you are responsible for the conduct of anyone conducting business under your license. You must have a written supervisory plan. The details of the plan, and how you implement the plan for your branch offices, must take into account the number of branch offices, their location, and the number of individuals working at the branch offices. You must maintain your written supervisory plan as part of your business books and records.

(4) **How do I apply for a mortgage broker branch office license?** As the licensed mortgage broker, you must apply to the department for a branch office license and receive a branch office license before operating from any location other than your licensed location. The application for a mortgage broker branch office license must be in a form prescribed by the director. The licensed mortgage broker must be in good standing, and may need to increase the amount of the surety bond. You will have to pay application and annual assessment fees. See WAC 208-660-550, Department fees and costs.

~~((4))~~ (5) **What does the department consider when reviewing an application for a branch office license?** The department considers:

(a) Whether the mortgage broker is in good standing. See WAC 208-660-007.

(b) Whether the amount of the mortgage broker's surety bond is sufficient to cover the loan originators that will be working from the branch office.

(c) Whether the physical address listed in the application can be verified as a branch office location.

~~((5))~~ (6) **Must I display my branch office license?** Yes. Your mortgage broker branch office license must be prominently displayed in the branch office.

~~((6))~~ (7) **If I am an internet company, how do I display my license?** You must display your license information, as it appears on your license, including any or all business names, and the license number, on your web site. The information must also include a list of the states in which you are licensed.

~~((7))~~ (8) **How do I change information on my mortgage broker branch office license?** You must file a license amendment application with the department, in a form prescribed by the department. You must file the application within thirty days of the change occurring.

~~((8))~~ (9) **Does my branch office license expire?** The license expires annually. The expiration date is shown on the license. If the license is an interim license, it may expire in less than one year.

~~((9))~~ (10) **How do I renew my mortgage broker branch office license?**

(a) Before the expiration date, the licensed mortgage broker must:

(i) Verify the surety bond is adequate for the licensee's average number of loan originators.

(ii) Pay the branch office annual assessment fee.

(b) The renewed mortgage broker branch office license is valid for the term listed on the license or until surrendered, suspended, or revoked.

~~((10))~~ (11) **If my mortgage broker branch office license expires, must I apply for a new license?** If you complete all the requirements for renewal within forty-five days of the expiration date you may renew an existing license. However, if you renew your license during this forty-five day period, in addition to paying the annual assessment on your branch office license, you must pay an additional fifty percent of your annual assessment for that branch. See subsection ~~((9))~~ (10) of this section for the license renewal requirements.

During this forty-five day period, your license is expired and you must not conduct any business under the act that requires a license until your license has been renewed.

Any renewal requirements received by the department must be evidenced by either a postmark or "date received" stamp within the forty-five days. If you fail to comply with the renewal request requirements within forty-five days, you must apply for a new license.

~~((11))~~ (12) **If my mortgage broker branch office license has expired, may I still conduct my mortgage broker business from that location?** No. Once the mortgage broker branch office license has expired, you must not conduct any business under the act that requires a license until you renew your license.

~~((12))~~ (13) **If my mortgage broker main office license expires, may I still conduct my mortgage broker business from a branch office?** No. Once the mortgage broker main office license expires, you must not conduct any business under the act that requires a license from any location until you renew the main office license.

~~((13))~~ (14) **May I add a trade name (or "DBA") to my mortgage broker branch office license?** Yes. You may add a trade name, or "DBA" name, to the mortgage broker branch office license if you first apply to the department, in a form prescribed by the director, and receive department approval. The branch office trade name must at all times be identified as connected with the mortgage broker's license name as it appears on the mortgage broker license. When the department has approved the trade name, you must conduct business under that trade name in at least one of the two following ways:

(a) Use your license name together with the branch office trade name; or

(b) Use the branch office trade name and mortgage broker branch office license number together.

~~(c)~~ See WAC 208-660-180(10).

~~((14))~~ **(15) How must I identify my mortgage broker branch office(s)?** The branch office must be prominently identified as a branch or division of the licensed mortgage broker so as not to appear to be an independent enterprise.

~~((15))~~ **(16) Does my branch office have to be a physical location?** Yes. The physical location may be at a commercial or residential address but does not have to be in Washington. See WAC 208-660-420, Out-of-state mortgage brokers and loan originators.

~~((16))~~ **(17) Must I have a branch manager?** No. Although you may appoint one, the act does not require a branch manager. The licensee and designated broker are responsible for the business conducted at all locations.

~~((17))~~ **(18) Must I have a designated broker at each branch?** No. The licensed mortgage broker may have only one designated broker who is responsible for the mortgage broker business at all locations.

AMENDATORY SECTION (Amending WSR 06-23-137, filed 11/21/06, effective 1/1/07)

WAC 208-660-250 Designated brokers—General. (1) How do I become a designated broker?

(a) Be eighteen years or older.

(b) Have a high school diploma, an equivalent to a high school diploma, or three years experience in the industry in addition to the experience required in (e) of this subsection. The experience must meet the criteria in (e) of this subsection.

(c) You must pass the designated broker test. See WAC 208-660-260, Designated brokers—Testing.

~~((b))~~ (d) You must be appointed to the designated broker position by the licensed mortgage broker through an application and approval process with the department.

~~((e))~~ (e) You must have a minimum of two years~~(b)~~ experience lending or originating residential mortgage loans.

(i) The work experience must be in one or more of the following, within the last five years:

(A) As a mortgage broker or designated broker of a mortgage broker for a minimum of two years; or

(B) As a mortgage banker, responsible individual, or manager of a mortgage banking business; or

(C) As a loan originator with responsibility primarily for originating loans secured by a lien on residential real estate; or

(D) As a branch manager of a lender with responsibility primarily for loans secured by a lien on residential real estate; or

(E) As a manager or supervisor of mortgage loan originators; or

(F) As a mortgage processor, underwriter, or quality control professional; or

(G) As a regulator, examiner, investigator, compliance expert, or auditor, whose primary function is the review of

mortgage companies and their compliance processes, and the department determines your background is sufficient.

(ii) The work experience must be evidenced by a detailed work history and:

(A) W-2 Federal Income Tax Reporting Forms in the designated broker appointee's name; or

(B) 1099 Federal Income Tax Reporting Forms in the designated broker appointee's name; or

(C) Corporate tax returns signed by the designated broker appointee for a licensed or exempt residential mortgage company~~(-)~~; or

~~((d))~~ (e) In addition to supplying the application information, both you and the licensed mortgage broker must be in good standing with the department.

(f) Financial background. You are not eligible to become a designated broker if:

(i) You have one hundred thousand dollars or more of tax liens against you at the time of appointment by a licensed mortgage broker; or

(ii) Your financial background during the two years prior to the appointment application shows a history of unpaid debts.

(2) **May I work as the designated broker for more than one company?** Yes. You may be the designated broker for more than one licensee.

(3) **Must the designated broker also hold a loan originator's license?** A designated broker approved by the department will be given a loan originator license if they do not already have one. If the designated broker already has a loan originator license, that license will be added to the licensed mortgage broker's list of loan originators.

(4) **May I work as the designated broker for one licensee and a licensed loan originator for another licensee?** Yes. If you want to originate loans for a mortgage broker different from the mortgage broker for whom you are the designated broker, you must apply to the department for an additional loan originator license.

(5) **May a designated broker hire employees or independent contractors apart from the employees or independent contractors working for the mortgage broker licensee?** No. Only the mortgage broker licensee can have employees or independent contractors. This prohibition against a designated broker having employees or independent contractors includes clerical or administrative personnel whose work is related to the mortgage broker licensee's activities, and loan processors.

(6) **As a designated broker, what reporting requirements must I comply with?** See WAC 208-660-400, Reporting requirements.

Reviser's note: The typographical error in the above section occurred in the copy filed by the agency and appears in the Register pursuant to the requirements of RCW 34.08.040.

AMENDATORY SECTION (Amending WSR 06-23-137, filed 11/21/06, effective 1/1/07)

WAC 208-660-260 Designated brokers—Testing. (1) Must I pass a test prior to becoming a designated broker? Yes. You must take and pass a test prior to becoming a designated broker. See WAC 208-660-250(1) if you have never been a designated broker.

~~(2) ((After passing the designated broker test, will I have to take it again? You must retake the designated broker test if you have not been approved by the department and have not worked as a designated broker within the past five years.~~

~~(3) After passing the designated broker test, will I have to take the loan originator test to get a loan originator license? If you passed the designated broker test, and have worked as an approved designated broker in the past five years, you will be given a loan originator license without taking the loan originator test.) I am currently a designated broker, will I have to take the test again? You will only have to take the designated broker test again if you stop working as a designated broker for five years or longer.~~

(3) I am currently a designated broker that originates loans. Will I have to take the loan originator test and obtain a loan originator license? No. The department will provide you with a loan originator license automatically because you are a designated broker. Your loan originator license will renew in conjunction with the renewal of the mortgage broker main office you work with. If you stop acting as a designated broker, your loan originator license will become inactive. See WAC 208-660-350(12). You can reactivate the license by becoming affiliated with the same or another licensed mortgage broker as a loan originator. If you do not renew your license as provided in WAC 208-660-350(19), the license will expire.

(4) Where can I get information about the designated broker test? The department will publish the names and contact information of approved testing providers on the department web site.

(5) What topics may be covered in the designated broker test? The department will publish a list of designated broker test topics on the department's web site.

(6) How soon after failing the designated broker test may I take it again? After failing the test three consecutive times you must wait at least fourteen days before taking the test again.

AMENDATORY SECTION (Amending WSR 06-23-137, filed 11/21/06, effective 1/1/07)

WAC 208-660-300 Loan originators—General. (1) May I work as a loan originator for more than one mortgage broker? Yes.

(2) How do I obtain approval to work for more than one mortgage broker? Use the form prescribed by the director to get approval to add mortgage broker relationships to your license. The department will notify you if the relationship is not approved. The department will notify you and others associated with your license upon approval of your request. The application must include a fee for the additional relationship. See WAC 208-660-550.

(3) If I work as a loan originator for more than one mortgage broker, may I take an application from a borrower without identifying one specific mortgage broker? No. You may take an application for only one mortgage broker at a time in any one transaction. Prior to presenting yourself to a specific borrower as licensed to originate mortgage loans, you must state who you represent. You must clearly

identify the mortgage broker by name and address on the application, on all disclosures, authorization forms, and other material provided to the borrower. There must be no confusion by the borrower as to which mortgage broker you are representing at any given time.

~~((2)) (4) May a loan originator transfer loan files to a mortgage broker other than the mortgage broker the loan originator is associated with? No. Only the borrower may submit a written request to the licensed mortgage broker to transmit the borrower's selected information to another mortgage broker or lender. Loan files are the property of the mortgage broker named on the loan application and the mortgage broker must keep the original files and documents. The licensed mortgage broker must transmit the information within five business days after receiving the borrower's written request.~~

~~((3)) (5) May I act as a loan originator and a real estate agent in the same transaction or for the same borrower in different transactions? Yes, you may be both the loan originator and real estate broker or salesperson in the same transaction, or for the same borrower in different transactions. When either of these occur, you must provide to the borrower the following written disclosure:~~

"THIS IS TO GIVE YOU NOTICE THAT I OR ONE OF MY ASSOCIATES HAVE/HAS ACTED AS A REAL ESTATE BROKER OR SALESPERSON REPRESENTING THE BUYER/SELLER IN THE SALE OF THIS PROPERTY TO YOU. I AM ALSO A LOAN ORIGINATOR AND WOULD LIKE TO PROVIDE MORTGAGE SERVICES TO YOU IN CONNECTION WITH YOUR LOAN TO PURCHASE THE PROPERTY.

YOU ARE NOT REQUIRED TO USE ME AS A LOAN ORIGINATOR IN CONNECTION WITH THIS TRANSACTION. YOU ARE FREE TO COMPARISON SHOP WITH OTHER MORTGAGE BROKERS, AND LENDERS, AND TO SELECT ANY MORTGAGE BROKER, OR LENDER OF YOUR CHOOSING."

~~((4)) (6) As a loan originator, may I be paid directly by the borrower for my services? No. As a loan originator, you may not be paid any compensation or fees directly by the borrower.~~

~~((5)) (7) May a loan originator charge the borrower a fee, commission, or other compensation for preparing, negotiating, or brokering a loan for the borrower? No. A loan originator may not charge the borrower a fee, commission, or compensation of any kind in connection with the preparation, negotiation, and brokering of a residential mortgage loan.~~

(8) As a loan originator, may I be paid my portion of the mortgage broker fee directly from the loan closing?

(a) Yes. The settlement service provider may pay your portion of the mortgage broker fee directly to you, provided however, that the HUD-1 or equivalent settlement statement has the following information:

(i) Your name as it appears on your loan originator license;

(ii) Your loan originator license number; and

(iii) The amount to be paid to you by the settlement service provider.

(b) You must provide a copy of the HUD-1 or equivalent settlement statement to the licensed mortgage broker within twenty-four hours of the loan closing.

~~((6))~~ **(9) May a loan originator bring a lawsuit against a borrower for the collection of compensation?** No. Only licensed mortgage brokers, or exempt mortgage brokers, may bring collection actions against borrowers to collect compensation.

~~((7))~~ **(10) May I work as a licensed loan originator for a mortgage broker located out of the state?** Yes. You may originate loans for any mortgage broker you are affiliated with who is licensed under Washington law.

~~((8))~~ **(11) May a licensed loan originator hire employees or independent contractors to assist in the mortgage broker licensee's activities?** No. Only the mortgage broker licensee can have employees or independent contractors. This prohibition against loan originators hiring employees or independent contractors includes clerical or administrative personnel whose work is related to the mortgage broker licensee's activities, and loan processors.

~~((9))~~ **(12) Do loan processors have to be licensed as loan originators?** No. Loan processors are not required to have a loan originator license provided they work under the supervision and instruction of a licensed or exempt mortgage broker and do not hold themselves out as able to conduct the activities of a mortgage broker or loan originator. However, a loan processor may not work as an independent contractor unless licensed as a mortgage broker, mortgage broker branch office, or loan originator.

AMENDATORY SECTION (Amending WSR 07-13-079, filed 6/18/07, effective 7/19/07)

WAC 208-660-350 Loan originators—Licensing. (1) How do I apply for a loan originator license?

(a) **Be eighteen years or older.**

(b) **Have a high school diploma, an equivalent to a high school diploma, or three years experience in the industry. The experience must meet the criteria in WAC 208-660-250 (1)(e)(i) and (ii).**

(c) **Pass a licensing test.** You must take and pass a test that assesses your knowledge of the mortgage business and related regulations. See WAC 208-660-360, Loan originators—Testing.

~~((b))~~ (d) **Submit an application.** The application form will be prescribed by the director.

~~((c))~~ (e) **Prove your identity.** You must provide information to prove your identity.

~~((d))~~ (f) **Pay the application fee.** You must pay an application fee to cover the department's cost of processing and reviewing applications. See WAC 208-660-550, Department fees and costs.

(2) In addition to reviewing my application, what else will the department consider to determine if I qualify for a loan originator license?

(a) **General fitness and prior compliance actions.** The department will investigate your background to see that you demonstrate the experience, character, and general fitness

that commands the confidence of the community and creates a belief that you will conduct business honestly and fairly within the purposes of the act. This investigation may include a review of the number and severity of complaints filed against you, or any person you were responsible for, and a review of any investigation or enforcement activity taken against you, or any person you were responsible for, in this state, or any jurisdiction.

(b) **License suspensions or revocations.** You are not eligible for a loan originator license if you have been found to be in violation of the act or the rules, or have had a license issued under the act or any similar state statute suspended or revoked within five years of the filing of the present application.

(c) **Criminal history.** You are not eligible for a loan originator license if you have been convicted of a gross misdemeanor involving dishonesty or financial misconduct, or a felony, within seven years of the filing of the present application.

(3) May I originate residential mortgage loans in Washington without a loan originator license? Persons conducting the business of a loan originator without an active loan originator license must fall under one of the following categories of exemption from loan originator licensing:

(a) Persons conducting residential mortgage loan business exclusively for any exempt person under RCW 19.146.020 (1)(a)(i); or

(b) The exclusive agents conducting residential mortgage loan business for any exempt person under RCW 19.146.020 (1)(a)(ii); or

(c) The bona fide employees conducting residential mortgage loan business exclusively for any exempt person under RCW 19.146.020 (1)(b), (e), (g) or (h); or

(d) Those persons exempt under RCW 19.146.020 (1)(c) or (d).

(4) **What will happen if my loan originator license application is incomplete?** The department will reject and return the entire application package to you with a notice identifying the incomplete, missing, or inaccurate information. You must follow the department's directions to correct the problems. You may then resubmit the application package.

(5) **How do I withdraw my application for a loan originator license?** Provide the department with a written request to withdraw your application in a form prescribed by the director.

(6) **When will the department consider my loan originator license application to be abandoned?** If you do not respond within ten business days to the department's second request for information, your loan originator license application is considered abandoned. Failure to provide the requested information will not affect new applications filed after the abandonment. You may reapply by submitting a new application package.

(7) **What happens if the department denies my application for a loan originator license, and what are my rights if the license is denied?**

(a) The department will notify you if your application is denied. You will receive a refund of any unused portion of the application fee.

(b) If your license application lists any mortgage brokers, the department will also notify the mortgage brokers of the license denial.

(c) Under the Administrative Procedure Act, chapter 34.05 RCW, you have the right to request brief adjudicative proceeding. To request a hearing, notify the department, in writing, within twenty days from the date of the director's notice to you notifying you your license application has been denied.

(i) Brief Adjudicative Proceeding Adopted. The director adopts RCW 34.05.482 through 34.05.494 to administer brief adjudicative proceedings under WAC 208-660-350.

(ii) Presiding Officer. Brief adjudicative proceedings are conducted by a presiding officer designated by the director. The presiding officer must have department expertise in the subject matter, but must not have personally participated in the department's licensing application denial, or work in the department's division of consumer services, or such other division within the department delegated by the director to oversee implementation of the act and these rules.

(iii) Preliminary Records. The preliminary record for the brief adjudicative proceeding consists of the application and all associated documents including all documents relied upon by the department to deny the application and all correspondence between the applicant and the department regarding the application.

(iv) Notice of Hearing. The department will set the date, time, and place of the hearing, giving at least seven business days notice to the applicant.

(v) Written Documents. The applicant or their representatives may present written documentation. The presiding officer must designate the date for submission of written documents.

(vi) Oral Argument. The presiding officer may exercise discretion in allowing oral argument.

(vii) Witnesses. Witnesses will not be allowed to testify.

(viii) Agency Expertise Considered. The presiding officer may rely upon agency expertise in addition to the written record as a basis for a decision.

(ix) Initial Order. The presiding officer must make a written initial order within ten business days of the final date for submission of materials, or oral argument, if any. The initial order will become final twenty-one days after service on the applicant unless the applicant requests an administrative review or the department decides to review the matter.

(8) How will the department provide me with my loan originator license? The department may use any of the following methods to provide you with your loan originator license:

(a) A printed paper license sent to you by regular mail.

(b) A license sent to you electronically that you may print.

(c) A license verification available on the department's web site and accessible for viewing by the public.

(9) May I transfer, sell, trade, assign, loan, share, or give my loan originator license to someone else? No. A loan originator license authorizes only the individual named on the license to conduct the business at the location listed on the license.

(10) How do I change information on my loan originator license? You must file a license amendment application with the department, in a form prescribed by the ~~((department))~~ director within thirty days of the change occurring.

(11) If I am ~~((employed by a bank or other exempt entity))~~ not required to have a loan originator license to do my job, may I apply for and receive a loan originator license? Yes, you may apply for a license at any time. However, if you are not ~~((working for a licensed mortgage broker))~~ required to hold the license to conduct the activities of your job, your license will be considered inactive.

(12) What is an inactive loan originator's license? If an individual holds a loan originator license ~~((but is not working with a licensed mortgage broker))~~ when they are not required to under the act, they hold an inactive license. A person holding an inactive license may not hold themselves out as a licensed loan originator.

(13) When my loan originator's license is inactive, am I subject to the director's enforcement authority? Yes. Your license is granted under specific authority of the director and under certain situations you may be subject to the director's authority even if you are not doing any activity covered by the act.

(14) When my loan originator license is inactive, must I continue to pay annual fees, and complete continuing education for that year? Yes. You must comply with all the annual licensing requirements or you will be unable to renew your inactive loan originator license.

(15) May I originate loans from a web site when my license is inactive? You may not originate loans, or engage in any activity that requires a license under the act, while your license is inactive, except as allowed in subsection (3) of this section.

(16) How do I activate my loan originator license? When the department receives a notice, in a form prescribed by the department, from a licensed or exempt mortgage broker establishing a working relationship with you, your loan originator license will become active. The department will notify you and all mortgage brokers you are working with of the new working relationship established by the licensed mortgage broker.

(17) When may the department issue interim loan originator licenses? To prevent an undue delay, the director may issue interim loan originator licenses with a fixed expiration date. The license applicant must have substantially met the initial licensing requirements, as determined by the director, to receive an interim license.

For purposes of this section, undue delay includes the adjustment of license expiration or renewal dates to coincide with the implementation of systems designed to assist in uniformity and provide data repositories of licensing information.

One example of having substantially met the initial licensing requirements is: Submitting a complete application, paying all application fees, and the department having received and reviewed the results of the applicant's background check.

(18) When does my loan originator license expire? The loan originator license expires annually. The expiration

date is shown on the license. If the license is an interim license, it may expire in less than one year.

(19) How do I renew my loan originator license?

(a) Before the license expiration date you must:

- (i) Pay the annual assessment fee; and
- (ii) Meet the continuing education requirement.

(b) The renewed license is valid until it expires, or is surrendered, suspended or revoked.

(20) If I let my loan originator license expire, must I apply to get a new license? If you complete all the requirements for renewal within forty-five days of the expiration date you may renew an existing license. However, if you renew your license during this forty-five day period, in addition to paying the annual assessment on your license, you must pay an additional fifty percent of your annual assessment. See subsection (19) of this section for the license renewal requirements.

During this forty-five day period, your license is expired and you must not conduct any business under the act that requires a license.

Any renewal requirements received by the department must be evidenced by either a United States Postal Service postmark or department "date received" stamp within the forty-five days. If you fail to comply with the renewal request requirements within forty-five days, you must apply for a new license.

(21) If I let my loan originator license expire and then apply for a new loan originator license within one year of the expiration, must I comply with the continuing education requirements from the prior license period? Yes. Before the department will consider your new loan originator application complete, you must provide proof of satisfying the continuing education requirements from the prior license period.

(22) May I still originate loans if my loan originator license has expired? No. Once your license has expired you may no longer conduct the business of a loan originator as defined in the act and these rules.

~~((22))~~ **(23) What happens to the loan applications I originated before my loan originator license expired?** Existing loan applications must be processed by the licensed mortgage broker or another licensed loan originator working for the mortgage broker.

~~((23))~~ **(24) May I surrender my loan originator's license?** Yes. You may surrender your license before the license expires by notifying the department, in a form prescribed by the department.

Surrender of your loan originator license does not change your civil or criminal liability, or your liability for any administrative actions arising from acts or omission occurring before the license surrender.

~~((24))~~ **(25) Must I display my loan originator license where I work as a loan originator?** No. Neither you nor the mortgage broker company is required to display your loan originator license. However, evidence that you are licensed as a loan originator must be made available to anyone who requests it.

~~((25))~~ **(26) If I operate as a loan originator on the internet, must I display my license number on my web site?** Yes. You must display your license number, and the

license number and name as it appears on the license of the licensed mortgage broker you represent, on the web site.

~~((26))~~ **(27) Must I include my loan originator license number on any documents?** You must include your license number immediately following your name on solicitations, including business cards, advertisements, and residential mortgage loan applications.

~~((27))~~ **(28) When must I disclose my loan originator license number?** In the following situations you must disclose your loan originator license number and the name and license number of the mortgage broker you are associated with:

(a) When asked by any party to a loan transaction, including third party providers;

(b) When asked by any person you have solicited for business, even if the solicitation is not directly related to a mortgage transaction;

(c) When asked by any person who contacts you about a residential mortgage loan;

(d) When taking a residential mortgage loan application.

AMENDATORY SECTION (Amending WSR 06-23-137, filed 11/21/06, effective 1/1/07)

WAC 208-660-370 Loan originators—Continuing education. (1) **Where may I get information about continuing education for loan originators?** The department will publish a list of the approved professional organizations that provide continuing education, and approved individual courses on the department's web site. The professional organizations will have detailed information about the continuing education courses they offer.

(2) **How many clock hours of loan originator continuing education must I have each year?** The continuing education requirement will be in the form of approved courses. While the individual clock hours may vary, you must complete two courses, of no less than three hours each, annually. Alternatively, you may attend three mortgage broker commission meetings instead of completing one continuing education course.

(3) **As a loan originator, may I take the same approved course multiple times to meet my annual continuing education requirement?** No. You may not take the same approved course in the same or successive years to meet the annual requirements for continuing education.

(4) **If I teach an approved continuing education course may I use my course as credit toward my annual loan originator continuing education requirement?** Yes. As an instructor of an approved continuing education course, you may receive credit for your annually required loan originator continuing education courses from the course(s) you teach. You will receive credit at the rate of one course taught equaling two continuing education course credits.

(5) **How do I receive credit toward my continuing education requirement when I teach an approved continuing education course?** When you renew your license and seek to get credit for continuing education, submit to the department documentation evidencing approval of the continuing course you taught. The department will credit you

with completing two continuing education courses for each one approved course you teach.

(6) Is ethics a required continuing education course for loan originators? Yes. You must take an ethics continuing education course in your first year of holding a loan originator license. However, if you teach an approved continuing education course on ethics during your first year of holding a loan originator license, that will satisfy your ethics continuing education requirement for that year.

(7) If I take a loan originator continuing education course approved for multiple jurisdictions, will the department accept it as part of my continuing education requirement? If any state has continuing education requirements or standards at least as stringent as Washington's, their continuing education courses may be approved by the department as meeting the continuing education requirements under the act and these rules.

(8) If I accumulate more than the required loan originator continuing education course credits during a year, may I carry-over the excess credit to the next year? No. Continuing education credits only apply to the year in which they are taken.

(9) If I fail to complete the required continuing education, what happens to my loan originator license? When your license expires, the department will not renew it, and you cannot continue conducting any business under the act. See WAC 208-660-350(20) to renew your license within forty-five days of it expiring. See also, WAC 208-660-350(21).

(10) How will I know which courses and providers satisfy the continuing education requirement? The department will approve continuing education courses offered by course providers and will approve professional organizations offering courses. The providers, courses, and contact information will be listed on the department's web site.

(11) How do I provide the department with proof of the continuing education courses I have completed? You must provide the department with proof of your satisfactory completion of the course, in a form prescribed by the department.

(12) If the department reissues my license and the new expiration date does not coincide with the prior annual assessment period, will the department still give me credit for the continuing education courses I have taken in preparation for meeting the prior annual assessment date? Yes. The department will give you credit for the continuing education courses you have taken. You will not lose any credits due to the department's license expiration date adjustment.

AMENDATORY SECTION (Amending WSR 06-23-137, filed 11/21/06, effective 1/1/07)

WAC 208-660-400 Reporting requirements and notices to the department. (1) **As a licensed mortgage broker, what annual report must I provide to the department?** You must file a mortgage broker annual report, in a form prescribed by the director. The report must include:

(a) The total number of residential mortgage loans secured by Washington real estate that you originated and closed in the prior calendar year; and

(b) The total dollar volume (principal loan amounts) of the residential mortgage loans secured by Washington real estate that you originated and closed in the prior calendar year.

(2) When must I provide the mortgage broker annual report to the department? You must provide the completed report to the department by (~~May 1st~~) March 31st of each year (~~(beginning in 2007)~~). The first annual report for activity occurring in 2007, must be received by the department before or on March 31, 2008.

(3) What period of time must the mortgage broker annual report cover? The mortgage broker annual report must cover the prior calendar year from January 1st to December 31st.

(4) What action will the department take if I fail to file my mortgage broker annual report (~~by May 1st of each year~~)?

(a) When the report is over thirty days late, the department may begin an enforcement action against you.

(b) When your license is due for renewal, the department will not renew it if you have not filed your annual report.

(5) How do I notify the department when I want to change information on my mortgage broker or loan originator license? You must file a license amendment application with the department, in a form prescribed by the department within thirty days of the change occurring.

(6) As a designated broker or loan originator, must I notify the department if I change my residential address or telephone number? Yes. Whether your license is active or inactive, you must notify the department in a form prescribed by the department within thirty days of a change in your residential address and telephone number.

(7) As a designated broker or loan originator must I notify the department if I change my name? Yes. Whether your license is active or inactive, you must notify the department in a form prescribed by the department within thirty days of a name change.

(8) Must I notify the department of the physical address of my mortgage broker books and records? Yes. You must provide the physical address of your mortgage broker books and records in your initial license application. If the location of your books and records changes, you must provide the department, in a form prescribed by the department, with the new physical address within five business days of the change.

(9) Must I notify the department if my designated broker leaves, or is no longer my designated broker? Yes. You must notify the department, in a form prescribed by the department, within five business days of the loss of or change of status of your designated broker. See WAC 208-660-180(3).

(10) When and how do I change the information about my registered agent? Within five business days of the change, you must file a statement of change with the department, in a form prescribed by the department.

(11) If I am a registered agent under the act, must I notify the department if I resign? Yes. You must provide

the department with your statement of resignation letter at least thirty-one days prior to the intended effective date. You must also provide a copy of the resignation letter to the licensed mortgage broker. The department will terminate your appointment thirty-one days after receiving your resignation letter.

(12) Must I notify the department if I change the business structure of my company? When must I notify the department? If the change to your business adds officers, directors, or principal stockholders owning ten percent or more of the company, you must notify the department, in a form prescribed by the department, at least thirty days prior to the change. The department will consider the qualifications of the new people and notify you whether or not the proposed change is acceptable.

(13) What are my responsibilities when I sell my business?

(a) At least thirty days prior to the effective date of sale, you must notify the department of the pending sale, in a form prescribed by the director.

(b) You must surrender your license and complete the year's annual report.

(c) You must give written notice to borrowers, and to anyone who has applied for a loan, advising them of the change in ownership.

(d) You must give written notice to third party providers advising them of the change in ownership and bringing accounts payable current.

(e) You must maintain your records as required under the act and these rules.

(f) You must reconcile the trust account and return any funds to the borrowers or others to whom they belong, or transfer funds into a new trust account at the borrower's direction. If excess funds still remain and are unclaimed, follow the procedures provided by the department of revenue's unclaimed property division.

(14) Must I notify the department if I cease doing business in this state? You must notify the department within twenty days after you cease doing business in the state by filing a Mortgage Broker Closure Form and the annual report.

(15) Must I notify the department of changes to my trust account? Yes. You must notify the department within five business days of any change in the status, location, account number, or other particulars of your trust account, made by you or the federally insured financial institution where the trust account is maintained. A change in your trust account includes the addition of a trust account.

(16) Must I notify the department of changes to my Washington master business license? Yes. You must notify the department within five business days of any changes to your Washington master business license made by you or the agency issuing the license.

(17) Must I notify the department of changes to my standing with the Washington secretary of state? Yes. You must notify the department within five business days of any changes to your standing with the Washington secretary of state made by you or the secretary of state.

(18) What must I do if my licensed mortgage broker company files for bankruptcy?

(a) Chapter 7 bankruptcy. If you are a licensed mortgage broker that files for a Chapter 7 bankruptcy, you must:

(i) Notify the director and surrender your mortgage broker license within ten business days of filing the bankruptcy.

(ii) Provide the department with a mortgage broker annual report for the calendar year preceding the filing within ten business days of filing the bankruptcy.

(b) Chapter 11 bankruptcy. If your licensed mortgage broker company files for a Chapter 11 bankruptcy, you must notify the director within ten business days of filing the bankruptcy.

(c) Chapter 13 bankruptcy. If your licensed mortgage broker company files for a Chapter 13 bankruptcy, you must:

(i) Notify the director and surrender your mortgage broker license within ten business days of filing the bankruptcy.

(ii) Provide the department with a mortgage broker annual report for the calendar year preceding the filing within ten business days of filing the bankruptcy.

(19) If I am a designated broker and file for personal bankruptcy, what are my reporting responsibilities? A designated broker must notify the department in writing within ten business days of filing for bankruptcy protection.

(20) If I am a designated broker and file for personal bankruptcy, what action may the department take? The director may require the licensed mortgage broker to replace you with another designated broker.

(21) If I am a loan originator and file for personal bankruptcy, what are my reporting responsibilities? A licensed loan originator must notify the director in writing within ten business days of filing for bankruptcy protection.

(22) If I am a loan originator and file for personal bankruptcy, what action may the department take? Depending on the circumstances, the director may revoke or condition your license.

(23) When may I apply for a license after surrendering one due to my personal bankruptcy filing? If you surrendered your license, you may apply for a license at any time. However, the department may deny your license application for three years after the bankruptcy has been discharged provided that no new bankruptcies have occurred or are in progress.

(24) When may I apply for a license after the department has revoked my license due to my personal bankruptcy filing? The director will not issue a license to any person who has had their license revoked within five years of applying. While you may apply at any time, the application will be denied until the five years have elapsed. For this reason it is important for you to consider a surrender of your license rather than allowing it to be revoked.

(25) Who in the mortgage broker company must notify the department if they are charged with or convicted of a crime? Licensees, whether on active or inactive license status, must notify the department in writing within ten business days of being:

(a) Charged by indictment or information with any felony, or a gross misdemeanor involving dishonesty or financial misconduct in any jurisdiction.

(b) Convicted of any felony, or any gross misdemeanor involving dishonesty or financial misconduct in any jurisdiction.

(c) Convicted outside of Washington for any crime that if charged in Washington would constitute a felony, or gross misdemeanor for dishonesty or financial misconduct.

(26) Who in the mortgage broker company must notify the department if they are the subject of an administrative enforcement action? Licensees, whether holding active or inactive licenses, must notify the department in writing within ten business days of the occurrence if:

(a) Charged with any violations by an administrative authority in any jurisdiction; or

(b) The subject of any administrative action, including a license revocation action, in any jurisdiction.

AMENDATORY SECTION (Amending WSR 06-23-137, filed 11/21/06, effective 1/1/07)

WAC 208-660-430 Disclosure requirements. (1) What disclosures must I make to borrowers and when? Within three business days of receiving a borrower's loan application, or receiving money from a borrower for third-party provider services, you, as a mortgage broker or loan originator on behalf of a mortgage broker, must make all disclosures required by RCW 19.146.030 (1), (2), and (3). The disclosures must be in a form acceptable to the director.

(2) What is the disclosure required under RCW 19.146.030(1)? A full written disclosure containing an itemization and explanation of all fees and costs that the borrower is required to pay in connection with obtaining a residential mortgage loan, and specifying the fee or fees which inure to the benefit of the mortgage broker. A good faith estimate of a fee or cost must be provided if the exact amount of the fee or cost is not determinable. This subsection does not require disclosure of the distribution or breakdown of loan fees, discount, or points between the mortgage broker and any lender or investor.

The specific content of the disclosure required under RCW 19.146.030(1) is identified in RCW 19.146.030(2).

(3) What is the disclosure required under RCW 19.146.030(2)? Mortgage brokers must disclose the following content:

(a) The annual percentage rate, finance charge, amount financed, total amount of all payments, number of payments, amount of each payment, amount of points or prepaid interest and the conditions and terms under which any loan terms may change between the time of disclosure and closing of the loan; and if a variable rate, the circumstances under which the rate may increase, any limitation on the increase, the effect of an increase, and an example of the payment terms resulting from an increase.

Disclosure in compliance with the requirements of the Truth-in-Lending Act and Regulation Z, as now or hereafter amended, is considered compliance with the disclosure content requirements of this subsection; however, RCW 19.146.030(1) governs the delivery requirement of these disclosures;

(b) The itemized costs of any credit report, appraisal, title report, title insurance policy, mortgage insurance,

escrow fee, property tax, insurance, structural or pest inspection, and any other third-party provider's costs associated with the residential mortgage loan. Disclosure through good faith estimates of settlement services and special information booklets in compliance with the requirements of RESPA and Regulation X, as now or hereafter amended, is considered compliance with the disclosure content requirements of this subsection; however, RCW 19.146.030(1) governs the delivery requirement of these disclosures;

(c) If applicable, the cost, terms, duration, and conditions of a lock-in agreement and whether a lock-in agreement has been entered, and whether the lock-in agreement is guaranteed by the mortgage broker or lender, and if a lock-in agreement has not been entered, disclosure in a form acceptable to the director that the disclosed interest rate and terms are subject to change;

(d) A statement that if the borrower is unable to obtain a loan for any reason, the mortgage broker must, within five days of a written request by the borrower, give copies of any appraisal, title report, or credit report paid for by the borrower, to the borrower, and transmit the appraisal, title report, or credit report to any other mortgage broker or lender to whom the borrower directs the documents to be sent;

(e) Whether and under what conditions any lock-in fees are refundable to the borrower; and

(f) A statement providing that moneys paid by the borrower to the mortgage broker for third-party provider services are held in a trust account and any moneys remaining after payment to third-party providers will be refunded.

(4) How do I disclose my mortgage broker fees on the good faith estimate and settlement statement? You must disclose or direct the disclosure of your fees on lines 808 through 811 of the good faith estimate and HUD-1/1A settlement statement or similar document.

(5) How do I disclose my yield spread premium (YSP) from the lender? The YSP must be disclosed in the 800 series of lines on the GFE and HUD-1 or equivalent settlement statement. On both the GFE and HUD-1 or equivalent settlement statement, the YSP must be listed using the words "yield spread premium" and expressed as a dollar amount or dollar amount range.

(6) Are there additional disclosure requirements related to interest rate lock-ins? Yes. Pursuant to RCW 19.146.030(3), if subsequent to the written disclosure being provided under this section, a mortgage broker or loan originator enters into a lock-in agreement with a borrower or represents to the borrower that the borrower has entered into a lock-in agreement, then ~~((no less than three business days thereafter including Saturdays,))~~ within three business days the mortgage broker or loan originator must deliver or send by first-class mail to the borrower a written confirmation of the terms of the lock-in agreement, which must include a copy of the disclosure made under subsection (3)(c) of this section.

~~((6))~~ **(7) What must I disclose to the borrower if they do not choose to enter into a lock-in agreement?** If a lock-in agreement has not been entered into, you must disclose to the borrower that the disclosed interest rate and terms are subject to change.

~~((7))~~ **(8) Will a lock-in agreement always guarantee the interest rate and terms?** No. A lock-in agreement may or may not be guaranteed by the mortgage broker or lender. The lock-in agreement must clearly state whether the lock-in agreement is guaranteed by the mortgage broker or lender.

~~((8))~~ **(9) Must a mortgage broker enter into a lock-in agreement with a borrower?** No. The statute does not require a mortgage broker to enter into a lock-in agreement with a borrower.

~~((9))~~ **(10) Are there any model forms that suffice for the disclosure content under RCW 19.146.030(2)?** Yes. The following model forms are acceptable forms of disclosure:

(a) For RCW 19.146.030 (2)(a), mortgage brokers are encouraged to use the federal truth-in-lending disclosure form for mortgage loan transactions provided under the Truth-in-Lending Act and Regulation Z, as now or hereafter amended. However, the federal truth-in-lending disclosure only suffices for the content of disclosures under RCW 19.146.030 (2)(a). The delivery of disclosures is governed by RCW 19.146.030(1).

(b) For RCW 19.146.030 (2)(b), mortgage brokers are encouraged to use the federal good faith estimate disclosure form provided under the Real Estate Settlement Procedures Act and Regulation X, as now or hereafter amended. However, the federal good faith estimate disclosure only suffices for the content of disclosures under RCW 19.146.030 (2)(b). The delivery of disclosures is governed by RCW 19.146.030 (1).

(c) For RCW 19.146.030 (2)(c), (d), (e), (f) and (3), the department encourages mortgage brokers to use the department published model disclosure forms that can be found on the department's web site.

~~((10))~~ **(11) May my mortgage broker fees increase following the disclosures required under RCW 19.146.030(1)?** Pursuant to RCW 19.146.030(4), a mortgage broker must not charge any fee that inures to the benefit of the mortgage broker if it exceeds the fee disclosed on the initial written good faith estimate disclosure required in RCW 19.146.030 (1) and (2)(b), unless:

(a) The need to charge the fee was not reasonably foreseeable at the time the written disclosure was provided; and

(b) The mortgage broker has provided to the borrower, no less than three business days prior to the signing of the loan closing documents, a clear written explanation of the fee and the reason for charging a fee exceeding that which was previously disclosed.

~~((11))~~ **(12) Are there any situations in which fees that benefit the mortgage broker can increase without additional disclosure?** Yes, there are two possible situations where an increase in the fees benefiting the mortgage broker may increase without the requirement to provide additional disclosures. These situations are:

(a) The additional disclosure is not required if the borrower's closing costs, excluding prepaid escrowed costs of ownership, on the final settlement statement do not exceed the total closing costs, excluding prepaid escrowed costs of ownership, in the most recent good faith estimate provided to the borrower. For purposes of this section "prepaid escrowed costs of ownership" mean any amounts prepaid by the bor-

rower for the payment of taxes, property insurance, interim interest, and similar items in regard to the property used as security for the loan; or

(b) The fee or set of fees that benefit the mortgage broker are disclosed as a percentage of the loan amount and the increase in fees results from an increase in the loan amount, provided that:

(i) The increase in loan amount is requested by the borrower; and

(ii) The fee or set of fees that are calculated as a percentage of the loan amount have been disclosed on the initial written disclosure as both a percentage of the loan amount and as a dollar amount based upon the assumed loan amount used in the initial written disclosure; and

(iii) The total aggregate increase in the fee or set of fees that benefit the mortgage broker as a result of the increase in loan amount is less than seven hundred fifty dollars.

~~((12))~~ **(13) What action may the department take if I disclose my mortgage broker fees on the good faith estimate and HUD-1/1A statement on lines other than 808 through 811?** If you fail to disclose your mortgage broker fees as required, the department may request, direct, or order you to refund those fees to the borrower. For example, if you disclose your mortgage broker fees as loan origination fees or discount points, the department may find that this is a deceptive practice and take action against you as indicated.

~~((13))~~ **(14) May the department take action against a mortgage broker when mortgage broker fees are disclosed incorrectly on the HUD-1/1A and the incorrect disclosure was made by an independent escrow agent, title company, or lender?** If the mortgage broker can show the department that they disclosed their fees correctly on the good faith estimate, and have instructed the independent escrow agent, title company, or lender to disclose the fees correctly on the HUD-1/1A, and the independent escrow agent, title company, or lender has not followed the instructions, the department may not take action against the mortgage broker.

~~((14))~~ **(15) What action may the department take if I fail to provide additional disclosures as required under RCW 19.146.030(4)?** Generally, the department ~~((will))~~ may request, direct, or order you to ~~((pay restitution to borrowers that have paid))~~ refund fees ~~((to you in excess of the amounts initially disclosed))~~.

~~((15))~~ **(16) How will the department determine whether ~~((borrowers have paid fees to me in excess of the amounts initially disclosed for which the department might))~~ to request, direct or order ((restitution)) me to refund fees to the borrowers?** Generally, the department will make its determination by answering the following questions:

(a) Has an initial good faith estimate disclosure of costs been provided to the borrower in accordance with RCW 19.146.030 (1) and (2)(b)?

(b) Were any subsequent good faith estimate disclosures of costs provided to the borrower no less than three business days prior to the signing of the loan closing documents? Additionally, was the subsequent disclosure accompanied by a clear written explanation of the change?

(c) How were the costs disclosed in each good faith estimate (e.g., dollar amount, percentage, or both)?

(d) Did the total costs, excluding prepaid escrowed costs of ownership, on the final settlement statement exceed the total closing costs, excluding prepaid escrowed costs of ownership, in the most recent good faith estimate provided to the borrower no less than three business days prior to the signing of the loan closing documents?

(e) If the costs at closing did exceed the most recent disclosure of costs was the need to charge the fee reasonably foreseeable at the time the written disclosure was provided?

(f) If the costs at closing did exceed the most recent disclosure of costs did the mortgage broker provide a clear written explanation of the fee and the reason for charging a fee exceeding that which was previously disclosed, no less than three business days prior to the signing of the loan closing documents?

~~((16))~~ **(17) If I failed to provide the initial good faith estimate or TILA disclosure under RCW 19.146.030 (1) and (2)(a) and (b) what action may the department take?** If you have not provided the initial good faith estimate or TILA disclosure as required, including both delivery and content requirements, the department may request, direct or order you to ~~((pay restitution))~~ refund to the borrower ~~((in the amount of all))~~ fees that inured to your benefit.

~~((17))~~ **(18) If I received trust funds from a borrower, but failed to provide the disclosures as required in RCW 19.146.030 (1) and (2), what action may the department take?** If you did not provide the disclosures as required, including both delivery and content requirements, the department may request, direct, or order you to refund to the borrower any trust funds they have paid regardless of whether you have already expended those trust funds on third-party providers.

~~((18))~~ **(19) Under what circumstances must I redisclose the initial disclosures required under the act?** Generally, any loan terms or conditions that change must be redisclosed no less than three business days, prior to closing, to the borrower. Some examples are:

- (a) Adjustable rate loan terms, including index, margin, and any changes to the fixed period.
- (b) The initial fixed period.
- (c) Any balloon payment requirements.
- (d) Interest only options and any changes to the options.
- (e) Lien position of the loan.
- (f) Terms and the number of months or years for amortization purposes.

(g) Prepayment penalty terms and conditions.

(h) Any other term or condition that may be specific to a certain loan product.

~~((19))~~ **(20) Must I provide the written disclosures required under RCW 19.146.030 if all I do is obtain a credit report on a consumer who has identified a specific property for a purchase and sales agreement or contract, or a refinance loan?** Yes. At that point, you have collected enough information on behalf of the consumer for you to anticipate a credit decision under RESPA's Regulation X, 24 ~~((CFR))~~ C.F.R. Sections 3500 et seq. and you must provide the consumer with all required disclosures. See the definition of "application" in these rules.

~~((20))~~ **(21) If a loan application is canceled within three days of application must I provide the disclosures required under RCW 19.146.030?** If you have not used any borrower trust funds and those funds have been returned to the borrower in conformance with these rules, the disclosures pursuant to RCW 19.146.030 are not required.

~~((21))~~ **(22) Is a mortgage broker that table funds a loan exempt from disclosures?** No. A mortgage broker must provide all disclosures required by the act, and disclose all fees as required by Regulation X, regardless of the funding mechanism used in the transaction.

~~((22))~~ **(23) What must I disclose to a potential borrower when I advertise my business or services to them using information about their current loan?** You must disclose the source from which you obtained the information about the borrower's current loan when the information was not obtained by soliciting, making a residential loan, or assisting that potential borrower in obtaining or applying to obtain a residential mortgage loan. If the information was provided by a company that searched public records and provided you the information, the "source" is the company that provided the records, not "public records."

~~((23))~~ **(24) What must I provide to the borrower if I am unable to complete a loan for them and they have paid for services from third-party providers?** If you are unable to complete a loan for the borrower for any reason, and if the borrower has paid you for third-party provider services, and the borrower makes a written request to you, you must provide the borrower with copies of the product from any third-party provider, including, but not limited to, an appraisal, title report, or credit report. You must provide the copies within five business days of the borrower's request.

The borrower may also request that you provide the originals of the documents to another mortgage broker or lender of the borrower's choice. By furnishing the originals to another mortgage broker or lender, you are conveying the right to use the documents to the other broker or lender. You must, upon request by the other broker or lender, provide written evidence of the conveyance. You must provide the originals to the mortgage broker or lender within five business days of the borrower's request.

AMENDATORY SECTION (Amending WSR 06-23-137, filed 11/21/06, effective 1/1/07)

WAC 208-660-440 Advertising. (1) **Am I responsible for ensuring that my advertising material is accurate, reliable, and in compliance with the act?** Yes. Each mortgage broker is responsible for ensuring the accuracy and reliability of the advertising material.

(2) **A licensee is prohibited from advertising with envelopes or stationery that contain an official-looking emblem designed to resemble a government mailing or that suggest an affiliation that does not exist. What are some examples of emblems or government-like names, language, or nonexistent affiliations that will violate the state and federal advertising laws?** Some examples include, but are not limited to:

(a) An official-looking emblem such as an eagle, the Statue of Liberty, or a crest or seal that resembles one used by any state or federal government agency.

(b) Envelopes designed to resemble official government mailings, such as IRS or U.S. Treasury envelopes, or other government mailers.

(c) Warnings or notices citing government codes or form numbers not required by the U.S. Postmaster to be shown on the mailing.

(d) The use of the term "official business," or similar language implying official or government business, without also including the name of the sender.

(e) Any suggestion or representation that the solicitor is affiliated with any agency, bank, or other entity that it does not actually represent.

(3) When I am advertising interest rates, the act requires me to conspicuously disclose the annual percentage rate (APR) implied by the rate of interest. What does it mean to "conspicuously" disclose the APR? The ((type size)) required disclosures in your advertisements must be reasonably understandable. Consumers must be able to read or hear, and understand the information. Many factors, including the size, duration, and location of the required disclosures, and the background or other information in the advertisement, can affect whether the information is clear and conspicuous. The disclosure of the APR must be ((the same size or larger than)) as prominent or more prominent than any other rates ((stated)) disclosed in the advertisement, regardless of the form of the advertisement.

(4) The act prohibits me from advertising an interest rate unless that rate is actually available at the time of the advertisement. How may I establish that an advertised interest rate was "actually available" at the time it was advertised? Whenever a specific interest rate is advertised, the mortgage broker must retain a copy of the lender's "rate sheet," or other supporting rate information, and the APR calculation for the advertised interest rate.

(5) Must I quote the annual percentage rate when discussing rates with a borrower? Yes. You must quote the annual percentage rate and other terms of the loan if you give an oral quote of an interest rate to the borrower. TILA's Regulation Z, 12 ((CFR)) C.F.R., part 226.26 provides guidance for using the annual percentage rate in oral disclosures.

(6) May a mortgage broker or loan originator advertise rates or fees as the "lowest" or "best"? No. Rates described as "lowest," "best," or other similar words cannot be proven to be actually available at the time they are advertised. Therefore, they are a false or deceptive statement or representation prohibited by RCW 19.146.0201(7).

(7) When I advertise, or present a business card to a potential borrower, must I make the disclosures required under the act and these rules? No. You are not required to make disclosures until you accept a residential mortgage loan application, or until you assist a borrower in preparing an application.

(8) May I solicit using advertising that suggests or represents that I am affiliated with a state or federal agency, municipality, federally insured financial institution, trust company, building and loan association, when I am not; or that I am an entity other than who I am? No.

It is an unfair and deceptive act or practice and a violation of the act for you to suggest or represent that you are affiliated with a state or federal agency, municipality, federally insured financial institution, trust company, building and loan association, or other entity you do not actually represent; or to suggest or represent that you are any entity other than who you are.

(9) If I advertise using a borrower's current loan information, what must I disclose about that information? When an advertisement includes information about a borrower's current loan that you did not obtain from a solicitation, application, or loan, you must provide the borrower with:

(a) The name of the source of the information;

(b) A statement that you are not affiliated with the borrower's lender; and

(c) The information disclosed in (a) and (b) of this subsection must be in the same size type font as the rest of the information in the advertisement.

AMENDATORY SECTION (Amending WSR 06-23-137, filed 11/21/06, effective 1/1/07)

WAC 208-660-500 Prohibited practices. (1) What may I request of an appraiser? You may request an area or market survey. While there are no strict definitions of these terms, generally they refer to general information regarding a region, area, or plat. The information usually includes the high, low and average sales price, numbers of properties available for sale or that have been sold within a set period, marketing times, days on market, absorption rate or the mixture of different property types in the specified area, among other possible components. An area survey does not contain sufficient information or is not so defining as to allow an appraiser or reader to determine the value of a specified property or property type.

(2) How may I discuss property values with an appraiser, prior to the appraisal, without the discussion constituting improperly influencing the appraiser? You may inform the appraiser of your opinion of value, the borrower's opinion of value, or the list or sales price of the property. You are prohibited from telling the appraiser the value you need or that is required for your loan to be successful.

(3) What business practices are prohibited? The following business practices are prohibited:

(a) Directly or indirectly employing any scheme, device, or artifice to defraud or mislead borrowers or lenders or to defraud any person.

(b) Engaging in any unfair or deceptive practice toward any person.

(c) Obtaining property by fraud or misrepresentation.

(d) Soliciting or entering into a contract with a borrower that provides in substance that the mortgage broker may earn a fee or commission through the mortgage broker's "best efforts" to obtain a loan even though no loan is actually obtained for the borrower.

(e) Charging discount points on a loan which does not result in a reduction of the interest rate. Some examples of discount point misrepresentations are:

(i) A mortgage broker or lender charging discount points on the good faith estimate or settlement statement payable to the mortgage broker or any party that is not the actual lender on the resident mortgage loan.

(ii) Charging loan fees or mortgage broker fees that are represented to the borrower as discount points when such fees do not actually reduce the rate on the loan, or reflecting loan origination fees or mortgage broker fees as discount points.

(iii) Charging discount points that are not mathematically determinable as the same direct reduction of the rate available to any two borrowers with the same program and underwriting characteristics on the same date of disclosure.

(f) Failing to clearly and conspicuously disclose (~~to a borrower~~) whether (~~the~~) a payment advertised or offered for a residential mortgage loan includes amounts for taxes, insurance, or other products sold to the borrower. This prohibition includes the practice of misrepresenting, either orally (~~or~~), in writing, or in any advertising materials, a loan payment that includes only principal and interest as a loan payment that includes principal, interest, tax, and insurance.

(g) Failing to provide the exact pay-off amount of a loan you own or service as of a certain date five or fewer business days after being requested in writing to do so by a borrower of record or their authorized representative.

(h) Failing to record a borrower's payment, on a loan you own or service, as received on the day it is delivered to any of the licensee's locations during its regular working hours.

(i) Negligently making any false statement or willfully making any omission of material fact in connection with any application or any information filed by a licensee in connection with any application, examination or investigation conducted by the department.

(j) Purchasing insurance on an asset secured by a loan without first attempting to contact the borrower by mailing one or more notices to the last known address of the borrower in order to verify that the asset is not otherwise insured.

(k) Willfully filing a lien on property without a legal basis to do so.

(l) Coercing, intimidating, or threatening borrowers in any way with the intent of forcing them to complete a loan transaction.

(m) Failing to reconvey title to collateral, if any, within thirty days when the loan is paid in full unless conditions exist that make compliance unreasonable.

(n) Failing to make disclosures to loan applicants and noninstitutional investors as required by RCW 19.146.030 and any other applicable state or federal law.

(o) Making, in any manner, any false or deceptive statement or representation with regard to the rates, points, or other financing terms or conditions for a residential mortgage loan (~~or~~).

(p) Engage in bait and switch advertising (~~or other deceptive advertising practices~~).

Bait and switch means a deceptive practice of soliciting or promising a loan at favorable terms, but later "switching" or providing a loan at less favorable terms. While bait and switch will be determined by the facts of a case, the following examples, alone or in combination, may exhibit a bait and switch practice:

(i) A deceptive change of loan program from fixed to variable rate.

(ii) A deceptive increase in interest rate.

(iii) The misrepresentation of discount points. This may include discount points that have a different rate buydown effect than promised, or origination fees that a borrower has been led to believe are discount points affecting the rate.

(iv) A deceptive increase in fees or other costs.

(v) A deceptive disclosure of monthly payment amount. This practice may involve soliciting a loan with payments that do not include monthly amounts for taxes and insurance or other reserved items, while leading the borrower to believe that such amounts are included.

(vi) Additional undisclosed terms such as prepayment penalties or balloon payments, or deceiving borrowers about the effect of disclosed terms.

(vii) Additional layers of financing not previously disclosed that serve to increase the overall cost to the borrower. This practice may involve the surprise combination of first and second mortgages to achieve the originally promised loan amount.

(viii) Leading borrowers to believe that subsequent events will be possible or practical when in fact it is known that the events will not be possible or practical.

(ix) Advertising or offering rates, programs, or terms that are not actually available at the time. See WAC 208-660-440(4).

(q) Engage in unfair or deceptive advertising practices. Unfair advertising may include advertising that offends public policy, or causes substantial injury to consumers or to competition in the marketplace.

~~((r))~~ (r) Negligently making any false statement or knowingly and willfully make any omission of material fact in connection with any reports filed by a mortgage broker or in connection with any investigation conducted by the department.

~~((s))~~ (s) Making any payment, directly or indirectly, to any appraiser of a property, for the purposes of influencing the independent judgment of the appraiser with respect to the value of the property.

~~((t))~~ (t) Advertising a rate of interest without clearly and conspicuously disclosing the annual percentage rate implied by the rate of interest.

~~((u))~~ (u) Failing to comply with the federal statutes and regulations in RCW 19.146.0201(11).

~~((v))~~ (v) Failing to pay third-party providers within the applicable (~~time lines~~) timelines.

~~((w))~~ (w) Collecting or charging, or attempting to collect or charge, or use or propose any agreement purporting to collect or charge any fees prohibited by the act.

~~((x))~~ (x) Acting as a loan originator and real estate broker or salesperson, or acting as a loan originator in a manner that violates RCW 19.146.0201(14).

~~((y))~~ (y) Failing to comply with any provision of RCW 19.146.030 through 19.146.080 or any rule adopted under those sections.

(4) What federal guidance has the director adopted for use by the department in determining if a violation under subsection (3)(b) of this section has occurred? The director has adopted the following documents:

(a) The Conference of State Bank Supervisors and American Association of Residential Mortgage Regulators "Guidance on Nontraditional Mortgage Product Risks" (released November 14, 2006); and

(b) The Conference of State Bank Supervisors, American Association of Residential Mortgage Regulators, and National Association of Consumer Credit Administrators "Statement on Subprime Mortgage Lending," effective July 10, 2007 (published in the Federal Register at Vol. 72, No. 131).

(5) May I charge a loan origination fee or discount points when I originate but do not make a loan? No. You may not charge a loan origination fee or discount points as described in Regulation X, Part 3500, Appendix A.

~~((5))~~ **(6) What mortgage broker fees may I charge?** You may charge a mortgage broker fee that was agreed upon between you and the borrower as stated on a good faith estimate disclosure form or similar document provided that such fee is disclosed in compliance with the act and these rules.

~~((6))~~ **(7) How do I disclose my mortgage broker fees on the good faith estimate and settlement statement?** You must disclose or direct the disclosure of your fees on lines 808 through 811 of the good faith estimate and HUD-1/IA Settlement Statement or similar document.

~~((7))~~ **(8) May I charge the borrower a fee that exceeds the fee I initially disclosed to the borrower?** Pursuant to RCW 19.146.030(4), you may not charge any fee that benefits you if it exceeds the fee you initially disclosed unless:

(a) The need to charge the fee was not reasonably foreseeable at the time the initial disclosure was provided; and

(b) You have provided to the borrower, no less than three business days prior to the signing of the loan closing documents, a clear written explanation of the fee and the reason for charging a fee exceeding that which was previously disclosed. See WAC 208-660-430 for specific details, disclosures, and exceptions implementing RCW 19.146.030(4).

AMENDATORY SECTION (Amending WSR 06-23-137, filed 11/21/06, effective 1/1/07)

WAC 208-660-530 Director and department powers—Enforcement authority. (1) **What is a directive?** A directive is a formal request for information from the director. A directive may request the recipient to appear in person to testify or present specific documents or items. A directive may be entitled "directive" or "subpoena."

(2) **What is an administrative enforcement action?** An administrative enforcement action is a formal action, generally initiated by a statement of charges filed by the department against persons who allegedly violated the act. Enforcement actions seek various sanctions, including, but not limited to, license revocation or suspension, business practice prohibition, or fines; and may include ordering restitution for ~~((consumers))~~ borrowers, recovery of the department's investigation costs, or all of the above.

(3) **What other types of enforcement action may the department pursue against me or my license?** The department may pursue criminal or civil referrals to the attorney

general, prosecuting attorneys, or federal authorities, and may initiate civil actions in superior court.

(4) What does it mean to be found in violation of the act and rules? For the purposes of evaluating the licensing qualifications of an applicant, any of its principals, or the designated broker, "found in violation of the act and rules" means at least one of the following orders has been issued:

(a) A superior court order stating the applicant, any of its principals, or the designated broker violated any of the provisions of the act or rules; or

(b) A final administrative order after the completion of an administrative hearing and the filing of an initial decision of an administrative law judge stating the applicant, any of its principals, or the designated broker violated any of the provisions of the act or rules; or

(c) An administrative order stating the applicant, any of its principals, or the designated broker violated any of the provisions of the act or rules.

The order containing the finding described above must not have been entered within five years of the filing of the present application. However, if the violation resulted in a conviction of a gross misdemeanor involving dishonesty or financial misconduct, or a felony, the finding must not have been entered within seven years of the filing of the present application.

(5) May the department sanction me for committing violations in another jurisdiction? The department may seek sanctions against you for committing a violation in another jurisdiction if the violation could be a basis for the department to seek sanctions under the act or rules. Possible sanctions include those found in RCW 19.146.220.

(6) May I be subject to a daily fine for violating the act? Yes. Each licensed mortgage broker and each of its principals, officers, designated brokers, loan originators, employees, independent contractors, and agents must comply with the applicable provisions of the act. Each violation of any applicable provision of the act, or of any order, directive, or requirement of the director may, at the discretion of the director, subject the violator to a fine of up to one hundred dollars for each offense. Each day's continuance of the violation is a separate and distinct offense. In addition, the director may exercise discretion and by order assess other penalties for a violation of the act.

(7) Under what circumstances will the department hold a designated broker, principal, or owner who has supervisory authority responsible for the actions of others that violate the act? A designated broker, principal, or owner with supervisory authority is responsible for any conduct violating the act by a licensee, employee, or independent contractor if they:

(a) Directed or instructed the conduct that was in violation of the act, or had knowledge of the specific conduct, and approved or allowed the conduct; or

(b) Knew, or by the exercise of reasonable care and inquiry should have known, of the conduct in time to prevent it, or minimize the consequences, and did not.

(8) When conduct violating the act has occurred, what may the department consider when assessing the responsibility of the designated broker, principal, and owner with supervisory authority? The department may

consider the following in an effort to determine who is responsible when a violation of the act has occurred. The following list is not limiting or exhaustive of the factors the department may consider:

(a) The adequacy of any background and experience investigation conducted prior to hiring or contracting with any person;

(b) The adoption of policies and procedures for:

(i) Supervision and training;

(ii) Regularly reviewing work performed;

(iii) Training in the requirements of the act and rules;

(iv) Monitoring continuing education requirements and compliance under the act;

(v) Acting on reports of alleged misconduct;

(c) Adopting a system of review for implementation and compliance with the policies and procedures;

(d) Providing copies of the act and rules; and

(e) The frequency and completeness of review conducted on work performed by any person subject to the act.

The items listed in (a) through (e) of this subsection must be in writing, or compliance with them must be documented in writing, and all documents must be retained as part of the mortgage broker business records. See WAC 208-660-450.

(9) Do I have the right to have an attorney represent me at an adjudicative hearing and in any superior court proceeding? Yes. You may have an attorney represent you at your own expense, or you may represent yourself.

(10) Are there any criminal penalties related to violations of the act? Yes. Violations of RCW 19.146.050 are class C felonies with a maximum penalty of five years in prison or a fine of ten thousand dollars, or both. Violations of RCW 19.146.235(9) are class B felonies with a maximum penalty of ten years in prison or a fine of twenty thousand dollars, or both. All other violations of the act are misdemeanors with a maximum penalty of ninety days in jail or a fine of not more than one thousand dollars, or both.

(11) Under the act, is it a crime for any person subject to examination or investigation to knowingly withhold, abstract, remove, mutilate, destroy, or secrete any books, records, computer records, or other information? Yes. Knowingly withholding, abstracting, removing, mutilating, destroying, or secreting books, records, computer records, or other information is a class B felony punishable under RCW 9A.20.021 (1)(b).

(12) Is a mortgage broker responsible for the payment of third-party providers even if the borrower has agreed to pay the fee? Yes. If a mortgage broker or loan originator orders the third-party provider service, then the mortgage broker is responsible for paying for the service. However, the mortgage broker or loan originator is not responsible for paying the fee if the third-party provider agrees in writing to accept the fee from the borrower.

(13) When must third-party providers be paid? Third-party providers must be paid no later than thirty days after the related loan closing documents are filed, or within ninety days of the service, whichever is sooner, unless:

(a) The third-party provider agrees in writing to a different payment arrangement; or

(b) The third-party provider has been notified in writing that a bona fide dispute exists regarding the performance or quality of the third-party provider service.

(14) What is a "bona fide" dispute between a mortgage broker and third-party provider? A dispute related to the performance or quality of the third-party provider service that has been reported in writing to the third-party provider. The report must specify the disputed areas of performance or quality.

(15) When must a dispute regarding the performance or quality of a third-party provider be reported? The report of a dispute regarding the performance or quality of the third-party provider service must be made in writing and provided to the third-party provider before the payment for the services becomes due; that is, no later than thirty days after the related loan closing documents are filed, or within ninety days of the service, whichever is sooner.

(16) What is a temporary cease and desist order issued by the department? A temporary cease and desist order is an administrative enforcement action by the director, or designee, ordering a mortgage broker or loan originator to stop conducting business, or to stop doing some specific act.

(17) When does the department use temporary cease and desist orders? A temporary cease and desist order may be used when the department determines that a mortgage broker or loan originator is violating the act in a manner that is likely to cause substantial injury to the public.

(18) What happens to my mortgage broker or loan originator license if the department of social and health services (DSHS) certifies me as out of compliance with a support order under RCW 74.20A.320?

(a) The director will immediately suspend your license without the opportunity for a hearing if the department receives notice from DSHS that you are out of compliance with their support order regulations.

(b) The director will send you a document entitled "Notice of Suspension for Noncompliance with Child Support Order." Your license is suspended from the date of the notice. The suspension of your license remains in effect until the director is notified by DSHS of your compliance with their order. You must not perform any services under the act that require licensing while your license is suspended.

(19) If the director suspends my license after notice from DSHS that I am not in compliance with a support order, may my license be reinstated?

(a) The director will reinstate your license when the department has received written notice from DSHS of your compliance, and verified that you meet all licensing requirements under the act.

(b) The department will send you a notice entitled "Notice of Cancellation of Suspension for Noncompliance with Child Support Order." Your license is reinstated from the date of the notice.

(20) Who may I contact if I have questions about how DSHS determines I am out of compliance with a support order? Contact DSHS if you have questions about a DSHS certification of your noncompliance with a support order. Reference their case number when you contact them.

AMENDATORY SECTION (Amending WSR 06-23-137, filed 11/21/06, effective 1/1/07)

WAC 208-660-550 Department fees and costs. (1)

The department intends to increase its fees and costs each year for several bienniums. The department intends to initiate rule making each biennium for this purpose. This rule provides for an automatic annual increase in the rate of fees and costs each fiscal year during the 2007-2009 biennium.

(a) On July 1, 2007, and July 1, 2008, these fees and costs, as increased in the prior fiscal year, will increase by a percentage rate equal to the fiscal growth factor for the then current fiscal year. As used in this section, "fiscal growth factor" has the same meaning as the term is defined in RCW 43.135.025.

(b) The director may round off a rate increase under subsection (1) of this section. However, no rate increase may exceed the applicable fiscal growth factor.

(c) By June 1 of each year, the director will make available a chart of the new rates that will take effect on the immediately following July 1.

(2) Mortgage broker licenses.

Mortgage broker - license application fee	\$(370.00) <u>371.00</u>
Mortgage broker - annual assessment (due upon initial licensing, then an annual renewal fee, per location)	\$530.00
Mortgage broker late renewal assessment (fifty percent of annual assessment)	\$265.00
Mortgage broker branch office - license application fee	\$185.00
Mortgage broker branch office - annual assessment (annual renewal fee, per location)	\$530.00
Mortgage broker - license amendment	No fee
<u>Mortgage broker - change of designated broker</u>	<u>\$25.00</u>

(3) Loan originator licenses.

Loan originator - license application fee	\$125.00
Loan originator - annual assessment (not due until first renewal; then an annual renewal fee((-per license)))	\$125.00
Loan originator late renewal assessment (fifty percent of annual assessment)	\$62.50

((Loan originator - additional assessment (charged for each association with additional mortgage brokers)	\$75.00
Loan originator - annual assessment (renewal fee of additional licenses)	\$75.00))
Loan originator - cancel association with any mortgage broker	No fee
<u>Loan originator - license amendment - add a mortgage broker relationship</u>	<u>\$50.00</u>
Loan originator - license amendment - <u>other</u>	No fee

When the realignment of license expiration or renewal dates results in a partial year of licensing, the department will impose a proportionate fee structure to accommodate that realignment.

(4) Examinations.

(a) In Washington. The department does not charge a licensee located in Washington for the costs of an examination.

(b) Outside of Washington. The department will charge the licensee for travel costs.

(c) If the department hires professionals, specialists, or both to examine an out-of-state licensee, the professional, specialist, or both will be considered examiners for the purpose of billing the licensee for travel costs.

(5) Investigations.

(a) The department will charge forty-eight dollars per hour for an examiner's time devoted to an investigation.

(b) The department will bill the licensee for the costs of services from attorneys, accountants, or other professionals or specialists retained by the director to aid in the investigation.

(6) **Travel costs.** If the mortgage business is out-of-state, the department will charge the business the travel costs associated with an examination or investigation. Travel costs include, but are not limited to, transportation costs (airfare, rental cars), meals, and lodging.

(7) **How is the annual assessment calculated?** The assessment is a flat rate per license.

(8) **How does the department use license application fees?** The fees collected by the department are used to pay the costs of administering the act.

AMENDATORY SECTION (Amending WSR 06-23-137, filed 11/21/06, effective 1/1/07)

WAC 208-660-600 Administration and facilitation of continuing education. (1) **Who may offer continuing education courses to principals, designated mortgage brokers, and loan originators?** Continuing education may be offered by:

(a) Course providers with courses of education approved by the director; or

(b) Course providers with courses of education approved by professional organizations approved by the director.

(2) **What does it mean to offer and administer a course of education?** Offering and administering a course of education is the creation of a curriculum and the administrative processes to operate and maintain the curriculum. See the department's approval standards in subsections (7) and ~~((13))~~ (14) of this section.

(3) **What is a "course of education" under the act?** A course of education is formal training that satisfies all or part of the continuing education requirements of the act and these rules.

(4) **What is a "course provider" under the act?** A course provider is a person or organization that provides continuing education. Course providers may provide education that meets the requirements of the act and these rules by applying for and receiving approval from the department for a specific course of education.

(5) **What is a "professional organization" under the act?** A professional organization is an organization with at least ten members created for the primary purpose of furthering the professional interests of its members, protecting the public interest, or both. Education must be an essential element of the professional organization's purpose. A professional organization must have the director's approval to offer and administer courses of education.

(6) **If I am a course provider not affiliated with a professional organization, how do I obtain approval for my courses of education?** You must apply to the department for course approval. If the department approves the course, you will be issued a certificate of approval that will be effective for two years from the date of issuance.

(7) **What standard is required and what will the department review when considering approval of continuing education provided by course providers not affiliated with professional organizations?** Continuing education courses must provide the course taker with a working knowledge of, and competency in, the subject matter. To ensure this standard, the department will review the following when considering approval of education courses:

- (a) The instructor's experience and qualifications;
- (b) Whether the instructor or proposed course of education has been approved, denied, or rescinded by the department in the past; and
- (c) The course materials and lesson plans for the proposed courses. Each course must run a minimum of three hours; the materials and lesson plans must have the content to support a presentation of this length.

(8) **If I am a course provider with courses of education approved by a professional organization, may I also offer courses of education unaffiliated with the professional organization?** Yes. However, your courses of education unaffiliated with the professional organization must be approved by the department.

(9) **May the department rescind approval of a course provider's course of education?** Yes. The department may rescind approval of a course of education;

(a) Upon a determination that the course of education does not meet the standards in subsection (7) of this section; or

(b) If the course provider does not provide the required quarterly reports described in subsection (13) of this section.

(10) **What action must a course provider take if notified by the department that its course of education has been rescinded?** The course provider must immediately:

- (a) Cease advertising or soliciting for the course of education;
- (b) Inform registered course takers of the department's rescission of course approval, and cancel the course of education; and
- (c) Refund any fees paid by course takers for the course.

(11) **May a course provider appeal the department's decision to deny or rescind course approval?** Yes. A course provider may appeal the department's decision to deny or rescind a course. The course provider must appeal the decision to the department within twenty days of being notified by the department of the decision.

(12) **If a course provider has appealed the department's denial or rescission of a course of education, must it still take the immediate action in subsection (10) of this section?** Yes. A course provider appealing a department decision about a course of education must comply with subsection (10) of this section.

(13) I am a course provider who provides approved continuing education courses directly to licensees, or I provide courses with the approval of a professional organization. What reports must I provide to the department? You must provide quarterly reports to the department, in a form prescribed by the director. The reports must be received by the department no later than April 10, July 10, October 10, and January 10 of each year. The reports must contain the following information:

- (a) The course taker's name;
- (b) The course taker's license number, or Social Security number;
- (c) The name of the course;
- (d) The date the course was taken; and
- (e) Whether the course taker received a certificate of satisfactory completion.

If you provide the reports electronically, the data must be encrypted as prescribed by the director.

(14) **What standards will the department review when considering approving professional organizations to offer and administer courses of education under the act and rules?** The department will review the following:

- (a) A description of the course of education curriculum that satisfies the content of continuing education under subsection ~~((20))~~ (22) of this section;
- (b) Whether the professional organization has sufficient procedures and guidelines to:
 - (i) Establish a course(s) of education and approve a course provider(s);
 - (ii) Audit and evaluate an approved course(s) of education and course provider(s);
 - (iii) Remove courses and providers from the professional organization's curriculum;
 - (iv) Provide board reconsideration of denial or removal of a course of education or a course provider;
 - (v) Ascertain the identity of course of education takers;

(vi) Issue certificates of satisfactory completion, that include, at a minimum, the course taker's name, the course provider's name, the course title, and the date of course completion;

(vii) Collect, hold, disburse and refund course of education fees;

(c) Whether the professional organization requires members to adhere to an established code of conduct or ethics.

~~((14))~~ **(15) Is the department liable for a professional organization's decision to approve, deny, or revoke authorization for a course provider to offer courses of education?** No. The department is not liable for a professional organization's decision to approve, deny, or revoke a course provider's authorization to provide courses of education for the professional organization.

~~((15))~~ **(16) Is the department liable for a course provider's contractual relationship with a professional organization?** No. Course providers independently contract with professional organizations and the department is not liable for the consequences of that relationship.

~~((16))~~ **(17) May the department remove a professional organization's authorization to offer and administer courses of education?** Yes. The department may rescind a professional organization's authorization to offer and administer courses of education;

(a) Upon a determination that the professional organization fails to meet subsection ~~((13))~~ **(14)** of this section; or

(b) If the professional organization fails to provide the required quarterly reports described in subsection (21) of this section.

~~((17))~~ **(18) What action must a professional organization take if notified by the department that its authorization has been rescinded?** The professional organization must immediately:

(a) Cease advertising or soliciting for all courses of education;

(b) Inform registered course takers of the department's rescission of approval, and cancel the courses of education; and

(c) Refund any fees paid by course takers for the courses.

~~((18))~~ **(19) May a professional organization appeal the department's decision to deny or rescind authorization?** Yes. A professional organization may appeal the department's decision to deny or rescind the professional organization's authorization to approve course providers. The professional organization must appeal the decision to the department within twenty days of being notified by the department of the decision.

~~((19))~~ **(20) If a professional organization has appealed the department's denial or rescission of authorization, must it still take the immediate action in subsection ~~((17))~~ **(18)** of this section?** Yes. A professional organization appealing a department decision about a course provider or course of education must comply with subsection ~~((17))~~ **(18)** of this section.

~~((20))~~ **(21) When a professional organization is approved by the department to offer continuing education courses to licensees, and does so, what reports must the professional organization provide to the department?** The professional organization must provide quarterly reports

to the department, in a form prescribed by the director. The reports must be received by the department no later than April 10, July 10, October 10, and January 10 of each year. The reports must contain the following information:

(a) The course taker's name;

(b) The course taker's license number, or Social Security number if not currently licensed;

(c) The name of the course;

(d) The date the course was taken; and

(e) Whether the course taker received a certificate of satisfactory completion.

If you provide the reports electronically, the data must be encrypted as prescribed by the director.

(22) How long does department approval for a professional organization to offer continuing education courses last, and may the approval be renewed? Approval of a continuing education course is valid for two years. Approval may be renewed by applying to the director forty-five days prior to expiration of a current approval and providing detailed information about the course(s) and instructor(s) if they are to be changed.

~~((21))~~ **(23) What topics must be included as continuing education courses?** Continuing education courses must include some or all of the topics listed below. Courses may be designed to cover a range of topics or they may focus in detail on a single topic.

(a) **General.** Ethics in the mortgage industry.

The responsibilities and liabilities of the profession.

Arithmetical computations common to mortgage lending including without limitation, the computation of annual percentage rate, finance charge, amount financed, payment and amortization.

(b) **Compliance and internal audit standards.**

Proper use and application of the department's published standards and guidelines for examinations.

Internal audit and compliance practices, standards, methods and procedures.

Developing policies and procedures for regulatory compliance.

Responding to regulatory inquiries, directives, subpoenas and enforcement orders.

Training and supervision of mortgage professionals.

Establishing, managing, reconciling and reviewing a trust account (trust account compliance under the act and these rules).

(c) **Washington law and associated regulations.**

The Mortgage Broker Practices Act.

The Consumer Protection Act.

The Escrow Agent Registration Act.

The Usury Act.

Unfair practices with respect to real estate transactions (RCW 49.60.222).

Mortgage, deed of trust, and real estate contract statutes set forth in Title 61 RCW.

Real estate and appraisal law, including without limitation, the provisions of chapters 18.85 and 18.140 RCW.

Washington principal and agent law.

Any subsequent act or regulation applying to mortgage brokers.

(d) Federal law and associated regulations.

The Real Estate Settlement Procedures Act.
 Truth in Lending Act.
 Equal Credit Opportunity Act.
 Fair Credit Reporting Act.
 Fair Housing Act.
 Home Mortgage Disclosure Act.
 Community Reinvestment Act.
 Gramm-Leach Bliley Act.
 Home Ownership Protection Act.
 Bank Secrecy Act.
 Appraisal regulations.
 Underwriting.

Any subsequent act or regulation applying to mortgage brokers.

(e) Mortgage services and products.

Conventional.
 Reverse mortgages.
 FHA mortgages.
 VA mortgages.
 Nonprime mortgages.

Other products or services deemed relevant to continuing education by the department.

~~((22))~~ **(24) May the department audit or review a course of education?** Yes. The department may audit or review any continuing education course by registering for the course or attending the course of education unannounced by presenting the course provider with official identification prior to the start of the course. The department will not be charged any fee for official audit or review of the course of education.

**WSR 08-01-040
 PROPOSED RULES**

DEPARTMENT OF CORRECTIONS

[Filed December 11, 2007, 3:02 p.m.]

Original Notice.

Preproposal statement of inquiry was filed as WSR 07-21-098.

Title of Rule and Other Identifying Information: Clarify the process to be followed to request disclosure of public records from the agency.

Hearing Location(s): Department of Corrections, 7431 Linderson Way, Room 1028A, Tumwater, WA 98501, on January 28, 2008, at 10 a.m.

Date of Intended Adoption: January 29, 2008.

Submit Written Comments to: John Nispel, P.O. Box 41114, Olympia, WA 98504-1114, e-mail jrnispel@DOC1.wa.gov, fax (360) 664-2009, by January 25, 2008.

Assistance for Persons with Disabilities: Contact Kimberly French by January 23, 2008, (360) 725-8367.

Purpose of the Proposal and Its Anticipated Effects, Including Any Changes in Existing Rules: The adoption of this rule will clarify the method and location at which requests for public records may be made at the department. Because all requests will be made at a central location, the department will be able to more efficiently and effectively respond to records requests.

Reasons Supporting Proposal: To improve the efficiency and effectiveness of the department in responding to record requests.

Statutory Authority for Adoption: RCW 72.01.090.

Statute Being Implemented: RCW 42.56.040.

Rule is not necessitated by federal law, federal or state court decision.

Name of Proponent: Department of corrections, governmental.

Name of Agency Personnel Responsible for Drafting, Implementation and Enforcement: Denise L. Vaughan, DOC HQ Building, Tumwater, (360) 725-8854.

No small business economic impact statement has been prepared under chapter 19.85 RCW. Adoption of this rule will have no impact on small business.

A cost-benefit analysis is not required under RCW 34.05.328. Adoption of these rules have no economic impact.

December 12 [11], 2007

E. Vail

Secretary

AMENDATORY SECTION (Amending WSR 07-12-073, filed 6/5/07, effective 7/6/07)

WAC 137-08-060 Public records available. ~~((+))~~ Requests for any identifiable public record may be initiated at any office of the department during normal business hours.

~~(2))~~ The department shall at all times take the most timely possible action on requests for disclosure, and shall be required to respond in writing within five working days of receipt of the request for disclosure. The department's failure to so respond shall entitle the person seeking disclosure to petition the public disclosure officer pursuant to WAC 137-08-140.

AMENDATORY SECTION (Amending Order 82-3, filed 1/26/82)

WAC 137-08-090 Request for public records. (1) ~~((Unless waived by a public disclosure coordinator, all requests for the disclosure of a public record))~~ All requests for the disclosure of a public record, other than requests by incarcerated offenders for inspection of their health record or central file must be submitted in writing directly to the Department of Corrections Public Records Officer at P.O. Box 41118, Olympia, WA 98504 or via e-mail at publicdisclosureunit@doc1.wa.gov identifying the record sought with reasonable certainty. The written request (~~((may))~~) should include:

(a) The name of the person requesting the record and their contact information;

(b) The ~~((time of day and))~~ calendar date on which the request is made~~((;))~~; and~~((;))~~

(c) The ~~((nature of the request))~~ records requested.

Incarcerated offenders under the authority of the department of corrections shall submit requests to inspect their own health record or central file to the records manager at the facility in which, they are currently incarcerated.

(2) A request for disclosure shall be made during customary business hours.

(3) If the public record contains material exempt from disclosure pursuant to law, including those laws cited in WAC 137-08-150, the department must provide the person requesting disclosure with a written explanation for the non-disclosure, pursuant to WAC 137-08-130.

(4) Any person continuing to seek disclosure, after having received a written explanation for nondisclosure pursuant to WAC 137-08-130, may request a review under the provisions of WAC 137-08-140.

(5) When a person's identity is relevant to an exemption, that person may be required to provide personal identification.

(6) Nothing in this section or elsewhere in this chapter shall be construed to require the department to compile statistics or other information from material contained in public records, where doing so would unduly interfere with other essential functions of the department and is not required for litigation by rules of pretrial discovery.

WSR 08-01-056

PROPOSED RULES

DEPARTMENT OF AGRICULTURE

[Filed December 13, 2007, 2:59 p.m.]

Original Notice.

Preproposal statement of inquiry was filed as WSR 07-21-149.

Title of Rule and Other Identifying Information: The department proposes to amend chapter 16-409 WAC, Washington standards for asparagus, by making changes to WAC 16-409-024 Size requirements for Washington asparagus grades. Minor changes are also proposed for chapter 16-409 WAC to increase its clarity.

Hearing Location(s): Educational Service District 123, Grand Ronde Room, 3918 West Court Street, Pasco, WA 99301, phone (509) 547-8441, on Tuesday, January 29, 2008, at 1:00 p.m.

Date of Intended Adoption: February 6, 2008.

Submit Written Comments to: Teresa Norman, Rules Coordinator, Washington State Department of Agriculture, P.O. Box 42560, Olympia, WA 98504-2560, e-mail WSDARulesComments@agr.wa.gov, fax (360) 902-2092, by 5:00 p.m. on January 30, 2008.

Assistance for Persons with Disabilities: Contact Virginia Walsh by January 23, 2008, (360) 902-1976, TTY 800-833-6388.

Purpose of the Proposal and Its Anticipated Effects, Including Any Changes in Existing Rules: The department proposes to change the size small designation found at WAC 16-409-024(5) from "*less than 5/16*" inch in diameter to "*at least 3/16*" inch in diameter. The department proposes to make any minor changes that may be needed to increase the rule's clarity.

Reasons Supporting Proposal: Asparagus industry representatives have requested the department consider making the proposed change. This change will remove existing

wording that mandates a cap on the small designation packing size.

Statutory Authority for Adoption: Chapter 15.17 RCW, Standards of grades and packs and chapter 34.05 RCW, Administrative Procedure Act.

Statute Being Implemented: Chapter 15.17 RCW, Standards of grades and packs.

Rule is not necessitated by federal law, federal or state court decision.

Name of Proponent: Washington state department of agriculture, governmental.

Name of Agency Personnel Responsible for Drafting, Implementation and Enforcement: Jim Quigley, Program Manager, P.O. Box 42560, Olympia, WA 98504-2560, (360) 902-1833.

No small business economic impact statement has been prepared under chapter 19.85 RCW. RCW 19.85.030 (1)(a) requires an agency to prepare a small business economic impact statement (SBEIS) for proposed rules that impose a more than minor cost on the business in an industry. The proposed change would not impose "more than minor impact" upon the regulated industry.

RCW 19.85.040(1) requires that an agency determine whether the proposed rule will have a disproportionate impact on small businesses by comparing the cost of compliance for small business with the cost of compliance for the 10% of businesses that are the largest businesses required to comply. The proposed change would not impose "more than minor impact" upon the regulated industry.

A cost-benefit analysis is not required under RCW 34.05.328. Washington state department of agriculture is not a named agency in RCW 34.05.328.

December 13, 2007

Dennis Hannapel
Assistant Director

AMENDATORY SECTION (Amending WSR 07-06-047, filed 3/1/07, effective 4/1/07)

WAC 16-409-024 Size requirements for Washington asparagus grades. The following size designations apply to all grades of asparagus in Washington state.

- (1) Jumbo: Stalks at least 13/16 inch in diameter.
- (2) Extra large: Stalks at least 10/16 inch in diameter.
- (3) Large: Stalks at least 7/16 inch in diameter.
- (4) Standard: Stalks at least 5/16 inch in diameter.
- (5) Small: Stalks (~~less than 5/16~~) at least 3/16 inch in diameter.
- (6) All size designations, as defined in WAC 16-409-024, may be packed in all grades and in all containers.

WSR 08-01-061

PROPOSED RULES

PUBLIC DISCLOSURE COMMISSION

[Filed December 14, 2007, 9:38 a.m.]

Continuance of WSR 07-21-042 [and 07-22-042].

Preproposal statement of inquiry was filed as WSR 07-16-001.

Title of Rule and Other Identifying Information: New WAC 390-05-225, relating to registered voter counts for the purposes of chapter 42.17 RCW.

Hearing Location(s): Commission Hearing Room, 711 Capitol Way, Room 206, Olympia, WA 98504, on January 24, 2008, at 9:30 a.m.

Date of Intended Adoption: January 24, 2008.

Submit Written Comments to: Doug Ellis, Public Disclosure Commission, P.O. Box 40908, Olympia, WA 98504-0908, e-mail dellis@pdc.wa.gov, fax (360) 753-1112, by January 21, 2008.

Assistance for Persons with Disabilities: Contact Kami Madsen by phone (360) 586-0544.

Purpose of the Proposal and Its Anticipated Effects, Including Any Changes in Existing Rules: To change the date of the public hearing to January 24, 2008.

Statutory Authority for Adoption: RCW 42.17.370(1).

Statute Being Implemented: RCW 42.17.030 and 42.17.405.

Rule is not necessitated by federal law, federal or state court decision.

Agency Comments or Recommendations, if any, as to Statutory Language, Implementation, Enforcement, and Fiscal Matters: The new rule is designed to provide guidance to county auditors and provide uniformity in calculating the count of registered voters for the purposes under chapter 42.17 RCW.

Name of Proponent: Public disclosure commission, governmental.

Name of Agency Personnel Responsible for Drafting and Implementation: Doug Ellis, 711 Capitol Way, Room 206, Olympia, WA 98504, (360) 664-2735; and Enforcement: Phil Stutzman, 711 Capitol Way, Room 206, Olympia, WA 98504, (360) 664-8853.

No small business economic impact statement has been prepared under chapter 19.85 RCW. The implementation of these rule amendments has minimal impact on small businesses.

A cost-benefit analysis is not required under RCW 34.05.328. The public disclosure commission (PDC) is not an agency listed in subsection (5)(a)(i) of section 201. Further, the PDC does not voluntarily make section 201 applicable to the adoption of these rules pursuant to subsection (5)(a)(i) of section 201, and, to date, JARRC has not made section 201 application to the adoption of these rules.

December 11, 2007

Vicki Rippie

Executive Director

NEW SECTION

WAC 390-05-225 Registered voters—Count or number of. In accordance with RCW 29A.08.130, for purposes of chapter 42.17 RCW and Title 390 WAC, the count or number of registered voters shall not include inactive voters.

WSR 08-01-074

PROPOSED RULES

DEPARTMENT OF FISH AND WILDLIFE

[Filed December 14, 2007, 4:21 p.m.]

Original Notice.

Preproposal statement of inquiry was filed as WSR 06-17-071.

Title of Rule and Other Identifying Information: Rule changes relating to hydraulic project approvals for mineral prospecting activities. Includes WAC 220-110-020, 220-110-030, 220-110-031, 220-110-200, 220-110-201, 220-110-202, 220-110-203, 220-110-340, 220-110-350, and 220-110-360; also repeals WAC 220-110-204, 220-110-205, 220-110-206, 220-110-207, 220-110-208, and 220-110-209.

Hearing Location(s): Natural Resources Building, Room 172, 1111 Washington Avenue S.W., Olympia, 98504, on February 1-2, 2008, at 8:00 a.m.

Date of Intended Adoption: March 7, 2008.

Submit Written Comments to: Lisa Wood, 600 Capitol Way North, Olympia, WA 98501-1091, e-mail sepadesk@dfw.wa.gov, fax (360) 902-2946, by January 23, 2008.

Assistance for Persons with Disabilities: Contact Susan Yeager at TTY (360) 902-2207 or (360) 902-2267.

Purpose of the Proposal and Its Anticipated Effects, Including Any Changes in Existing Rules: The current rules on this subject were adopted in 1998 and do not reflect the current knowledge of impacts to fish life and habitat caused by mineral prospecting. The proposed rules modify permitted activities, equipment and tools, timing and location of authorized mineral prospecting activities under authority of the Gold and Fish pamphlet, application procedures for standard and pamphlet hydraulic project approvals, appeal procedures, and violation penalties.

Reasons Supporting Proposal: The proposed rules reflect the most reasonable methods of allowing mineral prospecting activities as required by RCW 77.55.091 while also protecting fish life from the impacts of those activities. The proposed rules also clarify various administrative procedures associated with applying for, or appealing, standard and pamphlet hydraulic project approvals.

Statutory Authority for Adoption: RCW 77.12.047 and 77.04.020.

Statute Being Implemented: RCW 77.55.091.

Rule is not necessitated by federal law, federal or state court decision.

Name of Proponent: Washington department of fish and wildlife, governmental.

Name of Agency Personnel Responsible for Drafting: Pat Chapman, 1111 Washington Street, Olympia, (360) 902-2571; Implementation: Greg Hueckel, 1111 Washington Street, Olympia, (360) 902-2416; and Enforcement: Bruce Bjork, 1111 Washington Street, Olympia, (360) 902-2373.

No small business economic impact statement has been prepared under chapter 19.85 RCW. The Washington department of fish and wildlife, in conjunction with the group of stakeholders who helped develop the proposed rules, determined that the rules will not significantly impact businesses required to follow the rules.

A cost-benefit analysis is required under RCW 34.05.328. A preliminary cost-benefit analysis may be obtained by contacting Lisa Wood, 600 Capitol Way North, Olympia, WA 98501-1091, phone (360) 902-2260, fax (360) 902-2946, e-mail sepadesk@dfw.wa.gov.

December 14, 2007
Loreva M. Preuss
Rules Coordinator

AMENDATORY SECTION (Amending Order 98-252, filed 12/16/98, effective 1/16/99)

WAC 220-110-206 Authorized work times and ~~((watercourses)) mineral prospecting equipment restrictions by specific state waters for mineral prospecting and placer mining projects ((by specific watercourse, except the Columbia and Snake rivers, lakes, salt waters and waters within National Park boundaries using Class I and H equipment)).~~ Mineral prospecting and placer mining ~~((using Class I and H equipment pursuant to WAC 220-110-203 and 220-110-204))~~ under WAC 220-110-202 shall only occur in ~~((watercourses)) the state waters, with the equipment restrictions, and during the times specified in the following table((:)).~~

(1) The general work time for a county applies to all ~~((streams)) state waters~~ within that county, unless otherwise indicated ~~((under specific stream and tributary work times))~~ in the table.

(2) The work time for a listed ~~((stream)) state water~~ applies to all its tributaries, unless otherwise indicated. Some ~~((streams flow through)) state waters occur in~~ multiple counties. Check the listing for the county in which mineral prospecting or placer mining is to be conducted to determine the work time for that ~~((stream)) state water~~.

(3) Where a tributary is listed as a boundary, that boundary shall be the line perpendicular to the receiving stream that is projected from the most upstream point of the tributary mouth to the opposite bank of the receiving stream. ~~((See Figure 1((:)).~~

~~((Figure 1. Stream boundary line))~~

~~((STRICKEN GRAPHIC~~

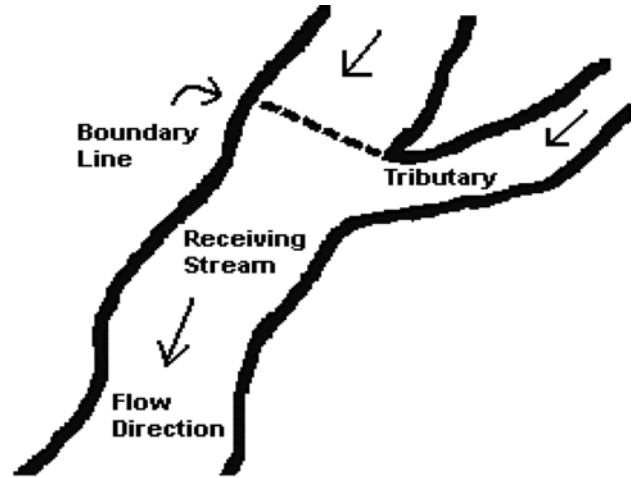
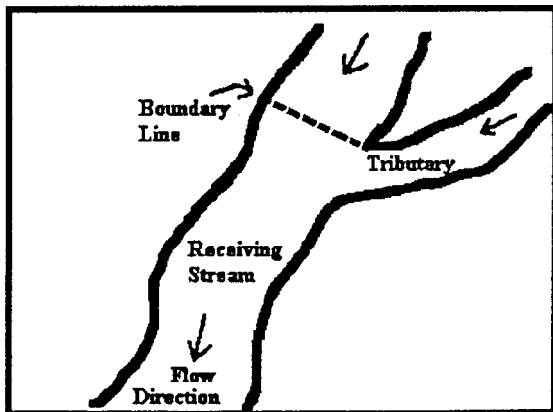

Figure 1: Stream boundary line

(4) Mineral prospecting and placer mining within ~~((two hundred feet landward of the ordinary high water line in))~~ state waters listed as "submit application" ~~((or "closed" is))~~ are not authorized under the *Gold and Fish* pamphlet. Site review and a written HPA ~~((is))~~ are required for these state waters.

(5) Mineral prospecting using mineral prospecting equipment with four inch maximum suction intake hose diameters is authorized only in the listed state waters, and any tributaries to them, unless otherwise indicated in the table.

(6) Mineral prospecting using mineral prospecting equipment with five inch maximum suction intake hose diameters is authorized only in the listed state waters in the following table. You may not use mineral prospecting equipment with suction intake hose diameters greater than four inches in tributaries of these state waters.



~~STRICKEN GRAPHIC))~~

~~((AUTHORIZED WORK TIMES FOR MINERAL PROSPECTING AND PLACER MINING USING CLASS I AND II EQUIPMENT~~

COUNTY	GENERAL WORK TIMES	SPECIFIC STREAM & TRIBUTARY WORK TIMES	
		STREAM & ALL TRIBUTARIES	WORK TIME
Adams	July 1—October 31	Esquatzel Creek	July 1—September 30
		Palouse River	June 15—October 15
Asotin	July 1—October 31	Asotin Creek	July 15—August 15
		Grande Ronde River	July 15—August 15
Benton	June 1—September 30	Yakima River tributaries	July 1—September 30
		—Corral Creek	July 15—September 30
		—Spring Creek	July 15—September 30
Chelan	July 1—August 15	Beaver Creek	July 1—October 31
		Coloekum Creek	July 1—October 31
		Peshastin Creek	
		—mouth to Negro Creek	July 1—August 15
		—above Negro Creek	July 1—October 31
		Squilehuek Creek	July 1—October 31
		Stemilt Creek	
		—mouth to falls	July 1—October 31
		Wenatchee River	
		—mouth to lake	July 1—September 30
Clallam	July 15—September 30	Bogaehiel River	July 15—August 15
		Calawah River	July 15—August 15
		Clallum River	July 15—September 15
		Dungeness River	submit application
		Elwha	
		—mouth to lower dam	July 1—August 15
		Hoko River	July 15—September 15
		Jimmycomelately Creek	submit application
		Lyre River	July 15—September 15
		McDonald Creek	July 1—August 15
		Morse Creek	July 1—August 15
		Pysht River	July 15—September 15
		Sekiu River	July 15—September 15
		Sol Due River	July 15—August 15
Sooes River	July 15—September 15		
Clark	July 1—September 30	Lewis River	
		—mouth to forks	June 1—October 31
		—East Fork Lewis River	
		—mouth to LaCenter road bridge	July 1—October 31
		—above LaCenter & all tributaries	submit application
		—North Fork Lewis River	
		—mouth to Merwin Dam	August 1—August 31
		—Cedar Creek	August 1—September 30
—Merwin Dam to Swift Dam	July 1—July 31		
Lake River	June 1—October 31		

COUNTY	GENERAL WORK TIMES	SPECIFIC STREAM & TRIBUTARY WORK TIMES	
		STREAM & ALL TRIBUTARIES	WORK TIME
		Washougal River	August 1—August 31
Columbia	July 15—October 31	Tucannon River	July 15—August 15
		Touche River	July 15—August 15
Cowlitz	July 1—September 30	Cowlitz River	August 1—August 31
		—Coweeman River	August 1—September 30
		—Toutle River	submit application
		Kalama River	August 1—August 31
		Lewis River	
		—mouth to forks	June 1—October 31
		—North Fork Lewis River	
		—mouth to Merwin Dam	August 1—August 31
		—Merwin Dam to Lower Falls	July 1—July 31
		—above Lower Falls	July 1—October 31
Douglas	July 1—October 31	None	
Ferry	July 1—August 31	None	
Franklin	June 1—September 30	Palouse River	
		—above falls	June 15—October 15
Garfield	July 15—October 31	Asotin Creek	July 15—August 15
		Tucannon River	July 15—August 15
Grant	July 1—October 31	None	
Grays Harbor	July 15—October 31	Cedar Creek	July 15—September 30
		Chehalis River	
		—mouth to Porter Creek	June 1—October 31
		—above Porter Creek	July 15—September 30
		Cloquallum River	July 15—September 30
		Copalis River	July 15—October 15
		Elk River	July 15—September 30
		Hoquiam River	July 15—October 15
		Humptulips River	July 15—October 15
		Johns River	July 15—September 30
		Moelips River	July 15—October 15
		North River	July 15—September 15
		Porter Creek	July 15—September 30
		Quinault River	July 15—August 31
		Satsop River	July 15—August 31
Wishkah River	July 15—October 15		
Wynoochee River	July 15—October 15		
Island	June 15—September 15	None	
Jefferson	July 15—October 31	Big Quileene River	July 15—August 31
		Bogachiel River	July 15—August 15
		Chimacum Creek	July 15—August 31
		Clearwater River	July 15—September 15

COUNTY	GENERAL WORK TIMES	SPECIFIC STREAM & TRIBUTARY WORK TIMES	
		STREAM & ALL TRIBUTARIES	WORK TIME
		Donovan Creek	July 15—September 30
		Dosewallips River	July 15—August 31
		Duckabush River	July 15—August 31
		Dungeness River tributaries	submit application
		Hoh River	July 15—August 15
		Little Quilecene River	July 15—August 31
		Matheny Creek	July 15—September 15
		Queets River	July 15—September 15
		Quinault River	July 15—August 15
		Salmon Creek	submit application
		Sams River	July 15—September 15
		Snow Creek	submit application
King	July 1—September 30	Green River (Duwamish)	August 1—August 31
		Greenwater River	July 15—August 31
		Lake Washington tributaries including Cedar and Sammamish rivers	July 1—August 31
		—Issaquah Creek	June 15—July 31
		Snoqualmie River	
		—mouth to Snoqualmie Falls	July 1—September 15
		—Snoqualmie Falls to mouth of South Fork Snoqualmie River	June 15—October 31
		—North, Middle and South Fork Snoqualmie rivers and tributaries	July 15—October 31
		—Tolt River	
		—mouth to forks	July 15—October 31
		—North Fork	
		—mouth to Yellow Creek	July 15—September 15
		—above Yellow Creek	July 15—October 31
		—mouth to dam	July 15—September 15
		—above dam	July 15—October 31
		White River	July 15—August 31
Kittitas	June 1—September 30	Coloekum Creek	July 1—October 31
		Yakima River	
		—above Roza Dam	submit application
		—Gold Creek (Lake Keechelus)	July 1—July 31
		—Kaehess River	
		—above Lake Kaehess	July 1—July 31
		—Box Canyon Creek (Lake Kaehess)	July 1—July 31
		—Little Naehes River	July 15—August 15
		—Wenas Creek	August 1—October 31
		—other Yakima River tributaries	July 15—August 31

COUNTY	GENERAL WORK TIMES	SPECIFIC STREAM & TRIBUTARY WORK TIMES	
		STREAM & ALL TRIBUTARIES	WORK TIME
Kitsap	July 15 – October 31	Seabeek Creek	July 15 – August 31
		Gorst Creek	July 15 – August 31
Klickitat	July 1 – September 30	Klickitat River	July 1 – August 15
		White Salmon River	July 1 – August 15
Lewis	July 1 – September 30	Chehalis River	
		—upstream of South Fork	
		Chehalis River confluence	July 1 – August 31
		Cispus River	
		—mouth to Walupt Creek	August 1 – August 31
		—above Walupt Creek	submit application
		—McCoy Creek	August 1 – September 30
		Connelly Creek	August 1 – September 30
		Cowlitz River	August 1 – August 31
		Newaukum River	July 1 – August 31
		Nisqually River	
		—above Alder Lake	July 1 – September 30
		Skookumehuck River	July 1 – August 31
		Tilton River	August 1 – September 30
		Toutle River	
—tributaries	submit application		
Walupt Creek	submit application		
Paekwood Lake tributaries	submit application		
Lincoln	June 15 – October 15	None	
Mason	July 15 – October 31	Cloquallum Creek	July 15 – September 30
		Coulter Creek	July 15 – September 15
		Hamma Hamma River	
		—mouth to falls	July 15 – August 31
		—John Creek	July 15 – August 31
		Johns Creek	July 15 – August 31
		Lilliwaup River	
		—below falls	July 15 – August 31
		—above falls	July 1 – October 31
		Mill Creek	July 15 – October 15
		Satsop River	July 15 – August 31
		Schaerer Creek	July 15 – August 31
		Sherwood Creek	July 15 – September 15
		Skokomish River	July 15 – September 15
		Tahuya River	July 15 – September 15
Twanoh Creek	June 1 – October 31		
Union River	June 1 – September 15		
Okanogan	July 1 – August 15	Aneas Creek	
		—mouth to falls	July 1 – October 31
		Chewiliken Creek	
		—mouth to falls	July 1 – October 31

COUNTY	GENERAL WORK TIMES	SPECIFIC STREAM & TRIBUTARY WORK TIMES			
		STREAM & ALL TRIBUTARIES	WORK TIME		
Pacific	July 15 – September 30	Chilwist Creek —mouth to falls	July 1 – October 31		
		Methow River —mouth to Carleton	July 1 – September 30		
		Mosquito Creek	July 1 – October 31		
		Nine Mile Creek	July 1 – October 31		
		Omak Creek —mouth to falls	July 1 – October 31		
		Similkameen River —mainstem	July 1 – September 30		
		—all Similkameen River tributaries	July 1 – August 15		
		Tunk Creek —mouth to falls	July 1 – October 31		
		Chehalis River	July 1 – August 31		
		Chinook River	August 1 – August 31		
		Grays River	August 1 – September 30		
		North River	July 15 – September 15		
		Pend Oreille	July 1 – August 31	Big Muddy Creek	June 1 – August 31
				Bracket Creek	June 1 – August 31
Calispel Creek —mouth to Calispel Lake	June 1 – August 31				
Exposure Creek	June 1 – August 31				
Kent Creek	June 1 – August 31				
Lime Creek	June 1 – August 31				
Little Spokane River	June 15 – August 31				
Lodge Creek	June 1 – August 31				
Marshall Creek	June 1 – August 31				
Pee-Wee Creek —above falls	June 1 – October 31				
Renshaw Creek	June 1 – August 31				
Pierce	July 15 – August 31			Nisqually River —mouth to Alder Lake	July 1 – August 31
				—tributaries below Alder Lake	submit application
				—above Alder Lake & tributaries	July 15 – September 15
		Carbon River	July 15 – August 31		
		—South Prairie Creek —mouth to Forest Service road #7710	July 15 – September 15		
		—above Forest Service road #7710	July 1 – October 31		
		—Voights Creek —mouth to falls	July 15 – September 15		
		—above falls	July 15 – October 31		
		—Wilkeson Creek —mouth to Snell Lake	July 1 – September 30		
		—above Snell Lake	July 1 – October 31		

COUNTY	GENERAL WORK TIMES	SPECIFIC STREAM & TRIBUTARY WORK TIMES	
		STREAM & ALL TRIBUTARIES	WORK TIME
		Rocky Creek	July 15 – September 30
San Juan	June 1 – August 31	None	
Skagit	July 1 – September 30	Baker River	
		—mouth to dam	June 15 – August 31
		Cascade River	June 15 – July 15
		Hlabot Creek	June 15 – July 31
		Samish River	submit application
		Skagit River	
		—mouth to Sauk River	June 15 – August 31
		—above Sauk River	June 15 – July 31
		—Sauk River	July 15 – August 15
		—Suiattle River	July 15 – August 15
		Nooksack River	submit application
		Skamania	July 1 – September 30
Lewis River			
—East Fork Lewis River	submit application		
—North Fork Lewis River			
—Cougar Creek	June 1 – July 31		
—Merwin Dam to Lower Falls & tributaries	July 1 – July 31		
—above Lower Falls	July 1 – October 31		
Little White Salmon River	July 1 – August 31		
McCoy Creek	August 1 – September 30		
Washougal River	August 1 – August 31		
White Salmon River	July 1 – August 31		
Wind River	August 1 – August 15		
Snohomish	July 1 – September 30	Lake Washington tributaries	July 1 – August 31
		Sauk River	July 15 – August 15
		—Suiattle River	July 15 – August 15
		Snohomish River	
		—mouth to Highway 9	June 1 – October 31
		—above Highway 9	July 1 – August 31
		—Pilehuck River	July 1 – August 31
		—mouth to city of Snohomish diversions dam	July 1 – August 31
		—above city of Snohomish diversion dam	July 1 – September 15
		—Skykomish River	
		—mouth to forks	July 1 – August 31
		—North Fork Skykomish River	
		—mouth to San Juan campground	July 1 – August 31
		—San Juan campground to Deer Falls	submit application
		—above Deer Falls	July 15 – October 31
—Salmon Creek	submit application		
—South Fork Skykomish River			

COUNTY	GENERAL WORK TIMES	SPECIFIC STREAM & TRIBUTARY WORK TIMES	
		STREAM & ALL TRIBUTARIES	WORK TIME
		— mouth to Sunset Falls	July 1—August 31
		— Sunset Falls to Alpine Falls	July 1—September 15
		— above Alpine Falls	July 15—October 31
		— Beekler River	
		— mouth to Boulder Creek	July 1—September 15
		— above Boulder Creek	July 15—October 31
		— Rapid River	
		— mouth to Meadow Creek	July 15—September 15
		— above Meadow Creek	July 15—October 31
		— Foss River	
		— mouth to forks	July 15—September 15
		— East Fork Foss River	submit application
		— West Fork Foss River	July 15—October 31
		— Miller River	
		— mouth to forks	July 1—September 15
		— above forks	July 1—October 31
		— Olney Creek	
		— mouth to Olney Falls	July 1—September 15
		— above Olney Falls	July 1—October 31
		— Sultan River	
		— mouth to old diversion dam	July 1—August 31
		— old diversion dam to Culmbaek Dam	July 1—October 31
		— tributaries above Culmbaek Dam	August 1—October 31
		— Wallace River	
		— mouth to Wallace Falls	July 1—September 1
		— above Wallace Falls	July 1—October 31
		— Snoqualmie River	July 1—August 31
		— all other Snohomish River tributaries	July 1—August 31
		Stillaguamish River	
		— mouth to forks	July 1—August 31
		— North and South Fork Stillaguamish Rivers	July 1—August 15
		— Deer Creek	submit application
		— Canyon Creek	submit application
Spokane	June 15—August 31	Latah Creek	
		— mainstem	June 15—October 31
		— all Latah Creek tributaries	June 15—August 31
Stevens	July 1—August 31	Big Sheep Creek	
		— mouth to Sheep Creek Falls	submit application
		— above Sheep Creek Falls	July 1—August 31
Thurston	July 15—September 15	Cedar Creek	July 15—September 30
		Little Deschutes River	July 15—October 31
		McLane Creek	July 15—October 31
		Nisqually River	
		— mainstem	July 1—August 31

COUNTY	GENERAL WORK TIMES	SPECIFIC STREAM & TRIBUTARY WORK TIMES	
		STREAM & ALL TRIBUTARIES	WORK TIME
		—all Nisqually River tributaries	submit application
		Porter Creek	July 15—September 30
		Schneider Creek	July 1—October 31
		Skookumehuek River	July 1—August 31
		Woodard Creek	July 1—October 31
		Woodland Creek	July 1—October 31
Wahkiakum	July 15—September 15	Elochoman River	August 1—September 30
		Grays River	August 1—September 30
		Naselle River	July 15—September 30
Walla Walla	July 15—October 31	Touchet River	July 15—August 15
		Walla Walla River	July 15—August 15
Whatcom	July 1—September 30	Baker River	submit application
		Nooksack River	
		—above forks	submit application
		—all Nooksack River tributaries	submit application
		Ross Lake tributaries	submit application
		Samish River	submit application
		Skagit River	June 15—July 31
Whitman	June 15—October 15	Palouse River	
		—mouth to falls	June 1—September 30
Yakima	June 1—September 30	Klickitat River	July 1—August 15
		Yakima River	
		—mouth to Roza Dam	June 1—September 15
		—Naches River	
		—mouth to Tieton River	June 1—October 31
		—above confluence of Tieton River	June 1—August 15
		—Indian Creek (Rimrock Lake)	July 1—July 31
		—Tieton River	June 1—August 15
		—Little Naches River	July 15—August 15
		—Bumping River	July 15—August 15
		—American River	submit application
		—Rattlesnake Creek	July 15—August 15
		—Wenas Creek	August 1—October 31
		—all other Yakima River tributaries	July 15—August 31))

AUTHORIZED WORK TIMES AND MINERAL PROSPECTING EQUIPMENT RESTRICTIONS BY SPECIFIC STATE WATERS FOR MINERAL PROSPECTING AND PLACER MINING PROJECTS

<u>Washington Counties and State Waters</u> <u>Water Resource Inventory Area (WRIA) in parentheses</u>	<u>Mineral Prospecting Is Allowed Only Between These Dates</u>	<u>State Waters (and tributaries, unless otherwise indicated) in Which You May Use Mineral Prospecting Equipment With a Four Inch Maximum Suction Intake Hose Diameter</u>	<u>State Waters (NOT including tributaries) in Which You May Use Mineral Prospecting Equipment With a Five Inch Maximum Suction Intake Hose Diameter</u>
Adams County	July 1 - October 31	X	=
Crab Creek (41.0002)	July 16 - February 28	X	X

<u>Washington Counties and State Waters</u> <u>Water Resource Inventory Area (WRIA) in parentheses</u>	<u>Mineral Prospecting Is Allowed Only Between These Dates</u>	<u>State Waters (and tributaries, unless otherwise indicated) in Which You May Use Mineral Prospecting Equipment With a Four Inch Maximum Suction Intake Hose Diameter</u>	<u>State Waters (NOT including tributaries) in Which You May Use Mineral Prospecting Equipment With a Five Inch Maximum Suction Intake Hose Diameter</u>
<u>Esquatzel Creek (36.MISC)</u>	<u>June 1 - February 28</u>	<u>X</u>	<u>X</u>
<u>Palouse River (34.0003)</u>	<u>July 16 - February 28</u>	<u>X</u>	<u>X</u>
<u>Asotin County</u>	<u>July 16 - September 15</u>	<u>X</u>	<u>=</u>
<u>Snake River (35.0002)</u>	<u>See below</u>	<u>=</u>	<u>=</u>
<u>Alpowa Creek (35.1440)</u>	<u>July 16 - December 15</u>	<u>X</u>	<u>=</u>
<u>Asotin Creek (35.1716)</u>	<u>July 16 - August 15</u>	<u>X</u>	<u>=</u>
<u>Couse Creek (35.2147)</u>	<u>July 16 - December 15</u>	<u>X</u>	<u>=</u>
<u>Grande Ronde River (35.2192)</u>	<u>July 16 - September 15</u>	<u>X</u>	<u>X</u>
<u>Tenmile Creek (35.2100)</u>	<u>July 16 - December 15</u>	<u>X</u>	<u>=</u>
<u>Benton County</u>	<u>June 1 - September 30</u>	<u>X</u>	<u>=</u>
<u>Columbia River</u>	<u>See below</u>	<u>=</u>	<u>=</u>
<u>Glade Creek (31.0851)</u>	<u>August 1 - September 30</u>	<u>X</u>	<u>=</u>
<u>Yakima River (37.0002)</u>	<u>June 1 - September 15</u>	<u>X</u>	<u>X</u>
<u>Amon Creek (37.0009)</u>	<u>June 1 - September 30</u>	<u>X</u>	<u>=</u>
<u>Corral Creek (37.0002)</u>	<u>June 1 - September 30</u>	<u>X</u>	<u>=</u>
<u>Spring Creek (37.0205)</u>	<u>June 1 - September 30</u>	<u>X</u>	<u>=</u>
<u>Chelan County</u>	<u>July 16 - August 15</u>	<u>X</u>	<u>=</u>
<u>Columbia River</u>	<u>See below</u>	<u>=</u>	<u>=</u>
<u>Antoine Creek (49.0294) - Mouth to falls at river mile 1.0</u>	<u>July 1 - February 28</u>	<u>X</u>	<u>=</u>
<u>Antoine Creek (49.0294) - Upstream of falls at river mile 1.0</u>	<u>July 1 - March 31</u>	<u>X</u>	<u>=</u>
<u>Chelan River (47.0052) - Mouth to Chelan Dam</u>	<u>July 16 - September 30</u>	<u>X</u>	<u>X</u>
<u>Colockum Creek (40.0760)</u>	<u>July 1 - October 31</u>	<u>X</u>	<u>=</u>
<u>Entiat River (46.0042) - Mouth to Entiat Falls</u>	<u>July 16 - July 31</u>	<u>X</u>	<u>X</u>
<u>Entiat River (46.0042) - Upstream of Entiat Falls</u>	<u>July 16 - March 31</u>	<u>X</u>	<u>=</u>
<u>Crum Canyon (46.0107)</u>	<u>July 16 - March 31</u>	<u>X</u>	<u>=</u>
<u>Mad River (46.0125)</u>	<u>July 16 - July 31</u>	<u>X</u>	<u>=</u>
<u>Indian Creek (46.0128)</u>	<u>July 16 - February 28</u>	<u>X</u>	<u>=</u>
<u>Lake Chelan (47.0052)</u>	<u>Submit Application</u>	<u>=</u>	<u>=</u>
<u>Railroad Creek (47.0410)</u>	<u>July 16 - September 30</u>	<u>X</u>	<u>=</u>
<u>Stehekin River (47.0508)</u>	<u>Submit Application</u>	<u>=</u>	<u>=</u>
<u>Twenty-five Mile Creek (47.0195)</u>	<u>July 16 - September 30</u>	<u>X</u>	<u>=</u>
<u>Other Lake Chelan tributaries outside of North Cascades National Park</u>	<u>July 1 - August 15</u>	<u>X</u>	<u>=</u>
<u>Other Lake Chelan tributaries within North Cascades National Park</u>	<u>Submit Application</u>	<u>=</u>	<u>=</u>
<u>Number 1 Canyon (45.0011)</u>	<u>July 1 - February 28</u>	<u>X</u>	<u>=</u>
<u>Number 2 Canyon (45.0012)</u>	<u>July 1 - February 28</u>	<u>X</u>	<u>=</u>

<u>Washington Counties and State Waters</u> <u>Water Resource Inventory Area (WRIA) in parentheses</u>	<u>Mineral Prospecting Is Allowed Only Between These Dates</u>	<u>State Waters (and tributaries, unless otherwise indicated) in Which You May Use Mineral Prospecting Equipment With a Four Inch Maximum Suction Intake Hose Diameter</u>	<u>State Waters (NOT including tributaries) in Which You May Use Mineral Prospecting Equipment With a Five Inch Maximum Suction Intake Hose Diameter</u>
<u>Squilchuck Creek (40.0836) - Mouth to South Wenatchee Avenue</u>	<u>July 1 - September 30</u>	X	=
<u>Squilchuck Creek (40.0836) - Upstream of South Wenatchee Avenue</u>	<u>July 1 - February 28</u>	X	=
<u>Stemilt Creek (40.0808) - Mouth to falls</u>	<u>July 1 - September 30</u>	X	=
<u>Stemilt Creek (40.0808) - Upstream of falls</u>	<u>July 1 - February 28</u>	X	=
<u>Wenatchee River (45.0030) - Mouth to Lake Wenatchee</u>	<u>July 1 - July 31</u>	X	X
<u>Beaver Creek (45.0751)</u>	<u>July 1 - September 30</u>	X	=
<u>Chiwaukum Creek (45.0700)</u>	<u>July 1 - July 31</u>	X	=
<u>Chiwawa River (45.0759) - Mouth to Phelps Creek</u>	<u>July 1 - July 31</u>	X	X
<u>Chiwawa River (45.0759) - Upstream of Phelps Creek</u>	<u>July 1 - July 31</u>	X	=
<u>Deep Creek (45.0764)</u>	<u>July 1 - February 28</u>	X	=
<u>Phelps Creek (45.0875)</u>	<u>July 16 - August 15</u>	X	=
<u>Icicle Creek (45.0474) - Mouth to Johnny Creek</u>	<u>July 1 - July 31</u>	X	X
<u>Icicle Creek (45.0474) - Upstream of Johnny Creek</u>	<u>July 1 - July 31</u>	X	=
<u>Fourth of July Creek (45.0525)</u>	<u>July 1 - February 28</u>	X	=
<u>Lake Wenatchee (45.0030)</u>	<u>Submit Application</u>	=	=
<u>Little Wenatchee (45.0985) - Mouth to Wilderness Boundary</u>	<u>July 1 - July 31</u>	X	X
<u>Little Wenatchee (45.0985) - Upstream of Wilderness Boundary</u>	<u>July 1 - February 28</u>	X	=
<u>White River (45.1116) - Mouth to White River Falls</u>	<u>July 1 - July 31</u>	X	X
<u>White River (45.1116) - Upstream of White River Falls</u>	<u>July 1 - February 28</u>	X	=
<u>Nason Creek (45.0888)</u>	<u>July 1 - July 31</u>	X	=
<u>Peshastin Creek (45.0232) - Mouth to Negro Creek</u>	<u>July 16 - August 15</u>	X	=
<u>Peshastin Creek (45.0232) - Upstream of Negro Creek</u>	<u>August 1 - February 28</u>	X	=
<u>Ingalls Creek (45.0273) - Mouth to Cascade Creek</u>	<u>Submit Application</u>	=	=
<u>Ingalls Creek (45.0273) - Upstream of Cascade Creek</u>	<u>July 16 - February 28</u>	X	=
<u>Negro Creek (45.0323) - Mouth to falls at stream mile 2.9</u>	<u>Submit Application</u>	=	=

<u>Washington Counties and State Waters</u> <u>Water Resource Inventory Area (WRIA) in parentheses</u>	<u>Mineral Prospecting Is Allowed Only Between These Dates</u>	<u>State Waters (and tributaries, unless otherwise indicated) in Which You May Use Mineral Prospecting Equipment With a Four Inch Maximum Suction Intake Hose Diameter</u>	<u>State Waters (NOT including tributaries) in Which You May Use Mineral Prospecting Equipment With a Five Inch Maximum Suction Intake Hose Diameter</u>
<u>Negro Creek (45.0323) - Upstream of falls at stream mile 2.9</u>	<u>July 16 - February 28</u>	X	=
<u>Ruby Creek (45.0318)</u>	<u>July 16 - February 28</u>	X	=
<u>Tronson Creek (45.0346)</u>	<u>August 1 - February 28</u>	X	=
<u>Scotty Creek (45.0376)</u>	<u>August 1 - February 28</u>	X	=
<u>Shaser Creek (45.0365)</u>	<u>August 1 - February 28</u>	X	=
<u>Clallam County</u>	<u>July 16 - September 15</u>	X	=
<u>Clallam River (19.0129)</u>	<u>August 1 - August 15</u>	X	=
<u>Dungeness River (18.0018)</u>	<u>Submit Application</u>	=	=
<u>Independent Creek (18.MISC)</u>	<u>August 1 - August 31</u>	X	=
<u>Elwha River (18.0272)</u>	<u>August 1 - August 15</u>	X	X
<u>Hoko River (19.0148)</u>	<u>August 1 - September 15</u>	X	=
<u>Jimmycomelately Creek (17.0285)</u>	<u>August 1 - August 31</u>	X	=
<u>Lake Ozette (20.0046)</u>	<u>Submit Application</u>	=	=
<u>Little Quilcene River (17.0076)</u>	<u>July 16 - August 31</u>	X	=
<u>Lake Ozette tributaries</u>	<u>July 16 - September 15</u>	X	=
<u>Lyre River (19.0031)</u>	<u>August 1 - September 15</u>	X	=
<u>McDonald Creek (18.0160)</u>	<u>August 1 - September 15</u>	X	=
<u>Morse Creek (18.0185)</u>	<u>August 1 - August 15</u>	X	=
<u>Ozette River (20.0046)</u>	<u>July 16 - September 15</u>	X	=
<u>Pysht River (19.0113)</u>	<u>August 1 - September 15</u>	X	=
<u>Quillayute River (20.0096, 20.0162, 20.0175)</u>	<u>August 1 - August 15</u>	X	X
<u>Bogachiel River (20.0162)</u>	<u>Submit Application</u>	=	=
<u>Calawah River (20.0175)</u>	<u>August 1 - August 15</u>	X	X
<u>Salmon Creek (17.0245)</u>	<u>July 16 - August 31</u>	X	=
<u>Sekiu River (19.0203)</u>	<u>August 1 - September 15</u>	X	=
<u>Snow Creek (17.0219)</u>	<u>July 16 - August 31</u>	X	=
<u>Sol Duc River (20.0096)</u>	<u>Submit Application</u>	=	=
<u>Lake Pleasant (20.0313)</u>	<u>Submit Application</u>	=	=
<u>Lake Pleasant tributaries</u>	<u>July 16 - September 15</u>	X	=
<u>Sooes River (20.0015)</u>	<u>July 16 - September 15</u>	X	=
<u>Clark County</u>	<u>July 16 - September 30</u>	=	=
<u>Columbia River</u>	<u>See below</u>	=	=
<u>Lacamas Creek (28.0160) - Mouth to dam</u>	<u>August 1 - August 31</u>	X	=
<u>Lacamas Creek (28.0160) - Upstream of dam</u>	<u>August 1 - September 30</u>	X	=
<u>Lewis River (27.0168)</u>	<u>August 1 - August 15</u>	X	X
<u>East Fork Lewis River (27.0173) - Mouth to Lucia Falls</u>	<u>August 1 - August 15</u>	X	X
<u>East Fork Lewis River (27.0173) - Lucia Falls to Sunset Falls</u>	<u>August 1 - February 28</u>	X	X

<u>Washington Counties and State Waters</u> <u>Water Resource Inventory Area (WRIA) in parentheses</u>	<u>Mineral Prospecting Is Allowed Only Between These Dates</u>	<u>State Waters (and tributaries, unless otherwise indicated) in Which You May Use Mineral Prospecting Equipment With a Four Inch Maximum Suction Intake Hose Diameter</u>	<u>State Waters (NOT including tributaries) in Which You May Use Mineral Prospecting Equipment With a Five Inch Maximum Suction Intake Hose Diameter</u>
<u>East Fork Lewis River (27.0173) - Upstream of Sunset Falls</u>	<u>August 1 - February 28</u>	X	=
<u>Lake River (28.0020)</u>	<u>January 1 - December 31</u>	X	X
<u>Burnt Bridge Creek (28.0143)</u>	<u>August 1 - August 31</u>	X	=
<u>Salmon Creek (28.0059)</u>	<u>August 1 - August 31</u>	X	=
<u>Whipple Creek (28.0038)</u>	<u>August 1 - September 30</u>	X	=
<u>North Fork Lewis River (27.0334) - Confluence of East Fork to Merwin Dam</u>	<u>August 1 - August 15</u>	X	X
<u>Cedar Creek (27.0339)</u>	<u>August 1 - September 15</u>	X	=
<u>North Fork Lewis River (27.0334) - Merwin Dam to Lower Falls</u>	<u>July 16 - August 15</u>	X	X
<u>Canyon Creek (27.0442)</u>	<u>July 16 - February 28</u>	X	=
<u>North Fork Lewis River (27.0168) - Upstream of Lower Falls</u>	<u>July 16 - August 15</u>	X	X
<u>Washougal River (28.0159) - Mouth to Dougan Creek</u>	<u>August 1 - August 31</u>	X	X
<u>Washougal River (28.0159) - Upstream of Dougan Creek</u>	<u>August 1 - August 31</u>	X	=
<u>Columbia County</u>	<u>July 16 - September 30</u>	X	=
<u>Touchet River (32.0097)</u>	<u>August 1 - August 15</u>	X	X
<u>Grande Ronde River tributaries (35.2192)</u>	<u>July 16 - August 15</u>	X	=
<u>North Fork Touchet/Wolf Fork (32.0761)</u>	<u>Submit Application</u>	=	=
<u>South Fork Touchet (32.0708)</u>	<u>Submit Application</u>	=	=
<u>Tucannon River (35.0009)</u>	<u>July 16 - August 15</u>	X	X
<u>Walla Walla River (32.0008) - Mouth to Oregon State line</u>	<u>July 16 - September 15</u>	X	X
<u>Mill Creek (32.1436) - Mouth to Oregon State line</u>	<u>August 1 - August 15</u>	X	=
<u>Cowlitz County</u>	<u>July 16 - September 30</u>	X	=
<u>Chehalis River (22.0190/23.0190) - South Fork Chehalis River - Mouth to Fisk Falls</u>	<u>August 1 - August 31</u>	X	X
<u>Chehalis River (22.0190/23.0190) - South Fork Chehalis River - Upstream of Fisk Falls</u>	<u>August 1 - August 31</u>	X	=
<u>Columbia River</u>	<u>See below</u>	=	=
<u>Abernathy Creek (25.0297)</u>	<u>July 16 - September 15</u>	X	=
<u>Burke Creek (27.0148)</u>	<u>August 1 - August 31</u>	X	=
<u>Burris Creek (27.0151)</u>	<u>August 1 - August 31</u>	X	=
<u>Bybee Creek (27.0142)</u>	<u>August 1 - August 31</u>	X	=
<u>Canyon Creek (27.0147)</u>	<u>August 1 - August 31</u>	X	=

<u>Washington Counties and State Waters</u> <u>Water Resource Inventory Area (WRIA) in parentheses</u>	<u>Mineral Prospecting Is Allowed Only Between These Dates</u>	<u>State Waters (and tributaries, unless otherwise indicated) in Which You May Use Mineral Prospecting Equipment With a Four Inch Maximum Suction Intake Hose Diameter</u>	<u>State Waters (NOT including tributaries) in Which You May Use Mineral Prospecting Equipment With a Five Inch Maximum Suction Intake Hose Diameter</u>
<u>Coal Creek (25.0340)</u>	<u>July 16 - September 15</u>	<u>X</u>	<u>=</u>
<u>Clark Creek (25.0371)</u>	<u>August 1 - August 31</u>	<u>X</u>	<u>=</u>
<u>Cowlitz River (26.0002) - Mouth to barrier dam at river mile 49.5</u>	<u>July 16 - August 15</u>	<u>X</u>	<u>X</u>
<u>Coweeman River (26.0003) - Mouth to Baird Creek</u>	<u>August 1 - August 31</u>	<u>X</u>	<u>X</u>
<u>Coweeman River (26.0003) - Upstream of Baird Creek</u>	<u>August 1 - August 31</u>	<u>X</u>	<u>=</u>
<u>Cowlitz River (26.0002) - Tributaries below barrier dam to mouth</u>	<u>July 16 - September 30</u>	<u>X</u>	<u>=</u>
<u>Owl Creek (26.1441)</u>	<u>July 16 - September 15</u>	<u>X</u>	<u>=</u>
<u>Toutle River (26.0227)</u>	<u>July 16 - August 15</u>	<u>X</u>	<u>X</u>
<u>North Fork Toutle River (26.0314) - Mouth to Debris Dam</u>	<u>July 16 - August 15</u>	<u>X</u>	<u>X</u>
<u>North Fork Toutle River (26.0314) - Upstream of Debris Dam</u>	<u>July 16 - August 15</u>	<u>X</u>	<u>=</u>
<u>Green River (26.0323) - Mouth to Shultz Creek</u>	<u>July 16 - September 30</u>	<u>X</u>	<u>X</u>
<u>Green River (26.0323) - Upstream of Shultz Creek</u>	<u>July 16 - September 30</u>	<u>X</u>	<u>=</u>
<u>South Fork Toutle (26.0248) - Mouth to Bear Creek</u>	<u>July 16 - September 15</u>	<u>X</u>	<u>X</u>
<u>South Fork Toutle (26.0248) - Upstream of Bear Creek</u>	<u>July 16 - September 15</u>	<u>X</u>	<u>=</u>
<u>Tributaries to Silver Lake</u>	<u>July 16 - September 30</u>	<u>X</u>	<u>=</u>
<u>Germany Creek (25.0313)</u>	<u>July 16 - September 15</u>	<u>X</u>	<u>=</u>
<u>Kalama River (27.0002) - Mouth to Kalama Falls</u>	<u>August 1 - August 15</u>	<u>X</u>	<u>X</u>
<u>Kalama River (27.0002) - Upstream of Kalama Falls</u>	<u>August 1 - August 15</u>	<u>X</u>	<u>=</u>
<u>Lewis River (27.0168) - Mouth to East Fork Lewis River</u>	<u>August 1 - August 15</u>	<u>X</u>	<u>X</u>
<u>North Fork Lewis River (27.0334) - Confluence of East Fork to Merwin Dam</u>	<u>August 1 - August 15</u>	<u>X</u>	<u>X</u>
<u>North Fork Lewis River (27.0334) - Merwin Dam to Lower Falls</u>	<u>July 16 - August 15</u>	<u>X</u>	<u>X</u>
<u>Mill Creek (25.0284)</u>	<u>July 16 - September 15</u>	<u>X</u>	<u>=</u>
<u>Schoolhouse Creek (27.0139)</u>	<u>August 1 - August 31</u>	<u>X</u>	<u>=</u>
<u>Douglas County</u>	<u>July 1 - September 30</u>	<u>X</u>	<u>=</u>
<u>Columbia River</u>	<u>See below</u>	<u>=</u>	<u>=</u>
<u>Douglas Creek Canyon (44.0146)</u>	<u>May 16 - January 31</u>	<u>X</u>	<u>=</u>
<u>Foster Creek (50.0065)</u>	<u>August 1 - April 15</u>	<u>X</u>	<u>=</u>
<u>McCarteney Creek (44.0002)</u>	<u>July 1 - February 28</u>	<u>X</u>	<u>=</u>

<u>Washington Counties and State Waters</u> <u>Water Resource Inventory Area (WRIA) in parentheses</u>	<u>Mineral Prospecting Is Allowed Only Between These Dates</u>	<u>State Waters (and tributaries, unless otherwise indicated) in Which You May Use Mineral Prospecting Equipment With a Four Inch Maximum Suction Intake Hose Diameter</u>	<u>State Waters (NOT including tributaries) in Which You May Use Mineral Prospecting Equipment With a Five Inch Maximum Suction Intake Hose Diameter</u>
<u>Pine/Corbaley Canyon Creek (44.0779)</u>	<u>September 16 - April 15</u>	X	=
<u>Rock Island Creek (44.0630)</u>	<u>July 1 - September 30</u>	X	=
<u>Ferry County</u>	<u>July 1 - August 31</u>	X	=
<u>Columbia River</u>	<u>See below</u>	=	=
<u>Kettle River (60.0002)</u>	<u>June 16 - August 31</u>	X	X
<u>Boulder Creek (60.0130) - Mouth to Hodgson Road Bridge</u>	<u>Submit Application</u>	=	=
<u>Boulder Creek (60.0130) - Upstream of Hodgson Road Bridge</u>	<u>June 16 - February 28</u>	X	=
<u>Deadman Creek (60.0008) - Mouth to SR395 Crossing</u>	<u>Submit Application</u>	=	=
<u>Deadman Creek (60.0008) - Upstream of SR395</u>	<u>June 16 - February 28</u>	X	=
<u>Goosmus Creek (60.0254)</u>	<u>June 16 - February 28</u>	X	=
<u>Toroda Creek (60.0410)</u>	<u>July 1 - September 30</u>	X	=
<u>San Poil River (52.0004)</u>	<u>June 16 - September 30</u>	X	X
<u>Granite Creek (52.0099) - Mouth to Powerhouse Dam</u>	<u>June 16 - September 30</u>	X	=
<u>Granite Creek (52.0099) - Upstream of Powerhouse Dam</u>	<u>June 16 - February 28</u>	X	=
<u>West Fork San Poil River (52.0192) - Mouth to Deep Creek</u>	<u>June 16 - September 30</u>	X	X
<u>West Fork San Poil River (52.0192) - Upstream of Deep Creek</u>	<u>June 16 - September 30</u>	X	=
<u>Gold Creek (52.0197)</u>	<u>June 16 - February 28</u>	X	=
<u>Franklin County</u>	<u>June 1 - September 30</u>	X	=
<u>Columbia River</u>	<u>See below</u>	=	=
<u>Snake River</u>	<u>See below</u>	=	=
<u>Palouse River (34.0003)</u>	<u>July 16 - February 28</u>	X	X
<u>North bank tributaries of the lower Snake River between Palouse River and the mouth of the Snake River</u>	<u>June 16 - October 31</u>	X	=
<u>Garfield County</u>	<u>July 16 - September 30</u>	X	=
<u>Snake River (35.0003)</u>	<u>See below</u>	=	=
<u>Alpowa Creek (35.1440)</u>	<u>July 16 - December 15</u>	X	=
<u>Asotin Creek (35.1716)</u>	<u>July 16 - August 15</u>	X	=
<u>Deadman Creek (35.0688)</u>	<u>July 16 - December 15</u>	X	=
<u>Grande Ronde River tributaries (35.2192)</u>	<u>July 16 - August 15</u>	X	=
<u>Meadow Creek (35.0689)</u>	<u>July 16 - December 15</u>	X	=

<u>Washington Counties and State Waters</u> <u>Water Resource Inventory Area (WRIA) in parentheses</u>	<u>Mineral Prospecting Is Allowed Only Between These Dates</u>	<u>State Waters (and tributaries, unless otherwise indicated) in Which You May Use Mineral Prospecting Equipment With a Four Inch Maximum Suction Intake Hose Diameter</u>	<u>State Waters (NOT including tributaries) in Which You May Use Mineral Prospecting Equipment With a Five Inch Maximum Suction Intake Hose Diameter</u>
<u>Tucannon River (35.0009) - Mouth to Panjab Creek</u>	<u>July 16 - August 31</u>	X	X
<u>Tucannon River (35.0009) - Upstream of Panjab Creek</u>	<u>July 16 - August 31</u>	X	=
<u>Pataha Creek (35.0123) - Mouth to Pataha Creek</u>	<u>January 1 - December 31</u>	X	=
<u>Pataha Creek (35.0123) - Upstream of Pataha Creek</u>	<u>July 16 - December 31</u>	X	=
<u>Grant County</u>	<u>July 1 - October 31</u>	X	=
<u>Columbia River</u>	<u>See below</u>	=	=
<u>Crab Creek (41.0002)</u>	<u>July 16 - September 15</u>	X	X
<u>Grays Harbor County</u>	<u>July 16 - October 15</u>	X	=
<u>Chehalis River (22.0190/23.0190) - Mouth to Porter Creek</u>	<u>August 1 - August 31</u>	X	X
<u>Chehalis River (22.0190/23.0190) - Porter Creek to Fisk Falls</u>	<u>August 1 - August 15</u>	X	X
<u>Chehalis River (22.0190/23.0190) - Upstream of Fisk Falls</u>	<u>August 1 - August 15</u>	X	=
<u>Cedar Creek (23.0570)</u>	<u>August 1 - September 30</u>	X	=
<u>Cloquallum Creek (22.0501)</u>	<u>August 1 - September 30</u>	X	=
<u>Porter Creek (23.0543)</u>	<u>August 1 - September 30</u>	X	=
<u>Satsop River (22.0360)</u>	<u>August 1 - August 31</u>	X	X
<u>Wishkah River (22.0191)</u>	<u>August 1 - October 15</u>	X	X
<u>Wynoochee River (22.0260)</u>	<u>August 1 - September 30</u>	X	X
<u>Copalis River (21.0767)</u>	<u>August 1 - October 15</u>	X	X
<u>Elk River (22.1333)</u>	<u>July 1 - October 31</u>	X	X
<u>Hoquiam River (22.0137)</u>	<u>August 1 - October 15</u>	X	X
<u>Humtulpis River (22.0004) - Mouth to Forks</u>	<u>August 1 - September 30</u>	X	X
<u>Humtulpis River (22.0004) - Upstream of Forks</u>	<u>August 1 - September 30</u>	X	=
<u>Johns River (22.1270)</u>	<u>August 1 - September 30</u>	X	X
<u>Moclips River (21.0731)</u>	<u>August 1 - October 15</u>	X	X
<u>North River (24.0034)</u>	<u>August 1 - September 30</u>	X	X
<u>Queets River (21.0001)</u>	<u>August 1 - August 15</u>	X	X
<u>Quinalt River (21.0398)</u>	<u>August 1 - August 15</u>	X	X
<u>Raft River (21.0337)</u>	<u>August 1 - October 15</u>	X	X
<u>Island County</u>	<u>June 16 - October 15</u>	X	=
<u>Cavalero Creek (06.0065)</u>	<u>June 16 - December 15</u>	X	=
<u>Chapman Creek (06.0070)</u>	<u>June 16 - December 15</u>	X	=
<u>Crescent Creek (06.0002)</u>	<u>June 16 - December 15</u>	X	=
<u>Cultus Creek (06.0026)</u>	<u>June 16 - March 15</u>	X	=
<u>Deer Creek (06.0024)</u>	<u>June 16 - March 15</u>	X	=
<u>Dugwalla Creek (06.0001)</u>	<u>June 16 - March 15</u>	X	=

<u>Washington Counties and State Waters</u> <u>Water Resource Inventory Area (WRIA) in parentheses</u>	<u>Mineral Prospecting Is Allowed Only Between These Dates</u>	<u>State Waters (and tributaries, unless otherwise indicated) in Which You May Use Mineral Prospecting Equipment With a Four Inch Maximum Suction Intake Hose Diameter</u>	<u>State Waters (NOT including tributaries) in Which You May Use Mineral Prospecting Equipment With a Five Inch Maximum Suction Intake Hose Diameter</u>
<u>Glendale Creek (06.0025)</u>	<u>June 16 - December 15</u>	X	=
<u>Kristoferson Creek (06.0062-06.0063)</u>	<u>May 1 - December 15</u>	X	=
<u>Maxwelton Creek (06.0029)</u>	<u>June 16 - December 15</u>	X	=
<u>North Bluff Creek (06.0006)</u>	<u>June 16 - March 15</u>	X	=
<u>Old Clinton Creek (06.0023)</u>	<u>June 16 - March 15</u>	X	=
<u>Jefferson County</u>	<u>July 16 - October 31</u>	X	=
<u>Big Quilcene River (17.0012) - Mouth to Falls</u>	<u>July 16 - August 31</u>	X	X
<u>Big Quilcene River (17.0012) - Falls to Forks</u>	<u>August 1 - February 28</u>	X	X
<u>Big Quilcene River (17.0012) - Upstream of Forks</u>	<u>August 1 - February 28</u>	X	=
<u>Bogachiel River (20.0162)</u>	<u>Submit Application</u>	=	=
<u>Chimacum Creek (17.0203)</u>	<u>July 16 - September 15</u>	X	=
<u>Donovan Creek (17.0115)</u>	<u>July 1 - October 15</u>	X	=
<u>Dosewallips River (16.0442)</u>	<u>July 16 - August 15</u>	X	=
<u>Duckabush River (16.0351)</u>	<u>July 16 - August 15</u>	X	=
<u>Dungeness River (18.0018)</u>	<u>August 1 - August 15</u>	X	=
<u>Elwha River (18.0272)</u>	<u>August 1 - August 15</u>	X	X
<u>Goodman Creek (20.0406)</u>	<u>August 1 - September 15</u>	X	=
<u>Hoh River (20.0422)</u>	<u>August 1 - August 15</u>	X	X
<u>Little Quilcene River (17.0076)</u>	<u>July 16 - August 31</u>	X	=
<u>Queets River (21.0001)</u>	<u>August 1 - August 15</u>	X	X
<u>Matheny Creek (21.0165)</u>	<u>August 1 - August 15</u>	X	=
<u>Sams River (21.0205)</u>	<u>August 1 - August 15</u>	X	X
<u>Quinalt River (21.0398)</u>	<u>August 1 - August 15</u>	X	X
<u>Salmon Creek (17.0245)</u>	<u>July 16 - August 31</u>	X	=
<u>Skokomish River (16.0001)</u>	<u>August 1 - August 31</u>	X	X
<u>Snow Creek (17.0219)</u>	<u>July 16 - August 31</u>	X	=
<u>Tarboo Creek (17.0129)</u>	<u>August 1 - September 30</u>	X	=
<u>Thorndyke Creek (17.0170)</u>	<u>August 1 - October 15</u>	X	=
<u>King County</u>	<u>July 16 - September 30</u>	X	=
<u>Cedar River (08.0299) - Mouth to Forks</u>	<u>August 1 - August 31</u>	X	X
<u>Cedar River (08.0299) - Upstream of Forks</u>	<u>August 1 - August 31</u>	X	=
<u>Issaquah Creek (08.0178)</u>	<u>August 1 - August 31</u>	X	=
<u>Sammamish River (08.0057)</u>	<u>August 1 - August 31</u>	X	=
<u>Steele Creek (08.0379)</u>	<u>July 16 - February 28</u>	X	=
<u>Green River (Duwamish River) (09.0001) - Mouth to Sawmill Creek</u>	<u>August 1 - August 31</u>	X	X

<u>Washington Counties and State Waters</u> <u>Water Resource Inventory Area (WRIA) in parentheses</u>	<u>Mineral Prospecting Is Allowed Only Between These Dates</u>	<u>State Waters (and tributaries, unless otherwise indicated) in Which You May Use Mineral Prospecting Equipment With a Four Inch Maximum Suction Intake Hose Diameter</u>	<u>State Waters (NOT including tributaries) in Which You May Use Mineral Prospecting Equipment With a Five Inch Maximum Suction Intake Hose Diameter</u>
<u>Green River (Duwamish River) (09.0001) - Upstream of Sawmill Creek</u>	<u>August 1 - August 31</u>	X	=
<u>Lake Washington tributaries (08.LKWA)</u>	<u>August 1 - August 31</u>	X	=
<u>Snoqualmie River (07.0219) - Mouth to Snoqualmie Falls</u>	<u>August 1 - August 15</u>	X	X
<u>Snoqualmie River (07.0219) - Snoqualmie Falls to mouth of South Fork</u>	<u>July 16 - February 28</u>	X	X
<u>Patterson Creek (07.0376)</u>	<u>July 16 - September 30</u>	X	=
<u>Middle Fork Snoqualmie River (07.0219) - Mouth to Taylor Creek</u>	<u>July 16 - February 28</u>	X	X
<u>Middle Fork Snoqualmie River (07.0219) - Upstream of Taylor Creek</u>	<u>July 16 - February 28</u>	X	=
<u>Goat Creek (07.0754)</u>	<u>July 16 - February 28</u>	X	=
<u>North Fork Snoqualmie River (07.0527) - Mouth to Lennox Creek</u>	<u>July 16 - February 28</u>	X	X
<u>North Fork Snoqualmie River (07.0527) - Upstream of Lennox Creek</u>	<u>July 16 - February 28</u>	X	=
<u>Deep Creek (07.0562)</u>	<u>July 16 - February 28</u>	X	=
<u>Illinois Creek (07.0624)</u>	<u>July 16 - February 28</u>	X	=
<u>Lennox Creek (07.0596)</u>	<u>July 16 - February 28</u>	X	=
<u>Bear Creek (07.0606)</u>	<u>July 16 - February 28</u>	X	=
<u>Raging River (07.0384)</u>	<u>August 1 - September 15</u>	X	X
<u>South Fork Skykomish River (07.0012) - Mouth to Sunset Falls</u>	<u>August 1 - August 15</u>	X	X
<u>South Fork Skykomish River (07.0012) - Upstream of Sunset Falls</u>	<u>August 1 - August 15</u>	X	=
<u>Beckler River (07.1413) - Mouth to Boulder Creek</u>	<u>August 1 - August 15</u>	X	X
<u>Beckler River (07.1413) - Upstream of Boulder Creek</u>	<u>July 16 - February 28</u>	X	=
<u>Rapid River (07.1461) - Mouth to Meadow Creek</u>	<u>August 1 - August 31</u>	X	X
<u>Rapid River (07.1461) - Upstream of Meadow Creek</u>	<u>August 1 - February 28</u>	X	=
<u>Index Creek (07.1264) - Mouth to Mud Lake Creek</u>	<u>August 1 - August 31</u>	X	=
<u>Index Creek (07.1264) - Upstream of Mud Lake Creek including Salmon Creek</u>	<u>July 16 - February 28</u>	X	=

<u>Washington Counties and State Waters</u> <u>Water Resource Inventory Area (WRIA) in parentheses</u>	<u>Mineral Prospecting Is Allowed Only Between These Dates</u>	<u>State Waters (and tributaries, unless otherwise indicated) in Which You May Use Mineral Prospecting Equipment With a Four Inch Maximum Suction Intake Hose Diameter</u>	<u>State Waters (NOT including tributaries) in Which You May Use Mineral Prospecting Equipment With a Five Inch Maximum Suction Intake Hose Diameter</u>
<u>Miller River (07.1329) - Mouth to Forks</u>	<u>August 1 - August 15</u>	X	X
<u>Miller River (07.1329) - Upstream of Forks</u>	<u>August 1 - August 15</u>	X	=
<u>Coney Creek (07.1347)</u>	<u>July 16 - February 28</u>	X	=
<u>East Fork Miller River (07.1329) - Mouth to Great Falls Creek</u>	<u>July 16 - August 15</u>	X	=
<u>East Fork Miller River (07.1329) - Upstream of Great Falls Creek</u>	<u>July 16 - February 28</u>	X	=
<u>Foss River (07.1562) - Mouth to Forks</u>	<u>July 16 - August 31</u>	X	X
<u>East Fork Foss River (07.1562) - Mouth to Burn Creek</u>	<u>July 16 - August 15</u>	X	X
<u>East Fork Foss River (07.1562) - Upstream of Burn Creek</u>	<u>July 16 - February 28</u>	X	=
<u>West Fork Foss River (07.1573) - Mouth to falls at River Mile 2.0</u>	<u>July 16 - August 31</u>	X	=
<u>West Fork Foss River (07.1573) - Upstream of falls at River Mile 2.0</u>	<u>July 16 - February 28</u>	X	=
<u>West Fork Miller River (07.1335)</u>	<u>July 16 - February 28</u>	X	X
<u>Money Creek (07.1300) - Mouth to 0.5 mile upstream of Kimball Creek</u>	<u>August 1 - August 31</u>	X	=
<u>Money Creek (07.1300) - Upstream of 0.5 mile upstream of Kimball Creek</u>	<u>August 1 - February 28</u>	X	=
<u>Kimball Creek (07.1301)</u>	<u>August 1 - August 31</u>	X	=
<u>Tye River (07.0012) - Mouth to Alpine Falls</u>	<u>August 1 - August 31</u>	X	X
<u>Tye River (07.0012) - Upstream of Alpine Falls</u>	<u>July 16 - February 28</u>	X	=
<u>South Fork Snoqualmie River (07.0467)</u>	<u>July 16 - February 28</u>	X	X
<u>Denny Creek (07.0517)</u>	<u>July 16 - February 28</u>	X	=
<u>Tolt River (07.0291) - Mouth to forks</u>	<u>August 1 - August 31</u>	X	X
<u>North Fork Tolt River (07.0291) - Mouth to Yellow Creek</u>	<u>July 16 - September 15</u>	X	X
<u>North Fork Tolt River (07.0291) - Upstream of Yellow Creek</u>	<u>July 16 - February 28</u>	X	=
<u>South Fork Tolt River (07.0302) - Mouth to dam</u>	<u>July 16 - September 15</u>	X	X
<u>South Fork Tolt River (07.0302) - Upstream of Tolt Reservoir</u>	<u>July 16 - February 28</u>	X	=
<u>Yellow Creek (07.0337)</u>	<u>July 16 - February 28</u>	X	=

<u>Washington Counties and State Waters</u> <u>Water Resource Inventory Area (WRIA) in parentheses</u>	<u>Mineral Prospecting Is Allowed Only Between These Dates</u>	<u>State Waters (and tributaries, unless otherwise indicated) in Which You May Use Mineral Prospecting Equipment With a Four Inch Maximum Suction Intake Hose Diameter</u>	<u>State Waters (NOT including tributaries) in Which You May Use Mineral Prospecting Equipment With a Five Inch Maximum Suction Intake Hose Diameter</u>
<u>White River (10.0031)</u>	<u>July 16 - August 31</u>	<u>X</u>	<u>X</u>
<u>Greenwater River (10.0122)</u>	<u>July 16 - August 15</u>	<u>X</u>	<u>X</u>
<u>Kittitas County</u>	<u>July 1 - September 30</u>	<u>X</u>	<u>=</u>
<u>Brushy Creek (40.0612)</u>	<u>July 1 - February 28</u>	<u>X</u>	<u>=</u>
<u>Colockum Creek (40.0760)</u>	<u>July 1 - October 31</u>	<u>X</u>	<u>=</u>
<u>Quilomene Creek (40.0613)</u>	<u>July 1 - October 31</u>	<u>X</u>	<u>=</u>
<u>Stemilt Creek (40.0808) - Upstream of falls</u>	<u>July 1 - February 28</u>	<u>X</u>	<u>=</u>
<u>Tarpiscan Creek (40.0723)</u>	<u>July 1 - February 28</u>	<u>X</u>	<u>=</u>
<u>Tekiason Creek (40.0686)</u>	<u>July 1 - February 28</u>	<u>X</u>	<u>=</u>
<u>Whisky Dick Creek (40.0591)</u>	<u>July 1 - February 28</u>	<u>X</u>	<u>=</u>
<u>Yakima River (39.0002) - Roza Dam to Teanaway River</u>	<u>August 1 - August 31</u>	<u>X</u>	<u>X</u>
<u>Naches River (38.0003) - Tieton River to Bumping River</u>	<u>July 1 - August 15</u>	<u>X</u>	<u>X</u>
<u>Little Naches River (38.0852) - Mouth to Matthew Creek</u>	<u>July 16 - August 15</u>	<u>X</u>	<u>X</u>
<u>Little Naches River (38.0852) - Upstream of Matthew Creek</u>	<u>July 16 - August 15</u>	<u>X</u>	<u>=</u>
<u>Pileup Creek (38.0932)</u>	<u>July 16 - August 31</u>	<u>X</u>	<u>=</u>
<u>Gold Creek (38.MISC)</u>	<u>July 16 - February 28</u>	<u>X</u>	<u>=</u>
<u>Swauk Creek (39.1157)</u>	<u>July 16 - September 30</u>	<u>X</u>	<u>=</u>
<u>Baker Creek (39.1157)</u>	<u>July 16 - September 30</u>	<u>X</u>	<u>=</u>
<u>First Creek (39.1157)</u>	<u>July 16 - September 30</u>	<u>X</u>	<u>=</u>
<u>Iron Creek (39.1157)</u>	<u>July 16 - September 30</u>	<u>X</u>	<u>=</u>
<u>Williams Creek (39.1157)</u>	<u>July 16 - September 30</u>	<u>X</u>	<u>=</u>
<u>Boulder Creek (39.1157)</u>	<u>July 16 - February 28</u>	<u>X</u>	<u>=</u>
<u>Cougar Gulch (39.1157)</u>	<u>July 16 - February 28</u>	<u>X</u>	<u>=</u>
<u>Lion Gulch (39.1157)</u>	<u>July 16 - February 28</u>	<u>X</u>	<u>=</u>
<u>Yakima River (39.0002) - Teanaway River to Easton Dam</u>	<u>August 1 - August 31</u>	<u>X</u>	<u>X</u>
<u>Yakima River (39.0002) - Upstream of Easton Dam</u>	<u>August 1 - August 31</u>	<u>X</u>	<u>X</u>
<u>Cle Elum River (39.1434) - Mouth to Dam</u>	<u>July 16 - August 31</u>	<u>X</u>	<u>X</u>
<u>Cle Elum River (39.1434) - Upstream of Cle Elum Dam</u>	<u>July 1 - August 15</u>	<u>X</u>	<u>X</u>
<u>Big Boulder Creek (39.1434MISC)</u>	<u>August 1 - February 28</u>	<u>X</u>	<u>=</u>
<u>Camp Creek (39.1434MISC)</u>	<u>August 1 - February 28</u>	<u>X</u>	<u>=</u>
<u>Fortune Creek (39.1434MISC)</u>	<u>August 1 - August 15</u>	<u>X</u>	<u>=</u>
<u>South Fork Fortune Creek (39.1434MISC)</u>	<u>August 1 - February 28</u>	<u>X</u>	<u>=</u>
<u>Howson Creek (39.1434)</u>	<u>July 16 - February 28</u>	<u>X</u>	<u>=</u>

<u>Washington Counties and State Waters</u> <u>Water Resource Inventory Area (WRIA) in parentheses</u>	<u>Mineral Prospecting Is Allowed Only Between These Dates</u>	<u>State Waters (and tributaries, unless otherwise indicated) in Which You May Use Mineral Prospecting Equipment With a Four Inch Maximum Suction Intake Hose Diameter</u>	<u>State Waters (NOT including tributaries) in Which You May Use Mineral Prospecting Equipment With a Five Inch Maximum Suction Intake Hose Diameter</u>
<u>Little Salmon Le Sac Creek (39.1482)</u>	<u>August 1 - August 15</u>	X	=
<u>Paris Creek (39.1434MISC)</u>	<u>August 1 - February 28</u>	X	=
<u>Salmon Le Sac Creek (39.1520)</u>	<u>August 1 - February 28</u>	X	=
<u>Kachess River (39.1739) - Upstream of Lake Kachess</u>	<u>Submit Application</u>	=	=
<u>Kachess River (39.1739) - Below Dam</u>	<u>July 16 - August 15</u>	X	X
<u>Box Canyon Creek (39.1765)</u>	<u>Submit Application</u>	=	=
<u>Mineral Creek (39.1792)</u>	<u>August 1 - August 15</u>	X	=
<u>Lake Keechelus (39.1842) tributaries</u>	<u>July 16 - August 15</u>	X	=
<u>Gold Creek (Lake Keechelus) (39.1842)</u>	<u>Submit Application</u>	=	=
<u>Manastash Creek (39.0988)</u>	<u>July 16 - September 30</u>	X	=
<u>Naneum Creek (39.0821)</u>	<u>July 16 - September 30</u>	X	=
<u>Taneum Creek (39.1081) - Mouth to I-90</u>	<u>July 16 - August 31</u>	X	=
<u>Taneum Creek (39.1157) - Upstream of I-90</u>	<u>July 16 - September 30</u>	X	=
<u>Teanaway River (39.1236)</u>	<u>July 16 - August 31</u>	X	X
<u>NF Teanaway River (39.1260)</u>	<u>July 16 - August 15</u>	X	=
<u>Umtanum Creek (39.0553)</u>	<u>July 16 - September 30</u>	X	=
<u>Wenas Creek, Below Dam (39.0032)</u>	<u>July 16 - October 15</u>	X	=
<u>Wenas Creek, Upstream of Wenas Lake (39.0032)</u>	<u>July 16 - February 28</u>	X	=
<u>Other Yakima River tributaries not listed</u>	<u>July 16 - August 31</u>	X	=
<u>Kitsap County</u>	<u>July 16 - October 15</u>	X	=
<u>Anderson Creek (15.0211)</u>	<u>August 1 - November 15</u>	X	=
<u>Barker Creek (15.0255)</u>	<u>August 1 - September 30</u>	X	=
<u>Big Beef Creek (15.0389)</u>	<u>August 1 - August 15</u>	X	=
<u>Big Scandia Creek (15.0280)</u>	<u>August 1 - September 30</u>	X	=
<u>Blackjack Creek (15.0203)</u>	<u>August 1 - September 30</u>	X	=
<u>Burley Creek (15.0056)</u>	<u>August 1 - September 30</u>	X	=
<u>Chico Creek (15.0229)</u>	<u>August 1 - October 15</u>	X	=
<u>Clear Creek (15.0249)</u>	<u>August 1 - September 30</u>	X	=
<u>Curley Creek (15.0185)</u>	<u>August 1 - September 30</u>	X	=
<u>Dewatto River (15.0420)</u>	<u>August 1 - August 15</u>	X	=
<u>Dogfish Creek (15.0285)</u>	<u>August 1 - September 30</u>	X	=
<u>Gorst Creek (15.0216)</u>	<u>August 1 - August 31</u>	X	=
<u>Grovers Creek (15.0299)</u>	<u>August 1 - September 30</u>	X	=
<u>Johnson Creek (15.0387)</u>	<u>August 1 - October 31</u>	X	=

<u>Washington Counties and State Waters</u> <u>Water Resource Inventory Area (WRIA) in parentheses</u>	<u>Mineral Prospecting Is Allowed Only Between These Dates</u>	<u>State Waters (and tributaries, unless otherwise indicated) in Which You May Use Mineral Prospecting Equipment With a Four Inch Maximum Suction Intake Hose Diameter</u>	<u>State Waters (NOT including tributaries) in Which You May Use Mineral Prospecting Equipment With a Five Inch Maximum Suction Intake Hose Diameter</u>
<u>Ollala Creek (15.0107)</u>	<u>August 1 - September 30</u>	X	=
<u>Ross Creek (15.0209)</u>	<u>August 1 - November 15</u>	X	=
<u>Salmonberry Creek (15.0188)</u>	<u>August 1 - November 30</u>	X	=
<u>Seabeck Creek (15.0400)</u>	<u>August 1 - August 15</u>	X	=
<u>Steele Creek (15.0273)</u>	<u>August 1 - September 30</u>	X	=
<u>Tahuya River (15.0446)</u>	<u>August 1 - August 31</u>	X	X
<u>Union River (15.0503)</u>	<u>August 1 - August 31</u>	X	X
<u>Klickitat County</u>	<u>July 15 - September 30</u>	X	=
<u>Alder Creek (31.0459)</u>	<u>August 1 - September 30</u>	X	=
<u>Chapman Creek (31.0192)</u>	<u>August 1 - September 30</u>	X	=
<u>Glade Creek (31.0851)</u>	<u>August 1 - September 30</u>	X	=
<u>Juniper Canyon Creek (31.0378)</u>	<u>August 1 - September 30</u>	X	=
<u>Klickitat River (30.0002) - Mouth to Klickitat hatchery</u>	<u>Submit Application</u>	=	=
<u>Klickitat River (30.0002) - Upstream of Klickitat hatchery</u>	<u>Submit Application</u>	=	=
<u>Little White Salmon River (29.0131) - Mouth to Cabbage Creek</u>	<u>July 16 - January 31</u>	X	X
<u>Little White Salmon River (29.0131) - Upstream of Cabbage Creek</u>	<u>July 16 - January 31</u>	X	=
<u>Pine Creek (31.0354)</u>	<u>August 1 - September 30</u>	X	=
<u>Rock Creek (31.0014)</u>	<u>August 1 - September 30</u>	X	=
<u>Six Prong Creek (31.0465)</u>	<u>August 1 - September 30</u>	X	=
<u>White Salmon River (29.0160) - Mouth to Cascade Creek</u>	<u>July 16 - August 15</u>	X	X
<u>White Salmon River (29.0160) - Upstream of Cascade Creek</u>	<u>July 16 - August 15</u>	X	=
<u>Wood Gulch Creek (31.0263)</u>	<u>August 1 - September 30</u>	X	=
<u>Lewis County</u>	<u>August 1 - September 30</u>	X	=
<u>Chehalis River (22.0190/23.0190) - Mouth to South Fork Chehalis River</u>	<u>August 1 - August 15</u>	X	X
<u>Chehalis River (22.0190/23.0190) - Upstream of South Fork Chehalis River</u>	<u>August 1 - August 31</u>	X	X
<u>Newaukum River (23.0882) - Mouth to South Fork</u>	<u>August 1 - August 31</u>	X	X
<u>Newaukum River (23.0882) - Upstream of South Fork</u>	<u>August 1 - August 31</u>	X	=
<u>Skookumchuck River (23.0761)</u>	<u>August 1 - August 31</u>	X	X
<u>Cowlitz River (26.0002)</u>	<u>August 1 - August 15</u>	X	X

<u>Washington Counties and State Waters</u> <u>Water Resource Inventory Area (WRIA) in parentheses</u>	<u>Mineral Prospecting Is Allowed Only Between These Dates</u>	<u>State Waters (and tributaries, unless otherwise indicated) in Which You May Use Mineral Prospecting Equipment With a Four Inch Maximum Suction Intake Hose Diameter</u>	<u>State Waters (NOT including tributaries) in Which You May Use Mineral Prospecting Equipment With a Five Inch Maximum Suction Intake Hose Diameter</u>
<u>Cispus River (26.0668) - Mouth to Squaw Creek (26.1010)</u>	<u>August 1 - August 15</u>	X	X
<u>Cispus River (26.0668) - Squaw Creek to Chambers Creek</u>	<u>July 16 - February 28</u>	X	X
<u>Cispus River (26.0668) - Upstream of Chambers Creek</u>	<u>July 16 - February 28</u>	X	=
<u>Yellowjacket Creek (26.0757)</u>	<u>August 1 - August 15</u>	X	=
<u>McCoy Creek (26.0766) - Mouth to lower falls</u>	<u>August 1 - August 15</u>	X	=
<u>McCoy Creek (26.0766) - Upstream of lower falls</u>	<u>July 16 - February 28</u>	X	=
<u>Walupt Creek (26.1010)</u>	<u>Submit Application</u>	=	=
<u>Packwood Lake Tributaries</u>	<u>August 16 - September 15</u>	X	=
<u>Tilton River (26.0560) - Mouth to North Fork</u>	<u>August 1 - September 30</u>	X	X
<u>Tilton River (26.0560) - Upstream of North Fork</u>	<u>August 1 - September 30</u>	X	=
<u>Toutle River (26.0227)</u>	<u>August 1 - August 31</u>	X	X
<u>North Fork Toutle River (26.0314)</u>	<u>July 16 - August 15</u>	X	X
<u>Green River (26.0323)</u>	<u>July 16 - September 30</u>	X	X
<u>Deschutes River (13.0028)</u>	<u>July 16 - August 31</u>	X	X
<u>Little Deschutes River (13.0110)</u>	<u>July 16 - February 28</u>	X	=
<u>Nisqually River (11.0008) - Upstream of Alder Lake</u>	<u>July 16 - September 30</u>	X	X
<u>Lincoln County</u>	<u>June 16 - February 28</u>	X	=
<u>Columbia River</u>	<u>See below</u>	=	=
<u>Hawk Creek (53.0101) - Mouth to falls</u>	<u>June 16 - August 31</u>	X	=
<u>Hawk Creek (53.0101) - Upstream of falls</u>	<u>June 16 - February 28</u>	X	=
<u>Upper Crab Creek (42.0001)</u>	<u>June 16 - February 28</u>	X	=
<u>Wilson Creek (43.0020)</u>	<u>June 16 - February 28</u>	X	=
<u>Mason County</u>	<u>August 1 - October 15</u>	X	=
<u>Cloquallum Creek (22.0501)</u>	<u>August 1 - September 30</u>	X	=
<u>Coulter Creek (15.0002)</u>	<u>August 1 - August 31</u>	X	=
<u>Dewatto River (15.0420)</u>	<u>August 1 - August 31</u>	X	=
<u>Goldsborough Creek (14.0035)</u>	<u>August 1 - October 15</u>	X	=
<u>John Creek (16.0253)</u>	<u>August 1 - August 31</u>	X	=
<u>Hamma Hamma River (16.0251) - Mouth to falls</u>	<u>August 1 - August 31</u>	X	=
<u>Johns Creek (14.0049)</u>	<u>August 1 - August 15</u>	X	=
<u>Lilliwaup River (16.0230) - Mouth to falls</u>	<u>August 1 - August 31</u>	X	X

<u>Washington Counties and State Waters</u> <u>Water Resource Inventory Area (WRIA) in parentheses</u>	<u>Mineral Prospecting Is Allowed Only Between These Dates</u>	<u>State Waters (and tributaries, unless otherwise indicated) in Which You May Use Mineral Prospecting Equipment With a Four Inch Maximum Suction Intake Hose Diameter</u>	<u>State Waters (NOT including tributaries) in Which You May Use Mineral Prospecting Equipment With a Five Inch Maximum Suction Intake Hose Diameter</u>
<u>Lilliwaup River (16.0230) - Upstream of falls</u>	<u>August 1 - February 28</u>	X	=
<u>Mill Creek (14.0029)</u>	<u>August 1 - August 15</u>	X	=
<u>Satsop River (22.0360)</u>	<u>August 1 - August 31</u>	X	=
<u>Schaerer Creek (16.0326)</u>	<u>August 1 - August 31</u>	X	=
<u>Sherwood Creek (14.0094)</u>	<u>August 1 - August 15</u>	X	=
<u>Skokomish River (16.0001) - Mouth to Forks</u>	<u>August 1 - August 31</u>	X	X
<u>Skokomish River (16.0001) - Upstream of Forks</u>	<u>August 1 - August 31</u>	X	=
<u>Tahuya River (15.0446)</u>	<u>August 1 - August 31</u>	X	=
<u>Twanoh Creek (14.0134)</u>	<u>August 1 - October 31</u>	X	=
<u>Union River (15.0503)</u>	<u>August 1 - August 31</u>	X	X
<u>Okanogan County</u>	<u>July 1 - August 15</u>	X	=
<u>Aneas Creek (49.0243) - Mouth to falls</u>	<u>July 16 - August 31</u>	X	=
<u>Aneas Creek (49.0243) - Upstream of falls</u>	<u>July 1 - March 31</u>	X	=
<u>Chewiliken Creek (49.0232) - Mouth to falls</u>	<u>July 16 - August 31</u>	X	=
<u>Chewiliken Creek (49.0232) - Upstream of falls</u>	<u>July 1 - March 31</u>	X	=
<u>Chiliwist Creek (49.0034) - Mouth to falls</u>	<u>July 16 - August 31</u>	X	=
<u>Chiliwist Creek (49.0034) - Upstream of falls</u>	<u>July 1 - March 31</u>	X	=
<u>Foster Creek (50.0065)</u>	<u>July 1 - February 28</u>	X	=
<u>Methow River (48.0007) - Columbia confluence to Twisp River</u>	<u>July 1 - July 31</u>	X	X
<u>Methow River tributaries between Black Canyon Creek and Gold Creek</u>	<u>July 1 - February 28</u>	X	=
<u>Black Canyon Creek (48.0015) - Mouth to Left Fork</u>	<u>Submit Application</u>	=	=
<u>Black Canyon Creek (48.0015) - Upstream of Left Fork</u>	<u>July 1 - February 28</u>	X	=
<u>Gold Creek (48.0104) - Mouth to Foggy Dew Creek</u>	<u>Submit Application</u>	=	=
<u>Foggy Dew Creek (48.0153) - Mouth to Foggy Dew Falls</u>	<u>Submit Application</u>	=	=
<u>Foggy Dew Creek (48.0153) - Upstream of Foggy Dew Falls</u>	<u>July 1 - February 28</u>	X	=
<u>Middle Fork Gold Creek (48.0139)</u>	<u>July 1 - February 28</u>	X	=
<u>North Fork Gold Creek (48.0104)</u>	<u>Submit Application</u>	=	=

<u>Washington Counties and State Waters</u> <u>Water Resource Inventory Area (WRIA) in parentheses</u>	<u>Mineral Prospecting Is Allowed Only Between These Dates</u>	<u>State Waters (and tributaries, unless otherwise indicated) in Which You May Use Mineral Prospecting Equipment With a Four Inch Maximum Suction Intake Hose Diameter</u>	<u>State Waters (NOT including tributaries) in Which You May Use Mineral Prospecting Equipment With a Five Inch Maximum Suction Intake Hose Diameter</u>
<u>Crater Creek (48.0177) - Mouth to Martin Creek</u>	<u>Submit Application</u>	=	=
<u>Crater Creek (48.0177) - Upstream of Martin Creek</u>	<u>July 1 - February 28</u>	X	=
<u>Martin Creek (48.0177)</u>	<u>July 1 - February 28</u>	X	=
<u>South Fork Gold Creek (48.0105) - Mouth to Rainy Creek</u>	<u>Submit Application</u>	=	=
<u>South Fork Gold Creek (48.0105) - Upstream of Rainy Creek</u>	<u>July 1 - February 28</u>	X	=
<u>Rainy Creek (48.0105)</u>	<u>July 1 - February 28</u>	X	=
<u>McFarland Creek (48.0090) - Mouth to Vinegar Gulch</u>	<u>Submit Application</u>	=	=
<u>McFarland Creek (48.0090) - Upstream of Vinegar Gulch</u>	<u>July 1 - February 28</u>	X	=
<u>Methow River tributaries between Libby Creek and Beaver Creek</u>	<u>July 1 - February 28</u>	X	=
<u>Beaver Creek (48.0307)</u>	<u>Submit Application</u>	=	=
<u>Frazer Creek (48.0309)</u>	<u>July 1 - February 28</u>	X	=
<u>Lightning Creek (48.0361)</u>	<u>July 1 - February 28</u>	X	=
<u>Middle Fork Beaver Creek (48.0307)</u>	<u>July 1 - February 28</u>	X	=
<u>South Fork Beaver Creek (48.0342)</u>	<u>July 1 - February 28</u>	X	=
<u>Libby Creek (48.0203) - Mouth to Hornet Draw Creek</u>	<u>Submit Application</u>	=	=
<u>Libby Creek (48.0203) - Upstream of Hornet Draw</u>	<u>July 1 - February 28</u>	X	=
<u>Methow River (48.0007) - Twisp River to Goat Creek</u>	<u>July 1 - July 31</u>	X	X
<u>Methow River (48.0007) - Upstream of Goat Creek</u>	<u>July 1 - July 31</u>	X	=
<u>Chewuch River (48.0728) - Mouth to Meadow Creek</u>	<u>July 1 - July 31</u>	X	X
<u>Chewuch River (48.0728) - Upstream of Meadow Creek</u>	<u>July 1 - February 28</u>	X	=
<u>Early Winters Creek (48.1408) - Mouth to Silver Star Creek</u>	<u>Submit Application</u>	=	=
<u>Early Winters Creek (48.1408) - Upstream of Silver Star Creek</u>	<u>July 1 - February 28</u>	X	=
<u>Goat Creek (48.1364) - Mouth to 500' upstream of Montana Creek</u>	<u>Submit Application</u>	=	=
<u>Goat Creek (48.1364) - 500' Upstream of Montana Creek to Roundup Creek</u>	<u>July 1 - February 28</u>	X	=

<u>Washington Counties and State Waters</u> <u>Water Resource Inventory Area (WRIA) in parentheses</u>	<u>Mineral Prospecting Is Allowed Only Between These Dates</u>	<u>State Waters (and tributaries, unless otherwise indicated) in Which You May Use Mineral Prospecting Equipment With a Four Inch Maximum Suction Intake Hose Diameter</u>	<u>State Waters (NOT including tributaries) in Which You May Use Mineral Prospecting Equipment With a Five Inch Maximum Suction Intake Hose Diameter</u>
<u>Goat Creek (48.1364) - Upstream of Roundup Creek</u>	<u>Submit Application</u>	=	=
<u>Lost River (48.0592)</u>	<u>July 16 - August 15</u>	X	X
<u>Twisp River (48.0374)</u>	<u>July 1 - July 31</u>	X	X
<u>Buttermilk Creek (48.0466)</u>	<u>Submit Application</u>	=	=
<u>North Creek (48.0674)</u>	<u>Submit Application</u>	=	=
<u>North Fork Twisp River (48.0691)</u>	<u>July 1 - February 28</u>	X	=
<u>South Creek (48.0641) - Upstream of Louis Creek</u>	<u>July 1 - February 28</u>	X	=
<u>South Creek (48.0641) - Mouth to Louis Creek</u>	<u>Submit Application</u>	=	=
<u>South Fork Twisp River (48.0698)</u>	<u>July 1 - February 28</u>	X	=
<u>Wolf Creek (48.1300)</u>	<u>Submit Application</u>	=	=
<u>Myers Creek (60.0517)</u>	<u>July 1 - February 28</u>	X	=
<u>Bolster Creek (60.0517)</u>	<u>July 1 - February 28</u>	X	=
<u>Ethel Creek (60.0517)</u>	<u>July 1 - February 28</u>	X	=
<u>Gold Creek (60.0517)</u>	<u>July 1 - February 28</u>	X	=
<u>Mary Ann Creek (60.0517)</u>	<u>July 1 - February 28</u>	X	=
<u>North Fork Mary Ann Creek (60.0517)</u>	<u>July 1 - February 28</u>	X	=
<u>Okanogan River (49.0019) - Mouth to Zosel Dam</u>	<u>July 1 - August 31</u>	X	X
<u>Antoine Creek (49.0294) - Mouth to velocity gradient at river mile 1.0</u>	<u>July 1 - February 28</u>	X	=
<u>Antoine Creek (49.0294) - Upstream of falls</u>	<u>July 1 - March 31</u>	X	=
<u>Bonaparte Creek (49.0246) - Upstream of falls</u>	<u>July 1 - March 31</u>	X	=
<u>Bonaparte Creek (49.0246) - Mouth to Bonaparte Falls at river mile 1.0</u>	<u>July 1 - February 28</u>	X	=
<u>Loup Loup Creek (49.0048) - Mouth to Loup Loup Falls at river mile 2.4</u>	<u>July 1 - February 28</u>	X	=
<u>Loup Loup Creek (49.0048) - Upstream of Loup Loup Falls at river mile 2.4</u>	<u>July 1 - March 31</u>	X	=
<u>Mosquito Creek (49.0321) - Mouth to falls</u>	<u>July 1 - August 31</u>	X	=
<u>Mosquito Creek (49.0321) - Upstream of falls</u>	<u>July 1 - March 31</u>	X	=
<u>Nine Mile Creek (49.0516)</u>	<u>July 1 - February 28</u>	X	=
<u>Omak Creek (49.0138) - Mouth to Mission Falls at river mile 5.4</u>	<u>July 1 - February 28</u>	X	=

<u>Washington Counties and State Waters</u> <u>Water Resource Inventory Area (WRIA) in parentheses</u>	<u>Mineral Prospecting Is Allowed Only Between These Dates</u>	<u>State Waters (and tributaries, unless otherwise indicated) in Which You May Use Mineral Prospecting Equipment With a Four Inch Maximum Suction Intake Hose Diameter</u>	<u>State Waters (NOT including tributaries) in Which You May Use Mineral Prospecting Equipment With a Five Inch Maximum Suction Intake Hose Diameter</u>
<u>Omak Creek (49.0138) - Upstream of falls</u>	<u>July 1 - March 31</u>	X	=
<u>Salmon Creek (49.0079) - Mouth to diversion</u>	<u>July 1 - August 31</u>	X	=
<u>Salmon Creek (49.0079) - Upstream of diversion</u>	<u>July 1 - February 28</u>	X	=
<u>Similkameen River (49.0325) - Mouth to Enloe Dam</u>	<u>July 1 - August 31</u>	X	X
<u>Similkameen River (49.0325) - Upstream of Enloe Dam</u>	<u>July 1 - October 31</u>	X	X
<u>Sinlahekin Creek (49.0349) - Mouth to barrier dam at Connors Lake</u>	<u>July 1 - August 31</u>	X	=
<u>Cecile Creek (49.0447)</u>	<u>July 1 - February 28</u>	X	=
<u>Chopaka Creek (49.0357)</u>	<u>July 1 - February 28</u>	X	=
<u>Toats Coulee Creek (49.0368)</u>	<u>July 1 - February 28</u>	X	=
<u>Cougar Creek (49.0368)</u>	<u>July 1 - February 28</u>	X	=
<u>Siwash Creek (49.0284) - Falls to headwaters</u>	<u>July 1 - March 31</u>	X	=
<u>Siwash Creek (49.0284) - Mouth to falls at river mile 1.4</u>	<u>July 1 - February 28</u>	X	=
<u>Tonasket Creek (49.0501) - Mouth to Tonasket Falls at river mile 1.8</u>	<u>July 1 - February 28</u>	X	=
<u>Tonasket Creek (49.0501) - Upstream of Tonasket Falls at river mile 1.8</u>	<u>July 1 - March 31</u>	X	=
<u>Tunk Creek (49.0211) - Mouth to falls</u>	<u>July 1 - February 28</u>	X	=
<u>Tunk Creek (49.0211) - Upstream of falls</u>	<u>July 1 - March 31</u>	X	=
<u>San Poil River (52.0004)</u>	<u>June 16 - September 30</u>	X	X
<u>West Fork San Poil (52.0192)</u>	<u>June 16 - September 30</u>	X	X
<u>Gold Creek (52.0197)</u>	<u>June 16 - February 28</u>	X	=
<u>Toroda Creek (60.0410)</u>	<u>July 1 - September 30</u>	X	=
<u>Pacific County</u>	<u>August 1 - September 30</u>	X	=
<u>Bear River (24.0689)</u>	<u>August 1 - September 30</u>	X	X
<u>Bone River (24.0405)</u>	<u>August 1 - September 30</u>	X	=
<u>Chehalis River (22.0190/23.0190)</u>	<u>August 1 - August 15</u>	X	X
<u>Columbia River</u>	<u>See below</u>	=	=
<u>Chinook River (24.MISC)</u>	<u>August 1 - September 30</u>	X	X
<u>Grays River (25.0093)</u>	<u>July 16 - September 15</u>	X	X
<u>Naselle River (24.0543)</u>	<u>August 1 - September 15</u>	X	X
<u>Nemah River (24.0460)</u>	<u>August 1 - September 30</u>	X	X
<u>Niawiakum River (24.0417)</u>	<u>August 1 - September 30</u>	X	=

<u>Washington Counties and State Waters</u> <u>Water Resource Inventory Area (WRIA) in parentheses</u>	<u>Mineral Prospecting Is Allowed Only Between These Dates</u>	<u>State Waters (and tributaries, unless otherwise indicated) in Which You May Use Mineral Prospecting Equipment With a Four Inch Maximum Suction Intake Hose Diameter</u>	<u>State Waters (NOT including tributaries) in Which You May Use Mineral Prospecting Equipment With a Five Inch Maximum Suction Intake Hose Diameter</u>
<u>North River (24.0034)</u>	<u>August 1 - September 30</u>	<u>X</u>	<u>X</u>
<u>Palix River (24.0426)</u>	<u>August 1 - September 30</u>	<u>X</u>	<u>=</u>
<u>Willapa River (24.0251)</u>	<u>August 1 - September 30</u>	<u>X</u>	<u>X</u>
<u>Pend Oreille County</u>	<u>July 1 - August 31</u>	<u>X</u>	<u>=</u>
<u>Little Spokane River (55.0003)</u>	<u>August 1 - March 15</u>	<u>X</u>	<u>=</u>
<u>West Branch Little Spokane River (55.0439)</u>	<u>August 1 - March 15</u>	<u>X</u>	<u>=</u>
<u>Harvey Creek (62.0310) - Mouth to Rocky Fork of Harvey Creek</u>	<u>August 1 - August 31</u>	<u>X</u>	<u>=</u>
<u>Harvey Creek (62.0310) - Upstream of Rocky Fork of Harvey Creek</u>	<u>July 16 - February 28</u>	<u>X</u>	<u>=</u>
<u>Pend Oreille River (62.0002)</u>	<u>January 1 - December 31</u>	<u>X</u>	<u>X</u>
<u>Big Muddy Creek (62.0279)</u>	<u>August 1 - March 15</u>	<u>X</u>	<u>=</u>
<u>Bracket Creek (62.0815)</u>	<u>August 1 - March 15</u>	<u>X</u>	<u>=</u>
<u>Calispel Creek (62.0628)</u>	<u>August 1 - August 31</u>	<u>X</u>	<u>=</u>
<u>Exposure Creek (62.0261)</u>	<u>August 1 - August 31</u>	<u>X</u>	<u>=</u>
<u>Kent Creek (62.0819)</u>	<u>August 1 - March 15</u>	<u>X</u>	<u>=</u>
<u>Le Clerc Creek (62.0415)</u>	<u>August 1 - August 31</u>	<u>X</u>	<u>=</u>
<u>Lime Creek (62.0014)</u>	<u>August 1 - March 15</u>	<u>X</u>	<u>=</u>
<u>Lodge Creek (62.0859)</u>	<u>August 1 - August 31</u>	<u>X</u>	<u>=</u>
<u>Lost Creek (62.0322)</u>	<u>August 1 - March 15</u>	<u>X</u>	<u>=</u>
<u>Marshall Creek (62.0842)</u>	<u>August 1 - March 15</u>	<u>X</u>	<u>=</u>
<u>Pee Wee Creek (62.0007) - Mouth to falls</u>	<u>August 1 - August 31</u>	<u>X</u>	<u>=</u>
<u>Pee Wee Creek (62.0007) - Upstream of falls</u>	<u>August 1 - March 15</u>	<u>X</u>	<u>=</u>
<u>Renshaw Creek (62.0310)</u>	<u>August 1 - March 15</u>	<u>X</u>	<u>=</u>
<u>Sullivan (O'Sullivan) Creek (62.0074)</u>	<u>August 1 - August 31</u>	<u>X</u>	<u>=</u>
<u>North Fork Sullivan Creek (62.0075)</u>	<u>August 1 - August 31</u>	<u>X</u>	<u>=</u>
<u>Tributaries of Deep Creek in Pend Oreille County (61.0195)</u>	<u>July 16 - August 15</u>	<u>X</u>	<u>=</u>
<u>Currant Creek (61.0249)</u>	<u>July 16 - August 15</u>	<u>X</u>	<u>=</u>
<u>Meadow Creek (61.0351)</u>	<u>July 16 - August 15</u>	<u>X</u>	<u>=</u>
<u>Rocky Creek (61.0364)</u>	<u>July 16 - August 15</u>	<u>X</u>	<u>=</u>
<u>Silver Creek (61.0195)</u>	<u>July 16 - August 15</u>	<u>X</u>	<u>=</u>
<u>Smackout Creek (61.0226)</u>	<u>July 16 - August 15</u>	<u>X</u>	<u>=</u>
<u>Pierce County</u>	<u>July 16 - August 31</u>	<u>X</u>	<u>=</u>
<u>Chambers/Clover Creek Watershed (12.MISC)</u>	<u>July 16 - September 30</u>	<u>X</u>	<u>=</u>
<u>Flett Creek (12.0009)</u>	<u>July 16 - October 31</u>	<u>X</u>	<u>=</u>
<u>Leach Creek (12.0008)</u>	<u>July 16 - September 30</u>	<u>X</u>	<u>=</u>

<u>Washington Counties and State Waters</u> <u>Water Resource Inventory Area (WRIA) in parentheses</u>	<u>Mineral Prospecting Is Allowed Only Between These Dates</u>	<u>State Waters (and tributaries, unless otherwise indicated) in Which You May Use Mineral Prospecting Equipment With a Four Inch Maximum Suction Intake Hose Diameter</u>	<u>State Waters (NOT including tributaries) in Which You May Use Mineral Prospecting Equipment With a Five Inch Maximum Suction Intake Hose Diameter</u>
<u>Nisqually River (11.0008) - Mouth to Alder Lake</u>	<u>July 16 - August 31</u>	X	X
<u>Nisqually River (11.0008) - Upstream of Alder Lake</u>	<u>July 16 - September 30</u>	X	X
<u>Mashel River (11.0101) - Mouth to Busy Wild Creek</u>	<u>July 16 - September 30</u>	X	X
<u>Mashel River (11.0101) - Upstream of Busy Wild Creek</u>	<u>July 16 - September 30</u>	X	=
<u>Puyallup River (10.0021) - Mouth to PSE Electron Powerhouse Outfall</u>	<u>July 16 - August 31</u>	X	X
<u>Puyallup River (10.0021) - Upstream of PSE Electron Powerhouse Outfall</u>	<u>July 16 - August 15</u>	X	X
<u>Carbon River (10.0413)</u>	<u>July 16 - August 15</u>	X	X
<u>Cayada Creek (10.0525) - Mouth to falls about 800 feet upstream</u>	<u>July 16 - August 31</u>	X	=
<u>Cayada Creek (10.0525) - Upstream of the falls</u>	<u>January 1 - December 31</u>	X	=
<u>South Prairie Creek (10.0429) - Mouth to Dam at Buckley</u>	<u>July 16 - August 15</u>	X	=
<u>South Prairie Creek (10.0429) - Upstream of Dam at Buckley</u>	<u>July 16 - January 15</u>	X	=
<u>Voight Creek (10.0414) - Mouth to falls at River Mile 4.0</u>	<u>July 16 - August 31</u>	X	=
<u>Voight Creek (10.0414) - Upstream of falls River Mile 4.0</u>	<u>July 16 - February 28</u>	X	=
<u>White River (10.0031)</u>	<u>July 16 - August 15</u>	X	X
<u>Clearwater River (10.0080)</u>	<u>July 16 - August 31</u>	X	X
<u>Greenwater River (10.0122)</u>	<u>July 16 - August 15</u>	X	X
<u>Huckleberry Creek (10.0253)</u>	<u>July 16 - August 15</u>	X	=
<u>West Fork White River (10.0186)</u>	<u>July 16 - August 15</u>	X	X
<u>Sequalitchew Creek (12.0019)</u>	<u>July 16 - September 30</u>	X	=
<u>San Juan County</u>	<u>July 1 - August 31</u>	X	=
<u>Cascade Creek (02.0057), Orcas Island - Upstream of lower falls</u>	<u>July 1 - February 28</u>	X	=
<u>Cascade Creek (02.0057), Orcas Island, Buck Bay to falls located approximately 300 feet above mouth</u>	<u>July 1 - October 31</u>	X	=
<u>Doe Creek (02.MISC), San Juan Island, Westcott Bay to falls (approximately 250 feet from mouth)</u>	<u>June 16 - October 15</u>	X	=

<u>Washington Counties and State Waters</u> <u>Water Resource Inventory Area (WRIA) in parentheses</u>	<u>Mineral Prospecting Is Allowed Only Between These Dates</u>	<u>State Waters (and tributaries, unless otherwise indicated) in Which You May Use Mineral Prospecting Equipment With a Four Inch Maximum Suction Intake Hose Diameter</u>	<u>State Waters (NOT including tributaries) in Which You May Use Mineral Prospecting Equipment With a Five Inch Maximum Suction Intake Hose Diameter</u>
<u>False Bay Creek (02.MISC) - San Juan Island; Mouth to lake</u>	<u>July 1 - October 31</u>	X	=
<u>Glenwood Springs, Orcas Island; direct tributary to Eastsound Bay</u>	<u>July 1 - October 15</u>	X	=
<u>Moran Creek (02.MISC) - Orcas Island; from Cascade Lake delta upstream 1/4 mile</u>	<u>July 1 - October 15</u>	X	=
<u>Unnamed Creek (02.0041) - San Juan Island; Mouth to lake</u>	<u>July 1 - October 15</u>	X	=
<u>Skagit County</u>	<u>August 1 - September 15</u>	X	=
<u>Granite Creek (04.2313) - Upstream of East Creek</u>	<u>July 16 - February 28</u>	X	=
<u>North Fork Stillaguamish River (05.0135) - Mouth to Cascade Creek</u>	<u>August 1 - August 15</u>	X	X
<u>North Fork Stillaguamish River (05.0135) - Cascade Creek to Squire Creek</u>	<u>July 16 - February 28</u>	X	X
<u>North Fork Stillaguamish River (05.0135) - Upstream of Squire Creek</u>	<u>July 16 - February 28</u>	X	=
<u>Samish River (03.0005)</u>	<u>August 1 - September 15</u>	X	=
<u>Skagit River (03.0176/04.0176) - Mouth to Sauk River (04.0673)</u>	<u>August 1 - August 15</u>	X	X
<u>Skagit River (03.0176/04.0176) - Sauk River to Gorge Dam</u>	<u>August 1 - August 15</u>	X	X
<u>Baker River (04.0435) - Mouth to Baker Dam</u>	<u>August 1 - August 15</u>	X	X
<u>Cascade River (04.1411)</u>	<u>August 1 - August 15</u>	X	X
<u>Day Creek (03.1435)</u>	<u>July 16 - February 28</u>	X	=
<u>Lookout Creek (04.1447)</u>	<u>July 16 - February 28</u>	X	=
<u>Sibley Creek (04.1481)</u>	<u>July 16 - February 28</u>	X	=
<u>Day Creek (03.0299) - Mouth to Rocky Creek</u>	<u>Submit Application</u>	=	=
<u>Day Creek (03.0299) - Upstream of Rocky Creek</u>	<u>August 1 - February 28</u>	X	=
<u>Finney Creek (04.0392) - Mouth to Big Fir Creek</u>	<u>Submit Application</u>	=	=
<u>Finney Creek (04.0392) - Upstream of Big Fir Creek</u>	<u>July 16 - February 28</u>	X	=
<u>Illabot Creek (04.1346)</u>	<u>August 1 - August 15</u>	X	=
<u>Sauk River (04.0673) - Mouth to Forks</u>	<u>August 1 - August 15</u>	X	X
<u>Sauk River (04.0673) - Upstream of Forks</u>	<u>August 1 - August 15</u>	X	=

<u>Washington Counties and State Waters</u> <u>Water Resource Inventory Area (WRIA) in parentheses</u>	<u>Mineral Prospecting Is Allowed Only Between These Dates</u>	<u>State Waters (and tributaries, unless otherwise indicated) in Which You May Use Mineral Prospecting Equipment With a Four Inch Maximum Suction Intake Hose Diameter</u>	<u>State Waters (NOT including tributaries) in Which You May Use Mineral Prospecting Equipment With a Five Inch Maximum Suction Intake Hose Diameter</u>
<u>Suiattle River (04.0710)</u>	<u>August 1 - August 15</u>	<u>X</u>	<u>X</u>
<u>Wiseman Creek (03.0280) - Mouth to SR20</u>	<u>Submit Application</u>	<u>=</u>	<u>=</u>
<u>Wiseman Creek (03.0280) - Upstream of SR20</u>	<u>July 16 - February 28</u>	<u>X</u>	<u>=</u>
<u>South Fork Nooksack River (01.0246) - Mouth to falls at River Mile 30</u>	<u>August 1 - August 15</u>	<u>X</u>	<u>X</u>
<u>South Fork Nooksack River (01.0246) - Falls at River Mile 30 to Wanlick Creek</u>	<u>July 16 - August 15</u>	<u>X</u>	<u>X</u>
<u>South Fork Nooksack River (01.0246) - Upstream of Wanlick Creek</u>	<u>July 16 - August 15</u>	<u>X</u>	<u>=</u>
<u>Skamania County</u>	<u>July 15 - September 15</u>	<u>X</u>	<u>=</u>
<u>Columbia River</u>	<u>See below</u>	<u>=</u>	<u>=</u>
<u>Cispus River (26.0668)</u>	<u>August 1 - August 15</u>	<u>X</u>	<u>X</u>
<u>Cispus River (26.0668) tributaries located in Skamania County</u>	<u>August 1 - October 31</u>	<u>X</u>	<u>=</u>
<u>East Fork Lewis River (27.0173) - Lucia Falls to Sunset Falls</u>	<u>August 1 - February 28</u>	<u>X</u>	<u>X</u>
<u>East Fork Lewis River (27.0173) - Upstream of Sunset Falls</u>	<u>August 1 - February 28</u>	<u>X</u>	<u>=</u>
<u>Green River (26.0323) (Tributary of North Fork Toutle River)</u>	<u>July 16 - September 30</u>	<u>X</u>	<u>X</u>
<u>Hamilton Creek (28.0303)</u>	<u>August 1 - August 31</u>	<u>X</u>	<u>=</u>
<u>Hardy Creek (28.0303)</u>	<u>August 1 - August 31</u>	<u>X</u>	<u>=</u>
<u>Little White Salmon River (29.0131) - Mouth to Hatchery</u>	<u>July 16 - August 15</u>	<u>X</u>	<u>X</u>
<u>Little White Salmon River (29.0131) - Hatchery to Cabbage Creek</u>	<u>July 16 - January 31</u>	<u>X</u>	<u>X</u>
<u>Little White Salmon River (29.0131) - Upstream of Cabbage Creek</u>	<u>July 16 - January 31</u>	<u>X</u>	<u>=</u>
<u>North Fork Lewis River (27.0168) - Merwin Dam to Lower Falls</u>	<u>July 16 - August 15</u>	<u>X</u>	<u>X</u>
<u>Canyon Creek (27.0442)</u>	<u>July 16 - February 28</u>	<u>X</u>	<u>=</u>
<u>North Fork Lewis River (27.0168) - Upstream of Lower Falls</u>	<u>July 16 - February 28</u>	<u>X</u>	<u>X</u>
<u>Washougal River (28.0159) - Mouth to Stebbins Creek</u>	<u>August 1 - August 31</u>	<u>X</u>	<u>X</u>
<u>Washougal River (28.0159) - Upstream of Stebbins Creek</u>	<u>August 1 - August 31</u>	<u>X</u>	<u>=</u>

<u>Washington Counties and State Waters</u> <u>Water Resource Inventory Area (WRIA) in parentheses</u>	<u>Mineral Prospecting Is Allowed Only Between These Dates</u>	<u>State Waters (and tributaries, unless otherwise indicated) in Which You May Use Mineral Prospecting Equipment With a Four Inch Maximum Suction Intake Hose Diameter</u>	<u>State Waters (NOT including tributaries) in Which You May Use Mineral Prospecting Equipment With a Five Inch Maximum Suction Intake Hose Diameter</u>
<u>White Salmon River (29.0160) - Mouth to Cascade Creek</u>	<u>July 16 - August 15</u>	X	X
<u>White Salmon River (29.0160) - Upstream of Cascade Creek</u>	<u>July 16 - August 15</u>	X	=
<u>Wind River (29.0023)</u>	<u>August 1 - August 15</u>	X	X
<u>Woodward Creek (28.0298)</u>	<u>August 1 - August 31</u>	X	=
<u>Snohomish County</u>	<u>July 16 - September 15</u>	X	=
<u>Lake Washington tributaries</u>	<u>August 1 - August 15</u>	X	=
<u>Sauk River (04.0673) - Mouth to Forks</u>	<u>August 1 - August 15</u>	X	X
<u>Sauk River (04.0673) - Upstream of Forks</u>	<u>August 1 - August 15</u>	X	=
<u>Suiattle River (04.0710)</u>	<u>August 1 - August 15</u>	X	X
<u>Snohomish River (07.0012) - Mouth to Highway 9</u>	<u>August 1 - October 31</u>	X	X
<u>Snohomish River (07.0012) - Upstream of Highway 9</u>	<u>August 1 - August 15</u>	X	X
<u>Pilchuck River (07.0125) - Mouth to City of Snohomish diversion dam</u>	<u>August 1 - August 31</u>	X	X
<u>Pilchuck River (07.0125) - City of Snohomish diversion dam to Boulder Creek</u>	<u>August 1 - September 15</u>	X	X
<u>Pilchuck River (07.0125) - Upstream of Boulder Creek</u>	<u>August 1 - September 15</u>	X	=
<u>Skykomish River (07.0012) - Mouth to forks</u>	<u>August 1 - August 15</u>	X	X
<u>Deer Creek (05.0173) - Mouth to stream mile 0.5</u>	<u>August 1 - August 31</u>	X	=
<u>Deer Creek (05.0173) - Upstream of stream mile 0.5</u>	<u>August 1 - February 28</u>	X	=
<u>North Fork Skykomish River (07.0982) - Mouth to Bear Creek Falls</u>	<u>August 1 - August 31</u>	X	X
<u>North Fork Skykomish River (07.0982) - Bear Creek Falls to Deer Falls</u>	<u>August 1 - August 31</u>	X	X
<u>North Fork Skykomish River (07.0982) - Deer Falls to West Cady Creek</u>	<u>August 1 - February 28</u>	X	X
<u>North Fork Skykomish River (07.0982) - Upstream of West Cady Creek</u>	<u>August 1 - February 28</u>	X	=
<u>Howard Creek (07.1042)</u>	<u>July 16 - February 28</u>	X	=
<u>Silver Creek (07.1053) - Mouth to Lake Gulch</u>	<u>August 1 - August 31</u>	X	=

<u>Washington Counties and State Waters</u> <u>Water Resource Inventory Area (WRIA) in parentheses</u>	<u>Mineral Prospecting Is Allowed Only Between These Dates</u>	<u>State Waters (and tributaries, unless otherwise indicated) in Which You May Use Mineral Prospecting Equipment With a Four Inch Maximum Suction Intake Hose Diameter</u>	<u>State Waters (NOT including tributaries) in Which You May Use Mineral Prospecting Equipment With a Five Inch Maximum Suction Intake Hose Diameter</u>
<u>Silver Creek (07.1053) - Upstream of Lake Gulch</u>	<u>August 1 - February 28</u>	X	=
<u>Troublesome Creek (07.1085)</u>	<u>August 1 - February 28</u>	X	=
<u>West Fork Troublesome Creek (07.1092)</u>	<u>August 1 - August 31</u>	X	=
<u>South Fork Skykomish River (07.0012) - Mouth to Sunset Falls</u>	<u>August 1 - August 15</u>	X	X
<u>Beckler River (07.1413) - Mouth to Boulder Creek</u>	<u>August 1 - August 15</u>	X	X
<u>Beckler River (07.1413) - Upstream of Boulder Creek</u>	<u>July 16 - February 28</u>	X	=
<u>Rapid River (07.1461) - Mouth to Meadow Creek</u>	<u>August 1 - August 31</u>	X	X
<u>Rapid River (07.1461) - Upstream of Meadow Creek</u>	<u>August 1 - February 28</u>	X	X
<u>Sultan River (07.0881) - Mouth to Diversion Dam at river mile 9.4</u>	<u>August 1 - August 15</u>	X	X
<u>Sultan River (07.0881) - Diversion Dam to Elk Creek</u>	<u>July 16 - February 28</u>	X	X
<u>Sultan River (07.0881) - Upstream of Elk Creek</u>	<u>July 16 - February 28</u>	X	=
<u>Wallace River (07.0940) - Mouth to Wallace Falls</u>	<u>August 1 - August 31</u>	X	X
<u>Wallace River (07.0940) - Upstream of Wallace Falls</u>	<u>August 1 - February 28</u>	X	=
<u>Olney Creek (07.0946) - Mouth to Olney Falls</u>	<u>August 1 - August 31</u>	X	=
<u>Olney Creek (07.0946) - Upstream of Olney Falls</u>	<u>August 1 - February 28</u>	X	=
<u>Snoqualmie River Mouth to Falls (07.0219)</u>	<u>August 1 - August 15</u>	X	X
<u>All other Snohomish River tributaries</u>	<u>August 1 - August 31</u>	X	=
<u>Stillaguamish River (05.0001) - Mouth to forks</u>	<u>August 1 - August 31</u>	X	X
<u>North Fork Stillaguamish River (05.0135) - Mouth to Cascade Creek</u>	<u>August 1 - August 15</u>	X	X
<u>North Fork Stillaguamish River (05.0135) - Cascade Creek to Squire Creek</u>	<u>July 16 - February 28</u>	X	X
<u>North Fork Stillaguamish River (05.0135) - Upstream of Squire Creek</u>	<u>July 16 - February 28</u>	X	=
<u>South Fork Stillaguamish River (05.0001) - Mouth to Deer Creek</u>	<u>August 1 - August 15</u>	X	X

<u>Washington Counties and State Waters</u> <u>Water Resource Inventory Area (WRIA) in parentheses</u>	<u>Mineral Prospecting Is Allowed Only Between These Dates</u>	<u>State Waters (and tributaries, unless otherwise indicated) in Which You May Use Mineral Prospecting Equipment With a Four Inch Maximum Suction Intake Hose Diameter</u>	<u>State Waters (NOT including tributaries) in Which You May Use Mineral Prospecting Equipment With a Five Inch Maximum Suction Intake Hose Diameter</u>
<u>South Fork Stillaguamish River (05.0001) - Upstream of Deer Creek</u>	<u>August 1 - August 15</u>	X	=
<u>Spokane County</u>	<u>June 16 - August 31</u>	X	=
<u>Latah Creek (56.0003)</u>	<u>June 16 - August 31</u>	X	=
<u>Little Spokane River (55.0600) - Mouth to Deer Creek</u>	<u>June 16 - August 31</u>	X	X
<u>Little Spokane River (55.0600) - Upstream of Deer Creek</u>	<u>June 16 - August 31</u>	X	=
<u>Spokane River (57.0001)</u>	<u>June 16 - August 31</u>	X	X
<u>Stevens County</u>	<u>July 16 - August 31</u>	X	=
<u>Columbia River</u>	<u>See below</u>	=	=
<u>Big Sheep Creek (61.0150)</u>	<u>July 16 - August 15</u>	X	=
<u>Colville River (59.0002) - Mouth to the Falls</u>	<u>July 16 - September 30</u>	X	X
<u>Colville River (59.0002) - Upstream of the Falls</u>	<u>July 16 - September 30</u>	X	X
<u>Deep Creek (61.0195)</u>	<u>July 16 - August 15</u>	X	=
<u>Onion Creek (61.0098)</u>	<u>July 16 - August 15</u>	X	=
<u>Sheep Creek (59.0861)</u>	<u>July 16 - September 30</u>	X	=
<u>Lake Roosevelt tributaries from the mouth of the Spokane River to mouth of the Colville River</u>	<u>July 16 - February 28</u>	X	=
<u>Lake Roosevelt tributaries from the mouth of the Colville River north to the B.C. Border</u>	<u>July 16 - February 28</u>	X	=
<u>Tributaries of Little Spokane River (55.0600)</u>	<u>June 16 - August 31</u>	X	=
<u>Calispel Creek (62.0628)</u>	<u>August 1 - August 31</u>	X	=
<u>Other tributaries to the Pend Oreille River in Stevens County</u>	<u>July 1 - August 31</u>	X	=
<u>Thurston County</u>	<u>July 16 - September 15</u>	X	=
<u>Cedar Creek (23.0570)</u>	<u>August 1 - September 30</u>	X	=
<u>Chehalis River (22.0190/23.0190) - Upstream of Porter Creek</u>	<u>August 1 - August 15</u>	X	X
<u>Skookumchuck River (23.0761) - Mouth to Skookumchuck Reservoir</u>	<u>August 1 - August 31</u>	X	X
<u>Skookumchuck River (23.0761) - Upstream of Skookumchuck Reservoir</u>	<u>August 1 - August 31</u>	X	=
<u>Deschutes River (13.0028) - Mouth to Deschutes Falls</u>	<u>July 16 - August 31</u>	X	X
<u>Deschutes River (13.0028) - Upstream of Deschutes Falls</u>	<u>July 16 - August 31</u>	X	=

<u>Washington Counties and State Waters</u> <u>Water Resource Inventory Area (WRIA) in parentheses</u>	<u>Mineral Prospecting Is Allowed Only Between These Dates</u>	<u>State Waters (and tributaries, unless otherwise indicated) in Which You May Use Mineral Prospecting Equipment With a Four Inch Maximum Suction Intake Hose Diameter</u>	<u>State Waters (NOT including tributaries) in Which You May Use Mineral Prospecting Equipment With a Five Inch Maximum Suction Intake Hose Diameter</u>
<u>Ellis Creek (13.0022)</u>	<u>May 16 - September 30</u>	X	=
<u>Little Deschutes River (13.0110)</u>	<u>July 16 - February 28</u>	X	=
<u>McLane Creek (13.0138)</u>	<u>August 1 - October 31</u>	X	=
<u>Percival Creek (13.0029)</u>	<u>July 16 - August 31</u>	X	=
<u>Nisqually River (11.0008)</u>	<u>July 16 - August 31</u>	X	X
<u>Tributaries of Nisqually River (11.0008)</u>	<u>July 16 - August 31</u>	X	=
<u>Porter Creek (23.0543)</u>	<u>August 1 - September 30</u>	X	=
<u>Schneider Creek (14.0009)</u>	<u>August 1 - October 31</u>	X	=
<u>Waddell Creek (23.0677)</u>	<u>August 1 - September 30</u>	X	=
<u>Woodard Creek (13.0012)</u>	<u>July 16 - August 31</u>	X	=
<u>Woodland Creek (13.0006)</u>	<u>July 16 - September 30</u>	X	=
<u>Wahkiakum County</u>	<u>July 16 - September 15</u>	X	=
<u>Columbia River</u>	<u>See below</u>	=	=
<u>Abernathy Creek (25.0297)</u>	<u>July 16 - September 15</u>	X	=
<u>Deep River (25.0011)</u>	<u>July 16 - September 15</u>	X	X
<u>Elochoman River (25.0236)</u>	<u>July 16 - September 15</u>	X	X
<u>Grays River (25.0093)</u>	<u>July 16 - September 15</u>	X	X
<u>Mill Creek (25.0284)</u>	<u>July 16 - September 15</u>	X	=
<u>Naselle River (24.0543)</u>	<u>August 1 - September 15</u>	X	X
<u>Skamokowa Creek (25.0194)</u>	<u>July 16 - September 15</u>	X	=
<u>Walla Walla County</u>	<u>July 16 - September 30</u>	X	=
<u>Walla Walla River (32.0008) - Mouth to Oregon state line</u>	<u>July 16 - September 15</u>	X	X
<u>Mill Creek (32.1436) - Mouth to Oregon state line</u>	<u>August 1 - August 15</u>	X	=
<u>Touchet River (32.0097) - Mouth to Forks</u>	<u>August 1 - August 15</u>	X	X
<u>North Fork Touchet/Wolf Fork (32.0761)</u>	<u>Submit Application</u>	=	=
<u>South Fork Touchet (32.0708)</u>	<u>Submit Application</u>	=	=
<u>Whatcom County</u>	<u>July 16 - August 15</u>	X	=
<u>Damfino Creek (00.0032)</u>	<u>July 16 - August 31</u>	X	=
<u>Nooksack River (01.0120)</u>	<u>July 16 - August 15</u>	X	X
<u>Cascade Creek (02.0057) - Mouth to FR 37</u>	<u>Submit Application</u>	=	=
<u>Cascade Creek (02.0057) - Upstream of FR 37</u>	<u>July 16 - February 28</u>	X	=
<u>Middle Fork Nooksack River (01.0339) - Mouth to City of Bellingham Diversion Dam</u>	<u>July 16 - August 15</u>	X	X
<u>Middle Fork Nooksack River (01.0339) - Upstream of City of Bellingham Diversion Dam</u>	<u>Submit Application</u>	=	=

<u>Washington Counties and State Waters</u> <u>Water Resource Inventory Area (WRIA) in parentheses</u>	<u>Mineral Prospecting Is Allowed Only Between These Dates</u>	<u>State Waters (and tributaries, unless otherwise indicated) in Which You May Use Mineral Prospecting Equipment With a Four Inch Maximum Suction Intake Hose Diameter</u>	<u>State Waters (NOT including tributaries) in Which You May Use Mineral Prospecting Equipment With a Five Inch Maximum Suction Intake Hose Diameter</u>
<u>North Fork Nooksack River (01.0120) - Mouth to Nooksack Falls</u>	<u>July 16 - August 15</u>	X	X
<u>North Fork Nooksack River (01.0120) - Upstream of Nooksack Falls</u>	<u>Submit Application</u>	=	=
<u>Barometer Creek (01.0513)</u>	<u>July 16 - February 28</u>	X	=
<u>Ruth Creek (01.0531)</u>	<u>July 16 - February 28</u>	X	=
<u>Swamp Creek (01.0518)</u>	<u>July 16 - February 28</u>	X	=
<u>Wells Creek (02.0057)</u>	<u>Submit Application</u>	=	=
<u>Bar Creek (01.0500)</u>	<u>July 16 - February 28</u>	X	=
<u>South Fork Nooksack (01.0246) - Mouth to Wanlick Creek</u>	<u>August 1 - August 15</u>	X	X
<u>South Fork Nooksack (01.0246) - Upstream of Wanlick Creek</u>	<u>August 1 - August 15</u>	X	=
<u>Samish River (03.0005)</u>	<u>July 16 - August 15</u>	X	=
<u>Skagit River (03.0176) - Mouth to Sauk River</u>	<u>August 1 - August 15</u>	X	X
<u>Skagit River (03.0176) - Sauk River to Gorge Dam</u>	<u>August 1 - August 15</u>	X	X
<u>Skagit River (03.0176/04.0176) - Gorge Dam to Ross Dam</u>	<u>Submit Application</u>	=	=
<u>Baker River (04.0435) - Mouth to Baker Lake Dam (04.0435)</u>	<u>Submit Application</u>	=	=
<u>Baker River (04.0435) - Baker Lake to national park boundary</u>	<u>Submit Application</u>	=	=
<u>Boulder Creek (04.0499)</u>	<u>July 16 - February 28</u>	X	=
<u>Park Creek (04.0506) - Mouth to fish passage barrier at river mile 1.6</u>	<u>Submit Application</u>	=	=
<u>Park Creek (04.0506) - Upstream of river mile 1.6</u>	<u>July 16 - February 28</u>	X	=
<u>Swift Creek (04.0509) - Mouth to Rainbow Creek</u>	<u>Submit Application</u>	=	=
<u>Swift Creek (04.0509) - Upstream of Rainbow Creek</u>	<u>July 16 - February 28</u>	X	=
<u>Ross Lake (03.0176/04.0176) tributaries</u>	<u>Submit Application</u>	=	=
<u>Ruby Creek (04.2199)</u>	<u>Submit Application</u>	=	=
<u>Canyon Creek (04.2458) - Mouth to Barron Creek</u>	<u>Submit Application</u>	=	=
<u>Canyon Creek (04.2458) - Upstream of Barron Creek and tributaries</u>	<u>October 1 - February 28</u>	X	=
<u>Barron Creek (04.2591)</u>	<u>October 1 - February 28</u>	X	=

<u>Washington Counties and State Waters</u> <u>Water Resource Inventory Area (WRIA) in parentheses</u>	<u>Mineral Prospecting Is Allowed Only Between These Dates</u>	<u>State Waters (and tributaries, unless otherwise indicated) in Which You May Use Mineral Prospecting Equipment With a Four Inch Maximum Suction Intake Hose Diameter</u>	<u>State Waters (NOT including tributaries) in Which You May Use Mineral Prospecting Equipment With a Five Inch Maximum Suction Intake Hose Diameter</u>
<u>Boulder Creek (04.2478) - Mouth to 300 feet upstream</u>	<u>Submit Application</u>	=	=
<u>Boulder Creek (04.2478) - 300 feet upstream of mouth to headwaters</u>	<u>October 1 - February 28</u>	X	=
<u>Friday Creek (04.2549) - Mouth to 300 feet upstream</u>	<u>Submit Application</u>	=	=
<u>Friday Creek (04.2549) - 300 feet upstream of mouth to headwaters</u>	<u>October 1 - February 28</u>	X	=
<u>Holmes Creek (04.2473) - Mouth to 300 feet upstream</u>	<u>Submit Application</u>	=	=
<u>Holmes Creek (04.2473) - 300 feet upstream of mouth to headwaters</u>	<u>October 1 - February 28</u>	X	=
<u>Mill Creek (04.2504) - Mouth to 300 feet upstream</u>	<u>Submit Application</u>	=	=
<u>Mill Creek (04.2504) - 300 feet upstream of mouth to headwaters</u>	<u>October 1 - February 28</u>	X	=
<u>Nickol Creek (04.2476) - Mouth to 300 feet upstream</u>	<u>Submit Application</u>	=	=
<u>Nickol Creek (04.2476) - 300 feet upstream of mouth to headwaters</u>	<u>October 1 - February 28</u>	X	=
<u>North Fork Canyon Creek (04.2583) - Mouth to Elk Creek</u>	<u>Submit Application</u>	=	=
<u>Cascade Creek (05.2584)</u>	<u>October 1 - February 28</u>	X	=
<u>North Fork Canyon Creek (04.2583) - Upstream of Elk Creek</u>	<u>October 1 - February 28</u>	X	=
<u>Slate Creek (04.2557) - Mouth to falls at River Mile 0.6</u>	<u>Submit Application</u>	=	=
<u>Slate Creek (04.2557) - Upstream of falls at River Mile 0.6</u>	<u>October 1 - February 28</u>	X	=
<u>Granite Creek (04.2313) - Mouth to East Creek</u>	<u>Submit Application</u>	=	=
<u>Granite Creek (04.2313) - Upstream of East Creek and tributaries</u>	<u>October 1 - February 28</u>	X	=
<u>Saar Creek (00.0003)</u>	<u>August 1 - September 30</u>	X	=
<u>Silesia Creek (00.0042) - Canadian Border to Middle Fork</u>	<u>July 16 - August 15</u>	X	=
<u>Silesia Creek (00.0042) - Middle Fork to national park boundary</u>	<u>July 16 - February 28</u>	X	=
<u>Rapid Creek (00.0048)</u>	<u>July 16 - February 28</u>	X	=
<u>West Fork Silesia Creek (00.0044)</u>	<u>July 16 - February 28</u>	X	=
<u>Winchester Creek (00.0045)</u>	<u>July 16 - February 28</u>	X	=
<u>Whitman County</u>	<u>July 16 - December 15</u>	X	=
<u>Snake River (35.0002)</u>	<u>See below</u>	=	=
<u>Alkali Flats Creek (35.0570)</u>	<u>July 16 - December 15</u>	X	=

<u>Washington Counties and State Waters</u> <u>Water Resource Inventory Area (WRIA) in parentheses</u>	<u>Mineral Prospecting Is Allowed Only Between These Dates</u>	<u>State Waters (and tributaries, unless otherwise indicated) in Which You May Use Mineral Prospecting Equipment With a Four Inch Maximum Suction Intake Hose Diameter</u>	<u>State Waters (NOT including tributaries) in Which You May Use Mineral Prospecting Equipment With a Five Inch Maximum Suction Intake Hose Diameter</u>
<u>Almota Creek (35.1017)</u>	<u>July 16 - December 15</u>	X	=
<u>Little Almota Creek (35.1018)</u>	<u>July 16 - December 15</u>	X	=
<u>Palouse River (34.0003) - Mouth to Palouse Falls</u>	<u>July 16 - September 30</u>	X	X
<u>Palouse River (34.0003) - Upstream of Palouse Falls</u>	<u>July 16 - February 28</u>	X	X
<u>Penewawa Creek (35.0916)</u>	<u>July 16 - December 15</u>	X	=
<u>Wawawi Canyon Creek (35.1165)</u>	<u>July 16 - December 15</u>	X	=
<u>Yakima County</u>	<u>June 1 - September 15</u>	X	=
<u>Glade Creek (31.0851)</u>	<u>August 1 - September 30</u>	X	=
<u>Klickitat River (30.0002)</u>	<u>Submit Application</u>	=	=
<u>Yakima River (37.0002/38.0002/39.0002) - Mouth to Roza Dam</u>	<u>June 1 - September 15</u>	X	X
<u>Ahtanum Creek (37.1382)</u>	<u>June 16 - September 30</u>	X	=
<u>North Fork Ahtanum Creek (37.1382)</u>	<u>June 16 - August 15</u>	X	=
<u>North Fork Ahtanum Creek (37.1382) - Mouth to Foundation Creek</u>	<u>Submit Application</u>	=	=
<u>North Fork Ahtanum Creek (37.1382) - Upstream of Foundation Creek</u>	<u>Submit Application</u>	=	=
<u>South Fork Ahtanum Creek (37.1382)</u>	<u>Submit Application</u>	=	=
<u>Naches River (38.0003) - Mouth to Tieton River</u>	<u>July 1 - October 15</u>	X	X
<u>Naches River (38.0003) - Upstream of mouth of Tieton River to Bumping River</u>	<u>July 1 - August 15</u>	X	X
<u>Bumping River (38.0998)</u>	<u>July 16 - August 15</u>	X	X
<u>American River (38.1000)</u>	<u>Submit Application</u>	=	=
<u>Gold Creek (38.MISC)</u>	<u>July 16 - February 28</u>	X	=
<u>Kettle Creek (38.1033)</u>	<u>Submit Application</u>	=	=
<u>Miner Creek (38.1027)</u>	<u>July 16 - February 28</u>	X	=
<u>Morse Creek (38.1072) - Mouth to SR410 Crossing</u>	<u>August 1 - August 15</u>	X	=
<u>Morse Creek (38.1072) - Upstream of SR410 Crossing</u>	<u>August 1 - February 28</u>	X	=
<u>Rock Creek (38.MISC)</u>	<u>July 16 - February 28</u>	X	=
<u>Timber Creek (38.1062)</u>	<u>August 1 - August 15</u>	X	=
<u>Union Creek (38.1045) - Upstream of 500' above falls</u>	<u>August 1 - February 28</u>	X	=
<u>Union Creek (38.1045) - Mouth to 500' above falls</u>	<u>Submit Application</u>	=	=

<u>Washington Counties and State Waters</u> <u>Water Resource Inventory Area (WRIA) in parentheses</u>	<u>Mineral Prospecting Is Allowed Only Between These Dates</u>	<u>State Waters (and tributaries, unless otherwise indicated) in Which You May Use Mineral Prospecting Equipment With a Four Inch Maximum Suction Intake Hose Diameter</u>	<u>State Waters (NOT including tributaries) in Which You May Use Mineral Prospecting Equipment With a Five Inch Maximum Suction Intake Hose Diameter</u>
<u>Other American River tributaries not listed</u>	<u>August 1 - February 28</u>	X	=
<u>Deep Creek (38.MISC)</u>	<u>Submit Application</u>	=	=
<u>Copper Creek (38.MISC)</u>	<u>August 1 - August 15</u>	X	=
<u>Cowiche Creek (38.0005) - Mouth to South Fork Cowiche Creek</u>	<u>July 1 - September 30</u>	X	=
<u>North Fork Cowiche Creek (38.0008)</u>	<u>July 1 - February 28</u>	X	=
<u>South Fork Cowiche Creek (38.0031) - Mouth to Reynolds Creek</u>	<u>July 1 - September 30</u>	X	=
<u>South Fork Cowiche Creek (38.0031) - Upstream of Reynolds Creek</u>	<u>July 16 - October 31</u>	X	=
<u>Granite Creek (38.MISC)</u>	<u>August 1 - August 15</u>	X	=
<u>Little Naches River (38.0852) - Mouth to Matthews Creek</u>	<u>July 16 - August 15</u>	X	X
<u>Little Naches River (38.0852) - Upstream of Matthews Creek</u>	<u>July 16 - August 15</u>	X	=
<u>Crow Creek (38.0858)</u>	<u>July 16 - August 15</u>	X	=
<u>Nile Creek (38.0692)</u>	<u>July 16 - October 15</u>	X	=
<u>Rattlesnake Creek (38.0518)</u>	<u>July 16 - August 15</u>	X	=
<u>Tieton River (38.0166) - Mouth to Rimrock Dam</u>	<u>July 1 - August 31</u>	X	X
<u>North Fork Tieton River (38.0291) - Below Clear Lake Dam</u>	<u>Submit Application</u>	=	=
<u>North Fork Tieton River (38.0291) - Upstream of Clear Lake</u>	<u>July 1 - August 15</u>	X	=
<u>Clear Creek (38.0317)</u>	<u>July 16 - February 28</u>	X	=
<u>South Fork Tieton River (38.0374) - Below South Fork Falls</u>	<u>Submit Application</u>	=	=
<u>South Fork Tieton River (38.0374) - Upstream of South Fork Falls</u>	<u>July 16 - February 28</u>	X	=
<u>Indian Creek (38.0302)</u>	<u>Submit Application</u>	=	=
<u>Tributaries of Tieton River below Rimrock Dam</u>	<u>July 16 - February 28</u>	X	=
<u>Umtanum Creek (39.0553)</u>	<u>July 16 - September 30</u>	X	=
<u>Wenas Creek (39.0032)</u>	<u>July 16 - October 15</u>	X	=
<u>Other Yakima River tributaries</u>	<u>July 16 - August 31</u>	X	=
<u>Columbia River</u>	=	X	=
<u>Mouth to the I-205 Bridge</u>	<u>August 1 - March 31</u>	X	X
<u>I-205 Bridge to Bonneville Dam</u>	<u>July 16 - September 15</u>	X	X
<u>Bonneville Dam to Snake River</u>	<u>July 16 - February 28</u>	X	X
<u>Snake River to Priest Rapids Dam</u>	<u>July 16 - September 30</u>	X	X

<u>Washington Counties and State Waters</u> <u>Water Resource Inventory Area (WRIA) in parentheses</u>	<u>Mineral Prospecting Is Allowed Only Between These Dates</u>	<u>State Waters (and tributaries, unless otherwise indicated) in Which You May Use Mineral Prospecting Equipment With a Four Inch Maximum Suction Intake Hose Diameter</u>	<u>State Waters (NOT including tributaries) in Which You May Use Mineral Prospecting Equipment With a Five Inch Maximum Suction Intake Hose Diameter</u>
<u>Priest Rapids Dam to Mouth of Crab Creek</u>	<u>July 16 - February 28</u>	<u>X</u>	<u>X</u>
<u>Mouth of Crab Creek to Wanapum Dam</u>	<u>July 16 - September 30</u>	<u>X</u>	<u>X</u>
<u>Wanapum Dam to Chief Joseph Dam</u>	<u>July 16 - February 28</u>	<u>X</u>	<u>X</u>
<u>Chief Joseph Dam to Grand Coulee</u>	<u>June 16 - February 28</u>	<u>X</u>	<u>X</u>
<u>Upstream of Grand Coulee to Onion Creek</u>	<u>Submit Application</u>	=	=
<u>Onion Creek to Canadian Border</u>	<u>January 1 - December 31</u>	<u>X</u>	<u>X</u>
<u>All Columbia River tributaries</u>	<u>See county listings</u>	=	=
<u>Snake River</u>	=	<u>X</u>	=
<u>Mouth to Ice Harbor Dam</u>	<u>July 16 - September 30</u>	<u>X</u>	<u>X</u>
<u>Ice Harbor Dam to Mouth of Clearwater River</u>	<u>July 16 - March 31</u>	<u>X</u>	<u>X</u>
<u>Mouth of Clearwater River to State Line</u>	<u>August 1 - August 31</u>	<u>X</u>	<u>X</u>
<u>All Snake River tributaries</u>	<u>See county listings</u>	=	=
<u>Lakes</u>	<u>Submit Application</u>	=	=
<u>Salt water</u>	<u>Submit Application</u>	=	=
<u>All waters within national park, state park, or wilderness boundaries</u>	<u>Submit Application</u>	=	=

AMENDATORY SECTION (Amending Order 98-252, filed 12/16/98, effective 1/16/99)

WAC 220-110-020 Definitions. As used in this chapter, unless the context clearly requires otherwise:

(1) "Abandoning an excavation site" means not working an excavation site for forty-eight hours or longer.

(2) "Aggregate" means a mixture of minerals separable by mechanical or physical means.

((2)) (3) "Aquatic beneficial plant" means native and nonnative aquatic plants not prescribed by RCW 17.10.010 (10), and that are of value to fish life.

((3)) (4) "Aquatic noxious weed" means an aquatic weed on the state noxious weed list as prescribed by RCW 17.10.010(10).

((4)) (5) "Aquatic plant" means any aquatic noxious weed and aquatic beneficial plant that occurs within the ordinary high water line of waters of the state.

((5)) (6) "Artificial materials" means clean, inert materials that you use to construct diversion structures for mineral prospecting.

(7) "Bank" means any land surface above the ordinary high water line that adjoins a body of water and contains it except during floods. Bank also includes all land surfaces of

islands above the ordinary high water line that adjoin a ((water)) body of water and that are below the flood elevation of their surrounding ((water)) body of water.

((6)) (8) "Beach area" means the beds between the ordinary high water line and extreme low tide.

((7)) (9) "Bed" means the land below the ordinary high water lines of state waters. This definition shall not include irrigation ditches, canals, storm water run-off devices, or other artificial watercourses except where they exist in a natural watercourse that has been altered by man.

((8)) (10) "Bed materials" means naturally occurring material, including, but not limited to, gravel, cobble, rock, rubble, sand, mud and aquatic plants, found in the beds of state waters. Bed materials may be found in deposits or bars above the wetted perimeter of water bodies.

((9)) (11) "Biodegradable" means material that is capable of being readily decomposed by biological means, such as by bacteria.

((10)) (12) "Bioengineering" means project designs or construction methods which use live woody vegetation or a combination of live woody vegetation and specially developed natural or synthetic materials to establish a complex root grid within the existing bank which is resistant to ero-

sion, provides bank stability, and maintains a healthy riparian environment with habitat features important to fish life. Use of wood structures or limited use of clean angular rock may be allowable to provide stability for establishment of the vegetation.

((11)) (13) "Bottom barrier or screen" means synthetic or natural fiber sheets of material used to cover and kill plants growing on the bottom of a watercourse.

((12)) (14) "Boulder" means a stream substrate particle larger than ten inches in diameter.

((13)) (15) "Bulkhead" means a vertical or nearly vertical erosion protection structure placed parallel to the shoreline consisting of concrete, timber, steel, rock, or other permanent material not readily subject to erosion.

((14)) (16) "Classify" means to sort aggregate through a screen, grizzly, or similar device to remove the larger material and concentrate the remaining aggregate.

(17) "Cofferdam" means a temporary enclosure used to keep water from a work area.

(18) "Complete written application" means any document that serves as application for a written hydraulic project approval under WAC 220-110-030 which is signed and dated by the applicant and authorized agent, and contains general plans for the overall project, complete plans and specifications for the proposed construction or work waterward of the MHHW line in salt water, or waterward of the ordinary high water line in fresh water, complete plans and specifications for the proper protection of fish life, and notice of compliance with any applicable requirements of the State Environmental Policy Act, unless otherwise provided for in chapter 77.55 RCW.

(19) "Concentrator" means a device used to physically or mechanically separate and enrich the valuable mineral content of aggregate. ((Pans, sluice boxes and mini-rocker boxes are examples of concentrators.

(15) "Cofferdam" means a temporary enclosure used to keep water from a work area.

((16)) (20) "Control" means level of treatment of aquatic noxious weeds as prescribed by RCW 17.10.010(5).

((17)) (21) "Crevicing" means removing aggregate from cracks and crevices using hand-held mineral prospecting tools or water pressure.

(22) "Department" means the Washington department of fish and wildlife.

((18)) (23) "Diver-operated dredging" means the use of portable suction or hydraulic dredges held by SCUBA divers to remove aquatic plants.

((19)) (24) "Drawdown" means decreasing the level of standing water in a watercourse to expose bottom sediments and rooted plants.

((20)) (25) "Dredging" means removal of bed material using other than hand-held tools.

((21)) (26) "Early infestation" means an aquatic noxious weed whose stage of development, life history, or area of coverage makes one hundred percent control and eradication as prescribed by RCW 17.10.010(5) likely to occur.

((22)) (27) "Emergency" means an immediate threat to life, public or private property, or an immediate threat of serious environmental degradation, arising from weather or stream flow conditions, other natural conditions, or fire.

((23)) (28) "Entrained" means the entrapment of fish into a watercourse diversion without the presence of a screen, into high velocity water along the face of an improperly designed screen, or into the vegetation cut by a mechanical harvester.

((24)) (29) "Equipment" means any device powered by internal combustion; hydraulics; electricity, except less than one horsepower; or livestock used as draft animals, except saddle horses; and the lines, cables, arms, or extensions associated with the device.

((25)) (30) "Eradication(-)": See "control."

((26)) (31) "Established ford" means a crossing place in a watercourse that was in existence and annually used prior to 1986 or subsequently permitted by the department, and((-)) has identifiable approaches on the banks.

((27)) (32) "Excavation site" means the pit, furrow, or hole from which ~~(aggregate is being removed for the processing and recovery of)~~ you remove aggregate in order to process and recover minerals.

((28)) (33) "Extreme low tide" means the lowest level reached by a receding tide.

((29)) (34) "Farm and agricultural land" means those lands identified as such in RCW 84.34.020.

((30)) (35) "Filter blanket" means a layer or combination of layers of pervious materials (organic, mineral, or synthetic) designed and installed in such a manner as to provide drainage, yet prevent the movement of soil particles due to flowing water.

((31)) (36) "Fish life" means all fish species, including but not limited to food fish, shellfish, game fish, and other nonclassified fish species and all stages of development of those species.

((32)) (37) "Fishway" means any facility or device that is designed to enable fish to effectively pass around or through an obstruction without undue stress or delay.

((33)) (38) "Food fish" means those species of the classes Osteichthyes, Agnatha, and Chondrichthyes that shall not be fished for except as authorized by rule of the director of the Washington department of fish and wildlife.

((34)) (39) "Frequent scour zone" means the area between the wetted perimeter and the toe of the slope, comprised of aggregate, boulders, or bedrock. Organic soils are not present in the frequent scour zone.

(40) "Freshwater area" means those state waters and associated beds below the ordinary high water line that are upstream of river mouths including all lakes, ponds, and streams.

((35)) (41) "Game fish" means those species of the class Osteichthyes that shall not be fished for except as authorized by rule of the Washington fish and wildlife commission.

((36)) (42) "Ganged equipment" means two or more pieces of mineral prospecting equipment coupled together to increase efficiency. An example is adding a second sluice to a high-banker within the flow of water and aggregate.

(43) "General provisions" means those provisions that are contained in every HPA.

((37)) (44) "Gold and Fish pamphlet" means a document that details the rules for conducting small-scale and other prospecting and mining activities, and which serves as

the hydraulic project approval for certain mineral prospecting and mining activities in Washington state.

~~(45) "Habitat improvement structures or stream channel improvements" means natural or human-made materials placed in or next to water bodies to make existing conditions better. Rock flow deflectors, engineered logjams, and artificial riffles are examples.~~

(46) "Hand cutting" means the removal or control of aquatic plants with the use of hand-held tools or equipment, or equipment that is carried by a person when used.

~~((38) "Hand-held tools" means tools that are held by hand and are not powered by internal combustion, hydraulics, pneumatics, or electricity. Some examples of hand-held tools are shovels, rakes, hammers, pry bars and cable winches.~~

~~(39))~~ (47) "Hand-held mineral prospecting tools" means:

(a) Tools that you hold by hand and are not powered by internal combustion, hydraulics, or pneumatics. Examples include metal detectors, shovels, trowels, rakes, hammers, pry bars, hand-operated winches, and battery-operated pumps specific to prospecting; and

(b) Vac-pacs.

(48) "Hatchery" means any water impoundment or facility used for the captive spawning, hatching, or rearing of fish and shellfish.

~~((40) "Highbanker" means a stationary concentrator capable of being operated outside the wetted perimeter of the water body from which water is removed, and which is used to separate gold and other minerals from aggregate with the use of water supplied by hand or pumping, and consisting of a sluice box, hopper, and water supply. Aggregate is supplied to the highbanker by means other than suction dredging. This definition excludes mini-rocker boxes.~~

(41) "Highbanking" means the use of a highbanker for the recovery of minerals.

~~(42))~~ (49) "High-banker" means a stationary concentrator that you can operate outside the wetted perimeter of the body of water from which the water is removed, using water supplied by hand or by pumping. A high-banker consists of a sluice box, hopper, and water supply. You supply aggregate to the high-banker by means other than suction dredging. This definition excludes rocker boxes. See Figure 1.



Figure 1: Highbanker

(50) "High-banking" means using a high-banker to recover minerals.

(51) "Hydraulic project" means construction or performance of other work that will use, divert, obstruct, or change the natural flow or bed of any of the salt or fresh waters of the state. Hydraulic projects include forest practice activities, conducted pursuant to the forest practices rules (Title 222 WAC), that involve construction or performance of other work in or across the ordinary high water line of:

(a) Type 1-3 waters; or

(b) Type 4 and 5 waters with identifiable bed or banks where there is a hatchery water intake within two miles downstream; or

(c) Type 4 and 5 waters with identifiable bed or banks within one-fourth mile of Type 1-3 waters where any of the following conditions apply:

(i) Where the removal of timber adjacent to the stream is likely to result in entry of felled trees into flowing channels;

(ii) Where there is any felling, skidding, or ground lead yarding through flowing water, or through dry channels with identifiable bed or banks with gradient greater than twenty percent;

(iii) Where riparian or wetland leave trees are required and cable tailholds are on the opposite side of the channel;

(iv) Where road construction or placement of culverts occurs in flowing water;

(v) Where timber is yarded in or across flowing water;

(d) Type 4 and 5 waters with identifiable bed or banks that are likely to adversely affect fish life, where the HPA requirement is noted by the department in response to the forest practice application.

Hydraulic projects and associated permit requirements for specific project types are further defined in other sections of this chapter.

~~((43) "Hydraulic project application" means a form provided by and submitted to the department of fish and wildlife accompanied by plans and specifications of the proposed hydraulic project.~~

~~(44))~~ (52) "Hydraulic project approval" (HPA) means:

(a) A written approval for a hydraulic project signed by the director of the department of fish and wildlife, or the director's designates; or

(b) A verbal approval for an emergency hydraulic project from the director of the department of fish and wildlife, or the director's designates; or

(c) The following printed pamphlet approvals ~~((and any supplemental approvals to them. See "supplemental approval"))~~:

(i) A "Gold and Fish" pamphlet issued by the department, which identifies and authorizes specific minor hydraulic project activities for mineral prospecting and placer mining; or

(ii) An "Irrigation and Fish" pamphlet issued by the department, which identifies and authorizes specific minor hydraulic project activities; or

(iii) An "Aquatic Plants and Fish" pamphlet and any supplemental approvals to it issued by the department, which identifies and authorizes specific aquatic noxious weed and aquatic beneficial plant removal and control activities.

~~((45))~~ "Hydraulic" means the use of water spray or water under pressure to dislodge minerals and other material.

~~((46))~~ (53) "Job site" means the space of ground including and immediately adjacent to the area where work is conducted under the authority of ~~((a hydraulic project approval))~~ an HPA. For mineral prospecting and placer mining projects, the job site includes the excavation site.

~~((47))~~ (54) "Joint aquatic resources project application" or "JARPA" means a form provided by the department and other agencies which an applicant submits when requesting a written HPA for a hydraulic project.

(55) "Lake" means any natural or impounded body of standing freshwater, except impoundments of the Columbia and Snake rivers.

~~((48))~~ (56) "Large woody material" means trees or tree parts larger than four inches in diameter and longer than six feet, and rootwads, wholly or partially waterward of the ordinary high water line.

~~((49))~~ (57) "Mean higher high water" or "MHHW" means the tidal elevation obtained by averaging each day's highest tide at a particular location over a period of nineteen years. It is measured from the MLLW = 0.0 tidal elevation.

~~((50))~~ (58) "Mean lower low water" or "MLLW" means the 0.0 tidal elevation. It is determined by averaging each ~~((days'))~~ day's lowest tide at a particular location over a period of nineteen years. It is the tidal datum for vertical tidal references in the saltwater area.

~~((51))~~ (59) "Mechanical harvesting and cutting" means the partial removal or control of aquatic plants with the use of aquatic mechanical harvesters, which cut and collect aquatic plants, and mechanical cutters, which only cut aquatic plants.

~~((52))~~ "Mineral prospecting equipment" means any natural or manufactured device, implement, or animal other than the human body used in any aspect of prospecting for or recovering minerals. Classifications of mineral prospecting equipment are as follows:

(a) Class 0 – nonmotorized pans:

(b) Class I:

(i) Pans:

(ii) Nonmotorized sluice boxes, concentrators and mini-rocker boxes with a riffle area not exceeding ten square feet, and not exceeding fifty percent of the width of the wetted perimeter of the stream.

(c) Class II:

(i) Suction dredges with a maximum nozzle size of four inches inside diameter.

(ii) Highbankers or suction dredge/highbanker combinations with a maximum water intake size of two and one-half inches inside diameter, when operated wholly below the ordinary high water line.

(d) Class III:

(i) Highbankers supplied with water from a pump with a maximum water intake size of two and one-half inches inside diameter, when used to process aggregate at locations two hundred feet or greater landward of the ordinary high water line.

(ii) Suction dredge/highbanker combinations supplied with water from a pump with a maximum water intake size of two and one-half inches inside diameter, when used to pro-

cess aggregate at locations two hundred feet or greater landward of the ordinary high water line.

~~((iii))~~ Other concentrators supplied with water from a pump with a maximum water intake size of two and one-half inches inside diameter, when used to process aggregate at locations two hundred feet or greater landward of the ordinary high water line.

~~((53))~~ (60) "Mineral prospect" means to excavate, process, or classify aggregate using hand-held mineral prospecting tools and mineral prospecting equipment.

(61) "Mineral prospecting equipment" means any natural or manufactured device, implement, or animal (other than the human body) that you use in any aspect of prospecting for or recovering minerals.

(62) "Mini high-banker" means a high-banker with a riffle area of three square feet or less. See Figure 2.



Figure 2: Mini high-banker

~~((63))~~ "Mini(-)rocker box" means a ~~((nonmotorized concentrator operated with a rocking motion and consisting of a hopper attached to a cradle and a sluice box with a riffle area not exceeding ten square feet. The mini-rocker box shall only be supplied with water by hand and be capable of being carried by one individual. A mini-rocker box shall not be considered a highbanker.~~

~~((54))~~ rocker box with a riffle area of three square feet or less. See Figure 3.

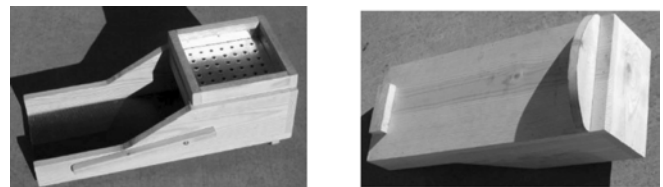

Figure 3: Mini rocker box (top view and bottom view)

(64) "Mining" means the production activity that follows mineral prospecting.

(65) "Mitigation" means actions ~~((which))~~ that shall be required as provisions of the HPA to avoid or compensate for impacts to fish life resulting from the proposed project activity. The type(s) of mitigation required shall be considered and

implemented, where feasible, in the following sequential order of preference:

- (a) Avoiding the impact altogether by not taking a certain action or parts of an action;
- (b) Minimizing impacts by limiting the degree or magnitude of the action and its implementation;
- (c) Rectifying the impact by repairing, rehabilitating, or restoring the affected environment;
- (d) Reducing or eliminating the impact over time by preservation and maintenance operations during the life of the action;
- (e) Compensating for the impact by replacing or providing substitute resources or environments; or
- (f) Monitoring the impact and taking appropriate corrective measures to achieve the identified goal.

For projects with potentially significant impacts, a mitigation agreement may be required prior to approval. Replacement mitigation may be required to be established and functional prior to project construction.

~~((55))~~ (66) "Natural conditions" means those conditions ~~((which))~~ that arise in or are found in nature. This is not meant to include artificial or manufactured conditions.

~~((56))~~ (67) "No-net-loss" means:

- (a) Avoidance or mitigation of adverse impacts to fish life; or
- (b) Avoidance or mitigation of net loss of habitat functions necessary to sustain fish life; or
- (c) Avoidance or mitigation of loss of area by habitat type.

Mitigation to achieve no-net-loss should benefit those organisms being impacted.

~~((57))~~ (68) "Ordinary high water line" means the mark on the shores of all waters that will be found by examining the bed and banks and ascertaining where the presence and action of waters are so common and usual and so long continued in ordinary years, as to mark upon the soil or vegetation a character distinct from that of the abutting upland~~((;))~~, provided~~((;))~~ that in any area where the ordinary high water line cannot be found, the ordinary high water line adjoining salt-water shall be the line of ~~((mean higher high water))~~ MHHW, and the ordinary high water line adjoining freshwater shall be the elevation of the mean annual flood.

~~((58))~~ (69) "Pan" means ~~((the following equipment used to separate gold or other metal from aggregate by washing:~~

- ~~(a) An open, metal or plastic dish operated by hand; or~~
- ~~(b) A motorized rotating open, metal or plastic dish without pumped or gravity-fed water supplies.~~

~~(59))~~ an open metal or plastic dish that you operate by hand to separate gold or other minerals from aggregate by washing the aggregate. See Figure 4.



Figure 4: Pan

~~((60))~~ (70) "Panning" means ~~((the use of))~~ using a pan to wash aggregate.

~~((61))~~ (71) "Person" means an individual or a public or private entity or organization. The term "person" includes local, state, and federal government agencies, and all business organizations.

~~((62))~~ (72) "Placer" means a glacial or alluvial deposit of gravel or sand containing eroded particles of minerals.

~~((63))~~ (73) "Pool" means a portion of the stream with reduced current velocity, often with water deeper than the surrounding areas.

~~((64))~~ (74) "Power sluice" means "high-banker."

(75) "Power sluice/suction dredge combination" means a machine that can be used as a power sluice, or with minor modifications, as a suction dredge. See Figure 5.



Figure 5: Power sluice/suction dredge combination

(76) "Process aggregate" or "processing aggregate" means the physical or mechanical separation or enrichment of the valuable mineral content within aggregate.

(77) "Prospecting" means the exploration for minerals and mineral deposits.

(78) "Protection of fish life" means prevention of loss or injury to fish or shellfish, and protection of the habitat that supports fish and shellfish populations.

~~((64))~~ (79) "Purple loosestrife" means *Lythrum salicaria* and *Lythrum virgatum* as prescribed in RCW 17.10.010 (10) and defined in RCW 17.26.020 (5)(b).

~~((65))~~ (80) "Redd" means a nest made in gravel, consisting of a depression dug by a fish for egg deposition, and associated gravel mounds. See Figure 6.

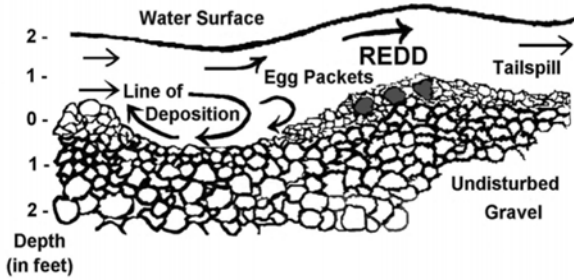

Figure 6: Cross section of a typical redd

(81) "Riffle" means the bottom of a concentrator containing a series of interstices or grooves to catch and retain a mineral such as gold.

((66)) (82) "River or stream." See "watercourse."

((67)) (83) "Rocker box" means a nonmotorized concentrator consisting of a hopper attached to a cradle and a sluice box that you operate with a rocking motion. See Figure 7.

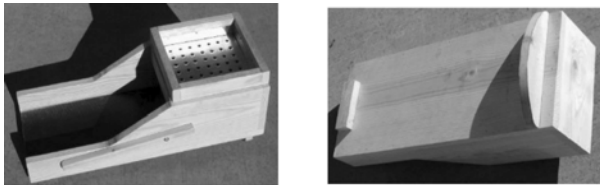

Figure 7: Rocker box (top view and bottom view)

(84) "Rotovation" means the use of aquatic rotovators which have underwater rototiller-like blades to uproot aquatic plants as a means of plant control.

((68)) (85) "Saltwater area" means those state waters and associated beds below the ordinary high water line and downstream of river mouths.

((69)) (86) "Shellfish" means those species of saltwater and freshwater invertebrates that shall not be taken except as authorized by rule of the director of the department of fish and wildlife. The term "shellfish" includes all stages of development and the bodily parts of shellfish species.

((70)) (87) "Slope" means:

(a) Any land surface above the frequent scour zone and wetted perimeter that adjoins a body of water. Slope also includes land surfaces of islands above the frequent scour zone that adjoin a body of water; or

(b) A stretch of ground forming a natural or artificial incline.

(88) "Sluice ((6x))" means a trough equipped with riffles across its bottom, ((used to recover gold and other minerals with the use of water).

(71) "Sluicing" means the use of a sluice box for the recovery of gold and other minerals.

~~(72) "Small scale mineral prospecting equipment" encompasses the equipment included in "mineral prospecting equipment, Class I."~~

~~(73)) which you use to recover gold and other minerals with the use of flowing water. See Figure 8.~~

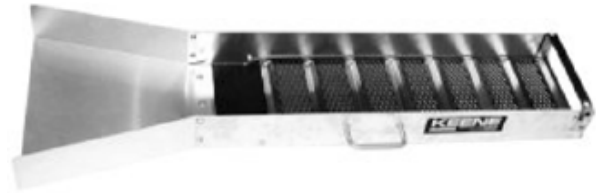

Figure 8: Sluice

(89) "Spartina" means *Spartina alterniflora*, *Spartina anglica*, *Spartina x townsendii*, and *Spartina patens* as prescribed in RCW 17.10.010(10) and defined in RCW 17.26.020 (5)(a).

((74)) (90) "Special provisions" means those conditions that are a part of the HPA, but are site- or project-specific, and are used to supplement or amend the technical provisions.

((75)) (91) "Spiral wheel" means a battery powered rotating pan that you use to recover gold and minerals with the help of water. See Figure 9.



Figure 9: Spiral wheel

(92) "Stream-bank stabilization" means those projects which prevent or limit erosion, slippage, and mass wasting((;)), including, but not limited to, bank resloping, log and debris relocation or removal, planting of woody vegetation, bank protection (physical armoring of banks using rock or woody material, or placement of jetties or groins), gravel removal, or erosion control.

~~((76)) (93) "Suction dredge" means a machine ((equipped with an internal combustion engine or electric motor powering a water pump which is used)) that you can use to move submerged ((bed materials by means of)) aggregate via hydraulic suction. ((These bed materials are processed)) You process the aggregate through an attached sluice box for the recovery of gold and other minerals. See Figure 10.~~

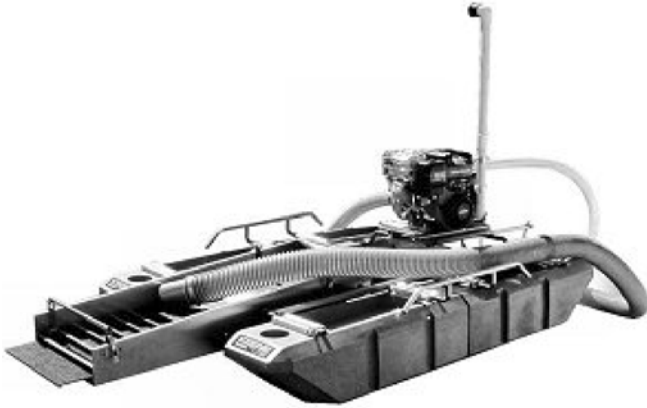

Figure 10: Suction dredge

~~((77))~~ (94) "Suction dredging" means ~~((the use of))~~ using a suction dredge for the recovery of gold and other minerals.

~~((78))~~ (95) "Supplemental approval" means a written addendum issued by the department to ~~((a))~~ an *Aquatic Plants and Fish* pamphlet HPA for approved exceptions to conditions of that pamphlet HPA or for any additional authorization by the department when required by ~~((a))~~ the pamphlet HPA. See "hydraulic project approval."

~~((79))~~ (96) "Tailings" means the waste material ~~((remaining))~~ that remains after ~~((processing))~~ you process aggregate for minerals.

~~((80))~~ (97) "Technical provisions" means those conditions that are a part of the HPA and apply to most projects of that nature.

~~((81))~~ (98) "Toe of the bank" means the distinct break in slope between the stream bank or shoreline and the stream bottom or marine beach or bed, excluding areas of sloughing. For steep banks that extend into the water, the toe may be submerged below the ordinary high water line. For artificial structures, such as jetties or bulkheads, the toe refers to the base of the structure, where it meets the stream bed or marine beach or bed.

~~((82))~~ (99) "Toe of the slope" means the base or bottom of a slope at the point where the ground surface abruptly changes to a significantly flatter grade.

(100) "Unstable slope" means a slope with visible evidence of slumping, sloughing or other movement. Evidence of unstable slopes includes landslides, uprooted or tilted trees, exposed soils, water-saturated soils, and mud, or the recent erosion of soils and sediment. Woody vegetation is typically not present on unstable slopes.

(101) "Vac-pac" means a motorized, portable vacuum used for prospecting. See Figure 11.



Figure 11: Vac pac

(102) "Viable" means that any plant or plant part is capable of taking root or living when introduced into a body of water.

~~((83))~~ (103) "Watercourse" and "river or stream" means any portion of a channel, bed, bank, or bottom waterward of the ordinary high water line of waters of the state, including areas in which fish may spawn, reside, or ~~((through which they may))~~ pass, and tributary waters with defined bed or banks, which influence the quality of fish habitat downstream. This includes watercourses which flow on an intermittent basis or which fluctuate in level during the year and applies to the entire bed of such watercourse whether or not the water is at peak level. This definition does not include irrigation ditches, canals, storm water run-off devices, or other entirely artificial watercourses, except where they exist in a natural watercourse ~~((which))~~ that has been altered by humans.

~~((84))~~ (104) "Water right" means a certificate of water right, a vested water right or a claim to a valid vested water right, or a water permit, pursuant to Title 90 RCW.

~~((85))~~ (105) "Waters of the state" or "state waters" means all salt waters and fresh waters waterward of ordinary high water lines and within the territorial boundaries of the state.

~~((86))~~ (106) "Water type" means water categories as defined in WAC 222-16-030 of the forest practice rules and regulations.

~~((87))~~ (107) "Weed rolling" means the use of a mechanical roller designed to control aquatic plant growth.

~~((88))~~ (108) "Wetted perimeter" means the areas of a watercourse covered with flowing or nonflowing water~~((; flowing or nonflowing)).~~

(109) "Woody vegetation" means perennial trees and shrubs having stiff stems and bark. Woody vegetation does not include grasses, forbs, or annual plants.

AMENDATORY SECTION (Amending Order 94-160, filed 11/14/94, effective 12/15/94)

WAC 220-110-030 Hydraulic project approvals—Procedures. (1) A person shall obtain an HPA before conducting a hydraulic project.

(2) ~~((A person seeking an HPA shall submit))~~ Receipt by the department of any one of the following documents constitutes an application for a written HPA:

(a) A joint aquatic resources permit application (JARPA) submitted to the department;

(b) A forest practice application submitted to the department of natural resources, if the hydraulic project is part of a forest practice as defined in WAC 222-16-010; or

(c) A section 10 or 404 public notice circulated by the United States Army Corps of Engineers or United States Coast Guard.

(3) You shall request a written HPA by submitting a complete written application to the department. ~~((The))~~ You shall request a pamphlet HPA by following the procedures in WAC 220-110-031. Your application for a written HPA shall contain general plans for the overall project, complete plans and specifications for the proposed construction or work waterward of the ~~((mean higher high water))~~ MHHW line in salt water, ~~((and))~~ complete plans and specifications for the proper protection of fish life, and notice of compliance with any applicable requirements of the State Environmental Policy Act, unless otherwise provided for in chapter 77.55 RCW. You and your agent must sign and date the application ~~((shall be signed and dated by the applicant or their agent.~~

~~(3) Receipt of any one of the following documents constitutes application for an HPA:~~

~~(a) A completed hydraulic project application submitted to the department;~~

~~(b) A completed forest practice application submitted to the department of natural resources, if the hydraulic project is part of a forest practice as defined in WAC 222-16-010; or~~

~~(c) A section 10 or 404 public notice circulated by the United States Army Corps of Engineers or United States Coast Guard).~~

(4) The department shall grant or deny approval within forty-five calendar days of the receipt of a complete written application ~~((and notice of compliance with any applicable requirements of the State Environmental Policy Act (SEPA) (chapter 43.21C RCW)))~~. The department shall strive to issue HPAs in less than thirty days. The forty-five day requirement shall be suspended if:

(a) ~~((An incomplete application is received;~~

~~((b)))~~ The site is physically inaccessible for inspection;

~~((c)))~~ (b) You or your agent remains unavailable or unable to arrange for a timely field evaluation of the proposed project after ten working days of the department's receipt of the application ~~((the applicant remains unavailable or unable to arrange for a timely field evaluation of the proposed project))~~;

~~((d) The applicant))~~ (c) You or your agent requests a delay;

(d) The department is issuing a permit for a storm water discharge and is complying with the requirements of RCW 77.55.161 (3)(b); or

(e) The department is reviewing the application as part of a multiagency permit streamlining effort and all participating permitting agencies and the permit applicant agree to an extended timeline longer than forty-five calendar days.

(5) Immediately upon determination that the forty-five day period is suspended, the department shall notify the applicant in writing of the reasons for the delay.

(6) The department or the county legislative authority may determine an imminent danger exists. The county legislative authority shall notify the department, in writing, if it determines that an imminent danger exists. In cases of imminent danger, the department shall issue an expedited written permit, upon request, for work to remove any obstructions, repair existing structures, restore banks, protect fish resources, or protect property.

(7) The department may issue an expedited written HPA in those instances where normal processing would result in ~~((unanticipated extreme))~~ significant hardship for the applicant, or unacceptable environmental damage would occur. ~~((An expedited HPA may be granted upon request for work to repair existing structures, move obstructions, restore banks, protect property, or protect fish resources that are subject to imminent danger by weather, flow, or other natural conditions.))~~

(8) Expedited HPA requests require a complete written application and shall take precedence over other non-emergency applications ~~((and))~~. These will ~~((normally))~~ be issued within ~~((ten))~~ fifteen calendar days of ~~((request))~~ receipt of a complete written application. ~~((All SEPA requirements shall be met prior to issuance of an expedited HPA.))~~ The provisions of the State Environmental Policy Act, chapter 43.21C RCW, are not required for expedited written HPAs.

~~((7))~~ (9) The county legislative authority or the department may declare an emergency or continue an existing declaration of an emergency where there is an immediate threat to life, the public, property, or of environmental degradation. Upon the declaration of an emergency, the department shall grant verbal approval ~~((shall be granted))~~ immediately upon request for ~~((emergency work to repair existing structures, move obstructions, restore banks, or protect property that is subject to immediate danger by weather, flow, or other natural conditions. Verbal approval shall be granted immediately upon request for driving across a stream during an emergency, as defined in WAC 220-110-020))~~ a stream crossing, or work to remove any obstructions, repair existing obstructions, restore streambanks, protect fish life, or protect property threatened by the stream or a change in the stream flow. The verbal approval shall be obtained prior to commencing emergency work and the department must issue a written HPA reflecting the conditions of the verbal approval within thirty days. The provisions of the State Environmental Policy Act, chapter 43.21C RCW, are not required for emergency HPAs.

~~((8))~~ (10) The department may accept written or verbal requests for time extensions, renewals, or alterations of an existing HPA. The request must be processed within forty-five calendar days of receipt of the request. Approvals of such requests shall be in writing. Transfer of an HPA to a new permittee requires written request by the original permittee or their agent and such request shall include the HPA number.

This written request shall be in a form acceptable to the department and shall ~~((contain an affirmation by))~~ include a statement that the new permittee ((that he/she)) agrees to be bound by the conditions ((on)) in the HPA. ((Project activity)) The new permittee shall not ((be conducted by the new permittee)) conduct any project activities until ((approval has been issued by)) the department has issued approval.

~~((9))~~ (11) Each HPA is usually specific to a watercourse, stating the exact location of the project site, and usually consists of general, technical, and special provisions.

~~((10))~~ (12) The written HPA, or clear reproduction, shall be on the project site when work is being conducted and shall be immediately available for inspection.

~~((11-All))~~ (13) The department may grant HPAs ((may be granted)) for a period of up to five years. Permittees shall demonstrate substantial progress on construction of that portion of the project relating to the (HPA) within two years of the date of issuance. The following types of HPAs issued under RCW ((75.20.103)) 77.55.021 shall remain in effect without the need for periodic renewal, provided the permittee notifies the department before commencing ((the)) work each year(-):

(a) Work of a seasonal nature that diverts water for irrigation or stock watering purposes(-); and

(b) Stream-bank stabilization projects if the problem causing the erosion occurs on an annual or more frequent basis as demonstrated by the applicant. Evidence of erosion may include, but is not limited to, history of permit application, approval, or photographs. Periodic ~~((flood waters))~~ floodwaters by themselves do not constitute ~~((the))~~ a problem that requires ~~((a))~~ an HPA.

~~((12- A hydraulic project application))~~ (14) An HPA shall be denied when, in the judgment of the department, the project will result in direct or indirect harm to fish life, unless adequate mitigation can be assured by conditioning the HPA or modifying the proposal. If approval is denied, the department shall provide the applicant, in writing, a statement of the specific reason(s) why and how the proposed project would adversely affect fish life.

~~((13))~~ (15) Protection of fish life shall be the only grounds upon which the department may deny or condition an HPA ((may be denied or conditioned)).

~~((14))~~ (16) The department may place specific time limitations on project activities in HPAs ((may have specific time limitations on project activities)) to protect fish life.

~~((15))~~ (17) HPAs do not exempt the applicant from obtaining other appropriate permits and following the rules or regulations of local, federal, and other Washington state agencies.

~~((16- Administration of))~~ (18) The department shall administer this chapter ((shall be conducted)) in compliance with SEPA, chapter 43.21C RCW, and chapters 197-11, 220-100, and 232-19 WAC.

~~((17- All HPAs issued pursuant to RCW 75.20.100 and 75.20.160 may be subject to additional restrictions, conditions, or revocation if the department determines that new biological or physical information indicates the need for such action. The permittee has the right to request an informal or formal appeal in accordance with chapter 34.05 RCW. All HPAs issued pursuant to RCW 75.20.103 may be modified~~

~~by the department due to changed conditions after consultation with the permittee. Provided however, That modifications of HPAs issued pursuant to RCW 75.20.103 and 75.20.160 shall be subject to appeal to the hydraulic appeals board established in RCW 75.20.130.)~~ (19) The department may, after consultation with the permittee, modify an HPA due to changed conditions. The modification becomes effective unless appealed to the department or the hydraulic appeals board as specified in RCW 77.55.021(4), 77.55.301 (5), WAC 220-110-340 and 220-110-350.

AMENDATORY SECTION (Amending Order 98-252, filed 12/16/98, effective 1/16/99)

WAC 220-110-031 Pamphlet hydraulic project approvals—Procedures. (1) In those instances where a pamphlet is the equivalent of ~~((an HPA))~~ a hydraulic project approval (HPA) as defined in WAC 220-110-020~~((44))~~ (52), a person shall obtain a pamphlet HPA issued by the department, which identifies and authorizes specific minor hydraulic project activities before conducting a hydraulic project.

(2) You may submit requests for pamphlet HPAs to the department verbally or in writing.

(3) The department may grant exceptions to a pamphlet HPA if you apply for a written HPA as described in WAC 220-110-030, or for supplemental approvals to the Aquatic Plants and Fish pamphlet HPA as defined in WAC 220-110-020~~((44))~~ (52) and 220-110-020~~((78))~~ (95). Exceptions to a pamphlet HPA shall require written authorization by the department.

~~((3))~~ (4) You may submit applications ((submitted to the department)) for Aquatic Plants and Fish pamphlet supplemental approvals ((may be verbal or written)) verbally or in writing to the department.

(a) Your supplemental approval application((s)) shall specify the requested exception or request for additional authorization and shall include ((the applicant's)) your name, address and phone number. You shall sign and date written applications ((shall be signed and dated)).

(b) The department shall grant or deny a request for a supplemental approval within forty-five calendar days of the receipt of a request for supplemental approval.

~~((4- The supplemental approval shall be attached to the pamphlet HPA and shall be on the job site when work is being conducted and shall be immediately available for inspection.))~~

(5) Except as provided in WAC 220-110-201, you shall have the pamphlet HPA, ((or clear reproduction, shall be)) and any supplemental approvals to it on the job site when work is being conducted and shall ((be)) make them immediately available for inspection upon request.

(6) ~~((The pamphlet HPA shall be conditioned to ensure protection of fish life.))~~

~~((7))~~ Pamphlet HPAs do not exempt ((the applicant)) you from obtaining other appropriate permits and following the rules ((or)) and regulations of local, federal, and other Washington state agencies.

~~((8) Administration of this chapter shall be conducted in compliance with SEPA, chapter 43.21C RCW, and chapters 197-11, 220-100, and 232-19 WAC.))~~

AMENDATORY SECTION (Amending Order 98-252, filed 12/16/98, effective 1/16/99)

WAC 220-110-200 Mineral prospecting (~~(technical provisions)~~). WAC 220-110-201 through ~~((220-110-205))~~ 220-110-206 set forth ~~((technical provisions))~~ the rules necessary to protect fish life that ((shall)) apply to mineral prospecting and placer mining projects ((as necessary to protect fish life. Additional special provisions may be included in written HPAs as necessary to address site-specific conditions. Written HPAs shall also have specific time limitations on project activities to protect fish life. Timing limitations for projects conducted under authority of the *Gold and Fish* pamphlet are found in WAC 220-110-206 through 220-110-209. Saltwater provisions may be applied to tidally influenced areas upstream of river mouths and the mainstem Columbia River downstream of Bonneville Dam where applicable in written HPAs.)) Timing limitations for projects conducted under authority of the *Gold and Fish* pamphlet are found in WAC 220-110-206. A copy of the current *Gold and Fish* pamphlet is available from the department, and it contains the rules which you must follow when mineral prospecting under its authority. You may request exceptions to the *Gold and Fish* pamphlet by applying for an individual written HPA as indicated in WAC 220-110-031. The department may incorporate mitigation measures necessary to address site-specific conditions and protect fish life when authorizing individual written HPAs for mineral prospecting. The department may prohibit activities when prospecting and mining impacts adversely affect fish habitat for which no proven mitigation methods are available. The department may apply saltwater provisions to written HPAs for tidally influenced areas upstream of river mouths and the mainstem Columbia River downstream of Bonneville Dam where applicable.

AMENDATORY SECTION (Amending Order 98-252, filed 12/16/98, effective 1/16/99)

WAC 220-110-201 (~~(Common)~~) mineral prospecting (~~(technical provisions)~~) without timing restrictions. ~~((A copy of the current *Gold and Fish* pamphlet available from the department shall serve as an HPA, unless otherwise indicated, and be on the job site at all times. Mineral prospecting and placer mining projects authorized through a written HPA may incorporate additional mitigation measures as necessary to achieve no net loss of productive capacity of fish and shellfish habitat. Project activities may be prohibited where project impacts adversely affect fish habitats for which no proven mitigation methods are available. The following technical provisions shall apply to all mineral prospecting and placer mining projects:~~

~~(1) Excavation, collection and processing of aggregate from the bed shall comply with the timing and location restrictions specified in WAC 220-110-206 through 220-110-209. Excavation, collection and processing of aggregate~~

~~within the wetted perimeter shall only occur between 5:00 a.m. and 11:00 p.m.~~

~~(2) Excavation sites shall be separated by at least two hundred feet.~~

~~(3) There shall be no excavation, collection or processing of aggregate within four hundred feet of any fishway, dam or hatchery water intake.~~

~~(4) Except as specified in WAC 220-110-203, aggregate collected from outside the bed shall not be washed, sluiced, processed or deposited within two hundred feet landward of the ordinary high water line.~~

~~(5) A maximum of five individuals eight years of age and over may collect and process aggregate from any excavation site. No more than one pit, furrow or pothole at a time shall be excavated by any one individual.~~

~~(6) Excavations shall not occur between the ordinary high water line and two hundred feet landward of the ordinary high water line. Excavations between the ordinary high water line and the toe of the bank shall not result in undercutting below the ordinary high water line or in disturbance of land surfaces above the ordinary high water line.~~

~~(7) There shall be no disturbance of live rooted vegetation of any kind. Woody debris jams and large woody material shall not be disturbed in any manner.~~

~~(8) With the exception of aggregate excavated by a suction dredge, all excavations of aggregate shall only be performed by hand or with hand held tools. A maximum of one hand-operated cable, chain or rope winch may be used to move bed material below the ordinary high water line. Additional safety cables, chains or ropes may be attached to this material provided they do not offer a mechanical advantage and are used solely to hold material in place. The use of horses, other livestock or motorized mineral prospecting equipment, except those specifically authorized under WAC 220-110-203 through 220-110-205, is prohibited. Materials too large to be moved with a single hand-operated cable, chain or rope winch shall not be disturbed.~~

~~(9) Boulders may be moved only to facilitate collection of aggregate underneath them. Boulders shall be immediately replaced in their original location prior to working another excavation site or leaving the excavation site. Not working the excavation site for more than sixteen hours constitutes leaving the site.~~

~~(10) Only equipment, methods, locations and timing for processing aggregate specified in WAC 220-110-201 through 220-110-209 are authorized. Exceptions shall require additional authorization from the department in the form of a supplemental approval to the *Gold and Fish* pamphlet or a written HPA. A written HPA shall be required for exceptions in cases where "submit application" or "closed" is listed for state waters in WAC 220-110-206 through 220-110-209. Only the following exceptions may be authorized through a supplemental approval to the *Gold and Fish* pamphlet:~~

~~(a) Timing and location only for Class I and Class II mineral prospecting equipment.~~

~~(b) Location only for Class III mineral prospecting equipment.~~

~~(11) With the exception of sieves for classifying aggregate, mineral prospecting equipment shall not be combined in~~

series, joined or ganged with additional mineral prospecting equipment to increase the riffle area or efficiency of mineral recovery of a single piece of mineral prospecting equipment.

(12) There shall be no damming or diversion of the flowing stream except as provided in WAC 220-110-203 (4)(d).

(13) Prior to working another excavation site or leaving the excavation site, tailings of aggregate collected from below the ordinary high water line shall be returned to the location from which the aggregate was originally collected. Sand and lighter material washed away by the streamflow during aggregate processing and tailings resulting from suction dredging may be left where processed.

(14) Except as required in subsection (13) of this section, tailings shall not be deposited in existing pools.

(15) Incubating fish eggs or fry shall not be disturbed. If fish eggs or fry are encountered during excavation of the bed, operations shall immediately cease and the department shall be notified immediately. No further excavations shall occur until all eggs and fry have emerged from the gravel. Further approval shall be required by the department prior to resuming mineral prospecting or placer mining activities in that stream.

(16) Beds containing live freshwater mussels shall not be disturbed. If live mussels are encountered during excavation of the bed, operations shall immediately cease and shall be relocated a minimum of two hundred feet from them.

(17) All pits, furrows, tailing piles, and potholes created during excavation or processing of aggregate shall be leveled or refilled with bed materials or tailings prior to working another excavation site or leaving the excavation site. Not working the excavation site for more than sixteen hours constitutes leaving the site. No more than one pit, furrow or pothole at a time shall be excavated.

(18) Fish entrapped within pits, furrows or potholes created during excavation or processing of aggregate shall immediately be safely collected and returned to flowing waters and the pits, furrows or potholes leveled or filled.

(19) At no time shall mining or prospecting activity create a blockage or hindrance to either the upstream or downstream passage of fish.

(20) If at any time as a result of project activities or water quality problems, fish life are observed in distress or a fish kill occurs, operations shall cease and both the department and the department of ecology shall be notified of the problem immediately. Work shall not resume until further approval is given by the department. Additional measures to mitigate impacts may be required.

(21) No motorized, tracked, or wheeled vehicles shall be:

(a) Operated or allowed below the ordinary high water line of the stream; or

(b) Be operated so as to affect the bed or flow of waters of the state in any way.

(22) Entry onto private property or removal of minerals from an existing mining claim or state-owned lands without the permission of the landowner or claim holder is not authorized. The permittee is responsible for determining land ownership, land status (i.e., open to entry under the mining laws) and the status and ownership of any mining claims.

(23) Mercury and other hazardous materials shall not be used on the job site for amalgamating minerals.

(24) Mercury, lead and other hazardous materials removed from aggregate or collected in concentrators during processing of aggregate shall not be returned to waters of the state and shall be disposed of as specified by the department of ecology. Contact the department of ecology for direction on disposal.

(25) Once mining or prospecting at a job site is completed, or mining or prospecting is not conducted at the job site for more than one week, the job site shall be restored to preproject conditions, all disturbed areas shall be protected from erosion and revegetated with native plants, and all pits, furrows, tailing piles, and potholes shall be leveled or refilled as required in subsection (17) of this section.) You may mineral prospect year-round in all waters of the state, except lakes or salt waters. You must follow the rules listed below, but you do not need to have the rules with you or on the job site.

(1) You may use only hand-held mineral prospecting tools and the following mineral prospecting equipment when mineral prospecting without timing restrictions:

(a) Pans;

(b) Spiral wheels;

(c) Sluices, concentrators, mini rocker boxes, and mini high-bankers with riffle areas totaling three square feet or less, including ganged equipment.

(2) You may not use vehicle-mounted winches. You may use one motorized winch and one hand-operated winch to move boulders and large woody material that is not embedded, and additional cables, chains, or ropes to stabilize them.

(3) You may not disturb fish life or redds. If you observe or encounter fish life, redds, or actively spawning fish when collecting or processing aggregate, you must relocate your operations.

(4) Rules for excavating:

(a) You may excavate only by hand or with hand-held mineral prospecting tools.

(b) You may not excavate, collect, or remove aggregate from within the wetted perimeter. See Figures 1 and 2.

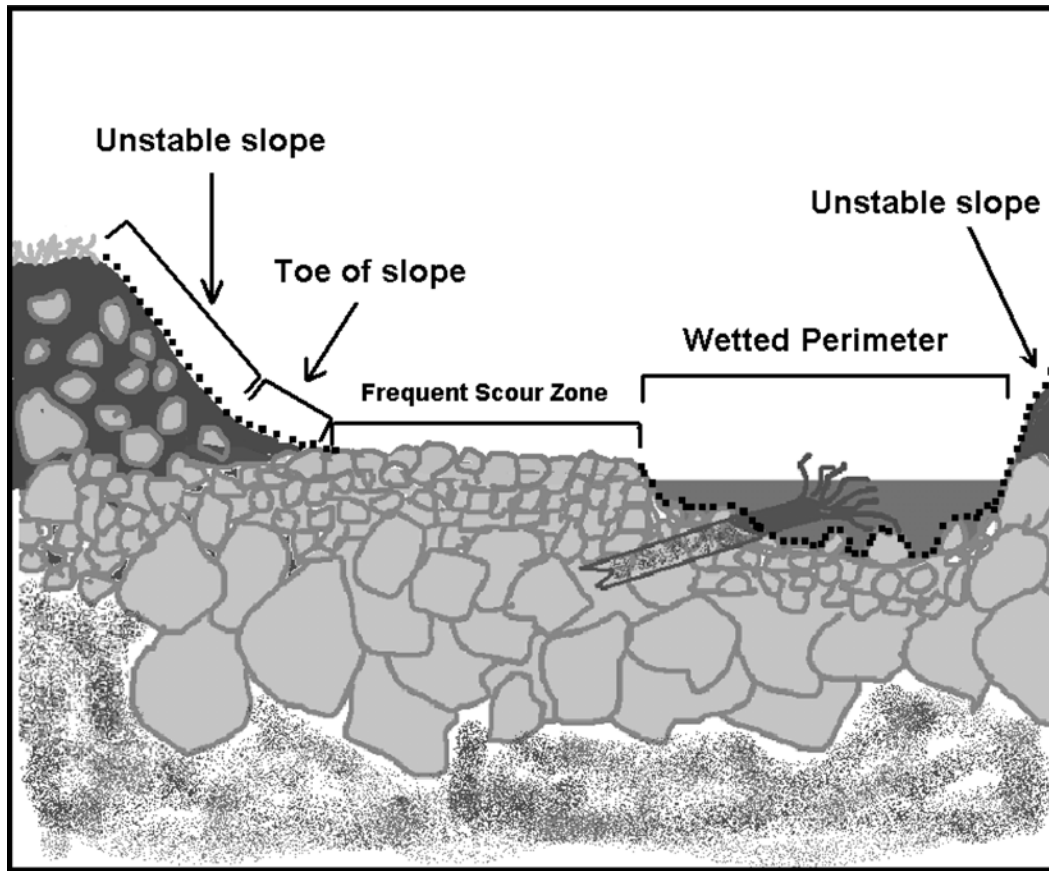

Figure 1: Cross section of a typical body of water, showing areas where excavation is not permitted under rules for mineral prospecting without timing restrictions. Dashed lines indicate areas where excavation is not permitted.

(c) Only one excavation site per individual is allowed. However, you may use a second excavation site as a settling pond. Multiple individuals may work within a single excavation site.

(d) You may not stand within, or allow aggregate to enter, the wetted perimeter when collecting or excavating aggregate.

(e) You must fill all excavation sites and level all tailing piles prior to moving to a new excavation site or abandoning an excavation site. If you move boulders, you must return them, as best as you can, to their approximate, original location.

(f) You may not undermine, move, or disturb large woody material embedded in the slopes or located wholly or partially within the wetted perimeter. You may move large woody material and boulders located entirely within the frequent scour zone, but you must keep them within the frequent scour zone. You may not cut large woody material. See Figure 2.

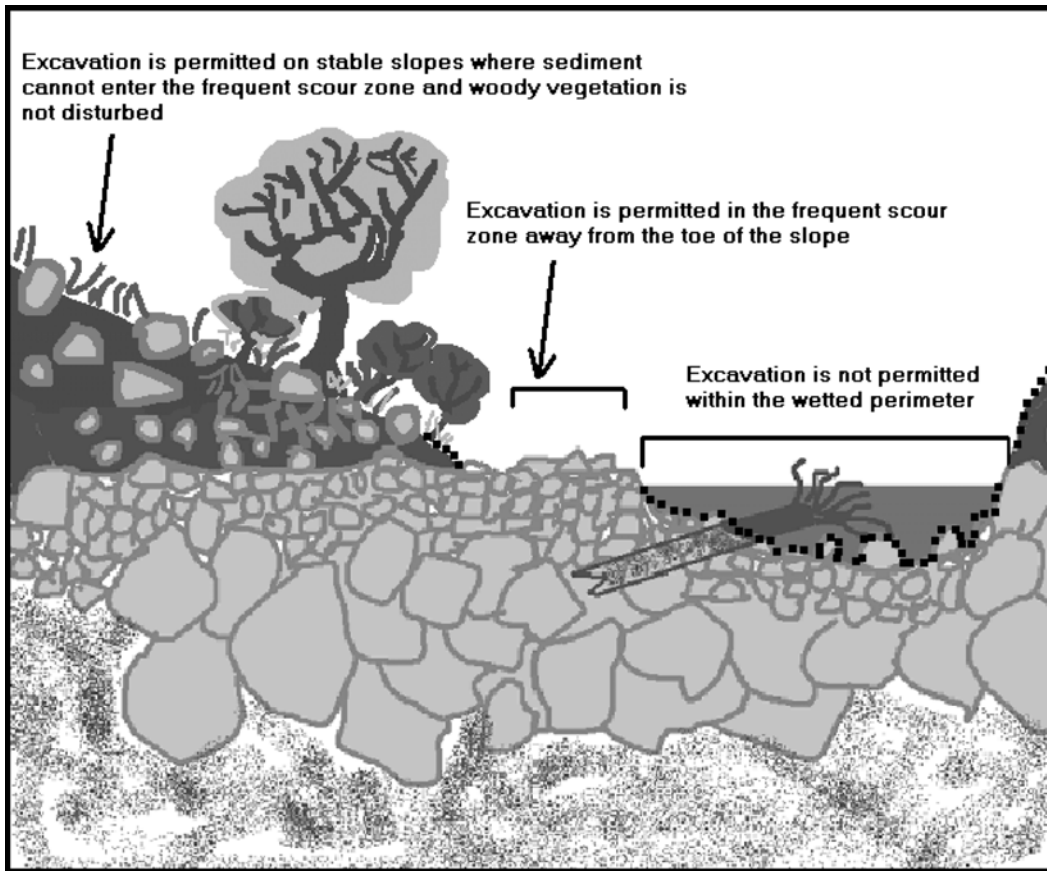

Figure 2: Permitted and prohibited excavation sites in a typical body of water under rules for mineral prospecting without timing restrictions. Dashed lines indicate areas where excavation is not permitted.

(g) You may not undermine, cut, or disturb live, rooted woody vegetation of any kind.

(h) You may not excavate or collect aggregate from an unstable slope, the toe of the slope, or a portion of the slope that delivers, or has the potential to deliver, sediment to the wetted perimeter or frequent scour zone. See Figures 3 and 4.

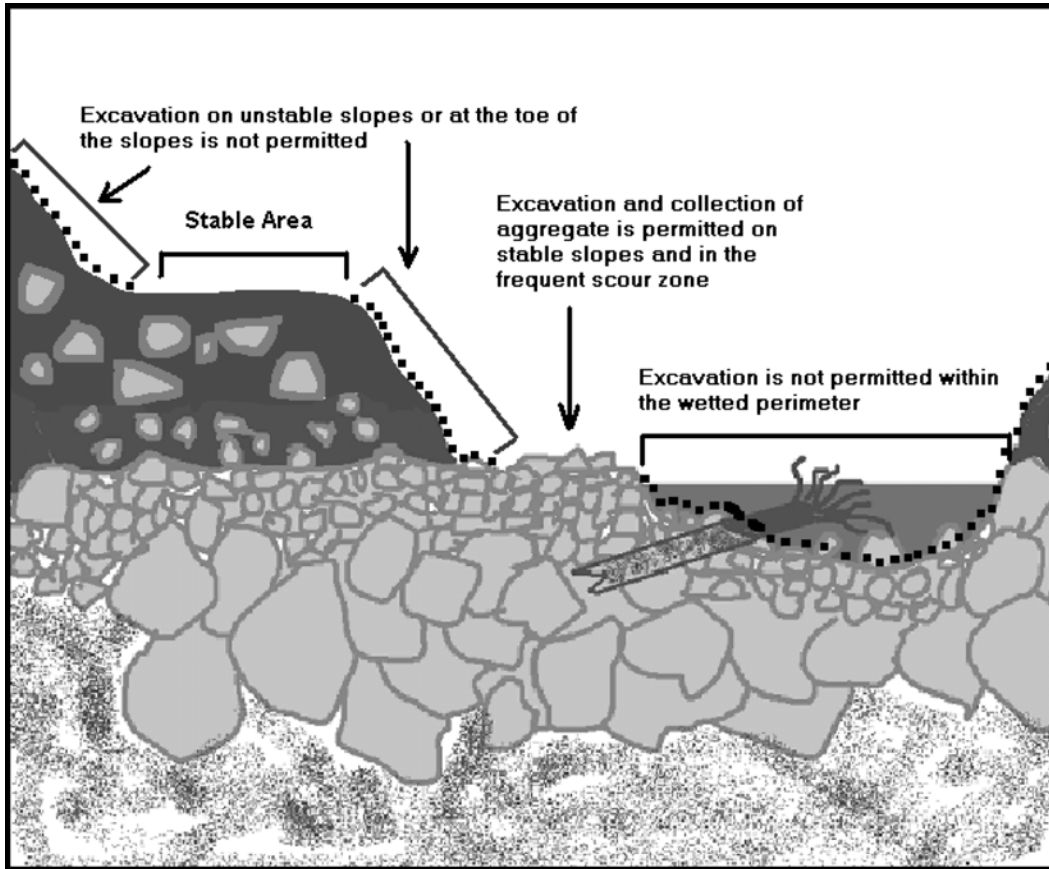

Figure 3: Cross section of a typical body of water, showing unstable slopes, stable areas, and permissible or prohibited excavation sites under rules for mineral prospecting without timing restrictions. Dashed line indicates areas where excavation is not permitted.

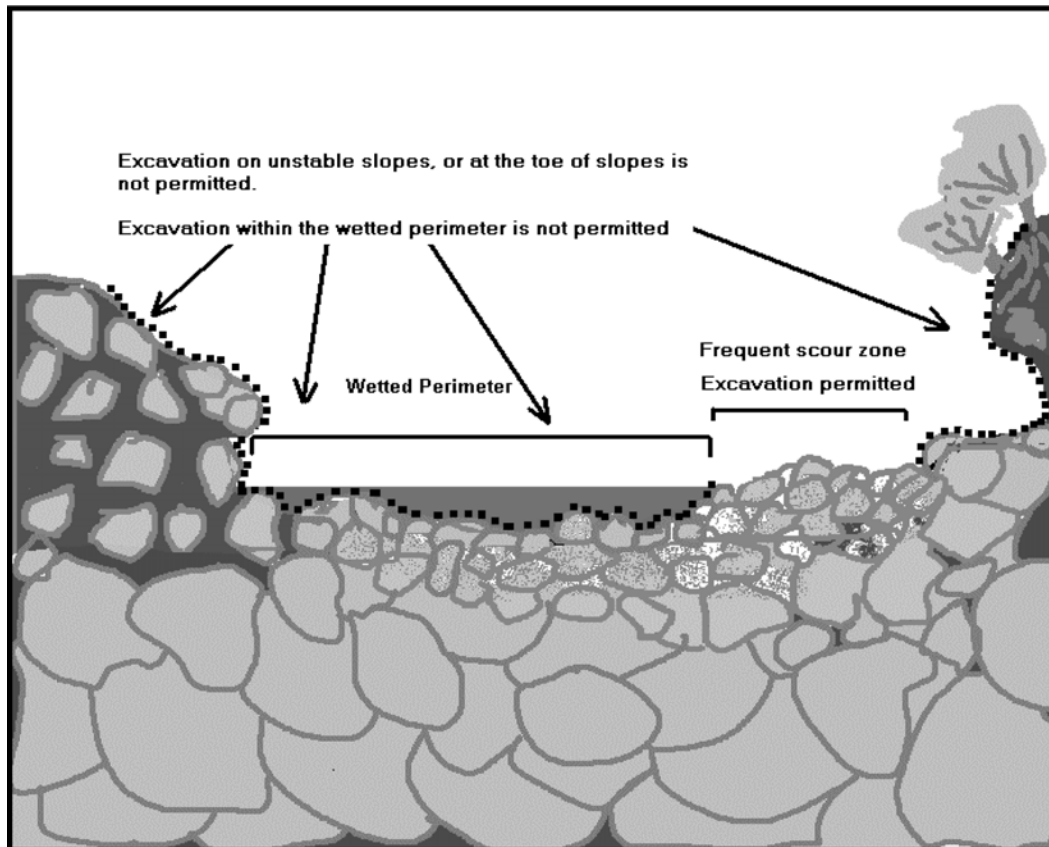

Figure 4: Cross section of a typical body of water showing unstable slopes, stable areas, and permissible or prohibited excavation sites under rules for mineral prospecting without timing restrictions. Dashed line indicates areas where excavation is not permitted.

(5) Rules for processing aggregate:

(a) You may not stand within the wetted perimeter when processing aggregate.

(b) You may not level or disturb tailing piles that remain within the wetted perimeter after processing aggregate.

(c) You must classify aggregate at the collection or excavation site prior to processing, if you collected or excavated it outside the frequent scour zone.

(d) You may process only classified aggregate within the wetted perimeter when using a sluice.

(e) You may not process directly on redds or disturb incubating fish life. You may not allow tailings, or a visible sediment plume (visibly muddy water), to enter redds or areas where fish life are located within the bed.

(f) The maximum width of a sluice, measured at its widest point, including attachments, shall not exceed twenty-five percent of the width of the wetted perimeter at the point of placement.

(g) You may process with a sluice only in areas within the wetted perimeter that are composed solely of boulders and bedrock. You must separate sluice locations by at least

fifty feet. You may not place structures within the wetted perimeter to check or divert the water flow.

(h) You may operate mini high-bankers or other concentrators only outside the wetted perimeter. You may only supply water to this equipment by hand or by a battery-operated pump with a screened intake. You may not allow visible sediment or muddy water to enter the wetted perimeter. A second excavation site may be used as a settling pond.

(i) Under RCW 77.57.010 and 77.57.070, any device you use for pumping water from fish-bearing waters must be equipped with a fish guard to prevent passage of fish into a pump intake. To prevent fish life from entering the system, you must screen the pump intake with either:

(i) Six one-hundredths inch (eighteen gauge) woven wire mesh with openings no greater than eighty-seven one-thousandths inches; or

(ii) A perforated plate with openings no greater than ninety-four one-thousandths inch (three thirty-seconds inch); or

(iii) A profile bar with openings no greater than one and seventy-five one-hundredths millimeter (sixty-nine one-thousandths inch).

The screened intake shall consist of a structure with sufficient surface area to ensure that the velocity through the screen is less than four-tenths feet per second. You must maintain screens to prevent injury to or entrapping fish life, and you must keep screens in place whenever water is withdrawn through a pump intake.

For every cubic foot per second (cfs) of water drawn through the pump, you must have at least two and one-half square feet of screen with holes of the correct size and spacing. Check the ratings plate on your pump or in the operator's manual to determine the maximum listed capacity. Size your screen according to that capacity, even if you don't normally run the pump that high. Be sure to use the pump intake rating and not the dredge capacity or water volume through the sluice.

Here are some helpful formulas and standards:

One cubic foot per second (cfs) equals four hundred fifty gallons per minute (gpm).

Minimum screen area = (Maximum pump intake volume in cfs) ÷ (four-tenths feet per second velocity through screen).

Screen must be at least two and one-half square feet per cfs of pump intake capacity.

The following example may help you calculate the minimum screen area for your pump intake:

Example:

- Your dredge pump manufacturer rates its maximum capacity at 250 gpm.
- By dividing 250 gpm by 450 gpm, you know that your pump draws 0.56 cfs.

(j) You may not excavate or process aggregate within four hundred feet of any fishway, dam, or hatchery water intake.

(k) You may not disturb existing habitat improvement structures or stream channel improvements.

(l) If at any time, as a result of project activities, you observe a fish kill or fish life in distress, you must immediately cease operations and notify the Washington department of fish and wildlife, and the Washington military department emergency management division, of the problem. You may not resume work until the Washington department of fish and wildlife gives approval. The Washington department of fish and wildlife may require additional measures to mitigate the prospecting impacts.

AMENDATORY SECTION (Amending Order 98-252, filed 12/16/98, effective 1/16/99)

WAC 220-110-202 ((Use of Class 0 mineral prospecting equipment.)) **Mineral prospecting with timing restrictions.** ((A copy of the current *Gold and Fish* pamphlet available from the department contains the rules which shall be followed when using Class 0 mineral prospecting equipment. A copy of the current *Gold and Fish* pamphlet shall be on the job site at all times. Mineral prospecting and placer mining projects authorized through a written HPA may incorporate additional mitigation measures as necessary to achieve no net loss of productive capacity of fish and shellfish habitat. Project activities may be prohibited where project impacts adversely affect fish habitats for which no proven mitigation

methods are available. The following technical provisions shall apply to all Class 0 mineral prospecting and placer mining projects:

(1) The common technical provisions as specified in WAC 220-110-201 and the timing and location restrictions as specified in WAC 220-110-209 shall apply to all mineral prospecting and placer mining projects conducted with Class 0 equipment.

(2) The use of a single hand-operated nonmotorized pan is authorized.

(3) Collection and processing of aggregate shall be limited to that portion of the bed above the wetted perimeter.)) You may mineral prospect only in the waters, during the times, and with the mineral prospecting equipment limitations identified in WAC 220-110-206. You must follow the rules listed below, and you must have the rules with you or on the job site.

(1) You may use only hand-held mineral prospecting tools and the following mineral prospecting equipment when mineral prospecting with timing restrictions:

(a) Pans;

(b) Spiral wheels;

(c) Sluices, concentrators, mini rocker boxes, and mini high-bankers with riffle areas totaling ten square feet or less, including ganged equipment;

(d) Suction dredges that have suction intake hoses with nominal inside diameters of five inches or less as measured at the junction of the nozzle and the hose, or by measuring the inside diameter of the hose. See Figure 1.

Dredge Intake Nozzle

Measurement to determine suction intake hose diameter may be made at the junction of the nozzle and hose, or by measuring the inside diameter of the hose

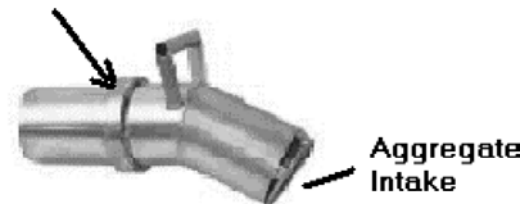

Figure 1: Dredge intake nozzle

(e) Power sluice/suction dredge combinations that have riffle areas totaling ten square feet or less, including ganged equipment, suction intake hoses with nominal inside diameters of five inches or less as measured at the junction of the nozzle and the hose, and pump intake hoses with inside diameters of four inches or less;

(f) High-bankers and power sluices that have riffle areas totaling ten square feet or less, including ganged equipment, and pump intake hoses with inside diameters of four inches or less.

(2) The widest point of a sluice, including attachments, shall not exceed twenty-five percent of the wetted perimeter at the point of placement.

(3) The suction intake hose diameter of suction dredges and power sluice/suction dredge combinations must not exceed the diameter allowed in the listing for the stream or stream reach where you are operating, as identified in WAC 220-110-206.

(4) You may not use vehicle-mounted winches. You may use one motorized winch and one hand-operated winch to move boulders and large woody material that is not embedded, and additional cables, chains, or ropes to stabilize them.

(5) Equipment separation:

(a) With the exception of sluices and rocker boxes with a riffle area exceeding three square feet, suction dredges, power sluice/suction dredge combinations, high-bankers, and power sluices, you may use mineral prospecting equipment as close to other mineral prospecting equipment as desired.

(b) You must separate by a minimum of two hundred feet as measured as a radius from the equipment all sluices and rocker boxes with a riffle area exceeding three square feet, suction dredges, power sluice/suction dredge combinations, high-bankers, and power sluices operating within the wetted perimeter. However, you may locate this equipment closer than two hundred feet if only one piece of equipment is operating. See Figure 2.

(c) You must separate by a minimum of two hundred feet as measured as a radius from the equipment all sluices and rocker boxes with a riffle area exceeding three square feet, suction dredges, power sluice/suction dredge combinations, high-bankers, and power sluices operating outside of the wetted perimeter that discharges tailings or wastewater to the wetted perimeter. However, you may locate this equipment closer than two hundred feet if only one piece of equipment is operating. See Figure 2.

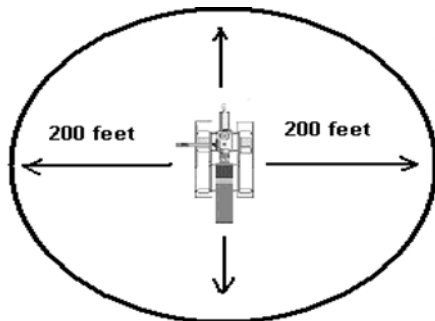

Figure 2: Equipment separation requirement

(6) Under RCW 77.57.010 and 77.57.070, any device you use for pumping water from fish-bearing waters must be equipped with a fish guard to prevent passage of fish into a pump intake. To prevent fish life from entering the system, you must screen the pump intake with either:

(a) Six one-hundredths inch (eighteen gauge) woven wire mesh with openings no greater than eighty-seven one-thousandths inches; or

(b) A perforated plate with openings no greater than ninety-four one-thousandths inch (three thirty-seconds inch); or

(c) A profile bar with openings no greater than one and seventy-five one-hundredths millimeter (sixty-nine one-thousandths inch).

The screened intake shall consist of a structure with sufficient surface area to ensure that the velocity through the screen is less than four-tenths feet per second. You must maintain screens to prevent injury to or entrapping fish life, and you must keep screens in place whenever water is withdrawn through a pump intake.

For every cubic foot per second (cfs) of water drawn through the pump, you must have at least two and one-half square feet of screen with holes of the correct size and spacing. Check the ratings plate on your pump or in the operator's manual to determine the maximum listed capacity. Size your screen according to that capacity, even if you don't normally run the pump that high. Be sure to use the pump intake rating and not the dredge capacity or water volume through the sluice.

Here are some helpful formulas and standards:

One cubic foot per second (cfs) equals four hundred fifty gallons per minute (gpm).

Minimum screen area = (Maximum pump intake volume in cfs) ÷ (four-tenths feet per second velocity through screen).

Screen must be at least two and one-half square feet per cfs of pump intake capacity.

The following example may help you calculate the minimum screen area for your pump intake:

Example:

- Your dredge pump manufacturer rates its maximum capacity at 250 gpm.
- By dividing 250 gpm by 450 gpm, you know that your pump draws 0.56 cfs.

(7) All equipment fueling and servicing must be done so that petroleum products do not get into the body of water. If a petroleum sheen is observed, you must contact the Washington military department emergency management division. You must immediately stop your activities, remove your equipment from the body of water, and correct the source of the petroleum leak. You may not return your equipment to the water until the problem is corrected. You must store fuel and lubricants outside the frequent scour zone, and in the shade when possible.

(8) You may work within the wetted perimeter only from one-half hour before official sunrise to one-half hour after official sunset. If your mineral prospecting equipment exceeds one-half the width of the wetted perimeter of the stream, you must remove the equipment from the wetted perimeter or move it so that a minimum of fifty percent of the wetted perimeter is free of equipment between one-half hour after official sunset to one-half hour prior to official sunrise.

(9) You may not excavate, collect, or process aggregate within four hundred feet of any fishway, dam, or hatchery water intake.

(10) You must not disturb existing habitat improvement structures or stream channel improvements.

(11) You may not undermine, move, or disturb embedded large woody material. You may move large woody material and boulders that are not embedded, provided you return them as close to their original location as possible prior to abandoning the site or working another excavation site. You may not cut large woody material.

(12) You may not undermine, cut, or disturb live, rooted woody vegetation of any kind.

(13) Only one excavation site per individual is permitted. However, you may use a second excavation site as a settling

pond. Multiple individuals may work within a single excavation site.

(14) You must fill all excavation sites and level all tailing piles prior to working another excavation site or abandoning the excavation site.

(15) You may not excavate or collect aggregate from an unstable slope, the toe of the slope, or a portion of the slope that delivers, or has the potential to deliver, sediment to the wetted perimeter or frequent scour zone. See Figures 3 and 4.

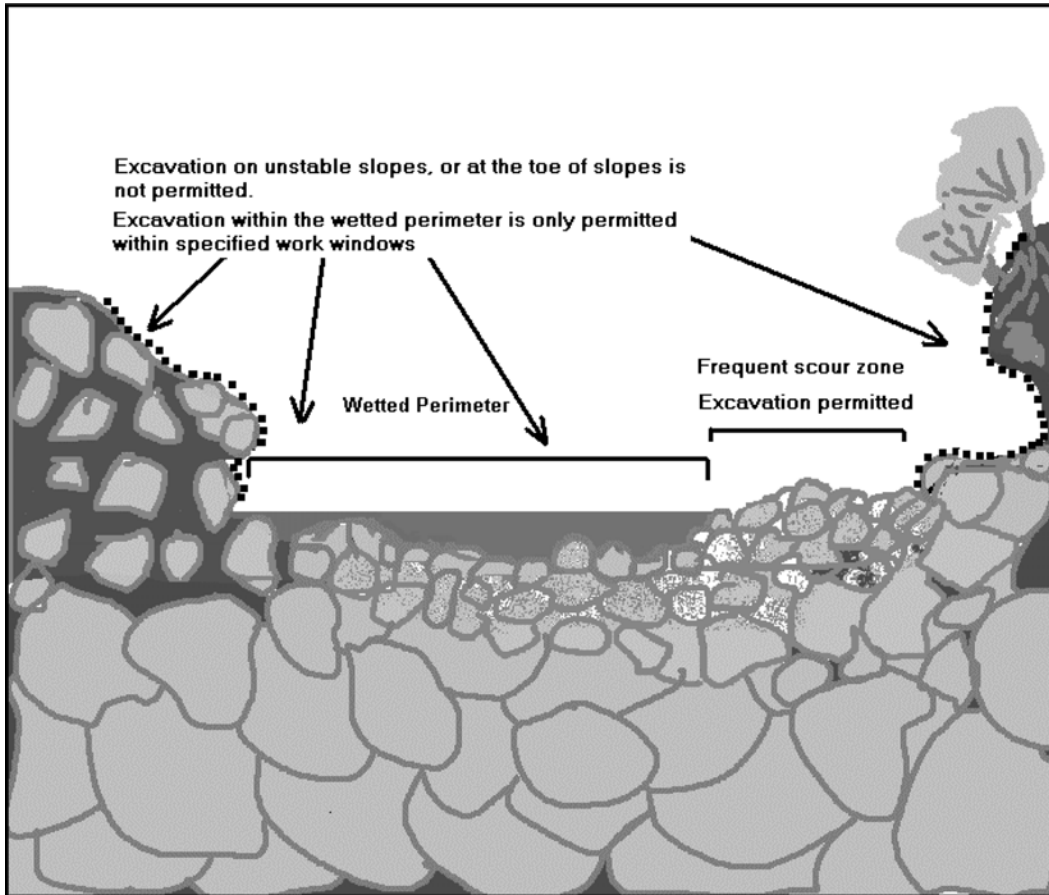

Figure 3: Cross section of a typical body of water showing unstable slopes, stable areas, and permissible or prohibited excavation sites under rules for mineral prospecting with timing restrictions. Dashed line indicates areas where excavation is not permitted.

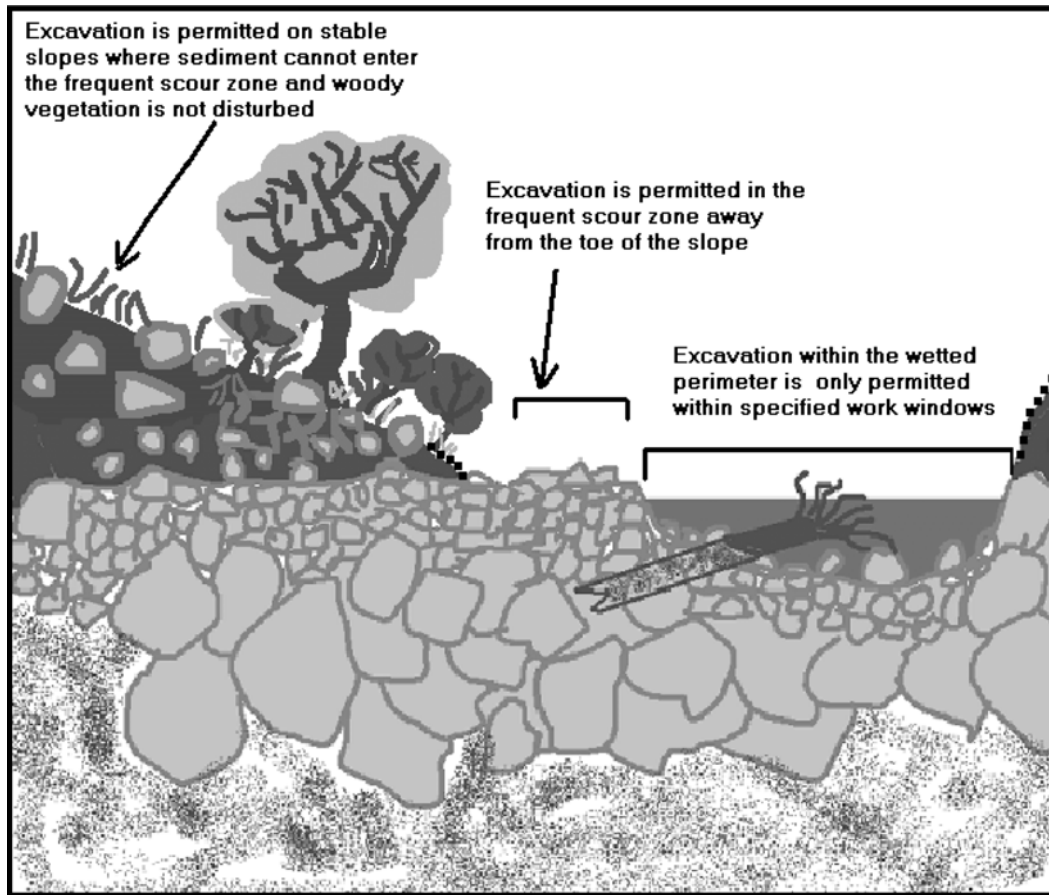

Figure 4: Permitted and prohibited excavation sites in a typical body of water under rules for mineral prospecting with timing restrictions. Dashed lines indicate areas where excavation is not permitted.

(16) You may partially divert a body of water into mineral prospecting equipment. However, at no time may the diversion structure be greater than fifty percent of the width of the wetted perimeter, including the width of the equipment. You may not divert the body of water outside of the wetted perimeter.

(17) You may use materials only from within the wetted perimeter, or artificial materials from outside the wetted perimeter, to construct the diversion structure. You must remove artificial materials used in the construction of a diversion structure and restore the site to its approximate original condition prior to abandoning the site.

(18) You may process aggregate collected from the frequent scour zone:

(a) At any location if you use pans; spiral wheels; or sluices, concentrators, rocker boxes, and high-bankers with riffle areas totaling ten square feet or less, including ganged equipment.

(b) Only in the frequent scour zone or upland areas landward of the frequent scour zone if you use power sluice/suction dredge combinations, high-bankers, or power sluices. You may not discharge tailings to the wetted perimeter when

using this equipment. However, you may discharge wastewater to the wetted perimeter as provided in subsection (5) of this section.

(19) You may process aggregate collected from upland areas landward of the frequent scour zone:

(a) At any location if you use pans; spiral wheels; or sluices, concentrators, mini rocker boxes, and mini high-bankers with riffle areas totaling three square feet or less, including ganged equipment. You must classify the aggregate at the excavation site prior to processing with this equipment within the wetted perimeter or frequent scour zone.

(b) Only at an upland location landward of the frequent scour zone if you use power sluice/suction dredge combinations; high-bankers; power sluices; or rocker boxes that have riffle areas totaling more than three, but less than ten, square feet. You may not allow tailings or wastewater to enter the wetted perimeter or frequent scour zone.

(c) Within the wetted perimeter or frequent scour zone with a sluice with a riffle area greater than three square feet. You must classify the aggregate at the excavation site prior to processing with a sluice with a riffle area exceeding three square feet.

(20) You may use pressurized water only for crevicing or for redistributing dredge tailings within the wetted perimeter. No other pressurized water use (jet or nozzle) is permitted.

(21) You may conduct crevicing in the wetted perimeter, in the frequent scour zone, or landward of the frequent scour zone. The hose connecting fittings of crevicing tools may not have an inside diameter larger than three-quarters of an inch. If you crevice landward of the frequent scour zone, you may not discharge sediment or wastewater to the wetted perimeter or the frequent scour zone.

(22) You must avoid areas containing live freshwater mussels. If you encounter live mussels during excavation, you must relocate your operations.

(23) You may not disturb redds. If you observe or encounter redds, or actively spawning fish when collecting or processing aggregate, you must relocate your operations.

(24) If at any time, as a result of project activities, you observe a fish kill or fish life in distress, you must immediately cease operations and notify the Washington department of fish and wildlife, and the Washington military department emergency management division of the problem. You may not resume work until the Washington department of fish and wildlife gives approval. The Washington department of fish and wildlife may require additional measures to mitigate the prospecting impacts.

AMENDATORY SECTION (Amending Order 98-252, filed 12/16/98, effective 1/16/99)

WAC 220-110-340 Informal appeal of adverse administrative decisions. It is recommended that an aggrieved party contact the local habitat biologist responsible for ~~((the hydraulic permit decision of concern))~~ granting or denying the HPA prior to initiating an informal or formal appeal. Discussion of concerns with the habitat biologist often results in resolution of the problem without the need for an informal or formal appeal. The habitat biologist may request review of your concerns by his or her supervisor.

All parties are encouraged to take advantage of ~~((this))~~ the informal appeal process prior to initiating a formal appeal. However, ~~((this))~~ the informal appeal process is not mandatory, and a person may proceed directly to a formal appeal.

(1) The following procedures shall govern informal appeals of department actions taken ~~((pursuant to))~~ under RCW ((75.20.100, 75.20.103, 75.20.106, and 75.20.160)) 77.55.021, 77.55.141, 77.55.151, 77.55.161(2), 77.55.181, and 77.55.291. This rule does not apply to the department's decisions regarding whether hydraulic projects qualify for processing under RCW 77.55.181, governing certain fish habitat enhancement projects. This rule also does not apply to any provisions or conditions in pamphlet(s) HPA or supplemental approvals as defined in WAC 220-110-020 ~~((44))~~ (52)(c) and (95). A person who disagrees with a provision or condition in a pamphlet HPA or its supplemental approval may apply for an individual, written HPA. A person who is aggrieved or adversely affected by the following department actions may request an informal ~~((review))~~ appeal:

(a) The denial or issuance of an HPA, or the conditions or provisions made part of an HPA; or

(b) An order imposing civil penalties.

(2) A request for an informal ~~((review))~~ appeal shall be in writing and shall be received by the department within thirty days of the denial or issuance of an HPA or receipt of an order imposing civil penalties. The thirty-day time requirement may be stayed by the department if negotiations are occurring between the aggrieved party and the habitat biologist and/or their supervisor. Requests for informal ~~((review))~~ appeal shall be mailed to HPA Appeals Coordinator, Department of Fish and Wildlife, Habitat ((and Lands Services)) Program, 600 Capitol Way, N., Olympia, Washington 98501-1091, or hand-delivered to 1111 Washington Street, S.E., Habitat ((and Lands Services)) Program, Fifth floor.

(3) The written request for an informal appeal shall be plainly labeled as "Request for Informal Appeal" and shall contain the following:

(a) The name, address, e-mail address (if available), and phone number of the person requesting the appeal;

(b) The specific agency action that the person contests, such as denial of an HPA, a particular condition in an HPA, or an order imposing civil penalties;

(c) Whether the person is the permittee, HPA applicant, landowner, resident, or other basis for the person's interest in the agency action in question;

(d) The date of denial, issuance, or condition of an HPA, or date the department issued the notice of civil penalty;

(e) Specific relief requested; and

(f) The attorney's name, address, e-mail address (if available) and phone number, if the person is represented by legal counsel.

(4) Upon receipt of a written request for informal ~~((agency review))~~ appeal, the department shall initiate a review of the agency decision. ~~((This review))~~ If agreed to by the appellant, and the appellant applied for the HPA, resolution of the appeal may be facilitated through an informal conference. The informal conference is a discussion between the appellant and the area habitat biologist mediated by the biologist's supervisor. The time period for the department to issue a decision on an informal appeal is suspended during the informal conference process. If resolution is not reached through the informal conference, the appellant is not the person who applied for the HPA, or the appeal involves an order imposing civil penalties, an informal appeal hearing shall be conducted by the ((regulatory services division manager or the division manager's)) HPA appeals coordinator or designee. Upon completion of the ((comprehensive review)) informal appeal hearing, the ((division manager)) HPA appeals coordinator, or designee shall recommend a decision to the director or the director's designee. This recommended decision shall be approved or disapproved by the director or the director's designee within sixty days of the date the informal appeal was received by the department, unless an extension of time is agreed to by the appellant. The department shall notify the appellant in writing of the decision of the director or the director's designee.

~~((4))~~ (5) If, following this informal ((agency review)) appeal process, the appellant still wishes to contest the agency action, a formal appeal may be initiated ((pursuant to)) under WAC 220-110-350. Formal review must be

requested within the time periods specified in WAC 220-110-350.

AMENDATORY SECTION (Amending Order 98-252, filed 12/16/98, effective 1/16/99)

WAC 220-110-350 Formal appeal of administrative decisions. (1) The following procedures shall govern formal appeals of department actions taken ~~((pursuant to))~~ under RCW ~~((75.20.100 or 75.20.106))~~ 77.55.021, except as indicated in RCW 77.55.301(5)(a), 77.55.151, 77.55.161(2), or 77.55.291. Subsection (2) of this section addresses appeals before the hydraulic appeals board. This rule does not apply to any provisions or conditions in pamphlets, or supplemental approvals as defined in WAC 220-110-020 ~~((44))~~ (52)(c) and (95). A person who disagrees with a provision or condition in a pamphlet HPA or its supplemental approval may apply for an individual, written HPA. ~~((This rule does not apply to an appeal in which a person contests the denial, conditioning or issuance of an HPA issued pursuant to RCW 75.20.103 or 75.20.160, which shall be heard by the hydraulic appeals board.))~~

(a) A person who is aggrieved or adversely affected by the following department actions may request a formal appeal:

~~((a))~~ (i) The denial or issuance of an HPA, or the conditions or provisions made part of an HPA;

~~((b))~~ (ii) An order imposing civil penalties; or

~~((c))~~ (iii) Any other ~~((agency action))~~ by the department's habitat program for which an adjudicative proceeding is required under the Administrative Procedure Act, chapter 34.05 RCW.

~~((d))~~ (b) As required by the Administrative Procedure Act, the department shall inform the permittee, HPA applicant or person subject to civil penalty ~~((order of the department, of the opportunity for appeal, the time within which to file a written request for an appeal, and the place to file it.~~

~~((e))~~ (c) A request for an appeal shall be in writing and shall be received during office hours by the department within thirty days of the agency action that is being challenged. Requests for appeal shall be mailed to HPA Appeals Coordinator, Department of Fish and Wildlife, Habitat ~~((and Lands Services))~~ Program, 600 Capitol Way, N., Olympia, Washington 98501-1091, or hand-delivered to 1111 Washington Street S.E., Habitat ~~((and Lands Services))~~ Program, Fifth floor. If there is no timely request for an appeal, the agency action shall be final and unappealable.

~~((f))~~ (d) The time period for requesting a formal appeal is suspended during consideration of a timely informal appeal. If there has been an informal appeal, the deadline for requesting a formal appeal shall be within thirty days of the date of the department's written decision in response to the informal appeal.

~~((g))~~ (e) The written request for an appeal shall be plainly labeled as "Request for Formal Appeal" and shall contain the following:

~~((h))~~ (i) The name, address, e-mail address (if available) and phone number of the person requesting the appeal;

~~((i))~~ (ii) The specific agency action that the person contests ~~((for example)), such as denial of an HPA, a particular condition in an HPA, an order imposing civil penalties, etc.;~~

~~((j))~~ (iii) Whether the person is the permittee, HPA applicant, landowner, resident, or other basis for the person's interest in the agency action in question;

~~((k))~~ (iv) The date of denial, issuance, or condition of an HPA, if the person is contesting denial, issuance, or conditioning of an HPA;

~~((l))~~ (v) Specific relief requested; and

~~((m))~~ (vi) The attorney's name, address, e-mail address (if available) and phone number, if the person is represented by legal counsel.

~~((n))~~ (f) The appeal may be conducted by the director, the director's designee, or by an administrative law judge (ALJ) appointed by the office of administrative hearings. If conducted by an ALJ, the ALJ shall issue an initial order ~~((pursuant to))~~ under RCW 34.05.461. The director or the director's designee shall review the initial order and enter a final order as provided by RCW 34.05.464.

~~((o))~~ (g) All hearings conducted by the director, the director's designee, or an ALJ ~~((pursuant to))~~ under subsection (6) of this section, shall comply with the Administrative Procedure Act and the model rules of procedure, chapter 10-08 WAC.

(2) The hydraulic appeals board hears appeals of the following permits:

(a) Under RCW 77.55.021 for the diversion of water for agricultural irrigation or stock watering purposes or when associated with streambank stabilization to protect farm and agricultural land as defined in RCW 84.34.020;

(b) Under RCW 77.55.241 for off-site mitigation proposals;

(c) Under RCW 77.55.141 for single family marine bulkheads or rockwalls;

(d) Under RCW 77.55.181 for fish habitat enhancement project HPA conditions or denials.

The appeal procedures for the board are found in WAC 259-04-060 and chapter 371-08 WAC.

AMENDATORY SECTION (Amending Order 94-160, filed 11/14/94, effective 12/15/94)

WAC 220-110-360 Penalties. (1) ~~((Any person that commences any activity subject to RCW 75.20.100, 75.20.103, or 75.20.160))~~ Under RCW 77.15.300, it is a gross misdemeanor to construct any form of hydraulic project or perform other work on a hydraulic project without having first obtained an HPA from the department, or ((any person that fails to comply with any of the requirements or provisions of an HPA, is guilty of a gross misdemeanor)), violate any requirements or conditions of the HPA for such construction or work.

(2) The department may impose a civil penalty of up to one hundred dollars per day for a violation ~~((or continuing violation))~~ of ~~((RCW 75.20.100 or 75.20.103, or any provision or condition of an HPA))~~ any provisions of RCW 77.55.021. The department shall impose the civil penalty with an order in writing delivered by certified mail or per-

sonal service to the person who is penalized. The notice shall describe the violation, identify the amount of the penalty, identify how to pay the penalty, and identify informal ~~((or))~~ and formal appeal rights for the person penalized. If the violation is an ongoing violation, the penalty shall accrue for each additional day of violation. For ongoing violations, the civil penalty may continue to accrue during any appeal process unless the accrual is stayed in writing by the department.

(3) If not timely appealed under WAC 220-110-340 or 220-110-350, the civil penalty order is final and unappealable. If appealed, the civil penalty becomes final upon issuance of a final order not subject to any further administrative appeal. When a civil penalty order becomes final, it is due and payable. If the civil penalty is not paid within thirty days after it becomes due and payable, the department may seek enforcement of the order ~~((pursuant to))~~ under RCW ~~((75.20.106))~~ 77.55.291 and 34.05.578.

REPEALER

The following sections of the Washington Administrative Code are repealed:

- WAC 220-110-203 Use of Class I mineral prospecting equipment.
- WAC 220-110-204 Use of Class II mineral prospecting equipment.
- WAC 220-110-205 Use of Class III mineral prospecting equipment.
- WAC 220-110-207 Authorized work times and watercourses for mineral prospecting and placer mining projects in the Columbia and Snake rivers, lakes, salt waters and waters within National Park boundaries using Class I and II equipment.
- WAC 220-110-208 Authorized work times and watercourses for mineral prospecting and placer mining projects using Class III equipment only.
- WAC 220-110-209 Authorized work times and watercourses for mineral prospecting and placer mining projects using Class 0 equipment only.

WSR 08-01-085

PROPOSED RULES

DEPARTMENT OF

SOCIAL AND HEALTH SERVICES

(Health and Recovery Services Administration)

[Filed December 17, 2007, 11:25 a.m.]

Original Notice.

Preproposal statement of inquiry was filed as WSR 07-21-030.

Title of Rule and Other Identifying Information: The department is amending WAC 388-501-0135 Patient review and restriction program (PRR).

Hearing Location(s): Office Building 2 - Auditorium (DSHS Headquarters), 1115 Washington, Olympia, WA 98504 (public parking at 11th and Jefferson. A map is available at <http://www1.dshs.wa.gov/msa/rpau/RPAU-OB-2directions.html> or by calling (360) 664-6094), on January 22, 2008, at 10:00 a.m.

Date of Intended Adoption: Not earlier than January 23, 2008.

Submit Written Comments to: DSHS Rules Coordinator, P.O. Box 45850, Olympia, WA 98504-5850, delivery 4500 10th Avenue S.E., Lacey, WA 98503, e-mail DSHS RPAURulesCoordinator@dshs.wa.gov, fax (360) 664-6185, by 5 p.m. on January 22, 2008.

Assistance for Persons with Disabilities: Contact Jenisha Johnson, DSHS Rules Consultant, by January 15, 2008, TTY (360) 664-6178 or (360) 664-6094 or by e-mail at johnsj14@dshs.wa.gov.

Purpose of the Proposal and Its Anticipated Effects, Including Any Changes in Existing Rules: The rule is being amended to: (1) Change program name to patient review and coordination (PRC) program, (2) expand program definitions, (3) clarify restrictions, (4) add a requirement that the PRC clients remain enrolled in the managed care plans for one year, and (5) clarify client dispute resolution process.

Reasons Supporting Proposal: This revision provides added clarification, changes the program name to reflect program coordination activities, and adds a new program placement requirement to provide continuity of care coordination.

Statutory Authority for Adoption: RCW 74.08.090, 42 C.F.R. 431.51, 431.54(e) and 456.1, 42 U.S.C. 1396N.

Statute Being Implemented: RCW 74.08.090, 42 C.F.R. 431.51, 431.54(e) and 456.1, 42 U.S.C. 1396N.

Rule is necessary because of federal law, 42 C.F.R. 431.51, 431.54(e) and 456.1, 42 U.S.C. 1396N.

Name of Proponent: Department of social and health services, governmental.

Name of Agency Personnel Responsible for Drafting: Jonell O. Blatt, 626 8th Avenue, Olympia, WA 98504, (360) 725-1571; Implementation and Enforcement: Trang T. Kuss, 626 8th Avenue, Olympia, WA 98504, (360) 725-1391.

No small business economic impact statement has been prepared under chapter 19.85 RCW. The revision to this rule does not affect small businesses.

A cost-benefit analysis is required under RCW 34.05.328. A preliminary cost-benefit analysis may be obtained by contacting Trang Kuss, P.O. Box 45532, Olym-

pia, WA 98504-5532, phone (360) 725-1391, fax (360) 725-1969, e-mail kusstt@dshs.wa.gov.

December 13, 2007
Stephanie E. Schiller
Rules Coordinator

AMENDATORY SECTION (Amending WSR 06-14-062, filed 6/30/06, effective 7/31/06)

WAC 388-501-0135 Patient review and ((restriction (PRR))) coordination (PRC). (1) **Patient review and ((restriction (PRR)))** ((is a health and safety program for medical assistance fee-for-service clients and managed care organization (MCO) enrollees needing help with using medical services appropriately. PRR is authorized under federal Medicaid law by 42 USC 1396n (a)(2) and 42 CFR 431.54)) **coordination (PRC)** program, formerly known as the patient review and restriction (PRR) program, coordinates care and ensures that clients selected for enrollment in PRC use services appropriately and in accordance with department rules and policies.

(a) PRC applies to medical assistance fee-for-service and managed care clients. PRC does not apply to clients eligible for the family planning only program.

(b) PRC is authorized under federal Medicaid law by 42 USC 1396n (a)(2) and 42 CFR 431.54.

(2) **Definitions.** The following definitions apply to this section only:

"Appropriate use" ((means)) - Use of ((health care)) healthcare services that are adapted to or appropriate for a client's ((or enrollee's medical)) healthcare needs.

"Assigned provider" ((means)) - A department-enrolled healthcare provider or one participating with a department contracted managed care organization (MCO) ((contracted medical provider)) who agrees to be assigned as a primary provider and coordinator of services for a ((medical assistance)) fee-for-service or managed care client ((or MCO enrollee)) in the ((PRR)) PRC program. Assigned providers can include a primary care provider (PCP), a pharmacy, a ((narcotic)) controlled substances prescriber, and((-) a hospital for ((nonemergency medical)) nonemergent hospital services((-, a hospital)).

"At-risk" ((means a medical history that may include)) - A term used to describe one or more of the following:

(a) A client with a medical history of:

- ((Indicators)) Indications of forging or altering prescriptions;

- Seeking and/or obtaining ((medical)) healthcare services at a frequency or amount that is not medically necessary;

- ((Indicators of potentially)) Potential life-threatening events or life-threatening conditions that required or may require medical intervention((-

- A client's or enrollee's medical assistance identification card reportedly used by an unauthorized person(s) or for an unauthorized purpose(s); or

•))

(b) ((Other)) Behaviors or practices that could jeopardize a client's ((or enrollee's)) medical treatment or health including, but not limited to:

- Referrals from social services personnel about inappropriate behaviors or practices that places the client at risk;

- Noncompliance with treatment;

- Paying cash for controlled substances;

- Positive urine drug screen for illicit street drugs or non-prescribed controlled substances; or

- Unauthorized use of a client's medical assistance identification card or for an unauthorized purpose.

"Care management" - Services provided to clients with multiple health, behavioral, and social needs in order to improve care coordination, client education, and client self-management skills.

"Client" - A person enrolled in a department healthcare program and receiving service from fee-for-service provider(s) or a managed care organization (MCO), contracted with the department.

"Conflicting" ((means)) - Drugs and/or ((health care)) healthcare services that are incompatible and/or unsuitable for use together because of undesirable chemical or physiological effects.

"Contraindicated" ((means)) - To indicate or show ((that)) a medical treatment or procedure is inadvisable or not recommended or warranted.

"Controlled substances prescriber" - Any of the following healthcare professionals who, within their scope of professional practice, are licensed to prescribe and administer controlled substances (see chapter 69.50 RCW, uniform controlled substance act) for a legitimate medical purpose:

- A physician under chapter 18.71 RCW;

- A physician assistant under chapter 18.71A RCW;

- An osteopathic physician under chapter 18.57 RCW;

- An osteopathic physician assistant under chapter 18.57A RCW; and

- An advanced registered nurse practitioner under chapter 18.79 RCW.

"Duplicative" - Applies to the use of the same or similar drugs and ((health care)) healthcare services without due justification. Example: A client ((or MCO enrollee)) receives ((health care)) healthcare services from two or more providers for the same or similar condition(s) in an overlapping time frame, or the client receives two or more similarly acting drugs in an overlapping time frame, which could result in a harmful drug interaction or an adverse reaction.

"Just cause" - A legitimate reason to justify the action taken, including but not limited to, protecting the health and safety of the client.

"Managed care organization" or "MCO" ((means)) - An organization having a certificate of authority or certificate of registration from the office of insurance commissioner, that contracts with the department under a comprehensive risk contract to provide prepaid ((health care)) healthcare services to eligible medical assistance clients under the department's managed care programs.

"((MCO enrollee)) Managed care client" ((means)) - A medical assistance client enrolled in, and receiving ((medical)) healthcare services from, a department-contracted managed care organization (MCO).

"((Narcotic prescriber" means any of the following health care professionals who, within their scope of professional practice, are licensed to prescribe and administer con-

controlled substances (see chapter 69.50 RCW, Uniform Controlled Substance Act) for a legitimate medical purpose:

- A physician under chapter 18.71 RCW;
- A physician assistant under chapter 18.71A RCW;
- An osteopathic physician under chapter 18.57 RCW;
- An osteopathic physician assistant under chapter 18.57A RCW; and
- An advanced registered nurse practitioner under chapter 18.79 RCW.)

"Primary care provider" or "PCP" ((means)) - A person licensed or certified under title 18 RCW including, but not limited to, a physician, an advanced registered nurse practitioner (ARNP), or a physician assistant who supervises, coordinates, and provides ((health care)) healthcare services to a client ((or an MCO enrollee)), initiates referrals for specialty and ancillary care, and maintains the client's ((or enrollee's)) continuity of care.

(3) ~~((Restrictions under the PRR program:~~

~~(a) Do not apply to a client eligible for a family planning only program; and~~

~~(b) Do apply to a fee-for-service client or an MCO enrollee currently assigned to the PRR program))~~ **Clients selected for PRC review.** The department or MCO selects a client for PRC review when either or both of the following occur:

(a) A utilization review report indicates the client has not utilized healthcare services appropriately; or

(b) Medical providers, social service agencies, or other concerned parties have provided direct referrals to the department or MCO.

(4) **When a fee-for-service client is selected for PRC review** the prior authorization process ~~((described in WAC 388-530-1250))~~ as defined in chapter 388-530 WAC may be required ~~((for a fee-for-service client))~~:

(a) Prior to or during a ((PRR)) PRC review; or

(b) When currently ((placed)) in the ((PRR)) PRC program.

(5) ~~((Clients selected for PRR review. The department or MCO selects a fee-for-service client or MCO enrollee for PRR review when either or both of the following occur:~~

~~(a) A utilization review report indicates the client or enrollee has utilized health care services as described in subsection (6) of this section; or~~

~~(b) Medical providers, social service agencies, or other concerned parties have provided direct referrals to the department or MCO.~~

~~((6))~~ **((PRR)) Review for placement in the ((PRR)) PRC program.** When the department or MCO selects a client ((or enrollee)) for ((PRR)) PRC review, the department or MCO staff, with clinical oversight, reviews a client's ((or enrollee's)) medical and/or billing history to determine if the client ((or enrollee)) has utilized ((medical)) healthcare services at a frequency or amount that is not medically necessary (42 CFR 431.54(e)). ~~((The utilization guidelines in subsection (7) of this section establish that a client or enrollee has utilized medical services at a frequency or amount that is not medically necessary when:~~

~~(a) There is a history of medical services that are duplicative, excessive, or contraindicated;~~

~~(b) There is a history of conflicting health care services, drugs, or supplies that are not within acceptable medical practice; or~~

~~(c) The medical history shows indicators of "at-risk" utilization patterns.~~

~~((7))~~ **(6) Utilization guidelines for ((PRR)) PRC placement.** Department ((and)) or MCO staff use the following utilization guidelines to determine ((PRR)) PRC placement ((and)). A client may be placed ((a client or enrollee)) in the ((PRR)) PRC program when medical and/or billing histories document any of the following:

(a) Any two or more of the following conditions occurred in a period of ninety consecutive calendar days in the previous twelve months. The client ((or enrollee)):

(i) Received services from four or more different providers, including physicians, advanced registered nurse practitioners (ARNPs), and physician assistants (PAs);

(ii) Had prescriptions filled by four or more different pharmacies;

(iii) Received ten or more prescriptions;

(iv) Had prescriptions written by four or more different prescribers;

(v) Received similar services from two or more providers in the same day; or

(vi) Had ten or more office visits.

(b) Any one of the following occurred within a period of ninety consecutive calendar days in the previous twelve months. The client ((or enrollee has)):

(i) Made two or more emergency department visits;

(ii) Has a medical history that indicates "at-risk" utilization patterns;

(iii) Made repeated and documented efforts to seek ((health care)) healthcare services that are not medically necessary; or

(iv) Has been counseled at least once by a health care provider, or a department or MCO staff member, with clinical oversight, about the appropriate use of ((health care)) healthcare services.

(c) The client ((or enrollee)) received prescriptions for controlled substances from two or more different prescribers in any one month in the previous twelve months.

(d) The client's medical and/or billing history demonstrates a pattern of the following at any time within a one-year period:

(i) The client has a history of using healthcare services in a manner that is duplicative, excessive, or contraindicated; or

(ii) The client has a history of receiving conflicting healthcare services, drugs, or supplies that are not within acceptable medical practice.

~~((8))~~ **(7) ((PRR)) PRC review ((outcomes)) results.** As a result of the ((PRR)) PRC review, the department or MCO staff may take any of the following steps:

(a) Determine that no action is needed and close the client's ((or enrollee's)) file;

(b) Send the client ((or enrollee)) and, if applicable, the client's ((or enrollee's)) authorized representative, a letter of concern with information on specific findings and notice of potential placement in the ((PRR)) PRC program; or

(c) Determine that the utilization guidelines for ((PRR)) PRC placement establish that the client ((or enrollee)) has

utilized ~~((medical))~~ healthcare services at an amount or frequency that is not medically necessary ~~((and))~~, in which case the department or MCO will take one or more of the following actions~~((The department or MCO staff))~~:

(i) Refer~~((s))~~ the client ~~((or enrollee))~~ for education on appropriate use of ~~((health care))~~ healthcare services;

(ii) Refer~~((s))~~ the client ~~((or enrollee))~~ to other support services or agencies; or

(iii) Place~~((s))~~ the client ~~((or enrollee))~~ into the ~~((PRR))~~ PRC program for an initial ~~((restriction))~~ placement period of twenty-four months.

~~((9))~~ **(8) ((PRR)) Initial placement in the PRC program ((placement))**. When a ~~((fee-for-service))~~ client ~~((or MCO enrollee))~~ is initially placed in the ~~((PRR))~~ PRC program~~((, the department or the MCO sends the client or enrollee and, if applicable, the client's or enrollee's authorized representative, a written notice of the PRR placement that:~~

~~((a))~~ informs the client or the enrollee of the reason for the PRR program placement.

~~((b))~~ Restricts:

~~((a))~~ The department or MCO places the client ((or enrollee)) for twenty-four months ((to)) with one or more of the following types of ((providers when obtaining health care services)) healthcare providers:

(i) Primary care ~~((physician))~~ provider (PCP) (as defined in subsection (2) of this section);

(ii) Pharmacy;

(iii) ~~((Narcotic))~~ Controlled substances prescriber;

(iv) Hospital (for ~~((nonemergency medical))~~ nonemergency hospital services); or

(v) Another qualified ~~((provider type))~~ provider type, as determined by department or MCO program staff on a case-by-case basis.

~~((e))~~ Directs the client or enrollee to respond to the department or the MCO within ten days of the date of the written notice:

~~((i))~~ To select providers, subject to department or MCO approval;

~~((ii))~~ To submit additional medical information, justifying the client's or enrollee's use of medical services; or

~~((iii))~~ To request assistance, if needed, from the department or MCO program staff.

~~((d))~~ Informs the client or enrollee of hearing rights (see subsection (14) of this section).

~~((e))~~ Informs the client or enrollee that if a response is not received within ten days of the date of the notice, the client or enrollee will be assigned providers.

~~((f))~~ Informs the client or enrollee of the rules that support the decision) (b) The managed care client will remain in the same MCO for no less than twelve months unless:

(i) The client moves to a residence outside the MCO's service area and the MCO is not available in the new location; or

(ii) The client's assigned provider no longer participates with the MCO and is available in another MCO, and the client wishes to remain with the current provider.

(c) A managed care client placed in the PRC program must remain in the PRC program for the initial twenty-four month period regardless of whether the client changes MCOs or becomes a fee-for-service client.

(d) A care management program may be offered to a client.

(9) Notifying the client about placement in the PRC program. When the client is initially placed in the PRC program, the department or the MCO sends the client and, if applicable, the client's authorized representative, a written notice containing at least the following components:

(a) Informs the client of the reason for the PRC program placement;

(b) Directs the client to respond to the department or MCO within ten business days of the date of the written notice about taking the following actions:

(i) Select providers, subject to department or MCO approval;

(ii) Submit additional healthcare information, justifying the client's use of healthcare services; or

(iii) Request assistance, if needed, from the department or MCO program staff.

(c) Informs the client of hearing or appeal rights (see subsection (14) of this section).

(d) Informs the client that if a response is not received within ten days of the date of the notice, the client will be assigned a provider(s) by the department or MCO.

(10) Selection and role of assigned provider. A ~~((fee-for-service))~~ client ~~((and an MCO enrollee))~~ may be afforded a limited choice of providers ~~((for the types of services that are to be restricted (see subsection (9)(a) of this section for a list of provider types that the department may assign))~~.

(a) The following providers are not available:

(i) A provider who is being reviewed by the department or licensing authority regarding quality of care;

(ii) A provider who has been suspended or disqualified from participating as a department-enrolled or MCO-contracted provider; or

(iii) A provider whose business license is suspended or revoked by the licensing authority.

(b) For a ((fee-for-service)) client placed in the ((PRR)) PRC program, the assigned:

(i) Provider(s) must be located in the client's local geographic area, in the client's selected MCO, and/or be reasonably accessible to the client.

(ii) ((Department-enrolled)) Primary care provider (PCP) supervises and coordinates ((health care)) healthcare services for the client, including ((providing)) continuity of care and referrals to specialists when necessary. The PCP must be one of the following:

(A) A physician who meets the criteria ((under WAC 388-502-0020 and 388-502-0030)) as defined in chapter 388-502 WAC;

(B) An advanced registered nurse practitioner (ARNP) who meets the criteria ((under WAC 388-502-0020 and 388-502-0030)) as defined in chapter 388-502 WAC; or

(C) A licensed physician assistant (PA), practicing with a ((sponsored)) supervising physician.

(iii) ((Narcotic)) Controlled substances prescriber prescribes all controlled substances for the client.

(iv) Pharmacy fills all prescriptions for the client.

(v) Hospital provides all ((nonemergency and outpatient hospital care for the client)) nonemergent hospital services.

~~((b) For an MCO enrollee placed in the PRR program, the assigned PCP, narcotic prescriber, pharmacy, and hospital must be:~~

- ~~(i) Available within the enrollee's selected MCO; and~~
- ~~(ii) Located in the enrollee's local geographic area and/or reasonably accessible to the enrollee.)~~

(c) A client ~~((or enrollee))~~ placed in the ~~((PRR))~~ PRC program cannot change assigned providers for twelve months after the assignments are made, unless:

- (i) The client ~~((or enrollee))~~ moves to a residence outside the provider's geographic area;
- (ii) The provider moves out of the client's ~~((or enrollee's))~~ local geographic area and is no longer reasonably accessible to the client ~~((or enrollee))~~;
- (iii) The provider refuses to continue to serve the client ~~((or enrollee))~~;
- (iv) The client ~~((or enrollee))~~ did not select the provider. The client ~~((or enrollee))~~ may request to change an assigned provider once within thirty calendar days of the initial assignment;

(v) The ~~((enrollee's))~~ client's assigned provider no longer participates with the MCO. In this case, the ~~((enrollee))~~ client may select a new provider from the list of available providers in the MCO or ~~((transfer enrollment of all family members to the new department contracted MCO that the established provider has joined;~~

~~(vi) The provider has been suspended or disqualified from participating as a department-enrolled or MCO-contracted provider; or~~

~~(vii) The provider's business license has been suspended or revoked by the licensing authority;))~~ follow the assigned provider to the new MCO.

(d) When an assigned prescribing provider no longer contracts with the department:

- (i) All prescriptions from the provider are invalid thirty calendar days following the date the contract ends; and
- (ii) All prescriptions from the provider are subject to applicable ~~((pharmacy))~~ prescription drugs (outpatient) rules in chapter 388-530 WAC or appropriate MCO rules~~((; and))~~;
- (iii) The client ~~((or enrollee))~~ must choose or be assigned another provider according to the requirements in this section.

(11) ~~((PRR restriction))~~ PRC placement periods. The length of time for a ~~((fee-for-service))~~ client's ~~((or MCO enrollee's))~~ PRC placement includes:

(a) The initial ~~((restriction))~~ period of ~~((PRR))~~ PRC placement, which is:(=

- ~~(i) A minimum of twenty-four consecutive months; or~~
- ~~(ii) If the client or enrollee is not eligible for a medical assistance program for any month(s) during the span of the twenty-four consecutive months of PRR placement, the restriction period is for the duration of the client's or enrollee's medical assistance program eligibility plus any subsequent period of eligibility up to but not exceeding twenty-four months;))~~ a minimum of twenty-four consecutive months.

(b) The second ~~((restriction))~~ period of ~~((PRR))~~ PRC placement, which is:(=

- (i) An additional thirty-six consecutive months; or

~~(ii) If the client or enrollee is not eligible for a medical assistance program for any month(s) during the span of the thirty-six consecutive months, the restriction period is for the duration of the client's or enrollee's eligibility for a medical assistance program plus any subsequent period of eligibility up to but not exceeding thirty-six months; and))~~ an additional thirty-six consecutive months.

(c) The third ~~((restriction))~~ period and each subsequent period of ~~((PRR))~~ PRC placement, which is:(=

- ~~(i) An additional seventy-two consecutive months; or~~
- ~~(ii) If the client or enrollee is not eligible for a medical assistance program for any month(s) during the span of the seventy-two consecutive months, the restriction period is for the duration of the client's or enrollee's eligibility for a medical assistance program plus any subsequent period of eligibility up to but not exceeding each seventy-two month placement))~~ an additional seventy-two months.

(12) Department review of a ~~((PRR restriction))~~ PRC placement period ~~((assignment))~~. The department ~~or MCO~~ reviews a ~~((fee-for-service))~~ client's ~~((or MCO enrollee's))~~ use of ~~((health care))~~ healthcare services prior to the end of each ~~((assigned PRR restriction))~~ PRC placement period described in subsection (11) of this section using the utilization guidelines in subsection ~~((7))~~ (6) of this section.

(a) The department ~~or MCO~~ assigns the next ~~((PRR restriction))~~ PRC placement period if the utilization guidelines for ~~((PRR))~~ PRC placement in subsection ~~((7))~~ (6) apply to the client ~~((or enrollee))~~.

(b) When the department ~~or MCO~~ assigns a subsequent ~~((PRR restriction))~~ PRC placement period, the department ~~or MCO~~ sends the client ~~((or enrollee))~~ and, if applicable, the client's ~~((or enrollee's))~~ authorized representative, a written notice ~~((that informs))~~ informing the client ~~((or enrollee))~~:

- (i) ~~((f))~~ The reason for the subsequent ~~((PRR))~~ PRC program placement;
- (ii) ~~((f))~~ The ~~((period of time))~~ length of the subsequent ~~((PRR))~~ PRC placement;
- (iii) That the current providers assigned to the client ~~((or enrollee))~~ continue to be assigned to the client during the subsequent ~~((PRR restriction))~~ PRC placement period;
- (iv) That all ~~((PRR))~~ PRC program rules continue to apply; and
- (v) Of hearing or appeal rights (see subsection (14) of this section); ~~((and))~~
- (vi) Of the rules that support the decision.

(c) The department may ~~((lift any assigned PRR restriction period))~~ remove a client from PRC placement if the client ~~((or enrollee))~~:

- (i) Successfully completes a treatment program that is provided by a chemical dependency service provider certified by the department under chapter 388-805 WAC;
- (ii) Submits documentation of completion of the approved treatment program to the department; and
- (iii) Maintains appropriate use of ~~((health care))~~ healthcare services within the utilization guidelines described in subsection ~~((7))~~ (6) for six months after the date the treatment ends.

(d) ~~((A client or enrollee who is placed in the PRR program after being removed from any PRR restriction period will be placed at the next PRR restriction period described in~~

subsections ~~(11)(b) and (c)~~ of this section)) The department or MCO determines the appropriate placement period for a client who has been placed back into the program.

(e) A client ~~((or enrollee))~~ will remain placed in the ~~((PRR))~~ PRC program regardless of change in eligibility program type or change in address.

(13) **Client financial responsibility.** ~~((This subsection takes precedence over WAC 388-502-0160.))~~ A ~~((fee-for-service))~~ client ~~((or MCO enrollee))~~ placed in the ~~((PRR))~~ PRC program may be billed by a provider and held financially responsible for ~~((health care))~~ healthcare services when the client ~~((or enrollee))~~ obtains ~~((nonemergency))~~ nonemergency services and the provider who renders the services is not assigned or referred under the ~~((PRR))~~ PRC program.

(14) **Right to hearing or appeal.**

(a) A fee-for-service client ~~((or MCO enrollee))~~ who believes the department ~~((or MCO))~~ has taken an invalid action ~~((erroneously))~~ pursuant to this section may request a hearing.

(b) A managed care client who believes the MCO has taken an invalid action pursuant to this section or chapter 388-538 WAC must exhaust the MCO's internal appeal process set forth in WAC 388-538-110 prior to requesting a hearing. Managed care clients can not change MCOs until the appeal or hearing is resolved and there is a final ruling.

~~((a))~~ (c) A client ~~((or enrollee))~~ must request the hearing or appeal within ninety calendar days after the client ~~((or enrollee))~~ receives the written notice of ~~((restriction))~~ placement in the PRC program. ~~((Chapter 388-538 WAC does not apply to the department's or MCO's decision to place an enrollee in the PRC program.~~

~~((b))~~ (d) The department conducts a hearing according to chapter 388-02 WAC. Definitions for the terms "hearing," "initial order," and "final order" used in this subsection are found in WAC 388-02-0010.

~~((c))~~ (e) A client ~~((or enrollee))~~ who requests a hearing or appeal within ten calendar days from the date of the written notice of an initial ~~((restriction))~~ PRC placement period ~~((of PRR placement))~~ under subsection (11)(a) of this section will not be placed in the ~~((PRR))~~ PRC program until the date an initial order is issued that supports the client's ~~((or enrollee's))~~ placement in the ~~((PRR))~~ PRC program or otherwise ordered by an administrative law judge (ALJ).

~~((d))~~ (f) A client ~~((or enrollee))~~ who requests a hearing ~~((after))~~ or appeal more than ten calendar days from the date of the written notice under subsection ~~((11)(a))~~ (9) of this section will remain placed in the ~~((PRR))~~ PRC program unless a final administrative order is entered that orders ~~((their))~~ the client's removal from ~~((restriction))~~ the program.

~~((e))~~ (g) A client ~~((or enrollee))~~ who requests a hearing or appeal within ninety days from the date of receiving the written notice under subsection ~~((11)(b) or (c) or)~~ (9) of this section and who has already been assigned providers will remain placed in the ~~((PRR))~~ PRC program unless a final administrative order is entered that orders the client's ~~((or enrollee's))~~ removal from ~~((restriction))~~ the program.

~~((f))~~ (h) An administrative law judge (ALJ) may rule that the client ~~((or enrollee))~~ be placed in the ~~((PRR))~~ PRC program prior to the date the record is closed and prior to the date the initial order is issued based on a showing of just

cause ~~((a showing of just cause means it has been demonstrated that there is a legitimate cause to justify the action taken) to protect the health and safety of the client or enrollee).~~

(i) The client who requests a hearing challenging placement into the PRC program has the burden of proving the department's or MCO's action was invalid. For standard of proof, see WAC 388-02-0485.

Reviser's note: The typographical error in the above section occurred in the copy filed by the agency and appears in the Register pursuant to the requirements of RCW 34.08.040.

WSR 08-01-086

**PROPOSED RULES
DEPARTMENT OF**

SOCIAL AND HEALTH SERVICES

(Aging and Disability Services Administration)

[Filed December 17, 2007, 11:26 a.m.]

Original Notice.

Preproposal statement of inquiry was filed as WSR 07-09-046.

Title of Rule and Other Identifying Information: The department is amending WAC 388-825-103 When will I receive written notice of decisions made by DDD? and 388-825-145 Will my benefits continue if I request an administrative hearing?

Hearing Location(s): Office Building 2 - Auditorium (DSHS Headquarters), 1115 Washington, Olympia, WA 98504 (public parking at 11th and Jefferson. A map is available at <http://www1.dshs.wa.gov/msa/rpau/RPAU-OB-2directions.html> or by calling (360) 664-6094), on January 22, 2008, at 10:00 a.m.

Date of Intended Adoption: Not earlier than January 23, 2008.

Submit Written Comments to: DSHS Rules Coordinator, P.O. Box 45850, Olympia, WA 98504, delivery 4500 10th Avenue S.E., Lacey, WA 98503, e-mail DSHSRULES.COORDINATOR@dshs.wa.gov, fax (360) 664-6185, by 5 p.m. on January 22, 2008.

Assistance for Persons with Disabilities: Contact Jenisha Johnson, DSHS Rules Consultant, by January 15, 2008, TTY (360) 664-6178 or (360) 664-6094 or by e-mail at johnsjl4@dshs.wa.gov.

Purpose of the Proposal and Its Anticipated Effects, Including Any Changes in Existing Rules: The purpose of these amendments is to revise WAC 388-825-103 and 388-825-145 to comply with the proposed order and settlement agreement under *Boyle v. Arnold-Williams*. The amendments add language regarding disenrollment from a DDD home and community based services waiver to the notice requirements and to the continuance of benefits pending an administrative hearing. When effective, these rules replace the emergency rules filed as WSR 07-23-012. The department intends to adopt further rules in chapter 388-825 WAC at a future date.

Reasons Supporting Proposal: These rules are necessary to comply with the proposed order and settlement agreement under *Boyle v. Arnold-Williams*.

Statutory Authority for Adoption: RCW 71A.12.030.

Statute Being Implemented: Title 71A RCW.

Rule is necessary because of federal court decision, *Boyle vs. Arnold-Williams*, the United States District Court for the Western District of Washington, No. C-01-5687 JKA.

Name of Proponent: Department of social and health services, governmental.

Name of Agency Personnel Responsible for Drafting: Steve Brink, 640 Woodland Square Loop S.E., Lacey, WA 98503-1045, P.O. Box 45310, Olympia, WA 98507-5310, e-mail brinksc@dshs.wa.gov, (360) 725-3416, fax (360) 404-0955; Implementation: Shannon Manion, 640 Woodland Square Loop S.E., Lacey, WA 98503-1045, P.O. Box 45310, Olympia, WA 98507-5310, e-mail maniosk@dshs.wa.gov, (360) 725-3454, fax (360) 404-0955; and Enforcement: Don Clintsman, 640 Woodland Square Loop S.E., Lacey, WA 98503-1045, P.O. Box 45310, Olympia, WA 98507-5310, e-mail clintsd@dshs.wa.gov, (360) 725-3421, fax (360) 404-0955.

No small business economic impact statement has been prepared under chapter 19.85 RCW. These rules do not impact small business.

A cost-benefit analysis is not required under RCW 34.05.328. These rules are not considered "significant." The rules are procedural as they pertain to the requirements related to agency hearings. Therefore they are exempt from the requirement to prepare a cost-benefit analysis.

December 13, 2007
Stephanie E. Schiller
Rules Coordinator

AMENDATORY SECTION (Amending WSR 05-11-015, filed 5/9/05, effective 6/9/05)

WAC 388-825-103 When will I receive written notice of decisions made by DDD? You will receive written notice from DDD of the following decisions:

(1) The denial or termination of eligibility for services under WAC 388-825-030 and 388-825-035;

(2) The authorization, denial, reduction, or termination of services or the payment of SSP set forth in chapter 388-827 WAC that are authorized by DDD;

(3) The admission or readmission to, or discharge from a residential habilitation center.

(4) Disenrollment from a DDD home and community based services waiver under WAC 388-845-0060, including a disenrollment from a waiver and enrollment in a different waiver.

AMENDATORY SECTION (Amending WSR 06-10-055, filed 5/1/06, effective 6/1/06)

WAC 388-825-145 Will my benefits continue if I request an administrative hearing? (1) If you request an administrative hearing regarding the department's decision to transfer you from a residential habilitation center to the community under RCW 71A.20.080, the rules in WAC 388-825-155 apply.

(2) If you request an administrative hearing within the ten-day notice period, as described in chapter 388-458 WAC, unless one or more of the conditions in WAC 388-825-150

applies, the department will take no action until there is a final decision on your appeal of the department's decision to:

(a) Terminate your eligibility for services;

(b) Reduce or terminate your services; (~~(c)~~)

(c) Reduce or terminate the payment of SSP set forth in chapter 388-827 WAC; or

(d) Disenroll you from a DDD home and community based services waiver under WAC 388-845-0060, including a disenrollment from a waiver and enrollment in a different waiver.

(3) The department will take no action until there is a final decision on your appeal of the department's decision to remove or transfer you to another residential service unless one or more of the conditions in WAC 388-825-150 applies.

(4) The department will take no action to terminate your provider of choice unless one or more of the circumstances described in WAC 388-825-150 applies.

(5) After the administrative hearing, you may have to pay back continued benefits you get, as described in chapter 388-410 WAC, if the administrative hearing decision is in favor of the department.

WSR 08-01-089

PROPOSED RULES

DEPARTMENT OF

SOCIAL AND HEALTH SERVICES

(Aging and Disability Services Administration)

[Filed December 17, 2007, 11:30 a.m.]

Original Notice.

Preproposal statement of inquiry was filed as WSR 07-13-059.

Title of Rule and Other Identifying Information: The department is amending WAC 388-106-0020 Under the MPC (medicaid personal care), COPES (community options program entry system), MNRW (medically needy residential waiver), MNIW (medically needy in-home waiver), and chore programs, what services are not covered?

Hearing Location(s): Office Building 2 - Auditorium (DSHS Headquarters), 1115 Washington, Olympia, WA 98504 (public parking at 11th and Jefferson. A map is available at <http://www1.dshs.wa.gov/msa/rpau/RPAU-OB-2directions.html> or by calling (360) 664-6094), on January 22, 2008, at 10:00 a.m.

Date of Intended Adoption: Not earlier than January 23, 2008.

Submit Written Comments to: DSHS Rules Coordinator, P.O. Box 45850, Olympia, WA 98504-5850, delivery 4500 10th Avenue S.E., Lacey, WA 98503, e-mail DSHSRulesCoordinator@dshs.wa.gov, fax (360) 664-6185, by January 22, 2008.

Assistance for Persons with Disabilities: Contact Jenisha Johnson, DSHS Rules Consultant, by January 15, 2008, TTY (360) 664-6178 or (360) 664-6094 or by e-mail at johnsjl4@dshs.wa.gov.

Purpose of the Proposal and Its Anticipated Effects, Including Any Changes in Existing Rules: This rule making amends guidelines pertaining to the administration of sterile

procedures to more clearly articulate who can and cannot perform certain services.

Reasons Supporting Proposal: See above.

Statutory Authority for Adoption: RCW 74.08.090, 74.09.520.

Statute Being Implemented: RCW 74.08.090, 74.09.-520.

Rule is not necessitated by federal law, federal or state court decision.

Name of Proponent: Department of social and health services, governmental.

Name of Agency Personnel Responsible for Drafting, Implementation and Enforcement: Bev Lord, P.O. Box 45600, Olympia, WA 98504-5600, (360) 725-2536.

No small business economic impact statement has been prepared under chapter 19.85 RCW. The department has analyzed these rules and determined that no new costs will be imposed on small businesses or nonprofit organizations.

A cost-benefit analysis is not required under RCW 34.05.328. Rules are exempt per RCW 34.05.328 (5)(b)(vii), relating only to client medical or financial eligibility.

December 14, 2007
Stephanie E. Schiller
Rules Coordinator

AMENDATORY SECTION (Amending WSR 05-11-082, filed 5/17/05, effective 6/17/05)

WAC 388-106-0020 Under the MPC, COPES, MNRW, MNIW, and chore programs, what services are not covered? The following types of services are not covered under MPC, COPES, MNRW, MNIW, and chore:

(1) Child care.

(2) Individual providers ~~((and agency providers must not provide sterile procedures, administration of medications, or other tasks requiring a licensed health professional unless these tasks are provided through nursing delegation, self-directed care or provided by a family member))~~ must not provide:

(a) Sterile procedures unless the provider is a family member;

(b) Administration of medications or other tasks requiring a licensed health professional unless these tasks are provided through nurse delegation, self-directed care, or the provider is a family member.

(3) Agency providers, including family members who provide care as an agency provider, must not provide:

(a) Sterile procedures;

(b) Self-directed care;

(c) Administration of medications or other tasks requiring a licensed health care professional unless these tasks are provided through nurse delegation.

(4) Services provided over the telephone.

~~((4))~~ (5) Services to assist other household members not eligible for services.

~~((5))~~ (6) Development of social, behavioral, recreational, communication, or other types of community living skills.

~~((6))~~ (7) Nursing care.

~~((7))~~ (8) Pet care.

~~((8))~~ (9) Assistance with managing finances.

~~((9))~~ (10) Respite.

~~((10))~~ (11) Yard care.

WSR 08-01-090

PROPOSED RULES

DEPARTMENT OF

SOCIAL AND HEALTH SERVICES

(Health and Recovery Services Administration)

[Filed December 17, 2007, 11:32 a.m.]

Original Notice.

Preproposal statement of inquiry was filed as WSR 05-16-083.

Title of Rule and Other Identifying Information: The department is creating chapter 388-549 WAC, Rural health clinics.

Hearing Location(s): Office Building 2 - Auditorium (DSHS Headquarters), 1115 Washington, Olympia, WA 98504 (public parking at 11th and Jefferson. A map is available at <http://www1.dshs.wa.gov/msa/rpau/RPAU-OB-2directions.html> or by calling (360) 664-6094), on January 22, 2008, at 10:00 a.m.

Date of Intended Adoption: Not earlier than January 23, 2008.

Submit Written Comments to: DSHS Rules Coordinator, P.O. Box 45850, Olympia, WA 98504, delivery 4500 10th Avenue S.E., Lacey, WA 98503, e-mail DSHSRULES COORDINATOR@dshs.wa.gov, fax (360) 664-6185, by 5 p.m. on January 22, 2008.

Assistance for Persons with Disabilities: Contact Jenisha Johnson, DSHS Rules Consultant, by January 15, 2008, TTY (360) 664-6178 or (360) 664-6097 or by e-mail at johnsjl4@dshs.wa.gov.

Purpose of the Proposal and Its Anticipated Effects, Including Any Changes in Existing Rules: The department is creating the new chapter to implement a new payment methodology for rural health clinics (RHC) - replacing cost-based reimbursement methodology with Medicaid RHC prospective payment system (PPS).

Reasons Supporting Proposal: To be in compliance with the federal payment methodology for rural health clinics under Section 702 of the Benefit Improvement and Protection Act (BIPA) of 2000 which replaced cost-based reimbursement methodology with Medicaid RHC prospective payment system (PPS).

Statutory Authority for Adoption: RCW 74.08.090, 74.09.510, 74.09.522, 42 C.F.R. 405.2472, 42 C.F.R. 491.

Statute Being Implemented: RCW 74.08.090.

Rule is necessary because of federal law, 42 C.F.R. 405.2472, 42 C.F.R. 491, 42 U.S.C. 1396a(bb).

Name of Proponent: Department of social and health services, governmental.

Name of Agency Personnel Responsible for Drafting: Wendy Boedigheimer, P.O. Box 45504, Olympia, WA 98504-5504, (360) 725-1306; Implementation and Enforcement: Kevin Collins, P.O. Box 45510, Olympia, WA 98504-5510, (360) 725-2104.

No small business economic impact statement has been prepared under chapter 19.85 RCW. The department has analyzed the proposed rule amendments and concludes that they do not impose a disproportionate cost impact on small businesses. As a result, the preparation of a small business economic impact statement is not required.

A cost-benefit analysis is required under RCW 34.05.328. A preliminary cost-benefit analysis may be obtained by contacting Kevin Collins, P.O. Box 45510, Health and Recovery Service Administration, Olympia, WA 98504-5510, phone (360) 725-2104, fax (360) 586-9727, e-mail COLLIKM@dshs.wa.gov.

December 13, 2007
Stephanie E. Schiller
Rules Coordinator

Chapter 388-549 WAC

RURAL HEALTH CLINICS

NEW SECTION

WAC 388-549-1000 Rural health clinics—Purpose.

This chapter establishes the department's reimbursement methodology for rural health clinic (RHC) services. RHC conditions for certification are found in 42 CFR part 491.

NEW SECTION

WAC 388-549-1100 Rural health clinics—Definitions. This section contains definitions of words and phrases that apply to this chapter. Unless defined in this chapter or WAC 388-500-0005, the definitions found in the Webster's New World Dictionary apply.

"Base year" - The year that is used as the benchmark in measuring a clinic's total reasonable costs for establishing base encounter rates.

"Change in scope of service" - A change in the type, intensity, duration, or amount of service.

"Encounter" - A face-to-face visit between a client and a qualified rural health clinic (RHC) provider (e.g., a physician, physician's assistant, or advanced registered nurse practitioner) who exercises independent judgment when providing services that qualify for an encounter rate.

"Encounter rate" - A cost-based, facility-specific rate for covered RHC services, paid to a rural health clinic for each valid encounter it bills.

"Enhancements" (also called healthy options (HO) enhancement) - A monthly amount paid to RHCs for each client enrolled with a managed care organization (MCO). Plans may contract with RHCs to provide services under healthy options. RHCs receive enhancements from the department in addition to the negotiated payments they receive from the MCOs for services provided to enrollees.

"Fee-for-service" - A payment method the department uses to pay providers for covered medical services provided to medical assistance clients, except those services provided under the department's prepaid managed care organizations or those services that qualify for an encounter rate.

"Interim rate" - The rate established by the department to pay a rural health clinic for covered RHC services prior to the establishment of a prospective payment system (PPS) rate for that facility.

"Medicare cost report" - The cost report is a statement of costs and provider utilization that occurred during the time period covered by the cost report. RHCs must complete and submit a report annually to Medicare.

"Mobile unit" - The objects, equipment, and supplies necessary for provision of the services furnished directly by the RHC are housed in a mobile structure.

"Permanent unit" - The objects, equipment and supplies necessary for the provision of the services furnished directly by the clinic are housed in a permanent structure.

"Rural area" - An area that is not delineated as an urbanized area by the Bureau of the Census.

"Rural health clinic (RHC)" - A clinic, as defined in 42 CFR 405.2401(b), that is primarily engaged in providing RHC services and is:

- Located in a rural area designated as a shortage area as defined under 42 CFR 491.2;
- Certified by Medicare as a RHC in accordance with applicable federal requirements; and
- Not a rehabilitation agency or a facility primarily for the care and treatment of mental diseases.

"Rural health clinic (RHC) services" - Outpatient or ambulatory care of the nature typically provided in a physician's office or outpatient clinic and the like, including specified types of diagnostic examination, laboratory services, and emergency treatments. The specific list of services which must be made available by the clinic can be found under 42 CFR part 491.9.

NEW SECTION

WAC 388-549-1200 Rural health clinics—Enrollment. (1) To participate in the Title XIX (Medicaid) program and receive payment for services, a rural health clinic (RHC) must:

- (a) Receive RHC certification for participation in the Title XVIII (Medicare) program according to 42 CFR 491;
- (b) Sign a core provider agreement;
- (c) Comply with the clinical laboratory improvement amendments (CLIA) of 1988 testing for all laboratory sites per 42 CFR part 493; and
- (d) Operate in accordance with applicable federal, state, and local laws.

(2) An RHC may be a permanent or mobile unit. If an entity owns clinics in multiple locations, each individual site must be certified by the department in order to receive reimbursement from the department as an RHC.

(3) The department uses one of two timeliness standards for determining the effective date of a Medicaid-certified RHC.

(a) The department uses Medicare's effective date if the RHC returns a properly completed core provider agreement and RHC enrollment packet within sixty days from the date of Medicare's letter notifying the clinic of the Medicare certification.

(b) The department uses the date the signed core provider agreement is received if the RHC returns the properly completed core provider agreement and RHC enrollment packet after sixty days of the date of Medicare's letter notifying the clinic of the Medicare certification.

NEW SECTION

WAC 388-549-1300 Rural health clinics—Services.

(1) Rural health clinic (RHC) services are defined under 42 CFR 440.20(b).

(2) The department pays for RHC services when they are:

(a) Within the scope of an eligible client's medical assistance program. Refer to WAC 388-501-0060; and

(b) Medically necessary as defined in WAC 388-500-0005.

(3) RHC services may be provided by any of the following individuals in accordance with 42 CFR 405.2401:

- (a) Physicians;
- (b) Physician assistants (PA);
- (c) Nurse practitioners (NP);
- (d) Nurse midwives or other specialized nurse practitioners;
- (e) Certified nurse midwives;
- (f) Registered nurses or licensed practical nurses; and
- (g) Psychologists or clinical social workers.

NEW SECTION

WAC 388-549-1400 Rural health clinics—Reimbursement and limitations. (1) For rural health clinics (RHC) certified by Medicare on and after January 1, 2001, the department pays RHCs an encounter rate per client, per

$$\text{Base Encounter Rate} = \frac{(1999 \text{ Rate} \times 1999 \text{ Encounters}) + (2000 \text{ Rate} \times 2000 \text{ Encounters})}{(1999 \text{ Encounters} + 2000 \text{ Encounters})}$$

(c) Beginning in calendar year 2002 and any year thereafter, the encounter rate is increased by the MEI and adjusted for any increase or decrease in the clinic's scope of services.

(3) The department pays for one encounter, per client, per day except in the following circumstances:

(a) The visits occur with different doctors with different specialties; or

(b) There are separate visits with unrelated diagnoses.

(4) RHC services and supplies incidental to the provider's services are included in the encounter rate payment.

(5) Services other than RHC services that are provided in an RHC are not included in the RHC encounter rate. Payments for nonRHC services provided in an RHC are made on a fee-for-service basis using the department's published fee schedules. NonRHC services are subject to the coverage guidelines and limitations listed in chapters 388-500 through 557 WAC.

(6) For clients enrolled with a managed care organization, covered RHC services are paid for by that plan.

(7) The department does not pay the encounter rate or the enhancements for clients in state-only programs. Services provided to clients in state-only programs are considered fee-for-service, regardless of the type of service performed.

day using a prospective payment system (PPS) as required by 42 USC 1396a(bb) for RHC services.

(a) The department calculates the RHC's encounter rate for RHC core services as follows:

(i) Until the RHC's first audited Medicare cost report is available, the department pays an average encounter rate of other similar RHCs (such as hospital-based or free-standing) within the state, otherwise known as an interim rate.

(ii) Upon availability of the RHC's audited Medicare cost report, the department sets the clinic's encounter rate at one hundred percent of its costs as defined in the cost report. The RHC will receive this rate for the remainder of the calendar year during which the audited cost report became available. The encounter rate is then inflated each January 1 by the Medicare economic index (MEI) for primary services.

(2) For RHCs in existence during calendar years 1999 and 2000, the department sets the payment prospectively using a weighted average of one hundred percent of the clinic's total reasonable costs for calendar years 1999 and 2000 and adjusted for any increase or decrease in the scope of services furnished during the calendar year 2001 to establish a base encounter rate.

(a) The department adjusts a PPS base encounter rate to account for an increase or decrease in the scope of services provided during calendar year 2001 in accordance with WAC 388-549-1500.

(b) The PPS base encounter rates are determined using Medicare's audited cost reports and each year's rate is weighted by the total reported encounters. The department does not apply a capped amount to these base encounter rates. The formula used to calculate the base encounter rate is as follows:

NEW SECTION

WAC 388-549-1500 Rural health clinics—Change in scope of service. (1) The department considers a rural health clinic's (RHC) change in scope of service to be a change in the type, intensity, duration, and/or amount of services provided by the RHC. Changes in scope of service apply only to covered Medicaid services.

(2) When the department determines that a change in scope of service has occurred after the base year, the department will adjust the RHC's perspective payment system (PPS) rate to reflect the change.

(3) RHCs must:

(a) Notify the department's RHC program manager in writing, at the address published in the department's rural health clinic billing instructions, of any changes in scope of service no later than sixty days after the effective date of the change; and

(b) Provide the department with all relevant and requested documentation pertaining to the change in scope of service.

(4) The department adjusts the PPS rate to reflect the change in scope of service using one or more of the following:

(a) A Medicaid comprehensive desk review of the RHC's cost report;

(b) Review of a Medicare audit of the RHC's cost report; or
(c) Other documentation relevant to the change in scope of service.

(5) The adjusted encounter rate will be effective on the date the change of scope of service is effective.

WSR 08-01-096

WITHDRAWAL OF PROPOSED RULES

DEPARTMENT OF REVENUE

(By the Code Reviser's Office)

[Filed December 18, 2007, 9:21 a.m.]

WAC 458-20-258, proposed by the department of revenue in WSR 07-12-046 appearing in issue 07-12 of the State Register, which was distributed on June 20, 2007, is withdrawn by the code reviser's office under RCW 34.05.335(3), since the proposal was not adopted within the one hundred eighty day period allowed by the statute.

Kerry S. Radcliff, Editor
Washington State Register

WSR 08-01-109

PROPOSED RULES

DEPARTMENT OF LABOR AND INDUSTRIES

[Filed December 18, 2007, 1:41 p.m.]

Original Notice.

Preproposal statement of inquiry was filed as WSR 07-11-145.

Title of Rule and Other Identifying Information: Vocational rehabilitation—Vocational improvement project (pilot program), chapter 296-19A WAC, Vocational rehabilitation and chapter 296-15 WAC, Workers' compensation self-insurance rules and regulations.

WAC 296-19A-030 What are the responsibilities of the parties?

- The parties are identified.
- Language changed and reformatted to clarify the health care provider's responsibilities.
- Language changed/added to clarify the department's responsibilities for state fund and self-insured claims.
- Formatting changed to clarify the employer's responsibilities.
- Language changed/added to clarify worker's right and responsibilities.
- Language changed/added to clarify the vocational rehabilitation provider's responsibilities for state fund and self-insured claims and to remove duplication from other sections.

WAC 296-19A-040 What vocational rehabilitation services require authorization?

- Changed to clarify the types of referrals made for state fund claims.

WAC 296-19A-045 Which rules under "vocational rehabilitation referrals" apply only to state fund claims?

- Changed to list rules that apply to only state fund claims based on proposed rule amendments.

WAC 296-19A-065 What are assessment services?

- Changed to define assessment services for self-insured and state fund claims.
- Subsections were renumbered for clarity.

WAC 296-19A-070 What information must an assessment report include?

- Changed to identify and clarify what information must be included in assessment reports for both self-insured and state fund claims.
- Renumbered and wording changed for clarity.
- Changed to clarify the vocational rehabilitation provider must address whether the worker can return to work in any capacity with the employer of injury or if the worker is employable at a new job with transferable skills.

WAC 296-19A-080 How often must written progress reports be submitted during assessment activities provided for state fund claims?

- Changed to clarify this rule applies to state fund claims.
- Changed to clarify what information must be included in progress reports when assessment services are provided for state fund claims.

WAC 296-19A-090 What are vocational rehabilitation plan development services?

- The assigned vocational rehabilitation provider must meet with the worker in person and fully inform the worker of the return-to-work priorities in RCW 51.32.095(2) and of his or her rights and responsibilities under the workers' compensation vocational system.
- Included examples of worker's right and responsibilities.
- Changed and renumbered to clarify what information must be included in all assessment reports.

NEW SECTION

WAC 296-19A-092 When must plan development be completed?

- Vocational rehabilitation plans must be submitted within ninety calendar [days] of the date the worker is notified services were authorized.

NEW SECTION

WAC 296-19A-094 How can a provider request an extension of time to complete plan development?

- Vocational rehabilitation providers must submit a written request for an extension.
- Clarifies when and how requests for extension must be made.
- Clarifies information that must be included in the request for an extension.

NEW SECTION

WAC 296-19A-096 How will the department determine whether there is good cause to grant an extension of time?

- Provides examples of good cause.
- Clarifies action the department may take when there is not good cause for extending the ninety days.

NEW SECTION

WAC 296-19A-098 How often must written progress reports be submitted when plan development services are provided for state fund claims?

- Clarifies how often written progress reports must be submitted to the department for state fund claims.
- Identifies what information must be included in progress reports when plan development services are provided.

NEW SECTION

WAC 296-19A-100 What reports are required when vocational rehabilitation plan development services are completed?

- Deleted and moved language about progress reports to new section WAC 296-19A-098.
- Renumbered and changed wording for clarity.
- Changed to identify and clarify what information must be included in the closing report for both self-insured and state fund claims.
- Clarifies what must be included in the accountability agreement.

WAC 296-19A-110 What are vocational rehabilitation plan implementation and monitoring services?

- Renumbered and changed for clarity.
- Vocational services provider must contact the worker and the trainer or appropriate representative of the training program or school at least every fourteen days.
- Clarifies the vocational services provider's responsibility to assist the worker with job search before the completion of the plan.

NEW SECTION

WAC 296-19A-118 How often must written progress reports be submitted when plan implementation and monitoring services are provided for state fund claims?

- Clarifies how often written progress reports must be submitted to the department for state fund claims.

- Identifies what information must be included in progress reports when plan implementation and monitoring services are provided.

WAC 296-19A-120 What reports are required when vocational rehabilitation plan implementation and monitoring services are completed?

- Deleted and moved language about progress reports to new section WAC 296-19A-118.
- Renumbered and changed wording for clarity.
- Changed to identify and clarify what information must be included in the closing report for both self-insured and state fund claims.

Repealer: WAC 296-19A-480 When must providers comply with these rules?

NEW SECTION

WAC 296-15-4302 What is the self-insurance vocational reporting form?

- New form: The self-insurance vocational reporting form replaces the employability assessment report (EAR) and is used as a cover sheet for all vocational reports, including vocational plans, submitted to the department by the self-insured employer.

NEW SECTION

WAC 296-15-4304 What must the self-insurer do when an assessment report is received?

- A self-insurance vocational reporting form and the assessment report must be sent to the department within ten working days after the report is received by the self-insurer. Time-loss benefits must be reinstated if the department determines the assessment report failed to demonstrate the worker is able to work.
- Clarifies assessment report must meet the requirements in WAC 296-19A-070.
- New: The department makes the eligibility determination. See WAC 296-19A-030 (2)(b)(i).

NEW SECTION

WAC 296-15-4306 When must a self-insurer submit a vocational rehabilitation plan to the department?

- New process and reporting requirement: The plan must be submitted to the department within ninety calendar days after the date the department determined the worker was eligible for plan development services.
- Clarifies the self-insurer must submit the vocational provider's request for an extension if the plan is not completed within ninety days.
- New: The department makes the determination to approve or deny a plan. See WAC 296-19A-030 (2)(b)(iii) and (iv).

NEW SECTION

WAC 296-15-4308 What must the vocational rehabilitation plan include?

- New: Clarifies plans must meet the requirements in WAC 296-19A-100.

NEW SECTION

WAC 296-15-4310 What must the self-insurer do when the department denies the vocational rehabilitation plan?

- New: Clarifies what the self-insurer must do if the plan is denied or is returned as incomplete.

NEW SECTION

WAC 296-15-4312 What must the self-insurer do when the vocational rehabilitation plan is successfully completed?

- Reporting requirement: No change from WAC 296-15-430(5).
- A self-insurance vocational reporting form must be submitted within fifteen days of date time-loss ended.
- Clarifies the worker must be notified when time-loss benefits are terminated.
- New: Identifies what documents and information must be submitted with the self-insurance vocational reporting form.
- New: Clarifies that closing reports must meet the requirements in WAC 296-19A-120.

NEW SECTION

WAC 296-15-4314 What must the self-insurer do if the vocational rehabilitation plan is not successfully completed?

- Reporting requirement changed from ten calendar days in WAC 296-15-430(a): A self-insurance vocational reporting form and closing report must be submitted to the department within five working days.
- If the closing report recommends the worker is eligible for further services, the self-insurer must submit the report to the department within five working days of receiving the report.
- If the closing report recommends the worker is not eligible for further services, the report must be submitted to the department within five working days of the date time-loss ended.
- Identifies what documents and information must be submitted with the self-insurance vocational reporting form.
- New: Clarifies time-loss benefits must be continued when vocational closing report recommends the worker is eligible for further vocational services.
- New: Clarifies that closing reports must meet the requirements in WAC 296-19A-120.
- New: The department determines if the worker is eligible for further vocational rehabilitation services.

NEW SECTION

WAC 296-15-4316 What must the self-insurer do when the worker declines further vocational rehabilitation services and elects option 2 benefits?

- New reporting requirement: Required documentation must be submitted within five working days of

the date the self-insurer receives the worker's request for option 2 benefits.

- New: Provides actions that must be taken when the worker requests option 2 benefits.
- New: Identifies what documents and information must be submitted with the self-insurance vocational reporting form.
- Clarifies the self-insurer may pay the option 2 benefits before the department has issued an order.

NEW SECTION

WAC 296-15-4318 What must the self-insurer do when the worker elects option 2 benefits and the claim is closed?

- New reporting requirement: The total retraining costs paid to date for the worker after claim closure must be reported to the department until the benefits are no longer available to the worker or have been expended in total.

Repealer: WAC 296-15-430 Vocational services.

Hearing Location(s): Ramada Inn, 8909 Airport Road, Spokane, WA 99219, (509) 838-5211, on Tuesday, January 22, 2008, at 1:00 p.m. to 3:00 p.m.; and at the Department of Labor and Industries, Tukwila Office Training Room, 12806 Gateway Drive, Tukwila, WA 98168-3311, (206) 835-1000, on Thursday, January 24, 2008, at 11 p.m. [a.m.] to 1:00 p.m.

Date of Intended Adoption: February 29, 2008.

Submit Written Comments to: Valerie Grimm, P.O. Box 44208, Olympia, WA 98504-4208, e-mail colb235@lni.wa.gov, fax (360) 902-4960, by January 25, 2008.

Assistance for Persons with Disabilities: Contact Valerie Grimm by January 15, 2008, TTY (360) 902-5787 or (360) 902-5005.

Purpose of the Proposal and Its Anticipated Effects, Including Any Changes in Existing Rules: The proposed rules will assist in the implementation of chapter 72, Laws of 2007 (ESSB 5920) which increases benefits for eligible workers and accountability to improve vocational service outcomes and claim resolution. This rule making includes amendments of existing rules and new rules intended to assist in improving return-to-work outcomes for workers, reducing repeat referrals for vocational services, and increasing accountability and responsibility.

Reasons Supporting Proposal: The proposed rules will provide a consistent means for implementing the statutory change, thus reducing inconsistent interpretation and application of the law and potentially unnecessary litigation.

Statutory Authority for Adoption: RCW 51.04.020, 51.04.030, 51.32.095, 51.32.099 and 51.32.0991 (chapter 72, Laws of 2007, ESSB 5920).

Statute Being Implemented: RCW 51.32.095, 51.32.099 and 51.32.0991 (chapter 72, Laws of 2007, ESSB 5920).

Rule is not necessitated by federal law, federal or state court decision.

Name of Proponent: Department of labor and industries, governmental.

Name of Agency Personnel Responsible for Drafting: Cheri Ward, Tumwater, Washington, (360) 902-4581; Implementation: Sandra Dziedzic (State Fund)/Jean Vanek (Self-Insurance), Tumwater, Washington, (360) 902-4300/(360)

902-6907; and Enforcement: Robert Malooly, Tumwater, Washington, (360) 902-4209.

No small business economic impact statement has been prepared under chapter 19.85 RCW. This rule making is exempt under RCW 19.85.025(3), referring to RCW 34.05.-310(4), namely RCW 34.05.310 (4)(c), because it adopts and incorporates without material change ESSB 5920, chapter 72, Laws of 2007.

A cost-benefit analysis is not required under RCW 34.05.328. This rule making is exempt under RCW 34.05.-328 (5)(b)(iii) because it adopts and incorporates without material change ESSB 5920, chapter 72, Laws of 2007.

December 18, 2007

Judy Schurke

Director

NEW SECTION

WAC 296-15-4302 What is the self-insurance vocational reporting form? The Self-Insurance Vocational Reporting Form replaces the Employability Assessment Report (EAR) and is used as a cover sheet for all vocational reports submitted to the department by the self-insured employer.

Note: A Self-Insurance Vocational Reporting Form is not required if the worker is not eligible for vocational services because they returned or were released to work at the job at the time of injury or on the date of disease manifestation.

NEW SECTION

WAC 296-15-4304 What must the self-insurer do when an assessment report is received? (1) A self-insurer must submit a Self-Insurance Vocational Reporting Form and the assessment report to the department within ten working days after receiving the completed report. A completed report is one that, in the opinion of the department, meets the requirements in WAC 296-19A-070.

(2) When time-loss is terminated, based on the vocational rehabilitation provider's recommendations, the self-insurer must notify the worker or the worker's representative as required in WAC 296-15-420(9).

(3) The self-insurer can terminate time-loss on the date they receive the recommendation but, if the department determines the assessment report failed to demonstrate the worker is able to work, the self-insurer must request additional information from the vocational rehabilitation provider before resubmitting the report and an updated Vocational Services Reporting Form to the department.

(4) If the self-insurer terminated time-loss based on the assessment report's recommendation but the department concludes the assessment report failed to demonstrate the worker is able to work, the self-insurer must reinstate time-loss effective the day after the last date paid.

NEW SECTION

WAC 296-15-4306 When must a self-insurer submit a vocational rehabilitation plan to the department? No later than ninety calendar days after the date the department determined the worker was eligible for vocational plan devel-

opment services, the employer must submit a Self-Insurance Vocational Reporting Form and a completed vocational plan for the worker.

If the plan cannot be completed and submitted to the department within that time period, the self-insurer must, prior to the ninetieth day, submit a Self-Insurance Vocational Reporting Form and the vocational rehabilitation provider's request for an extension as required in WAC 296-19A-094.

NEW SECTION

WAC 296-15-4308 What must the vocational rehabilitation plan include? The vocational rehabilitation plan must meet the requirements in WAC 296-19A-100.

NEW SECTION

WAC 296-15-4310 What must the self-insurer do when the department denies the vocational rehabilitation plan? The vocational rehabilitation plan may be denied if the plan does not meet the requirements in WAC 296-19A-100 and the department cannot make a determination based on the information provided.

If the plan does not meet the requirements or is denied as incomplete, the self-insurer must correct the plan and/or obtain the information requested by the department, and resubmit the completed plan and an updated Vocational Services Reporting Form.

If the plan cannot be corrected and/or completed and submitted to the department within ninety calendar days after the date the department determined the worker was eligible for vocational plan development services, the self-insurer must, prior to the ninetieth day, submit a Self-Insurance Vocational Reporting Form and the vocational rehabilitation provider's request for an extension as required in WAC 296-19A-094.

NEW SECTION

WAC 296-15-4312 What must the self-insurer do when the vocational rehabilitation plan is successfully completed? The self-insurer must:

(1) Notify the worker or the worker's representative of the time-loss termination as required in WAC 296-15-420(9).

(2) Submit a Self-Insurance Vocational Reporting Form to the department within ten working days of the date time-loss benefits ended. The Self-Insurance Vocational Reporting Form must include:

(a) The total cost and time expended for the plan;

(b) The total time-loss compensation benefits paid during the plan; and

(c) The total vocational services costs paid since the date the worker was found eligible for services; and

(d) A closing report with a copy to the worker or the worker's representative. The closing report must meet the requirements in WAC 296-19A-120.

NEW SECTION

WAC 296-15-4314 What must the self-insurer do if the vocational rehabilitation plan is not successfully com-

pleted? When a vocational rehabilitation plan ends before successful completion, the vocational rehabilitation provider will submit a closing report to the self-insurer.

(1) **Plan not completed due to causes outside the worker's control.** Within ten working days of receiving the vocational closing report, the self-insurer must:

- (a) Continue time-loss benefits; and
- (b) Submit a Self-Insurance Vocational Reporting Form to the department. The form must include:
 - (i) The total cost and time expended for the plan;
 - (ii) The total time-loss compensation benefits paid during the plan;
 - (iii) The total vocational services costs paid since the date the worker was found eligible for services; and
 - (iv) A closing report with a copy to the worker or the worker's representative. The closing report must meet the requirements in WAC 296-19A-120(2).

(2) **Plan not completed due to worker's actions.** Within ten working days of receiving the vocational closing report, the self-insurer must:

- (a) Submit a request for suspension of benefits with supporting documentation.
- (b) Submit a Self-Insurance Vocational Reporting Form to the department. The form must include:
 - (i) The total cost and time expended for the plan;
 - (ii) The total time-loss compensation benefits paid during the plan;
 - (iii) The total vocational services costs paid since the date the worker was found eligible for services; and
 - (iv) A closing report with a copy to the worker or the worker's representative. The closing report must meet the requirements in WAC 296-19A-120(2).

(3) **Worker is employable.** When the worker is employable based on an assessment of the training completed to date, the self-insurer must:

- (a) Notify the worker or the worker's representative of the time-loss termination as required in WAC 296-15-420(9).
- (b) Submit a Self-Insurance Vocational Reporting Form to the department within five working days of the date time-loss benefits ended.
- (c) The Self-Insurance Vocational Reporting Form must include:
 - (i) The total cost and time expended for the plan;
 - (ii) The total time-loss compensation benefits paid during the plan;
 - (iii) The total vocational services costs paid since the date the worker was found eligible for services; and
 - (iv) A closing report with a copy to the worker or the worker's representative. The closing report must meet the requirements in WAC 296-19A-120(2).

NEW SECTION

WAC 296-15-4316 What must the self-insurer do when the worker declines further vocational rehabilitation services and elects option 2 benefits? When the department approves a rehabilitation plan, the worker will be notified in writing of their right to decline further vocational rehabilitation services and elect option 2 benefits within fifteen calendar days. When the worker elects option 2 benefits,

the self-insurer must take the following action within five working days of receiving the worker's request:

- (1) Terminate time-loss benefits with proper notification to the worker as required in WAC 296-15-420(9);
- (2) Establish the total amount of the option 2 award and a payment schedule for the option 2 benefits that begins the date time-loss is terminated;
- (3) Submit a Self-Insurance Vocational Reporting Form to the department. The Self-Insurance Vocational Reporting Form must include:
 - (a) The total vocational services costs paid since the date the worker was found eligible for services;
 - (b) The option 2 election form signed by the worker; and
 - (c) Documentation that includes the total amount of the option 2 award and payment schedule; and
 - (4) Commence payment of option 2 benefits to the worker according to the established payment schedule. The first payment must be made no later than fifteen days after the date time-loss is terminated. Option 2 benefits may be paid before the department issues an order.

NEW SECTION

WAC 296-15-4318 What must the self-insurer do when the worker elects option 2 benefits and the claim is closed? The self-insurer must submit a quarterly report to the department on the Self-Insurance Vocational Reporting Form listing the total retraining costs paid to date for the worker since the option 2 benefit was granted. These quarterly reports must be submitted until the worker has expended the total vocational costs available to him or her, or until five years have passed since the benefit was granted.

REPEALER

The following section of the Washington Administrative Code is repealed:

WAC 296-15-430 Vocational services.

AMENDATORY SECTION (Amending WSR 03-11-009, filed 5/12/03, effective 2/1/04)

WAC 296-19A-030 What are the responsibilities of the parties? ~~((All parties will))~~ The attending health care provider, department, self-insured employer, employer, worker and vocational rehabilitation provider have the following responsibilities in assisting the ((injured)) worker to become employable at gainful employment:

- (1) Attending health care provider. The attending ~~((physician shall))~~ health care provider must:
 - (a) Maintain open communication with the ((industrially injured or ill)) worker's assigned vocational rehabilitation ((counselor)) provider and the referral source. ((The attending physician shall))
 - (b) Respond to any request((s)) for information ((in a timely fashion and will)) which is necessary to evaluate a worker's:
 - (i) Ability to work;
 - (ii) Need for vocational services; and
 - (iii) Ability to participate in a vocational retraining plan.

(c) Do all that is possible to expedite the vocational rehabilitation process, including making an estimate of the ((worker's)) physical or mental capacities that affect the worker's employability. If unable to provide an estimate, refer the worker for the appropriate consultation or evaluation.

(2) ((The claims unit within the department shall notify the employer of the referral to a vocational rehabilitation provider.)) **Department.**

(a) **State fund claims.** For state fund claims, the department must:

(i) Obtain medical information required to initiate vocational rehabilitation services before a referral is made to a vocational rehabilitation provider.

(ii) Notify the chargeable employer(s), if any, at the time any referrals are made to a vocational rehabilitation provider.

(iii) Provide the vocational rehabilitation provider with access to all reports and any other relevant documentation generated during prior vocational rehabilitation services including plans that have been provided on any claim.

(iv) Review the assessment report and determine whether the worker is eligible for vocational rehabilitation plan development services.

(v) Notify all parties of the eligibility determination in writing. When the worker is eligible for plan development services, the notification letter must advise that the chargeable employer(s), if any, has fifteen calendar days from the date of the letter to make a valid return to work offer.

(vi) Assign plan development services to the vocational rehabilitation provider that completed the assessment report unless the department decides the provider cannot complete the required report.

(vii) Review the submitted vocational rehabilitation plan within fifteen days of receipt at the department, and determine whether to approve or deny the plan.

(viii) Notify all parties of plan approval or denial in writing. Should the department fail to send a notification letter within fifteen calendar days of the date the report is received by the department, the plan is considered approved.

When a plan is approved, the notification must advise the worker that he or she has fifteen calendar days from the date of the notification letter to decline vocational services and elect option 2 benefits as defined in RCW 51.32.099.

(b) **Self-insured claims.** For self-insured claims, the department must:

(i) Review the assessment report and determine whether the worker is eligible for vocational rehabilitation plan development services.

(ii) Notify all parties of the eligibility determination in writing.

When the worker is eligible for plan development services, the notification letter must advise the employer it has fifteen calendar days from the date of the letter to make a valid return to work offer; and

(iii) Review the submitted vocational rehabilitation plan within fifteen days of receipt at the department, and determine whether to approve or deny the plan.

(iv) Notify all parties of plan approval or denial in writing. Should the department fail to send a notification letter

within fifteen calendar days of the date the report is received by the department, the plan is considered approved.

When a plan is approved, the notification letter must advise the worker that he or she has fifteen calendar days from the date of the letter to elect option 2 benefits as defined in RCW 51.32.099.

(3) **Employer.** The employer ((shall)) must:

(a) Assist the vocational rehabilitation ((counselor)) provider in any way necessary to collect data regarding the ((former)) worker's gainful employment ((of the injured worker. Further, the employer will)) at the time of the injury.

(b) Assist the vocational rehabilitation ((counselor)) provider and attending ((physician)) health care provider to determine whether ((or not)) a ((modified)) job could be made available for employment of the ((injured)) worker.

(4) ((The injured worker shall cooperate with all reasonable requests from all responsible individuals in determining disability, developing and implementing the rehabilitation process. Should the injured worker fail to be cooperative, the sanctions as set out in RCW 51.32.110 shall be applied.))

Worker. The worker must fully participate in all aspects of their vocational services including determination of physical capacities, development of vocational goals, and implementation of the rehabilitation process. Examples include but are not limited to:

- Providing accurate and complete information regarding his or her work history and educational background.

- Attending all scheduled appointments.

- Cooperating with return to work efforts when it is determined return to work opportunities exist.

- Actively participating in selecting a job goal when it is determined retraining is necessary.

(5) **Vocational rehabilitation provider.** In assisting the ((injured)) worker to become employable at gainful employment, the vocational rehabilitation provider ((is to)) must:

(a) Follow the priorities ((as set out)) in RCW 51.32.095 and the requirements ((as set out)) in this chapter. ((This includes providing, upon request, copies of reports and attachments submitted to the referral source to the injured worker or their representative.))

(b) For state fund claims, immediately inform the department orally if the worker:

- (i) Returns to work;

- (ii) Is released for work without restrictions;

- (iii) Returns to work and is unsuccessful; or

- (iv) Fails to cooperate.

Note: Written notification and documentation must follow oral notification within two working days.

(c) Identify all vocational rehabilitation counselors and interns who provided services in each reporting period.

(d) Provide copies of reports and attachments submitted to the referral source to the employer (if different than the referral source) and the worker or the worker's representative when requested.

(e) Prior to a determination of eligibility, work with the employer, if necessary, to develop job analyses for work the employer is offering or has available and provide other assistance necessary to facilitate return to work with the employer.

(f) When providing plan development services, the vocational rehabilitation provider should, whenever possible and

appropriate, focus on identifying goals and occupations that are considered high demand in the workforce. High demand means the number of job openings in the labor market for the occupation or with the required skill set exceeds the supply of qualified workers.

(g) Should the employer choose to make a valid return to work offer within fifteen calendar days of the date of the notification letter, the vocational rehabilitation provider may provide assistance necessary to facilitate return to work with the employer.

AMENDATORY SECTION (Amending WSR 03-11-009, filed 5/12/03, effective 2/1/04)

WAC 296-19A-040 What vocational rehabilitation services require authorization? All vocational rehabilitation services must be preauthorized. For state fund claims, the department may make one or more of the following type of referrals: Early intervention; ability to work assessment ("AWA" or "assessment"); plan development; plan implementation; forensic services; or stand alone job analysis. Each referral is a separate authorization for vocational rehabilitation services.

AMENDATORY SECTION (Amending WSR 03-22-030, filed 10/28/03, effective 2/1/04)

WAC 296-19A-045 Which rules under "~~(department)~~ vocational rehabilitation referrals" apply only to ~~(the department)~~ state fund claims? WAC 296-19A-050, 296-19A-060, 296-19A-080, 296-19A-098, 296-19A-118, and 296-19A-125 through 296-19A-137 pertain only to referrals for vocational rehabilitation services made by the department for state fund claims.

AMENDATORY SECTION (Amending WSR 03-11-009, filed 5/12/03, effective 2/1/04)

WAC 296-19A-065 What are ~~(ability to work)~~ assessment ~~((AWA))~~ services? ((AWA)) Assessment services are used by the department or self-insured employer to determine if ~~(an industrially injured or ill)~~ a worker should receive vocational rehabilitation plan development services. ((AWA)) Assessment services may include, but are not limited to, the following:

- (1) ~~((Performing job analyses;~~
- (2) ~~Conducting labor market surveys;~~
- (3) ~~Assessing transferable skills;~~
- (4) ~~Obtaining work restrictions;~~
- (5) ~~Evaluating the injured worker's ability to work at the job of injury or any other job;~~
- (6) ~~Coordinating with medical providers to obtain physical capacities and restriction information and a release to participate in vocational rehabilitation plan development services;~~
- (7) ~~With authorization from the department, vocational testing may be used to evaluate the industrially injured or ill worker's ability to benefit from vocational rehabilitation services;)~~ Obtaining work restrictions;
- (2) ~~Performing job analyses;~~

(3) ~~Evaluating the worker's ability to work at the job of injury;~~

(4) ~~Assessing transferable skills;~~

(5) ~~Conducting labor market surveys as defined in WAC 296-19A-140;~~

(6) ~~Evaluating the worker's ability to work at any other job;~~

(7) ~~Evaluating the worker's ability to benefit from plan development services, including vocational testing if appropriate; and~~

(8) ~~Assessing the ((industrially injured or ill)) worker's need for preferred worker status and when appropriate educating the worker on the preferred worker benefit((, if appropriate)).~~

AMENDATORY SECTION (Amending WSR 03-11-009, filed 5/12/03, effective 2/1/04)

WAC 296-19A-070 What ~~((is an ability to work))~~ information must an assessment report include? (1) The ((AWA)) assessment report must include ~~((an))~~ information and evaluation of the ~~((industrially injured or ill))~~ worker's:

~~((a)) Age, education and experience;~~

~~(b) Transferable skills;~~

~~(c) Preexisting physical and mental conditions and the effect of those conditions on the worker's employability;~~

~~(d) Physical and mental conditions proximately caused by the worker's industrial injury or occupational disease and the effect of those conditions on the worker's employability;~~

~~(e) Wage at the time of injury;~~

~~(f) Work pattern;~~

~~(g) Significant barriers to employment;~~

~~(h) Labor market;~~

~~(i) Complete work history, addressing any gaps in employment, in addition to information about education level, courses or transcripts, licenses, certifications or registrations that the worker may have obtained in the past; and~~

~~(j) The report must address the first four return to work priorities set forth in RCW 51.32.095(2).~~

~~(2)) (a) Age;~~

~~(b) Education, including information about education level, courses or transcripts, licenses, and certifications or registrations that the worker may have obtained in the past;~~

~~(c) Entire work history, addressing any gaps in employment;~~

~~(d) Transferable skills and experience, whether obtained from prior employment, prior courses and training, prior vocational rehabilitation services or plans, or nonwork related activities such as hobbies and/or volunteer experience;~~

~~(e) Physical and mental conditions proximately caused by the worker's injury or occupational disease, and the effect of those conditions on the worker's ability to work and/or benefit from vocational services;~~

~~(f) Preexisting physical and mental conditions and the effect of those conditions on the worker's ability to work and/or benefit from vocational services;~~

~~(g) Postinjury physical and mental conditions and the effect of those nonrelated conditions on the worker's ability to work and/or benefit from vocational services;~~

(h) Wage and employment pattern at the time of injury;

(i) Barriers to employment, including whether the barriers can be removed and/or what is needed to address the barriers; and

(j) Labor market information as defined in WAC 296-19A-140.

(2) If the vocational rehabilitation provider cannot obtain one or more of the above categories of information, the provider must document in the report all efforts made to obtain the information and why the information could not be obtained.

(3) The report must address whether the worker can return to work in any capacity with the employer of injury or if the worker is employable at a new job with transferable skills.

(4) The ((AWA)) assessment report must also include one of the following recommendations:

(a) Able to work: The ((injured)) worker is employable at gainful employment. The report must include:

(i) Whether the worker is employable with the employer of injury or current employer, or if not, a list of job possibilities for which the worker is qualified;

(ii) A medically approved job analysis. When this is not obtainable, medically approved physical capacities information regarding the worker's ability to perform the job may be used; and

(iii) Labor market information as defined in WAC 296-19A-140 supporting the vocational rehabilitation provider's recommendation. Labor market information is not necessary when the ((injured)) worker is medically released to work for their job of injury at their previous work pattern;

(b) Further services appropriate: Vocational rehabilitation services are necessary and likely to enable the ((injured)) worker to become employable at gainful employment. The report must include:

(i) ((An analysis demonstrating how vocational rehabilitation plan development services are necessary and likely to enable the injured worker to become employable at gainful employment;

(ii) The specific return to work possibilities investigated and the reasons why they were ruled out including labor market information when necessary; or)) The specific return to work possibilities investigated and the reasons why they were ruled out which may include labor market information as defined in WAC 296-19A-140;

(ii) An analysis explaining how vocational rehabilitation plan development services are likely to enable the worker to become employable at gainful employment. The analysis may include but is not limited to:

(A) Vocational evaluation that addresses the worker's ability to benefit from vocational rehabilitation services;

(B) Information regarding the worker's medical and/or psychological condition(s);

(C) Labor market information as defined in WAC 296-19A-140;

(D) A discussion of the worker's participation in vocational activities to date; and

(E) Any other relevant information.

(c) Further services not appropriate: The ((injured)) worker is not likely to benefit from vocational services. The report must include:

(i) An analysis explaining why vocational rehabilitation services are not appropriate;

(ii) ((Identifying)) Barriers identified that will make it unlikely the worker will benefit from vocational rehabilitation services, consistent with the requirements in WAC 296-19A-010(1);

(iii) Medical, ((labor market, and/or)) psychological or other vocationally relevant information((, as necessary, supporting the));

(iv) Labor market information as defined in WAC 296-19A-140; and

(v) Other information, as necessary, supporting the vocational rehabilitation provider's recommendations.

(d) Return to work: The ((injured)) worker has returned to work. The report must specify and/or document attempts to obtain the following information:

(i) A description of the job the worker returned to;

(ii) The name of the employer;

(iii) The date that the worker returned to work; and

(iv) The worker's monthly wages.

~~(((3) The provider must immediately inform the department orally if the worker has returned to work or if the provider has documentation that the worker is medically released without restrictions or has returned to work. The provider must follow the oral notification with written notification within two working days. The provider must attach documentation showing the worker was medically released to work without restrictions. Except for completing the closing report, the provider should not perform any other work on the AWA without the prior authorization of the referral source.))~~

(5) When the worker has returned to work to the job of injury or is medically released without restrictions, the vocational rehabilitation provider should complete the closing report. No other work should be performed without the prior authorization of the referral source.

AMENDATORY SECTION (Amending WSR 03-22-030, filed 10/28/03, effective 2/1/04)

WAC 296-19A-080 How often must written progress reports be ((completed and)) submitted during assessment activities provided for state fund claims? (1) The vocational rehabilitation provider must submit a written progress report to the department, and upon request, to the ((injured)) employer, worker or ((the injured worker's)) his or her representative, every thirty calendar days from the date of the electronic referral ((summarizing progress during the most recent reporting period)).

(2) The written progress report must summarize progress during the most recent reporting period and include:

(((+)) (a) A detailed explanation why the ((AWA)) assessment report was not completed as of the date of the report;

(((+)) (b) A summary of all activities taken in the past thirty days, including progress on previously recommended actions;

~~((3))~~ (c) Identification and analysis of any barriers preventing completion of the referral; and

~~((4))~~ (d) A description of the specific actions the provider intends to take to overcome barriers and the expected time frame to complete those actions.

AMENDATORY SECTION (Amending WSR 03-11-009, filed 5/12/03, effective 2/1/04)

WAC 296-19A-090 What are vocational rehabilitation plan development services? Vocational rehabilitation plan development services are authorized to obtain the vocational rehabilitation provider's assistance in producing a vocational rehabilitation plan for ~~((an industrially injured or ill))~~ a worker. The vocational rehabilitation provider will work with the ~~((industrially injured or ill))~~ worker in the development of the plan. Covered services include, but are not limited to ~~((, the following))~~:

~~(1) ((Vocational counseling and occupational exploration;~~

~~(2) Identifying job goal, training needs, resources, and expenses;~~

~~(3) Vocational rehabilitation plan development services are authorized for the vocational rehabilitation provider to produce a recommended vocational rehabilitation plan for an industrially injured or ill worker;~~

~~(4) Coordinating with medical providers to obtain physical capacities and restrictions information and a release to participate in a vocational rehabilitation plan;~~

~~(5) Vocational testing; and~~

~~(6) Identify, evaluate, and plan education and training resources, when necessary.)~~ An initial meeting between the assigned vocational rehabilitation provider and the worker.

The assigned vocational rehabilitation provider must meet with the worker in person and fully inform the worker of the return to work priorities set forth in RCW 51.32.095(2) and of his or her rights and responsibilities under the workers' compensation vocational system. The vocational rehabilitation provider must use tools provided by the department in order to document this requirement.

Exception: For out-of-state referrals, the counselor providing direct services to the worker may be considered the assigned vocational rehabilitation provider for purposes of this meeting.

The rights and responsibilities include but are not limited to:

(a) The responsibility of the worker and vocational services provider to cooperate with the plan development process and to submit a plan within ninety calendar days;

(b) An explanation of the benefits available to the worker, including the right to choose to participate in retraining or elect option 2 benefits after a plan has been approved; and

(c) An explanation of the possible action the department or self-insured employer may take under RCW 51.32.110 and WAC 196-14-410 should the worker be determined to be noncooperative during the plan development process.

(2) Vocational counseling and occupational exploration;

(3) Identifying a potential job goal and estimating the training needs, resources, and expenses necessary to complete that goal;

(4) Vocational testing; and

(5) Coordinating with medical providers to obtain approval of job analyses and a release to participate in a vocational rehabilitation plan.

NEW SECTION

WAC 296-19A-092 When must plan development be completed? The vocational rehabilitation provider must submit the completed plan within ninety calendar days of the date the worker was notified by letter that plan development services were authorized. The ninety-day requirement may be extended only for good cause. The vocational rehabilitation provider must continue working on plan development while the department evaluates the extension request.

NEW SECTION

WAC 296-19A-094 How can a provider request an extension of time to complete plan development? (1) When the plan cannot be completed and submitted to the department within ninety calendar days (see WAC 296-19A-094), the vocational rehabilitation provider seeking an extension must submit a written request to the department for state fund claims or the self-insured employer. The vocational rehabilitation provider must continue working on plan development while the department evaluates the extension request.

(2) The written request for an extension must:

(a) Explain why there is good cause for an extension, with supporting documentation;

(b) Specify the number of additional calendar days requested to complete plan development; and

(c) Identify any anticipated barriers to the completion of plan development.

NEW SECTION

WAC 296-19A-096 How will the department determine whether there is good cause to grant an extension of time? (1) The department will determine whether good cause exists on a case-by-case basis.

(2) The department will grant an extension of time for good cause when there is a significant delay in the plan development process and the cause is beyond the worker's or vocational rehabilitation provider's control.

Examples of causes that are beyond the worker's or provider's control include, but are not limited to:

- A death in the worker's immediate family. For purposes of this section, immediate family is defined as spouse, domestic partner, child, sibling, parent or grandparent.

- Delays caused by documented changes in the worker's medical ability to participate in plan development.

- Information received by the vocational rehabilitation provider that impacts plan development and was not available when assessment services were provided.

- Documented delay in receipt of requested information from a medical provider relevant to developing the vocational plan.

- The impact of previously identified barriers to employment and/or retraining.

(3) Noncooperation by a worker, under RCW 51.32.110 and WAC 196-14-410, is not good cause for granting an extension of time.

(4) If the department finds there is not good cause for the delay in submitting a vocational plan, the department may take action, including but not limited to:

(a) Suspension of further vocational services if the worker has been found noncooperative under RCW 51.32.110 and WAC 196-14-410, until such noncooperative actions cease or have been cured.

(b) Assignment of a new vocational provider.

(c) Allowing the vocational rehabilitation provider to complete the referral with monitoring of further plan development services by the department or self-insured employer.

NEW SECTION

WAC 296-19A-098 How often must written progress reports be submitted when plan development services are provided for state fund claims? (1) The vocational rehabilitation provider must submit a written progress report to the department every thirty calendar days from the date of the electronic referral.

(2) The first progress report must document the assigned vocational rehabilitation provider met with the worker in person and fully informed the worker of the return to work priorities in RCW 51.32.095(2) and his or her rights and responsibilities.

(3) All progress reports must summarize progress during the most recent reporting period and include the following:

(a) Description of the return to work goals explored, accepted or ruled out, including any jobs offered by the employer;

(b) Review of the return to work priorities being addressed;

(c) Summary of all actions taken, including progress on previously recommended actions;

(d) Description of the worker's participation in vocational activities and compliance with the responsibilities in WAC 296-19A-030(4).

(e) Identification and analysis of any barriers preventing completion of the referral; and

(f) Description of the specific actions the vocational rehabilitation provider intends to take to overcome barriers and the expected time frame to complete those actions.

AMENDATORY SECTION (Amending WSR 03-11-009, filed 5/12/03, effective 2/1/04)

WAC 296-19A-100 What reports ~~((does the department require))~~ are required when vocational rehabilitation plan development services are ~~((provided at its request))~~ completed? ~~((1))~~ Progress reports. The vocational rehabilitation provider must submit a written progress report to the department, and upon request, to the injured worker or the injured worker's representative, every thirty calendar days from the date of the electronic referral summarizing progress during the most recent reporting period. The progress report must include the following:

~~(a) Description of the return to work goals explored, accepted or ruled out;~~

~~(b) Review of the return to work priorities being addressed;~~

~~(c) Summary of all actions taken, including progress on previously recommended actions;~~

~~(d) Identification and analysis of any barriers preventing completion of the referral; and~~

~~(e) Description of the specific actions the provider intends to take to overcome barriers and the expected time frame to complete those actions.~~

(2)) When plan development services are completed, the vocational rehabilitation provider must submit one of the following reports:

(1) Vocational rehabilitation plan. The vocational rehabilitation provider must address the return to work priorities listed in RCW 51.32.095(2) in the plan and explain why each preceding priority would not help the ~~((industrially injured or ill))~~ worker return to work. The vocational plan must also include the following information:

(a) An assessment of the ~~((industrially injured or ill))~~ worker's skills and abilities considering the ~~((industrially injured or ill))~~ worker's:

(i) Physical capacities and mental status((:));

(ii) Aptitudes ((and));

(iii) Transferable skills gained through prior work experience, education, training ((and avocation)), hobbies, volunteer experience or other nonwork related activities;

~~(b) ((The services necessary to enable the industrially injured or ill worker to become employable in the labor market;~~

~~(c) Labor market survey supportive of the industrially injured or ill worker's employability upon plan completion;~~

~~(d) Documentation of the time and costs required for completion of the plan;~~

~~(e) A direct comparison of the industrially injured or ill worker's skills, both existing and those to be acquired through the plan, with potential types of employment to demonstrate a likelihood of plan success;)) Proposed occupational goal;~~

(c) The services necessary to enable the worker to become employable in the labor market;

(d) Labor market survey as defined in WAC 296-19A-140, supportive of the worker's employability upon plan completion;

(e) Documentation of the time and costs required for completion of the plan;

(f) A medically approved job analysis for the proposed retraining job goal;

(g) ~~((Any other information that may significantly affect the plan; and~~

~~(h) An agreement signed by the provider and industrially injured or ill worker that:~~

~~(i) Acknowledges that the provider and the industrially injured or ill worker have reviewed, understand and agree to the vocational rehabilitation plan; and~~

~~(ii) Sets forth the provider's and industrially injured or ill worker's responsibilities for the successful implementation and completion of the vocational rehabilitation plan.)) A list of the skills the worker will acquire through retraining;~~

(h) A description of the services that will be provided prior to completion of the plan that will assist the worker to successfully transition to gainful employment;

(i) Any other information that may significantly affect the plan; and

(j) An accountability agreement signed by the vocational rehabilitation provider and worker that:

(i) Acknowledges that the vocational rehabilitation provider and the worker have reviewed, understand and agree to the vocational rehabilitation plan;

(ii) Sets forth the vocational rehabilitation provider's and worker's responsibilities for the successful implementation and completion of the vocational rehabilitation plan;

(iii) Details expectations regarding progress, attendance, and other factors influencing completion of the plan; and

(iv) Acknowledges the worker understands that failure to comply with the agreed expectation will result in initiation of the process to suspend benefits in accordance with RCW 51.32.110 and WAC 296-14-410.

The vocational rehabilitation provider must use a statement approved by, or substantially similar to a statement used by, the department in order to document this agreement.

~~((3))~~ (2) Closing report. If the vocational rehabilitation provider has to stop plan development before a rehabilitation plan is ~~((submitted and/or))~~ approved, the vocational rehabilitation provider must submit a plan development closing report. The report must include:

(a) A list of the reasons the vocational rehabilitation provider cannot proceed with vocational rehabilitation plan development activities;

(b) Supporting documentation, such as: ~~((Goals))~~ The goals that were researched, the job analyses that were developed, and/or labor market research as defined by WAC 296-19A-140 that was conducted; and

(c) ~~((Address))~~ An assessment addressing whether ~~((or not))~~ further vocational rehabilitation services may be necessary and likely to enable the ~~((injured))~~ worker to become employable.

AMENDATORY SECTION (Amending WSR 03-11-009, filed 5/12/03, effective 2/1/04)

WAC 296-19A-110 What are vocational rehabilitation plan implementation and monitoring services? Vocational rehabilitation plan implementation and monitoring services are those services a vocational rehabilitation provider provides to assist ~~((an industrially injured or ill))~~ a worker to successfully complete a vocational rehabilitation plan. These services may include, but are not limited to, the following:

~~(1) ((Maintain sufficient contact with the industrially injured or ill worker, trainer and medical providers to make sure the worker successfully enters and progresses in the vocational rehabilitation plan;~~

~~(2))~~ Contacting the worker and trainer or appropriate representative of the training program or school, at least every fourteen calendar days to:

(a) Confirm ~~((that))~~ the ~~((industrially injured or ill))~~ worker has received all necessary equipment and supplies;

~~((3)) Contact the industrially injured or ill worker and trainer at least every thirty days to identify potential problems;~~

~~(4) Notify the department if the plan needs to be interrupted;~~

~~(5) Notify)~~ (b) Make sure the worker successfully enters and progresses in the vocational rehabilitation plan;

(c) Identify potential problems;

(d) Monitor the worker's progress; and

(e) Resolve any problems that might arise, or submit documentation regarding why it cannot be resolved;

(2) Notifying the department or self-insured employer when the ~~((industrially injured or ill))~~ worker completes the plan;

~~((6) Monitor the industrially injured or ill worker's progress and resolve any problems that might arise or address by submitting supporting documentation regarding why it cannot be brought to resolution;~~

~~(7))~~ (3) Assisting ~~((in))~~ with job search assistance ~~((prior to))~~ before the completion of the vocational rehabilitation plan((-

~~(8) Document the industrially injured or ill)) and may include referral to community based organizations offering free resources for job search assistance such as resume writing and job seeking skills;~~

(4) Documenting the worker's acquisition of skills; ~~((and~~

~~(9) Notify))~~ (5) Notifying the department if the plan needs to be terminated((-

~~(10) Obtain))~~; and

(6) Obtaining preferred worker status for worker, if appropriate.

NEW SECTION

WAC 296-19A-118 How often must written progress reports be submitted when plan implementation and monitoring services are provided for state fund claims?

(1) The vocational rehabilitation provider must submit a written progress report to the department every thirty calendar days from the date of the electronic referral.

(2) All progress reports must summarize progress during the most recent reporting period and must include the following:

(a) A review of the worker's compliance with the accountability agreement and vocational rehabilitation plan, including any issues involving attendance, grades and progression;

(b) A list of the dates the vocational rehabilitation provider contacted the worker and training site;

(c) A description of the work-related skills the worker has acquired so far and a comparison with the vocational rehabilitation plan;

(d) A summary of all actions taken in the past thirty days, including progress on previously recommended actions;

(e) Identification and analysis of any barriers preventing completion of the plan and actions taken by the vocational rehabilitation provider to address those barriers; and

(f) A statement of whether the worker is progressing as expected and will complete the plan by the target end date.

AMENDATORY SECTION (Amending WSR 03-22-030, filed 10/28/03, effective 2/1/04)

WAC 296-19A-120 What reports (~~does the department require~~) are required when vocational rehabilitation plan implementation and monitoring services are (~~provided at its request~~) completed? (~~(1) Progress reports. The vocational rehabilitation provider must submit a written progress report to the department, and upon request, to the injured worker or the injured worker's representative, every thirty calendar days from the date of the electronic referral summarizing progress during the most recent reporting period. The progress report must include the following:~~

- ~~(a) Review of the industrially injured or ill worker's compliance with the vocational rehabilitation plan;~~
- ~~(b) A list of the dates the provider contacted the industrially injured or ill worker and training site;~~
- ~~(c) Description of the skills the worker has acquired so far and a comparison with the vocational rehabilitation plan;~~
- ~~(d) Summary of all actions taken in the past thirty days, including progress on previously recommended actions;~~
- ~~(e) Identification and analysis of any barriers preventing completion of the referral;~~
- ~~(f) Statement of whether the industrially injured or ill worker will complete the plan by the target plan end date.~~

~~(2) Closing report.)~~ When plan implementation and monitoring services are completed, the vocational rehabilitation provider must submit a closing report with one of the following recommendations:

(1) Plan successfully completed. If the (~~industrially injured or ill~~) worker successfully completes the vocational rehabilitation plan, the closing report, at a minimum, must contain the following information:

- ~~(a) An assessment of the (~~industrially injured or ill~~) worker's employability status at the time of closure;~~
- ~~(b) (~~An assessment of the skills acquired by the industrially injured or ill worker as compared to the vocational rehabilitation plan;~~) A list of courses the worker completed and an assessment of the work-related skills acquired by the worker during the training plan;~~

~~(c) (~~A statement as to~~) Whether (~~or not the industrially injured or ill~~) the worker has returned to gainful employment. If so, list the job title, employer, return to work date, and monthly salary; (~~and~~)~~

~~(d) A description of the barriers, if any, to the (~~industrially injured or ill~~) worker's ability to return to gainful employment; and~~

~~(e) A description of the job search assistance provided.~~

~~(~~(3)~~)~~ (2) Plan not completed. If the (~~industrially injured or ill~~) worker does not successfully complete the vocational rehabilitation plan, the closing report, at a minimum, must contain the following information:

~~(a) (~~Explain~~) An explanation of why the vocational rehabilitation plan cannot be modified or completed;~~

~~(b) (~~Assess the industrially injured or ill~~) An assessment of the worker's employability status at the time the plan stopped;~~

~~(c) (~~Assess what skills the industrially injured or ill worker acquired and compare them to the vocational rehabilitation plan;~~) A list of the courses completed and an assess-~~

ment of the work-related skills the worker acquired during the training plan;

~~(d) (~~Indicate~~) Whether (~~or not the industrially injured or ill~~) the worker has returned to work. If so, list the job title, employer, return to work date, and monthly salary; and~~

~~(e) (~~Describe~~) A description of any remaining barriers that may keep the (~~industrially injured or ill~~) worker from returning to work.~~

REPEALER

The following section of the Washington Administrative Code is repealed:

WAC 296-19A-480 When must providers comply with these rules?

WSR 08-01-113

PROPOSED RULES

DEPARTMENT OF TRANSPORTATION

[Filed December 18, 2007, 2:09 p.m.]

Original Notice.

Preproposal statement of inquiry was filed as WSR 07-16-057.

Title of Rule and Other Identifying Information: Establishment of toll rates for SR 167 HOT lanes pilot project.

Hearing Location(s): Transportation Building, 310 Maple Park Drive, Olympia, WA 98504, on February 19, 2008, at 9:00 a.m.

Date of Intended Adoption: February 19, 2008.

Submit Written Comments to: Reema Griffith, P.O. Box 47308, Olympia, WA 98504, e-mail griffir@wstc.wa.gov, fax (360) 705-6802, by February 19, 2008.

Assistance for Persons with Disabilities: Contact Reema Griffith by February 19, 2008, TTY (800) 833-6388, ask to be connected to (360) 705-7070.

Purpose of the Proposal and Its Anticipated Effects, Including Any Changes in Existing Rules: Pursuant to RCW 47.56.403 (SR 167 HOT lanes) this rule establishes toll rates for the SR 167 HOT lanes pilot project.

Reasons Supporting Proposal: The commission's proposed toll rates establish charges for vehicles using the SR 167 HOT lanes pilot project.

Statutory Authority for Adoption: RCW 47.56.403.

Rule is not necessitated by federal law, federal or state court decision.

Name of Proponent: Washington state transportation commission, governmental.

Name of Agency Personnel Responsible for Drafting and Enforcement: Reema Griffith, P.O. Box 47308, Olympia, WA 98504, (360) 705-7070; and Implementation: Greg Selstead, 310 Maple Park Drive, Olympia, WA 98504, (360) 705-7801.

No small business economic impact statement has been prepared under chapter 19.85 RCW. The proposed rules do not apply to "businesses in an industry," as described in RCW 19.85.030 (1)(a), but rather the rules apply to all vehicles using the SR 167 HOT lanes pilot project.

A cost-benefit analysis is not required under RCW 34.05.328. The Washington state transportation commission is not a listed agency under RCW 34.05.328 (5)(a)(i).

December 18, 2007
Reema Griffith
Executive Director

AMENDATORY SECTION (Amending WSR 07-13-010, filed 6/8/07, effective 7/9/07)

WAC 468-270-070 What will the toll rates be for the Tacoma Narrows Bridge?

Rate table \$3.00 cash/\$1.75 "Good to Go!™"
(two axle vehicles)

Tacoma Narrows Bridge			
	Cash toll rate	"Good To Go!™" toll rates	
2 axle	\$3.00	\$1.75	
3 axle	\$4.50	\$2.65	(3)
4 axle	\$6.00	\$3.50	
5 axle	\$7.50	\$4.40	(3)
6 or more axles	\$9.00	\$5.25	

((SR 167 HOT lanes To be determined))	
--	--

Notes:

- (1) The base toll rate is the toll rate per axle. It is only used to calculate multi-axle rates, which are calculated as a multiplier of the base toll rate (\$1.50 for cash and \$0.875 for "Good to Go!™" toll rates).
- (2) The "Good To Go!™" toll rates are in effect through June 30, 2008, or until changed by the commission. If no further action is taken by the commission, on July 1, 2008, the cash toll rate column becomes the toll rate for all vehicles.
- (3) Rate rounded up to nearest five cents.

NEW SECTION

WAC 468-270-075 What will the toll rates be for the SR 167 HOT lanes pilot project? A variable toll rate schedule will be applied by WSDOT. Toll rates will vary based upon several factors including time of day, traffic volumes, traffic demand, and overall corridor performance. The toll rate schedule shall be adjusted as needed by WSDOT to meet HOV performance criteria as defined in RCW 47.56.403 and WAC 468-300-828 in order to maintain average HOT lane vehicle speeds above forty-five miles per hour, at least ninety percent of the time during peak hours.

When the SR 167 HOT lanes are in operation, the minimum toll rate is \$0.50 and the maximum toll rate is \$9.00.

AMENDATORY SECTION (Amending WSR 07-13-010, filed 6/8/07, effective 7/9/07)

WAC 468-270-100 What vehicles are exempt from paying tolls on the SR 167 HOT lanes? ~~((RCW 47.56.403 establishes an exempt category of vehicles. The transportation commission may include other exempt vehicles before~~

~~tolling commences.))~~ Vehicles described in RCW 47.56.403 and WAC 468-510-010 are exempt from paying tolls, including transit buses and vanpool vehicles owned or operated by any public agency. All other vehicles using the SR 167 HOT lanes must pay the required toll. All toll-paying vehicles must have a transponder and a valid "Good To Go!™" account.

WSR 08-01-118

PROPOSED RULES

SUPERINTENDENT OF PUBLIC INSTRUCTION

[Filed December 18, 2007, 2:56 p.m.]

Original Notice.

Preproposal statement of inquiry was filed as WSR 07-18-072.

Title of Rule and Other Identifying Information: Collection of evidence rules (WASL): WAC 392-501-300 General description, 392-501-310 Eligibility, 392-501-320 Application process, 392-501-330 Guidelines and protocols, 392-501-340 Sufficiency process for all content areas, 392-501-350 Scoring process for all content areas, 392-501-360 Standard setting process for all content areas, 392-501-370 Reporting process for all content areas for the collection of evidence, and 392-501-380 Collection of evidence adherence to national standards.

Hearing Location(s): OSPI, Old Capitol Building, 600 Washington Street, Olympia, WA 98504, on January 25, 2008, at 10:00 a.m.

Date of Intended Adoption: January 29, 2008.

Submit Written Comments to: Leslie Klenk, P.O. Box 47200, Olympia, WA 98504-7200, e-mail Lesley.klenk@k12.wa.us, fax (360) 725-6332, by January 24, 2008.

Assistance for Persons with Disabilities: Contact Penny Coker by January 24, 2008, TTY (360) 664-3631 or (360) 725-6142.

Purpose of the Proposal and Its Anticipated Effects, Including Any Changes in Existing Rules: The purpose of the proposed rules is to comply with the legislative directive to implement an alternative assessment method that shall be an evaluation of a collection of work samples prepared and submitted by an applicant, as provided for in RCW 28A.655-065, to demonstrate achievement of the state content areas in which the student has not yet met standard on the high school Washington assessment of student learning (WASL).

Reasons Supporting Proposal: The proposed rules provide the guidelines, protocols and scoring criteria for submission and evaluation of a collection of work samples, otherwise referred to as a collection of evidence, as an alternative assessment method for the WASL.

Statutory Authority for Adoption: RCW 28A.655.061, 28A.665.065.

Statute Being Implemented: RCW 28A.655.061, 28A.655.065 [28A.655.065].

Rule is not necessitated by federal law, federal or state court decision.

Name of Proponent: [Superintendent of public instruction], governmental.

Name of Agency Personnel Responsible for Drafting, Implementation and Enforcement: Lesley Klenk, OSPI, (360) 725-6330.

No small business economic impact statement has been prepared under chapter 19.85 RCW.

A cost-benefit analysis is not required under RCW 34.05.328.

December 18, 2007
Dr. Terry Bergeson
Superintendent of
Public Instruction

NEW SECTION

WAC 392-501-300 General description. A collection of evidence (COE) is a high school graduation alternative assessment option authorized under RCW 28A.655.065 that evaluates a set of work samples in a specific content area (mathematics, reading, and/or writing) based on classroom work prepared by a student. Students may prepare a COE for one or more content areas.

NEW SECTION

WAC 392-501-310 Eligibility. A student who has taken the Washington assessment of student learning (WASL) at least once and has not met standard in one or more of the content areas is eligible to submit a collection for each content area in which they have not met standard as an alternative assessment to the WASL if:

(1) The student has sat for and generated a valid scale score during the administration of the WASL.

(2) The student has met any applicable attendance and remediation or supplemental instruction requirements contained in the student's student learning plan developed under RCW 28A.655.061, unless such attendance and/or remediation criteria have been waived by a school district representative for special unavoidable circumstances.

NEW SECTION

WAC 392-501-320 Application process. (1) The superintendent of public instruction shall make available to students and school district personnel a COE submission application for documenting that a student has met the eligibility requirements as set forth in WAC 392-501-310.

(2) It is the responsibility of the school district to determine whether the student is eligible for the COE option. If the student is eligible, the school district is required to inform the student of the COE alternative assessment option.

(3) If the student is eligible, the student, with the assistance of school district personnel, shall submit an application to the superintendent of public instruction via the Washington assessment management system (WAMS).

(4) The superintendent of public instruction will publish an annual calendar established before each school year setting forth the timelines for the twice yearly registration, sub-

mission, scoring, and student and district reporting for the COE.

NEW SECTION

WAC 392-501-330 Guidelines and protocols. (1) Specific guidelines for types and numbers of work samples for mathematics, reading, or writing will be published and made available to students, guardians, schools, and districts. The guidelines will be published on the office of the superintendent of public instruction (OSPI) web site at: <http://www.k12.wa.us/assessment/default> as approved by the state board of education in an open and public process.

(2) Protocols for submission of work samples will include a Student Information Form, a Work Sample Documentation Form, and Work Sample Sign-Off Forms. Protocols for submission of work samples will be published on the OSPI web site at <http://www.k12.wa.us/assessment/default> as approved by the state board of education in an open and public process.

NEW SECTION

WAC 392-501-340 Sufficiency process for all content areas. The following process will be utilized in determining sufficiency for a collection of evidence for one or more of the content areas submitted by a student. Upon receipt by OSPI, a collection of evidence will be reviewed to determine whether the protocols for submission have been met. OSPI will notify a school district of any missing paperwork or signatures. If the school district does not provide the missing paperwork or signatures within the time frame provided, the collection of evidence will be returned without a score.

NEW SECTION

WAC 392-501-350 Scoring process for all content areas. The following process will be utilized to determine a score for a submitted collection for one or more of the content areas.

(1) Collections shall be scored at the state level by a panel of educators screened, selected, and trained by OSPI. To be selected as a scorer, a person must be a certificated educator in the content area, provide teacher leadership at the building and/or district level, and work with high school students in the content area in which they teach.

(2) A submitted collection of evidence shall be scored in a rigorous process that aligns with state content standards and comparable WASL performance.

(3) Uniform scoring criteria will be published on the OSPI web site at <http://www.k12.wa.us/assessment/default> as approved by the state board of education in an open and public process.

NEW SECTION

WAC 392-501-360 Standard setting process for all content areas for the collection of evidence. (1) A neutral committee of educators, business people, and students will be trained on the state content standards in mathematics, reading, and writing. They will be led by an expert facilitator

trained in standard setting processes. The facilitator assists the standard setting committees in order to determine the cut score which all collections must attain in order to meet standard in one or more of the content areas.

(2) The standard setting committee will recommend a cut score for each content area to the state board of education for graduation purposes.

(3) The state board of education shall have the responsibility of accepting or not accepting the standard setting results, using an open and public process.

NEW SECTION

WAC 392-501-370 Reporting process for all content areas for the collection of evidence. Each student who prepared a collection of evidence will receive a report of his or her results within ninety days following scoring. The report will provide a detailed description of the level of performance on the state content standards found in the student collection. The report will state whether or not the student has met standard in the content area. The results shall be used for state high school graduation purposes.

NEW SECTION

WAC 392-501-380 Collection of evidence adherence to national standards. National Standards for Educational and Psychological Testing (AERA, NCME, APA, 1999) will be applied in all stages of the development and implementation of the collection of evidence in order to ensure reliability and validity of the alternative assessment option. The National Technical Advisory Committee for the superintendent of public instruction shall also provide ongoing technical assistance for the COE.

WSR 08-01-119

WITHDRAWAL OF PROPOSED RULES DEPARTMENT OF REVENUE

[Filed December 18, 2007, 3:52 p.m.]

The department of revenue has withdrawn its proposal to amend WAC 458-20-258 Travel agents and tour operators (Rule 258), filed on May 31, 2007, and published in the Washington state register as WSR 07-12-046. The department is drafting further changes and anticipates filing another CR-102 proposed rule making notice for Rule 258.

Alan R. Lynn
Rules Coordinator

WSR 08-01-127

PROPOSED RULES DEPARTMENT OF FINANCIAL INSTITUTIONS

(Securities Division)

[Filed December 19, 2007, 9:20 a.m.]

Original Notice.

Preproposal statement of inquiry was filed as WSR 07-19-067.

Title of Rule and Other Identifying Information: Amendments to WAC 460-16A-205 to update existing and adopt new North American Securities Administrators Association (NASAA) guidelines and statements of policy.

Hearing Location(s): Department of Financial Institutions, 150 Israel Road S.W., Tumwater, WA 98501, on January 23, 2008, at 10 a.m.

Date of Intended Adoption: January 23, 2008.

Submit Written Comments to: Jill M. Valley, Securities Division, P.O. Box 9033, Olympia, WA 98507-9033, e-mail jvalley@dfi.wa.gov, fax (360) 704-7035, by January 22, 2008.

Assistance for Persons with Disabilities: Contact Jill Valley by January 18, 2008, TTY (360) 664-8126 or (360) 902-8760.

Purpose of the Proposal and Its Anticipated Effects, Including Any Changes in Existing Rules: The Washington securities division uses guidelines and policies created by NASAA as the basis for regulating certain offerings and licensees. These guidelines and policies are periodically updated and occasionally new guidelines and policies are adopted. As part of the NASAA adoption process, all policies and guidelines are subjected to a public comment process. This amendment would update Washington's regulations to reflect the latest versions of all previously adopted guidelines. It would also adopt NASAA's statement of policy regarding church extension fund securities and uniform disclosure guidelines for cover legends for the first time. This will facilitate greater uniformity with the many other states that rely on NASAA guidelines and policies.

WAC 460-16A-205 (1)(b), (c), (d), (e), (f), (i), (j), and (q) would be amended to adopt the most recent version of the NASAA guideline codified in those subsections. New subsection (1)(y) would adopt "Church Extension Fund Securities" and new subsection (1)(z) would adopt "Guidelines for Cover Legends."

Statutory Authority for Adoption: RCW 21.20.450.

Statute Being Implemented: Chapter 21.20 RCW.

Rule is not necessitated by federal law, federal or state court decision.

Name of Proponent: Department of financial institutions, securities division, governmental.

Name of Agency Personnel Responsible for Drafting: Jill M. Valley, 150 Israel Road S.W., Tumwater, WA 98501, (360) 902-8760; Implementation: Scott Jarvis, Director of Department of Financial Institutions, 150 Israel Road S.W., Tumwater, WA 98501, (360) 902-8760; and Enforcement: Michael E. Stevenson, Director of Securities Division, 150 Israel Road S.W., Tumwater, WA 98501, (360) 902-8760.

No small business economic impact statement has been prepared under chapter 19.85 RCW. The proposal does not impose additional costs on business.

A cost-benefit analysis is not required under RCW 34.05.328. The department of financial institutions is not one of the agencies listed in RCW 34.05.328.

December 17, 2007

Scott Jarvis

Director

AMENDATORY SECTION (Amending WSR 02-22-106, filed 11/6/02, effective 12/7/02)

WAC 460-16A-205 Adoption of NASAA statements of policy. (1) In order to promote uniform regulation, the administrator adopts the following North American Securities Administrators Association (NASAA) statements of policy for offerings registering pursuant to RCW 21.20.180 or 21.20.210:

(a) Registration of publicly offered cattle feeding programs, as adopted September 17, 1980;

(b) Registration of commodity pool programs, as adopted with amendments through ~~((August 30, 1999))~~ May 7, 2007;

(c) Equipment programs, as adopted with amendments through ~~((October 24, 1991))~~ May 7, 2007;

(d) Registration of oil and gas programs, as adopted with amendments through ~~((October 24, 1991))~~ May 7, 2007;

(e) Real estate investment trusts, as adopted with amendments through ~~((September 29, 1993))~~ May 7, 2007;

(f) Real estate programs, as adopted with amendments through ~~((September 29, 1993))~~ May 7, 2007;

(g) Loans and other material affiliated transactions, as adopted with amendments through November 18, 1997;

(h) Options and warrants, as adopted with amendments through September 28, 1999;

(i) Registration of direct participation programs - omnibus guidelines, as adopted ~~((March 29, 1992))~~ with amendments through May 7, 2007;

(j) Mortgage program guidelines, as adopted ~~((September 10, 1996))~~ with amendments through May 7, 2007;

(k) Church bonds, as adopted April 14, 2002;

(l) Health care facility offerings, pertaining to the offering of nonprofit health care facility bonds, as adopted April 5, 1985;

(m) Corporate securities definitions, as adopted September 28, 1999;

(n) Impoundment of proceeds, as adopted with amendments through September 28, 1999;

(o) Preferred stock, as adopted with amendments through April 27, 1997;

(p) Promotional shares, as adopted September 28, 1999, except that the term promotional shares shall be limited to those equity securities which were issued within the last three years and that all promotional shares in excess of twenty-five percent of the shares to be outstanding upon completion of the offering may be required to be deposited in escrow absent adequate justification that escrow of such shares is not in the public interest and not necessary for the protection of investors;

(q) Registration of asset-backed securities, as adopted ~~((October 25, 1995))~~ with amendments through May 7, 2007, except for offerings registering or required to register pursuant to chapter 460-33A WAC or RCW 21.20.705 through 21.20.855;

(r) Promoters' equity investment, as adopted with amendments through April 27, 1997;

(s) Specificity in use of proceeds, as adopted September 28, 1999;

(t) Underwriting expenses, underwriter's warrants, selling expenses, and selling security holders, as adopted with amendments through September 28, 1999;

(u) Unsound financial condition, as adopted September 28, 1999;

(v) Unequal voting rights, as adopted October 24, 1991;

(w) Guidelines for general obligation financing by religious denominations, as adopted April 17, 1994; ~~((and))~~

(x) Risk disclosure guidelines, as adopted September 9, 2001;

(y) Church extension fund securities, as adopted with amendments through April 18, 2004; and

(z) Guidelines for cover legends as adopted October 2, 2004.

(2) An offering registering pursuant to RCW 21.20.180 or 21.20.210 that falls within one or more of the statements of policy listed in subsection (1) of this section must comply with the requirements of said statement of policy or policies.

(3) The statements of policy referred to in subsection (1) of this section are found in *CCH NASAA Reports* published by Commerce Clearing House. Copies are also available at the office of the securities administrator.

WSR 08-01-132

PROPOSED RULES

PUBLIC DISCLOSURE COMMISSION

[Filed December 19, 2007, 9:50 a.m.]

Continuance of WSR 07-21-042 [and 07-22-042].

Preproposal statement of inquiry was filed as WSR 07-16-001.

Title of Rule and Other Identifying Information: Amend WAC 390-05-400 Changes to dollar amounts as prescribed in RCW 42.17.690.

Hearing Location(s): Commission Hearing Room, 711 Capitol Way, Room 206, Olympia, WA 98504, on January 24, 2008, at 9:30 a.m.

Date of Intended Adoption: January 24, 2008.

Submit Written Comments to: Doug Ellis, Public Disclosure Commission, P.O. Box 40908, Olympia, WA 98504-0908, e-mail dellis@pdc.wa.gov, fax (360) 753-1112, by January 21, 2008.

Assistance for Persons with Disabilities: Contact Kami Madsen by phone (360) 586-0544.

Purpose of the Proposal and Its Anticipated Effects, Including Any Changes in Existing Rules: To reschedule the time for a public hearing to January 24, 2008.

Statutory Authority for Adoption: RCW 42.17.370(1) and 42.17.690.

Statute Being Implemented: RCW 42.17.640 and 42.17.645.

Rule is not necessitated by federal law, federal or state court decision.

Name of Proponent: Public disclosure commission, governmental.

Name of Agency Personnel Responsible for Drafting and Implementation: Doug Ellis, 711 Capitol Way, Room 206, Olympia, WA 98504, (360) 664-2735; and Enforce-

ment: Phil Stutzman, 711 Capitol Way, Room 206, Olympia, WA 98504, (360) 664-8853.

No small business economic impact statement has been prepared under chapter 19.85 RCW.

December 19, 2007

Vicki Rippie

Executive Director

WSR 08-01-134

PROPOSED RULES

DEPARTMENT OF HEALTH

[Filed December 19, 2007, 10:03 a.m.]

Original Notice.

Exempt from preproposal statement of inquiry under RCW 34.05.310(4).

Title of Rule and Other Identifying Information: WAC 246-976-021 Emergency medical services (EMS) training course requirements. This section establishes responsibilities for approved emergency medical services training agencies and programs to provide department-required EMS training courses. This section also establishes the department's responsibility to identify training course requirements for all EMS training agencies and programs that train EMS personnel who are credentialed by the department.

Hearing Location(s): Department of Health, Point Plaza Building, Rooms 152 and 153, 310 Israel Road S.E., Tumwater, WA 98501, on January 22, 2008, at 10:00 a.m.

Date of Intended Adoption: January 23, 2008.

Submit Written Comments to: Maura Craig, Department of Health, P.O. Box 47850, Olympia, WA 98504-7850, web site <http://www3.doh.wa.gov/policyreview/>, fax (360) 236-2830, by January 22, 2008.

Assistance for Persons with Disabilities: Contact Maura Craig by January 18, 2008, TTY (800) 833-6388 or 711.

Purpose of the Proposal and Its Anticipated Effects, Including Any Changes in Existing Rules: ESB 6194, passed in 2006 and codified as RCW 43.70.615, requires that each education program with a curriculum to train persons for a health profession credentialed under chapter 18.130 RCW must integrate multicultural health education into its training by July 1, 2008. The proposed rule requires EMS training programs to include a multicultural health education component in order to comply with the law.

Reasons Supporting Proposal: The proposed rule requires EMS training agencies to incorporate multicultural health education into all initial EMS training by July 1, 2008, for all levels of EMS personnel credentialed by the department. The purpose of the multicultural health training is to raise awareness and educate health care personnel to care for diverse populations in a culturally sensitive and appropriate manner. The goal is to increase access to health care and achieve positive health outcomes for all populations regardless of gender, race, or ethnicity.

Statutory Authority for Adoption: RCW 18.71.205, 18.73.081, 43.70.615.

Statute Being Implemented: RCW 43.70.615.

Rule is not necessitated by federal law, federal or state court decision.

Name of Proponent: Department of health, office of emergency medical services and trauma system, governmental.

Name of Agency Personnel Responsible for Drafting: Maura Craig, 310 Israel Road S.E., Tumwater, WA 98501, (360) 236-4987; Implementation and Enforcement: Michael Lopez, 243 Israel Road S.E., Tumwater, WA 98501, (360) 236-2841.

No small business economic impact statement has been prepared under chapter 19.85 RCW. A small business economic impact statement is not required because this rule proposal is exempt under RCW 19.85.025 and 34.05.310(4). The proposed rule adopts language from state law, RCW 43.70.615, without material change.

A cost-benefit analysis is not required under RCW 34.05.328. This rule proposal is exempt under RCW 34.05.-328 (5)(b)(iii). The proposed rule adopts language from a state law, RCW 43.70.615, without material change.

December 19, 2007

Mary C. Selecky

Secretary

AMENDATORY SECTION (Amending WSR 03-20-107, filed 10/1/03, effective 11/1/03)

WAC 246-976-021 Training course requirements. (1) **Department responsibilities:** The department will publish procedures for agencies to conduct EMS training courses, including:

- (a) The registration process;
- (b) Requirements, functions, and responsibilities of course instructional and administrative personnel;
- (c) Necessary information and administrative forms to conduct the course;

(2) **Training agency responsibilities:**

(a) **General.** Agencies providing initial training of certified EMS personnel at all levels (except advanced first aid) must:

- (i) Have MPD approval for the course content;
- (ii) Have MPD approval for all instructional personnel, who must be experienced and qualified in the area of training;
- (iii) Have local EMS/TC council recommendation for each course;
- (iv) Have written approval from the department to conduct each course;
- (v) Approve or deny applicants for training consistent with the prerequisites for applicants in WAC 246-976-041 and 246-976-141.

(b) **Basic life support** (first responder, EMT). Agencies providing initial training of basic life support personnel must identify a senior EMS instructor to be responsible for the quality of instruction and the conduct of the course.

(c) **Intermediate life support** (IV, airway and ILS technicians). Agencies providing initial training of intermediate life support personnel must:

- (i) Have a written agreement with the clinical facility, if it is separate from the academic facility;

(ii) Ensure that clinical facilities provide departments or sections, personnel, and policies, including:

(A) Written program approval from the administrator and chief of staff;

(B) A written agreement to participate in continuing education;

(C) Supervised clinical experience for students during the clinical portion of the program;

(D) An orientation program.

(d) **Paramedics.** Agencies training paramedics must be accredited by a national accrediting organization approved by the department.

(3) **Course curriculum.** The department recognizes the following National Standard EMS training courses published by the United States Department of Transportation as amended by the department:

(a) First responder: The first responder training course published 1996, amended by the department March 1998;

(b) EMT: The emergency medical technician—Basic training course published 1994, amended by the department September 1996;

(c) IV technician: Those sections and lessons identified in the emergency medical technician—Intermediate course published 1999, amended by the department April 2000;

(d) Airway technician: Those sections and lessons identified in the emergency medical technician—Intermediate course published 1999, amended by the department April 2000;

(e) ILS technician: Those sections and lessons identified in the emergency medical technician—Intermediate course published 1999, amended by the department April 2000 which includes the following medications:

(i) Epinephrine for anaphylaxis administered by a commercially preloaded measured-dose device;

(ii) Albuterol administered by inhalation;

(iii) Dextrose 50% and 25%;

(iv) Nitroglycerine, sublingual and/or spray;

(v) Naloxone;

(vi) Aspirin PO (oral), for suspected myocardial infarction;

(f) Paramedic: The emergency medical technician—Paramedic training course published 1999, as amended by the department January 2000.

(4) Initial training for first responders and EMTs must also include approved infectious disease training that meets the requirements of chapter 70.24 RCW.

(5) By July 1, 2008, a multicultural health education and awareness instructional component or curriculum shall be included in each initial preparation training course for all EMS personnel. All multicultural health education and awareness trainings, instruction, and curricula shall meet the requirements set forth in RCW 43.70.615.

(6) Specialized training. The department, in conjunction with the advice and assistance of the L&C committee, may approve specialized training for certified EMS personnel to use skills, techniques, or equipment that is not included in standard course curricula. Agencies providing specialized training must have MPD and department approval of:

(a) Course curriculum;

(b) Lesson plans;

(c) Course instructional personnel, who must be experienced and qualified in the area of training;

(d) Student selection criteria;

(e) Criteria for satisfactory completion of the course, including student evaluations and/or examinations;

(f) Prehospital patient care protocols that address the specialized skills.

~~((6))~~ (7) Local government agencies: The department recognizes county agencies established by ordinance and approved by the MPD to coordinate EMS training. These agencies must comply with the requirements of this section.

WSR 08-01-135

PROPOSED RULES

DEPARTMENT OF HEALTH

[Filed December 19, 2007, 10:08 a.m.]

Original Notice.

Preproposal statement of inquiry was filed as WSR 06-07-033.

Title of Rule and Other Identifying Information: Adopting new chapter 246-225A WAC, Radiation safety and diagnostic image quality standards for dental facilities, and repealing WAC 246-225-110 Intraoral dental radiographic systems.

Hearing Location(s): DOH Marketing Center, Creekside Three at CenterPoint, 20435 72nd Avenue South, Suite 200, Conference Room 1, Kent, WA 98032, on February 6, 2008, at 2:00 p.m.

Date of Intended Adoption: February 7, 2008.

Submit Written Comments to: Ellen Haars, Office of Radiation Protection, P.O. Box 47827, Olympia, WA 98504-7827, web site <http://www3.doh.wa.gov/policyreview/>, fax (360) 236-2266 by February 6, 2008.

Assistance for Persons with Disabilities: Contact Phyllis Hurtado by February 1, 2008, TTY (800) 833-6388 or 711.

Purpose of the Proposal and Its Anticipated Effects, Including Any Changes in Existing Rules: This rule revision will create a separate, user-friendly chapter for dentists using X-ray machines. This rule is needed to make it easier for the dental community to find and comply with pertinent regulations and incorporates outcome-based regulations as appropriate. Specific changes include requiring quality assurance for X-ray film processing and disallowing use of low kilovolts peak (kVp) (higher exposure) dental X-ray machines. These changes, along with reinforcing the current prohibition of hand-held X-ray units, will limit unnecessary higher radiation exposure to patients.

Reasons Supporting Proposal: This chapter defines the regulatory standards for dental X-ray radiation safety. Adopting clear language and specific requirements will improve operator and patient safety. Adding quality assurance requirements for X-ray film processing will improve the quality of the X-ray film and reduce the need for unnecessary exposure to radiation due to X-ray retakes. Disallowing use of the older, low kVp dental X-ray machines, which deliver higher doses of radiation, will limit unnecessary higher radiation exposure to patients.

Statutory Authority for Adoption: RCW 70.98.050 and 70.98.080.

Statute Being Implemented: RCW 70.98.050 and 70.98.080.

Rule is not necessitated by federal law, federal or state court decision.

Name of Proponent: Department of health, governmental.

Name of Agency Personnel Responsible for Drafting, Implementation and Enforcement: Ellen Haars, P.O. Box 47827, Olympia, WA 98504-7827, (360) 236-3231.

A small business economic impact statement has been prepared under chapter 19.85 RCW.

Small Business Economic Impact Statement

1. Briefly Describe the Proposed Rule: The current chapter 246-225 WAC contains rules and standards for all professions using X-ray machines in the healing arts. As such, it has been difficult for practitioners to get a clear understanding of the rules applying to their specific practice type. This rule making will create a separate user-friendly chapter for dentists with emphasis placed on improved patient safety and quality assurance. In addition, the department of health (department) proposes to:

a. Disallow the use of low fifty kVp machines that unnecessarily increase radiation exposure to patients and staff; and

b. Require periodic monitoring of image processors in dental X-ray so that consistent, high quality radiographic quality is achieved. This is expected to reduce the number of X-ray retakes and unnecessary exposure to patients and dental staff.

The proposed rule also repeals WAC 246-225-110 Intraoral dental radiographic systems.

2. Is a Small Business Economic Impact Statement (SBEIS) Required for this Rule? Yes. Washington state has approximately 2,950 dental facilities using around 11,000 X-ray machines, and all of them qualify as small businesses according to the definition (less than fifty employees). It should be noted that even though all dental facilities are categorized as "small businesses," some are smaller than others. For example, one might find a rural dentist practicing with only one X-ray machine, or larger facilities staffed with a few dentists, a large number of assistants and hygienists, and six to ten machines. There will be an impact on some facilities that have fifty kVp X-ray units since they will have to dispose of these and purchase newer equipment of higher kVp. In addition, all facilities will have to implement the periodic monitoring of film processors whether they have one machine or many, but the cost of implementing this quality control is so small that there will be little impact on a small dental facility versus a large one.

3. Which Industries Are Affected by this Rule? Dentists, SIC code 8021.

4. What are the costs of complying with this rule for small businesses (those with fifty or fewer employees) and for the largest 10% of businesses affected?

a. Proposed WAC 246-225A-080, prohibiting low kVp X-ray machines. For the machines that operate at fifty kVp, 128 out of 2,900 facilities have such a machine. Each

machine replacement would cost about \$4,500 if purchased new; however, many higher kVp machines are available on the used equipment market and are reasonable options. Used machines would cost around \$2,500. It is estimated that most affected dental businesses will be able to amortize this equipment over at least three years, so the highest annual cost would be between \$833 (used) to \$1,500 (new) per year. Note that most fifty kVp machines have been in use for over twenty years, so their initial cost has been recovered many times over, and a new machine's cost can be amortized over several years.

b. Proposed WAC 246-225A-110, requiring weekly monitoring of image processors. For the requirement of quality control on image processing, all facilities would have to devote some staff time to making the required periodic tests. The estimated time for this activity is fifteen minutes per week. The department assumes that the duties would be performed by a dental assistant. The average salary of a dental assistant is \$16.64 per hour plus payroll taxes and benefits; therefore, each facility would be expected to spend \$4.16 per week, or \$213.32 plus payroll taxes and benefits per year. This would be the case for around 80% of dental facilities that use traditional film and chemical-based film processors. Several options are available for performing the required image quality control tests; one is a small test tool that costs \$30. A more expensive option is a combination of a densitometer and a sensitometer that together cost approximately \$2,000. These options would both be one-time costs. The remaining 20% of dental offices use digital imaging and a standard quality control test is not available at this time.

5. Does the Rule Impose a Disproportionate Impact on Small Businesses? There is no disproportionate impact because all the businesses regulated by this proposed rule are small. However, because all the businesses are small and yet vary in size, the impact upon them was considered while developing the rule and efforts were made to limit that impact. Establishing performance based regulation for periodic quality control testing of image processors that allow the use of inexpensive devices is included in the proposed rule to limit the impact to small businesses. Therefore, not even the very small facilities regulated by this proposed rule will have a disproportionate burden placed upon them.

6. If the Rule Imposes a Disproportionate Impact on Small Businesses, What Efforts Were Taken to Reduce That Impact (or Why Is it Not "Legal and Feasible" to Do So) By:

a) **Reducing, modifying, or eliminating substantive regulatory requirements?** Not applicable.

b) **Simplifying, reducing, or eliminating record-keeping and reporting requirements?** Not applicable.

c) **Reducing the frequency of inspections?** Not applicable.

d) **Delaying compliance timetables?** Because we recognize all dental facilities are small businesses, we delayed compliance for replacement of the low kVp dental X-ray units as well as periodic monitoring of image processors until July 1, 2008.

e) **Reducing or modifying fine schedules for noncompliance?** Not applicable.

f) **Any other mitigation techniques?** Not applicable.

7. Will Compliance with the Proposed Rule Cause Affected Businesses to Create or Lose Jobs? An estimated one hundred twenty-eight dental businesses would need to replace old fifty kVp X-ray machines under this proposed rule, at an estimated cost for a new seventy kVp machine of \$4,500, or about \$2,500 for a used seventy kVp machine. It is estimated that most affected dental businesses will be able to amortize this equipment over at least three years, so the highest annual cost would be between \$833 (used) to \$1,500 (new) per year. These costs would not be expected to cause an affected business to create or lose jobs.

Some dental businesses may choose to pay cash for a new seventy kVp X-ray machine. In those cases, it is possible that those businesses may need to consider reducing employment by 0.15 to 0.25 full-time positions, depending on the affected position(s) for one year to offset the one-time cost of a seventy kVp X-ray machine.

Quality improvement testing costs under the proposed rule are low, and are not expected to cause affected businesses to create or lose jobs.

8. How Are Small Businesses Involved in the Development of this Rule? A fifteen-member workgroup reviewed an initial staff proposal. Department of health, office of radiation protection staff held meetings with members of the dental quality assurance commission and the Washington state dental association. Proposed changes were also posted on the dental quality assurance commission list-serve for review and comment. Dental X-ray registrants, the University of Washington Dental School, X-ray stakeholders, and interested parties were invited to participate in an ad-hoc workgroup for comments and discussion on the informal rule draft. Comments received as a result of these activities were considered and incorporated as appropriate.

A copy of the statement may be obtained by contacting Phyllis Hurtado, Office of Radiation Protection, X-ray Program, P.O. Box 47827, Olympia, WA 98504-7827, phone (360) 236-3239, fax (360) 236-2266, e-mail phyllis.hurtado@doh.wa.gov.

A cost-benefit analysis is required under RCW 34.05.328. A preliminary cost-benefit analysis may be obtained by contacting Phyllis Hurtado, Office of Radiation Protection, X-ray Program, P.O. Box 47827, Olympia, WA 98504-7827, phone (360) 236-3239, fax (360) 236-2266, e-mail phyllis.hurtado@doh.wa.gov.

December 19, 2007

Mary C. Selecky
Secretary

REPEALER

The following section of the Washington Administrative Code is repealed:

WAC 246-225-110	Intraoral dental radiographic systems.
-----------------	--

Chapter 246-225A WAC

RADIATION SAFETY AND DIAGNOSTIC IMAGE QUALITY STANDARDS FOR DENTAL FACILITIES

NEW SECTION

WAC 246-225A-001 Purpose and scope. This chapter establishes facility design and operation requirements for the use of dental X-ray equipment according to chapter 70.98 RCW. The scope of this chapter pertains to dental intra-oral and extra-oral radiography and establishes radiation safety requirements for patients, dental employees, and the public; and establishes optimal diagnostic image processing requirements.

NEW SECTION

WAC 246-225A-010 Definitions. As used in this chapter, the following definitions apply:

"Barrier" (see "protective barrier").

"Beam" (see "X ray").

"Beam-limiting device," sometimes called a collimator or cone, means a device that controls the size of the X-ray field.

"Cephalometric" means X-ray imaging specific to the human head and jaw.

"Computed radiography (CR)" means creating an X-ray image using plates consisting of a special phosphor that when exposed to radiation and then processed by a scanner, provides the information to a computer for display and manipulation.

"Computed tomography (CT)" means creating a cross-sectional X-ray image generated by an X-ray source and detector moving around the patient's body.

"Control panel" means the part of the X-ray system where the switches, knobs, pushbuttons, and other hardware necessary to operate the X-ray system are located.

"Dead-man switch or button" means a switch designed so that it can only be operated by continuous pressure on the switch by the operator, and when released before the preset exposure time will stop the exposure.

"Department" means the department of health, which is the state radiation control agency under chapter 70.98 RCW.

"Detector" means a device capable of receiving and recording an X-ray image.

"Direct digital radiography (DR)" means creating an X-ray image by sending signals directly from a solid state detector to a computer for display and manipulation.

"Diagnostic source assembly" means the combination of the tube housing assembly and the collimator.

"Direct scattered radiation" means radiation discharged in a straight line from the object being radiographed.

"Exposure," as the context implies, means:

(a) The number of electrons, measured in coulombs per kilogram of air, released through the ionization of air molecules by electromagnetic radiation; and

(b) An occupational worker or patient being subjected to radiation either directly or indirectly.

"Extra-oral radiography" means creating a film or digital X-ray image on an image receptor placed outside the mouth. Examples include panoramic and cephalometric X rays.

"Filter" means material, such as copper or aluminum, placed in the useful beam of the X ray to block selected energies, and in a safelight to block light that could fog the X-ray film.

"Focal spot" means the area on the anode end of the X-ray tube bombarded by the electrons accelerated from the cathode and from which the useful X-ray beam begins.

"Grid" means a device placed between the patient and the image receptor in extra-oral radiography that reduces scattered radiation that would decrease the quality of the image being created.

"Half-value layer (HVL)" means the thickness of material that reduces the intensity of radiation to one-half of its original value.

"Healing arts screening" means using X-ray equipment without an order by a licensed practitioner on an individual who does not have a known or diagnosed disease or symptom to learn if the individual may have an indication of ill health.

"Image receptor" means a device that transforms an X-ray beam into a visible film or digital image.

"Intra-oral radiography" means creating a film or digital X-ray image on an image receptor placed inside the mouth.

"Kilovolt (kV)" means the unit used to measure electrical energy.

"Kilovolts peak (kVp)" means the highest possible voltage across the X-ray tube during an exposure (see also "peak tube potential").

"Leakage radiation" means radiation coming from the X-ray tube, other than the main X-ray beam.

"Leakage technique factors" means the technique factors associated with the tube housing assembly that are used to measure leakage radiation. They are defined as the maximum rated peak tube potential and the maximum rated continuous tube current at the maximum peak tube potential.

"Licensed practitioner" means an individual who holds a license to practice dentistry under chapter 18.32 RCW.

"Milliampere (mA)" means the unit used to measure electrical current in an X-ray tube.

"Milliampere second (mAs)" means the product of the electrical current in the X-ray tube in milliamperes and the time of exposure in seconds.

"Mobile equipment" (see "X-ray system").

"Operator" means a person working under the direction of a licensed practitioner to operate X-ray equipment and who has been properly trained according to WAC 246-225A-020.

"Operatory" means a room in which dental health care procedures are performed.

"Peak tube potential" means the maximum voltage in the X-ray tube during an exposure.

"Portable equipment" (see "X-ray equipment").

"Position-indicating device" means a device on X-ray equipment that shows where the X-ray beam will be directed and establishes the distance from the X-ray tube to the patient's body. The device may or may not incorporate or serve as a beam-limiting device.

"Primary beam" (see "useful beam").

"Primary protective barrier" means the material placed in the useful beam, beyond the patient and image receptor, to reduce remnant primary beam exposure.

"Protected area" means a space for X-ray equipment operators that is shielded so that X-ray exposures are reduced enough to meet the exposure limits of WAC 246-221-010 (Occupational dose limits for adults) and WAC 246-220-007 (Statement of philosophy). In addition, the space must have no exposure to direct scattered radiation.

"Protective apron" means a garment made of radiation absorbing materials used to reduce a person's radiation exposure.

"Protective barrier" means a structure made of radiation absorbing material used to reduce radiation exposure.

"Quality assurance" means a program designed to produce high quality X-ray images at minimal cost and with minimal patient exposure to radiation.

"Quality control" means the regular testing of X-ray equipment and associated equipment, such as processors, to verify that the equipment is working properly. Controls include performing routine tests of the diagnostic X-ray imaging system such as X-ray beam output, viewing X-ray test images, and continually adjusting the performance of the X-ray equipment and processor to an optimal and consistent level.

"Radiation safety" means ways to protect patients and staff from unnecessary radiation exposure. Safety measures may include patient exposure reduction, image quality improvement, diagnostic imaging system quality assurance, radiation measurements, dose evaluations, compliance with state and federal regulations, and related issues.

"Radiographic" means the production of an image created when an X-ray pattern exits an X-rayed object.

"Radiography" means a way of creating a permanent film or digital image using X rays.

"Recording" means creating a permanent image, on film or in a computer, from an X-ray exposure.

"Registrant" means the owner or controller of the radiation equipment who is responsible for the safe operation of the radiation equipment in accordance with this chapter and chapter 70.98 RCW.

"Registration" means providing required information and continuing contact with the department.

"Remnant primary beam" means the part of the useful beam that completely passes through the patient and image receptor.

"Safelight" means a lamp with a filter that is used in an X-ray darkroom to provide enough light to see, but not enough to over-expose the film.

"Scattered radiation" means radiation that has changed direction as it passes through matter (see also "direct scattered radiation").

"Secondary protective barrier" means an object or material sufficient to reduce stray radiation to the required degree as stated in chapter 246-221 WAC (Radiation protection standards).

"Source-to-image-receptor distance (SID)" means the distance from the focal spot in the X-ray tube to the center of the surface of the image receptor.

"Source" means the focal spot of the X-ray tube.

"Source-to-skin distance (SSD)" means the distance between the focal spot of the X-ray tube and the nearest point on the patient's skin where the primary beam enters.

"Stationary equipment" (see "X-ray system").

"Stray radiation" means the sum of leakage and scattered radiation.

"Technique chart" means a written instruction or guide that X-ray equipment operators use to determine which radiation technique factors to select for each type of radiographic examination.

"Technique factors" means the X-ray system settings selected for a given radiographic examination. They are specified as the peak tube potential in kilovolts and either:

(a) Tube current measured in milliamperes and exposure time in seconds or pulses; or

(b) The product of tube current and exposure time expressed in milliamperere seconds.

"Tube" means a glass tube that produces an X ray when high-voltage electricity is passed between the cathode at one end and the anode at the other.

"Tube housing assembly" means the X-ray tube and its housing. It includes high-voltage and/or filament transformers and other appropriate elements when they are contained within the tube housing.

"Tube housing port" means the portion of the tube housing assembly that the X rays pass through.

"Useful beam" means the radiation that passes through the tube housing port and the opening of the beam-limiting device.

"Variance" means a department-authorized alternative to a requirement of this chapter.

"X ray" means a beam of ionizing radiation produced by a machine.

"X-ray control" means a device that controls how much electricity enters the X-ray high-voltage generator and/or the X-ray tube. It includes equipment that controls the technique factors for an exposure.

"X-ray equipment" means the entire X-ray system or parts of the system.

"X-ray exposure switch or button" means the part of the X-ray system that when engaged generates the production of an X ray. (See also "dead-man switch or button.")

"X-ray high-voltage generator" means a device that supplies electrical energy to the X-ray tube to create an X-ray beam.

"X-ray system" means all of the components of a machine used for the controlled production of X rays. It includes minimally an X-ray high-voltage generator, an X-ray control, a tube housing assembly, a beam-limiting device, and the necessary supporting structures. Additional components which function with the system, such as the image receptor, are considered integral parts of the system. Types of X-ray systems are:

(a) "Mobile" means X-ray equipment mounted on a permanent base with wheels and/or casters for moving the X-ray equipment fully assembled. It is intended to be taken from one geographical location to another or from one room to another.

(b) "Portable" means X-ray equipment designed to be hand-carried, but not hand-held during use.

(c) "Stationary" means X-ray equipment that is installed in a fixed location, such as bolted to a floor or wall.

"X-ray tube" means any electron tube which is designed to be used primarily for the production of X rays.

NEW SECTION

WAC 246-225A-020 General requirements and administrative controls. The registrant is responsible for directing the operation of the X-ray system and assuring the provisions of WAC 246-222 (Radiation protection—Worker rights) are met. In addition, the registrant shall:

(1) Verify that any operator of the X-ray equipment is trained and able to show that he or she can correctly and safely operate the X-ray equipment used by the registrant. The department may determine compliance by observation, interview, and/or testing in these subject areas:

(a) Knowledge of the X-ray system controls and their function;

(b) Knowledge of radiation safety and shielding methods for both operators and patients;

(c) Proper image processing.

(2) Post a technique chart at each X-ray system's control panel that specifies the following information for the examinations being performed by that system:

(a) Patient's teeth, jaw, or head anatomy versus technique factors to be used;

(b) If applicable, settings for automatic exposure devices; and

(c) The type and size of screen-film combination or other imaging system to be used.

(3) Require that all individuals, other than the patient being examined:

(a) Be positioned so that no part of the body, including the extremities, will be struck by the useful beam;

(b) Be protected from stray radiation by wearing protective aprons or by being positioned behind protective barriers of not less than 0.25 millimeters lead equivalent; and

(c) Not be present in the room during the X-ray exposure, except as described in subsection (4)(b) of this section.

(4) Use mechanical holding devices when a patient, film, or image receptor needs to be supported during an X-ray exposure when the technique permits.

(a) No individual shall be allowed to routinely hold a patient, film, or image receptor; and

(b) Holding a patient, film, or image receptor shall only be allowed in very unusual and rare situations. In these cases the patient's name, the date, and the name of the person holding the patient must be recorded in writing and maintained by the registrant for at least five years.

(5) Comply with the occupational exposure limits and the requirements for the determination of prior occupational dose stated under WAC 246-221-020 (Determination of prior occupational dose) for all individuals associated with the operation of the registrant's X-ray system. In addition, when protective clothing or devices are worn on portions of the body and a dosimeter is required, at least one dosimeter shall be used and documented as follows:

(a) When an apron is worn, the dosimeter shall be worn at the collar outside the apron;

(b) The dose to the whole body based on the maximum dose attributed to the most critical organ must be recorded on the reports required under WAC 246-221-230 (Records important to radiation safety). If more than one dosimeter is worn, each dose must be identified with the area where the dosimeter was worn on the body.

(6) Require personnel dosimetry monitoring of an operator when:

(a) Mobile or portable X-ray systems are used, i.e., when X-ray exposure buttons or X-ray exposure switch cords are used that allow the operator to stand in an unprotected area during exposures; or

(b) Measurements by the department show ten percent of the exposure limits as specified under WAC 246-221-010 (Occupational dose limits for adults) are exceeded.

(7) Use only X-ray equipment, and the accessories used in connection with making X rays, that meet the requirements of this chapter.

(8) Not allow anyone in the dental office to operate X-ray equipment for diagnostic purposes when the X-ray equipment:

(a) Does not meet the provisions of this chapter; or

(b) Is malfunctioning or threatens the health or safety of a patient, dental employee, or the public.

(9) Not allow patients to be exposed to the useful X-ray beam except for healing arts purposes. Only a licensed practitioner may authorize an exposure to the useful beam. Deliberate exposure of an individual for the following purposes is prohibited:

(a) Training, demonstration, or other purposes unless there are also healing arts requirements and proper prescription provided; or

(b) Except for exposure required under Medicare provisions, any exposure for which the sole purpose is satisfying a third party's prerequisite for reimbursement under any health care plan.

NEW SECTION

WAC 246-225A-025 X-ray system radiation safety procedure. If required by the department, the registrant shall adopt a written X-ray system radiation safety procedure.

(1) The department may require an X-ray system radiation safety procedure if there is reason to believe the registrant needs increased attention because of:

(a) Poor operator staff training;

(b) Extremely high workload;

(c) Increased risk of exposure due to staff supporting patients during radiography;

(d) Increased risk of exposure to scattered radiation;

(e) Unnecessarily high patient exposure values; or

(f) Other similar conditions.

(2) The X-ray system radiation safety procedures shall:

(a) Address patient and occupationally exposed personnel safety; and

(b) Define any restrictions of the operating technique required for safe operation of the X-ray system.

NEW SECTION

WAC 246-225A-026 Healing arts screening program. Any individual proposing to conduct a healing arts screening program shall obtain approval from the state health officer as required in WAC 246-225-99930 before conducting the screening program.

NEW SECTION

WAC 246-225A-030 Prohibited equipment. Registrants shall use only mobile or stationary X-ray equipment as defined in WAC 246-225A-010 for intra-oral or extra-oral radiography. Registrants shall not use:

(1) X-ray systems designed to be hand-held during exposures of human patients; or

(2) Dental fluoroscopy without electronic amplification.

NEW SECTION

WAC 246-225A-040 Dental X-ray rule variance request. A registrant may submit a written request to the department for a variance from the applicable regulations. The registrant shall not use X-ray equipment on patients until the department approves the variance request.

(1) The written request shall be addressed to: X-ray Supervisor, Office of Radiation Protection, Department of Health, P.O. Box 47827, Olympia, Washington 98504-7827, and must include:

(a) The specific WAC reference or references of the rule for which the variance is requested;

(b) An explanation of the circumstances involved, and the reason why the rule cannot be followed;

(c) A description of how the proposed alternative meets the intent of the rule and how the registrant shall protect patients, dental employees, and the public;

(d) A description of the X-ray system to be used with supporting pictures or documents; and

(e) The time period for which the variance is requested.

(2) The department may impose conditions that may be necessary to protect human health and safety during the term of the variance.

(3) If necessary, the department may require the registrant to submit additional information.

(4) The department may conduct an on-site variance inspection to verify the information provided or if it determines that an inspection is necessary.

(5) As determined by the department, variances can be permanent or temporary.

(6) The department may at any time revoke a variance if it is determined that the conditions of the variance are not being followed.

NEW SECTION

WAC 246-225A-050 Dental X-ray facility design. All registrants proposing to use X-ray equipment designed to produce computed tomography images using a "ring detector" type CT, or where medical X-ray systems are used for dental imaging, shall submit shielding and floor plans to the department for review. The submittal shall be based on the

criteria and methods found in National Council on Radiation Protection and Measurements (NCRP) report #147, issued November 19, 2004. The intent of this requirement is to assure protection of patients, dental employees, and the public. A copy of this report is available for review at Department of Health, Office of Radiation Protection, 111 Israel Road S.E., Tumwater, Washington. Shielding and floor plans shall meet the following requirements:

(1) Each X-ray exposure switch or button shall be located to meet the following criteria:

(a) For stationary X-ray systems, the X-ray exposure switch or button shall be permanently mounted in a protected area (such as a corridor outside the room) so that the operator can make an exposure only from the protected area; and

(b) Mobile X-ray systems shall have an X-ray exposure switch or button located at the end of a cord at least twelve feet (3.7 meters) long.

(2) Shielding for cephalometric X ray shall meet the following criteria:

(a) Be at least one foot (30.5 centimeters) larger, in both the horizontal and vertical directions, than the area of the primary beam where it strikes the nearest wall; and

(b) Shielding between the nearest wall struck by the primary beam and the next occupied area shall have two-pound lead or equivalent installed in the wall (based on 20 films per week). Exterior walls or concrete block walls need no additional shielding.

(3) Acceptable shielding materials for dental X-ray facilities are as follows:

(a) The minimum shielding for intra-oral stray radiation protection is standard gypsum wallboard/sheetrock construction (two layers each of five-eighths inch thickness).

(b) Where windows are provided to observe patients during radiography, the windows are at least one-half inch plate glass, or equivalent ability to reduce exposure.

(c) All other materials used for shielding between operatories and for operator protection areas are equivalent to 0.2 millimeters of lead.

(4) Barriers between dental X-ray rooms and dental operatories where intra-oral X-ray equipment is installed shall meet the following criteria:

(a) Be at least six feet (1.83 meters) high and composed of materials capable of reducing scattered radiation as required under subsection (3) of this section;

(b) There shall be no line of sight between workers or patients in one operatory and the X-ray tube housing assembly in the next operatory when that X-ray tube housing assembly is in its operating position;

(c) X-ray tube housing assemblies shall not be mounted between operatories on top of barriers less than six feet (1.83 meters) high, unless those barriers are at the foot end of the patient couches, and there is no line of sight between operatories.

NEW SECTION

WAC 246-225A-060 General requirements for all dental X-ray systems. Registrants shall use only dental X-ray systems and medical X-ray systems for dental imaging that meet the following requirements:

(1) The leakage radiation from the tube housing assembly, measured at a distance of one meter in any direction from the source, shall not exceed 100 milliroentgens in one hour when the X-ray tube is operated at its leakage technique factors. The department will determine compliance by measuring leakage averaged over an area of 100 square centimeters with no dimension of that area greater than 20 centimeters.

(2) The half-value layer of the useful beam for a given X-ray tube potential shall not be less than the values shown in Table 1 of this section. To determine a half-value layer at an X-ray tube potential which is not listed in Table 1 of this section, linear interpolation or extrapolation may be made.

Table 1

Design operating range (kilovolts peak)	Measured potential (kilovolts peak)	Half-value layer (millimeters of aluminum equivalent)
70 and below	70 and below	1.5
Above 70	71	2.1
	80	2.3
	90	2.5
	100	2.7

(3) If two or more X-ray tubes are controlled by one X-ray exposure switch or button, the tube or tubes in operation shall be clearly marked before an exposure, on both the X-ray control panel and near or on the selected tube housing assembly.

(4) The tube housing assembly supports shall be adjusted so that the tube housing assembly remains stable and does not drift during an exposure unless the tube housing movement during exposure is a designed function of the X-ray system. The X-ray system and/or tube housing assembly shall not be hand-held during exposure.

(5) Each X-ray control shall have a dead-man switch or button.

(6) Technique indicators shall be set as follows:

(a) All exposure technique factors shall be set on the control panel before the exposure begins, except when automatic exposure controls are used. When automatic exposure controls are used, any preselected settings for each exposure shall be indicated.

(b) On equipment having fixed technique factors, the requirement in (a) of this subsection may be met by permanent markings or labels.

(7) Linearity shall be measured as follows:

(a) The difference between the ratio of milliroentgens (mR) exposure to milliamper second (mAs) at one milliamper (mA) or mAs setting and the ratio of mR exposure to milliamper second (mAs) at another milliamper (mA) or mAs setting must not exceed 0.1 times the sum of the ratios. This is written as:

$$X1 - X2 \leq 0.10 (X1 + X2)$$

Where X1 and X2 are the ratios (mR/mAs) for each mA or mAs setting.

(b) The measurement shall be performed at any selection of mA or mAs without regard to focal spot size, provided neither focal spot size is less than 0.45 millimeters.

(8) When four exposures are made at identical operating settings, the difference between the maximum exposure (E_{max}) and the minimum exposure (E_{min}) must be less than or equal to ten percent of the average exposure (E). This is written as:

$$(E_{max} - E_{min}) \leq 0.1E$$

(9) The difference between the kVp indicated on an X-ray system and the measured kVp shall not be greater than ten percent of the indicated kVp.

(10) Timers shall be able to:

(a) Stop the exposure at a preset time interval, a preset product of current and time, a preset number of pulses, or a preset radiation exposure to the image receptor; and

(b) Reset automatically to the initial setting or to zero when the exposure is stopped.

(11) X-ray equipment shall not be operated when the timer is set to the zero or off position if either position is provided.

(12) Each X-ray control shall have a visual indicator (such as a light) or audible signal so that the operator knows that X rays are being produced or the exposure is occurring or has ended.

NEW SECTION

WAC 246-225A-070 Special requirements for dental extra-oral radiography. Registrants shall use X-ray systems for extra-oral radiography that meet the following requirements for:

(1) Beam limitation.

(a) X-ray equipment designed for only one image receptor size at a fixed source-to-image-receptor distance (SID) shall be able to limit the size of the beam at the plane of the image receptor to no larger than the image receptor, and to align the center of the X-ray beam with the center of the image receptor to within two percent of the SID. In the case of extra-oral imaging systems where the image receptor can be turned vertically or horizontally, the beam-limiting device must also be able to be turned so that the dimensions of the beam match the image receptor dimensions at the image receptor plane.

(b) Intra-oral radiography systems used to perform cephalometric projections, including trans-cranial exams, must be equipped with a stable means to:

(i) Set the source-to-skin distance;

(ii) Comply with the beam size dimensions in subsection (1)(a) of this section; and

(iii) Center the beam to the image receptor as required in subsection (1)(a) of this section.

(c) General purpose medical X-ray equipment used to perform cephalometric exams must:

(i) Have stepless adjustment of the dimensions of the X-ray beam so that the width and height of the X-ray beam are independently adjustable. The minimum beam size at a SID of 100 centimeters must be equal to or less than 10 by 10 centimeters.

(ii) Have a means for operators to visually set the width and height of the X-ray beam. The misalignment of the edges of the visually set light field with the respective edges of the X-ray beam along either the length or width of the visually set light field must not be more than two percent of the distance from the source to the center of the visually defined light field when the surface upon which it appears is perpendicular (at a 90 degree angle) to the central axis of the X-ray beam.

(iii) Have a way to indicate on the X-ray equipment when the axis of the X-ray beam is perpendicular to the plane of the image receptor and to align the center of the X-ray beam to the center of the image receptor to within two percent of the SID (five percent for equipment manufactured before August 1974). Dental lateral jaw examinations are excluded from this requirement.

(iv) Have a beam-limiting device that shows the X-ray beam size in centimeters or inches at the plane of the image receptor to which the beam-limiting device is adjusted.

(v) Have beam size dimension settings that are able to produce X-ray beam dimensions at the plane of the image receptor to within two percent of the SID when the beam axis is perpendicular to the plane of the image receptor.

(vi) Have SID displayed in inches and/or centimeters.

(2) Source-to-skin distance.

(a) Dental extra-oral radiography systems must have a durable, securely fastened means to limit the source-to-skin distance to not less than 23 centimeters. The requirement may be met when the beam-limiting device provides the required limits.

(b) Dental extra-oral radiography systems in which the SID is not fixed must have a device or reference that will indicate the actual SID distance to within two percent of the indicated SID.

(3) Viewing device.

Dental extra-oral radiography installations must provide a viewing device (mirror or glass window or video designed to reduce exposure) so that operators of the X-ray equipment may observe the patient during the exposure without being exposed to the primary beam or stray radiation.

(4) Scattered radiation suppressing grids.

When using scattered radiation suppressing grids, the grids shall be:

(a) Clearly labeled with the SID for which the grids are designed to be used; and

(b) Used at the proper SID.

NEW SECTION

WAC 246-225A-080 Special requirements for dental intra-oral radiography. (1) Registrants using an X-ray system designed for use with an intra-oral image receptor shall use equipment that:

(a) Limits the source-to-skin distance to not less than 18 centimeters;

(b) Limits the X-ray beam so that the beam diameter at the minimum SSD is no greater than 7 centimeters in diameter;

(c) Has an open-ended position-indicating device; and

(d) Has shielding included in the beam-limiting device or position-indicating device equivalent to that required for the diagnostic source assembly under WAC 246-225A-060(1).

(2) After January 1, 2009, registrants shall not use diagnostic dental X-ray systems with a fixed, nominal kilovolts peak of less than 55.

NEW SECTION

WAC 246-225A-090 X-ray image processing requirements. Standards in this section are designed to assure that optimal X-ray image quality and diagnostic information are produced so that fewer retakes are needed, and associated patient and operator exposure are minimal.

(1) When performing manual film processing, also known as hand tank processing, registrants or an operator working under the registrant's direction shall:

(a) Use appropriate chemicals for manual film processing as indicated in chemical and film manufacturer's labels and recommendations.

(b) Mix chemicals in accordance with the chemical manufacturer's recommendations.

(c) Periodically add film developer/fixer replenisher based on the recommendations of the chemical or film manufacturer. Solution may be removed from the tank to permit the addition of an adequate volume of replenisher.

(d) Completely replace all manual processing chemicals at least every two months, or follow the manufacturer's recommendations for periodic chemistry replenishment and maintenance, whichever is shorter.

(e) Post and keep the most recent twelve months of a log that shows when each chemistry change was done and by whom for department inspection.

(f) Process film to achieve the best image quality by either:

(i) Following the film manufacturer's published temperature and time recommendations for X-ray film development; or

(ii) Developing film according to the temperature-time chart in (g) of this subsection.

(g) For standard developer solution, follow the X-ray film developing time specified for the appropriate developer solution temperature in Table 1 of this section:

Table 1

THERMOMETER READINGS (DEGREES)		MINIMUM DEVELOPING TIMES (MINUTES)
C	F	
27	80	2
	79	2
	78	2 1/2
	77	2 1/2
24	76	3
	75	3
	74	3 1/2
	73	3 1/2
22	72	4
	71	4

	THERMOMETER READINGS (DEGREES)	MINIMUM DEVELOPING TIMES (MINUTES)
	70	4 1/2
	69	4 1/2
20	68	5
	67	5 1/2
	66	5 1/2
	65	6
18	64	6 1/2
	63	7
	62	8
	61	8 1/2
16	60	9 1/2

(h) Use X-ray film developing devices that give:

(i) The actual temperature of the developer solution;

(ii) The developing time in minutes and seconds; and

(iii) An audible or visible signal when developing is complete.

(2) When performing automatic film processing, registrants or an operator working under the registrant's direction shall:

(a) Set up and maintain automatic film processors so that X-ray image density and contrast are optimal;

(b) Follow the film manufacturer's published specifications for time and temperature, and the processor manufacturer's recommendations for type of developer chemistry used. If manufacturer's specifications are not available, the film must be developed using the developer temperatures and immersion times specified in Table 2 of this section:

Table 2

DEVELOPER TEMPERATURE		PROCESSOR DEVELOPER IMMERSION TIME*
°C	°F	Seconds
35	95	20
34.5	94	21
34	93	22
33.5	92	23
33	91	24
32	90	25
31.5	89	26
31	88	27
30.5	87	28
30	86	29
29.5	85	30

*Immersion time only, no cross-over time included.

(c) Replenish the developer chemistry to create optimal X-ray images by:

(i) Replacing all automatic processor chemicals at least every month, or follow the manufacturer's recommendations for periodic chemistry replenishment and maintenance, whichever is shorter.

(ii) Posting and maintaining a log that shows when each chemistry change was performed and by whom. The most recent twelve months of the log shall be kept for department inspection.

(iii) Verifying that the processor delivers an adequate rate of developer replenishment; and

(iv) Verifying that standby replenishment, flood replenishment, or prefixed film processing is done periodically as necessary for facilities with a low X-ray workload.

(3) When developing film, registrants or an operator working under the registrant's direction shall:

(a) Set up darkrooms and daylight film loaders so that film being processed, handled, or stored will be exposed only to light passed through a safelight filter. The filter must be of the type specified by the film manufacturer and must not cause excess fog (evidence of light exposure) on X-ray-exposed film. Fog greater than 0.1 optical density is considered unacceptable.

(b) Use bulbs in the darkroom's safelight of fifteen watts or less.

(c) Mount the safelight in the darkroom at least four feet (1.2 meters) above work areas.

(d) Use daylight loaders in darkened areas or where light is dimmed so that the fog standard in (a) of this subsection is met.

(4) When processing digital images, registrants or an operator working under the registrant's direction shall:

(a) Follow the computed radiography (CR) and direct digital radiography (DR) sensor or detector manufacturer's recommendations to achieve adequate diagnostic image quality for the least possible patient exposure.

(b) Process CR phosphor plates using the longest processing time recommended by the manufacturer of the plate processor.

(5) The department may make X-ray film development and darkroom tests as necessary to determine compliance with this section.

NEW SECTION

WAC 246-225A-110 Image processing quality assurance. Beginning January 1, 2009, registrants making images on film shall comply with the following quality assurance requirements for X-ray image processing:

(1) Conduct an acceptable quality assurance program that includes weekly tests of manual and automatic film processing to include:

(a) Density and contrast on test films; and

(b) Action taken when test film density or contrast falls below 15 percent of initial reference levels.

(2) Keep a written or computer log of all periodic quality assurance testing covered in subsection (1) of this section, including test films, from the proceeding twelve months for inspection by the department.

WSR 08-01-136

PROPOSED RULES

DEPARTMENT OF HEALTH

(Veterinary Board of Governors)

[Filed December 19, 2007, 11:30 a.m.]

Original Notice.

Exempt from preproposal statement of inquiry under RCW 34.05.310(4).

Title of Rule and Other Identifying Information: WAC 246-935-990 Veterinary technician fees and renewal cycle.

Hearing Location(s): Department of Health, 20435 72nd South, Second Floor, Conference Room One, Kent, WA 98032, on March 3, 2008, at 11:00 a.m.

Date of Intended Adoption: March 3, 2008.

Submit Written Comments to: Judy Haenke, P.O. Box 47868, Olympia, WA 98504-7868, web site <http://www3.doh.wa.gov/policyreview/>, fax (360) 586-4359, by February 25, 2008.

Assistance for Persons with Disabilities: Contact Judy Haenke by February 25, 2008, TTY (800) 833-6388 or 711.

Purpose of the Proposal and Its Anticipated Effects, Including Any Changes in Existing Rules: HB 1331 changed the credential level of veterinary technicians from registration to licensure in law. Amendments to WAC 246-935-990 as proposed will change the references from "registrations" and "registration" to "licenses" or "license" when referring to veterinary technician fees and renewal cycle. The proposed amendments will not change the fees charged for applications or renewals.

Reasons Supporting Proposal: HB 1331 (chapter 235, Laws of 2007) provides in part for licensure rather than registration of veterinary technicians. The proposed amendments to WAC 246-935-990 will change the references from "registrations" and "registration" to "licenses" or "license" when referring to veterinary technician fees and renewal cycle. The veterinary board of governors is developing rules to implement other provisions of HB 1331 under additional rule filings.

Statutory Authority for Adoption: RCW 43.70.250 and HB 1331 (chapter 235, Laws of 2007).

Statute Being Implemented: RCW 43.70.250 and HB 1331.

Rule is not necessitated by federal law, federal or state court decision.

Name of Proponent: Department of health, veterinary board of governors, governmental.

Name of Agency Personnel Responsible for Drafting, Implementation and Enforcement: Judy Haenke, P.O. Box 47868, Olympia, WA 98504-7868, (360) 236-4947.

No small business economic impact statement has been prepared under chapter 19.85 RCW. The rule is exempt from a small business economic impact statement under RCW 19.85.025, which does not apply to rules adopted under RCW 34.05.310(4).

A cost-benefit analysis is not required under RCW 34.05.328. The rule is exempt from the cost-benefit analysis requirements under RCW 34.05.328 (5)(b)(iii).

December 19, 2007

M. C. Selecky
Secretary

AMENDATORY SECTION (Amending WSR 05-12-012, filed 5/20/05, effective 7/1/05)

WAC 246-935-990 Veterinary technician fees and renewal cycle. (1) (~~Registrations~~) Licenses must be renewed every year on the practitioner's birthday as provided in chapter 246-12 WAC, Part 2. The secretary may require payment of renewal fees less than those established in this section if the current level of fees is likely to result in a surplus of funds. Surplus funds are those in excess of the amount necessary to pay for the costs of administering the program and to maintain a reasonable reserve. Notice of any adjustment in the required payment will be provided to practitioners. The adjustment in the required payment shall remain in place for the duration of a renewal cycle to assure practitioners an equal benefit from the adjustment.

(2) The following nonrefundable fees will be charged:

Title of Fee	Fee
State examination (initial/retake)	\$100.00
Initial (registration) <u>license</u>	75.00
Renewal	65.00
Late renewal penalty	50.00
Expired (registration) <u>license</u> reissuance	50.00
Duplicate (registration) <u>license</u>	15.00
Certification of (registration) <u>license</u>	15.00