

WSR 22-22-002

PERMANENT RULES

BELLINGHAM TECHNICAL COLLEGE

[Filed October 20, 2022, 9:27 a.m., effective November 20, 2022]

Effective Date of Rule: Thirty-one days after filing.

Purpose: 2SHB 1751 updates the definition of hazing and requires institutions of higher education to prohibit, in its code of conduct, hazing off campus as well as on campus as modified in chapter 28B.10 RCW.

The new language ensures that Bellingham Technical College is in compliance with recent legislation.

Citation of Rules Affected by this Order: Amending WAC 495B-121-235, 495B-121-245, 495B-121-265, and 495B-121-286.

Statutory Authority for Adoption: Chapters 28B.10, 34.05 RCW; RCW 28B.50.140(13); 20 U.S.C. § 1092(f).

Other Authority: Chapter 28B.10 RCW.

Adopted under notice filed as WSR 22-18-071 on September 2, 2022.

Number of Sections Adopted in Order to Comply with Federal Statute: New 0, Amended 0, Repealed 0; Federal Rules or Standards: New 1, Amended 3, Repealed 0; or Recently Enacted State Statutes: New 0, Amended 0, Repealed 0.

Number of Sections Adopted at the Request of a Nongovernmental Entity: New 0, Amended 0, Repealed 0.

Number of Sections Adopted on the Agency's own Initiative: New 0, Amended 0, Repealed 0.

Number of Sections Adopted in Order to Clarify, Streamline, or Reform Agency Procedures: New 1, Amended 3, Repealed 0.

Number of Sections Adopted using Negotiated Rule Making: New 0, Amended 0, Repealed 0; Pilot Rule Making: New 0, Amended 0, Repealed 0; or Other Alternative Rule Making: New 0, Amended 0, Repealed 0.

Date Adopted: October 20, 2022.

Ronda Laughlin
Executive Assistant to the President

OTS-4049.2

AMENDATORY SECTION (Amending WSR 21-07-085, filed 3/18/21, effective 4/18/21)

WAC 495B-121-235 Statement of jurisdiction. (1) The student conduct code shall apply to ~~((student))~~ conduct by students and student groups that occurs:

(a) On Bellingham Technical College premises and facilities;
(b) At or in connection with college-sponsored activities; or
(c) To off-campus ~~((, and which,))~~ conduct that in the judgment of the college, adversely affects the college community or the pursuit of its objectives.

(2) Jurisdiction extends to, but is not limited to, locations in which students or student groups are engaged in official college activities including, but not limited to, foreign or domestic travel, activities funded by the associated students, athletic events, training internships, cooperative and distance education, online education,

practicums, supervised work experiences or any other college-sanctioned social or club activities.

(3) Students are responsible for their conduct from notification of admission at the college through the actual receipt of a certificate or degree, even though conduct may occur before classes begin or after classes end, as well as during the academic year and during periods between terms of actual enrollment.

(4) These standards shall apply to a student's conduct even if the student withdraws from college while a disciplinary matter is pending. The college has sole discretion, on a case-by-case basis, to determine whether the student conduct code will be applied to conduct by students or student groups that occurs off campus.

(5) The student conduct officer has sole discretion, on a case-by-case basis, to bring a student conduct proceeding under this code for academic dishonesty. Nothing in this code precludes instructors and/or academic divisions or departments from imposing an academic sanction, up to and including a failing grade in an academic course or dismissal from an academic program, in response to academic dishonesty. Policies and procedures governing the imposition of academic sanctions for academic dishonesty can be found in the college's academic integrity policy, the course syllabus, and any applicable program handbook.

[Statutory Authority: Chapter 34.05 RCW; and RCW 28B.50.140(13); 20 U.S.C. § 1092(f); Title IX of the Education Amendments of 1972, 20 U.S.C. § 1681 et seq.; RCW 28B.50.130. WSR 21-07-085, amended and recodified as § 495B-121-235, filed 3/18/21, effective 4/18/21. Statutory Authority: RCW 28B.50.130. WSR 16-08-029, § 495B-121-060, filed 3/30/16, effective 4/30/16.]

AMENDATORY SECTION (Amending WSR 21-07-085, filed 3/18/21, effective 4/18/21)

WAC 495B-121-245 Definitions. The following definitions shall apply for the purpose of this student conduct code.

(1) "Board" means the board of trustees of Bellingham Technical College.

(2) "College" means Bellingham Technical College.

(3) "Student conduct officer" is a Bellingham Technical College employee designated by the president to be responsible for implementing and enforcing the student conduct code. The president or vice president of student services is authorized to reassign any and all of the student conduct officer's duties or responsibilities as set forth in this chapter as may be reasonably necessary.

(4) "Student group" for purposes of this code is a student organization or living group including, but not limited to, student clubs and organizations, members of a class or student cohort, and student performance groups.

(5) "Conduct review officer" is the vice president of student services or other college administrator designated by the president to be responsible for receiving and for reviewing or referring appeals of student disciplinary actions in accordance with the procedures of this code. The president is authorized to reassign any and all of the conduct review officer's duties or responsibilities as set forth in this chapter as may be reasonably necessary.

~~((5))~~ (6) "The president" is the president of Bellingham Technical College. The president is authorized to:

(a) Delegate any of their responsibilities as set forth in this chapter as may be reasonably necessary; and

(b) Reassign any and all duties and responsibilities as set forth in this chapter as may be reasonably necessary.

~~((6))~~ (7) "Disciplinary action" is the process by which the student conduct officer imposes discipline against a student for a violation of the student conduct code.

~~((7))~~ (8) "Disciplinary appeal" is the process by which an aggrieved student can appeal the discipline imposed by the student conduct officer. Disciplinary appeals from a suspension in excess of ten instructional days or an expulsion are heard by the student conduct committee. Appeals of all other appealable disciplinary action shall be reviewed through brief adjudicative proceedings.

~~((8))~~ (9) "Respondent" is the student against whom disciplinary action is initiated.

~~((9))~~ (10) "Service" is the process by which a document is officially delivered to a party. Unless otherwise provided, service upon a party shall be accomplished by:

(a) Hand delivery of the document to the party; or

(b) By sending the document by email and by certified mail, or first-class mail, to the party's last known address.

Service is deemed complete upon hand delivery of the document or upon the date the document is emailed and deposited in the mail.

~~((10))~~ (11) "Filing" is the process by which a document is officially delivered to a college official responsible for facilitating a disciplinary review. Unless otherwise provided, filing shall be accomplished by:

(a) Hand delivery of the document to the specified college official or college official's assistant; or

(b) By sending the document by email and first-class mail to the specified college official's office and college email address.

Papers required to be filed shall be deemed filed upon actual receipt during office hours at the office of the specified college official.

~~((11))~~ (12) "College premises" includes all campuses of Bellingham Technical College, wherever located, and includes all land, buildings, facilities, vehicles, equipment, and other property owned, used, or controlled by the college.

~~((12))~~ (13) "Student" includes all persons taking courses at or through the college, whether on a full-time or part-time basis, and whether such courses are credit courses, noncredit courses, online courses, or otherwise. Persons who withdraw after allegedly violating the code, who are not officially enrolled for a particular term but who have a continuing relationship with the college, and persons who have been notified of their acceptance for admission are considered "students" for purposes of this chapter.

~~((13))~~ (14) "Day" means a calendar day, except when a "business day" is specified. "Business day" means a weekday, excluding weekends and college holidays.

~~((14))~~ (15) A "complainant" is an alleged victim of sexual misconduct.

~~((15))~~ (16) "Sexual misconduct" has the meaning ascribed to this term in WAC 495B-121-265(13).

[Statutory Authority: Chapter 34.05 RCW; and RCW 28B.50.140(13); 20 U.S.C. § 1092(f); Title IX of the Education Amendments of 1972, 20 U.S.C. § 1681 et seq.; RCW 28B.50.130. WSR 21-07-085, amended and re-codified as § 495B-121-245, filed 3/18/21, effective 4/18/21. Statutory Authority: RCW 28B.50.130. WSR 16-08-029, § 495B-121-010, filed 3/30/16, effective 4/30/16.]

AMENDATORY SECTION (Amending WSR 21-07-085, filed 3/18/21, effective 4/18/21)

WAC 495B-121-265 Prohibited student conduct. The college may impose disciplinary sanctions against a student or student group who commits, attempts to commit, aids, abets, incites, encourages, or assists another person to commit, an act(s) of misconduct, which include, but are not limited to, any of the following:

- (1) Academic dishonesty. Any act of academic dishonesty including, but not limited to, cheating, plagiarism, and fabrication.
 - (a) Cheating includes any attempt to give or obtain unauthorized assistance relating to the completion of an academic assignment.
 - (b) Plagiarism includes taking and using as one's own, without proper attribution, the ideas, writings, or work of another person in completing an academic assignment. Prohibited conduct may also include the unauthorized submission for credit of academic work that has been submitted for credit in another course.
 - (c) Fabrication includes falsifying data, information, or citations in completing an academic assignment and also includes providing false or deceptive information to an instructor concerning the completion of an assignment.
 - (d) Academic consequences for academic dishonesty or abetting in academic dishonesty may be imposed at the discretion of a faculty member up to and including a failing grade for the course or dismissal from an academic program. Policies and procedures governing the imposition of academic sanctions for academic dishonesty can be found in the college's academic integrity policy, the course syllabus, and any applicable program handbook. Incidents of academic dishonesty may also be referred to the student conduct officer for disciplinary action consistent with this chapter in addition to the academic consequences identified above.
- (2) Other dishonesty. Any other acts of dishonesty. Such acts include, but are not limited to:
 - (a) Forgery, alteration, submission of falsified documents or misuse of any college document, record, or instrument of identification;
 - (b) Tampering with an election by or for college students; or
 - (c) Furnishing false information, or failing to furnish correct information, in response to the request or requirement of a college officer or employee.
- (3) Obstruction or disruptive conduct. Conduct, not otherwise protected by law, that interferes with, impedes, or otherwise unreasonably hinders:
 - (a) Any instruction, research, administration, disciplinary proceeding, or other college activities, including the obstruction of the free flow of pedestrian or vehicular movement on campus property or at a college activity; or

(b) Any activity that is authorized to occur on college property, whether or not actually conducted or sponsored by the college.

(4) Assault, intimidation, harassment. Unwanted touching, physical abuse, verbal abuse, threat(s), intimidation, harassment, bullying, or other conduct which harms, threatens, or is reasonably perceived as threatening the health or safety of another person or another person's property. For purposes of this code, "bullying" is defined as repeated or aggressive unwanted behavior, not otherwise protected by law, that intentionally humiliates, harms, or intimidates the victim.

(5) Cyber misconduct. Cyberstalking, cyberbullying or online harassment. Use of electronic communications including, but not limited to, electronic mail, instant messaging, electronic bulletin boards, and social media sites, to harass, abuse, bully or engage in other conduct which harms, threatens, or is reasonably perceived as threatening the health or safety of another person. Prohibited activities include, but are not limited to, unauthorized monitoring of another's email communications directly or through spyware, sending threatening emails, disrupting electronic communications with spam or by sending a computer virus, sending false messages to third parties using another's email identity, nonconsensual recording of sexual activity, and nonconsensual distribution of a recording of sexual activity.

(6) Property violation. Damage to, misappropriation of, unauthorized use or possession of, vandalism, or other nonaccidental damaging or destruction of college property or the property of another person. Property for purposes of this subsection includes computer passwords, access codes, identification cards, personal financial account numbers, other confidential personal information, intellectual property, and college trademarks.

(7) Failure to comply with directive. Failure to comply with the direction of a college officer or employee who is acting in the legitimate performance of their duties, including failure to properly identify oneself to such person when requested to do so.

(8) Weapons. Possession, holding, wearing, transporting, storage or presence of any firearm, dagger, sword, knife or other cutting or stabbing instrument, club, explosive devices, or any other weapon apparently capable of producing bodily harm is prohibited on the college campus, subject to the following exceptions:

(a) Commissioned law enforcement personnel or legally authorized military personnel while in performance of their duties;

(b) A student with a valid concealed weapons permit may store a pistol in their vehicle parked on campus in accordance with RCW 9.41.050 (2) or (3), provided the vehicle is locked and the weapon is concealed from view;

(c) The president may grant permission to bring a weapon on campus upon a determination that the weapon is reasonably related to a legitimate pedagogical purpose. Such permission shall be in writing and shall be subject to such terms or conditions incorporated in the written permission; or

(d) This policy does not apply to the possession and/or use of disabling chemical sprays when possessed and/or used for self-defense.

(9) Hazing. (~~Hazing includes, but is not limited to, any initiation into a student organization or any pastime or amusement engaged in with respect to such an organization that causes, or is likely to cause, bodily danger or physical harm, or serious mental or emotional harm, to any student.~~)

(a) Hazing is any act committed as part of:

(i) A person's recruitment, initiation, pledging, admission into, or affiliation with a student group; or

(ii) Any pastime or amusement engaged in with respect to such a student group; and

(iii) That causes, or is likely to cause, bodily danger or physical harm, or serious psychological or emotional harm, to any student.

(b) Examples of hazing include, but are not limited to:

(i) Causing, directing, coercing, or forcing a person to consume any food, liquid, alcohol, drug, or other substance which subjects the person to risk of such harm;

(ii) Humiliation by ritual act;

(iii) Striking another person with an object or body part;

(iv) Causing someone to experience excessive fatigue, or physical and/or psychological shock; or

(v) Causing someone to engage in degrading or humiliating games or activities that create a risk of serious psychological, emotional, and/or physical harm.

(c) "Hazing" does not include customary athletic events or other similar contests or competitions.

(d) Consent is not a valid defense against hazing.

(10) Alcohol, drug, and tobacco violations.

(a) Alcohol. The use, possession, delivery, sale, or being observably under the influence of any alcoholic beverage, except as permitted by law and applicable college policies.

(b) Marijuana. The use, possession, delivery, sale, or being observably under the influence of marijuana or the psychoactive compounds found in marijuana intended for human consumption, regardless of form. While state law permits the recreational use of marijuana, federal law prohibits such use on college premises or in connection with college activities.

(c) Drugs. The use, possession, delivery, sale, or being observably under the influence of any legend drug, including anabolic steroids, androgens, or human growth hormones as defined in chapter 69.41 RCW, or any other controlled substance under chapter 69.50 RCW, except as prescribed for a student's use by a licensed practitioner.

(d) Tobacco, electronic cigarettes, and related products. The use of tobacco, electronic cigarettes, and related products in any building owned, leased, or operated by the college or in any location where such use is prohibited, including (~~twenty-five~~) 25 feet from entrances, exits, windows that open, and ventilation intakes of any building owned, leased, or operated by the college, except in designated areas. The use of tobacco, electronic cigarettes, and related products on the college campus is restricted to designated smoking areas. "Related products" include, but are not limited to, cigarettes, cigars, pipes, bidi, clove cigarettes, waterpipes, hookahs, chewing tobacco, personal vaporizers, vape pens, electronic nicotine delivery systems, and snuff.

(11) Lewd conduct. Conduct which is lewd or obscene that is not otherwise protected under the law.

(12) Discriminatory conduct. Conduct which harms or adversely affects any member of the college community because of their race; color; national origin; sensory, mental, or physical disability; use of a service animal; gender, including pregnancy; marital status; age; religion; creed; sexual orientation; gender identity; veteran's status; or any other legally protected classification.

(13) Sexual misconduct. The term "sexual misconduct" includes sexual harassment, sexual intimidation, and sexual violence. Sexual

harassment prohibited by Title IX is defined in the supplemental procedures to this code. See WAC 495B-121-355 (supplemental Title IX student conduct procedures).

(a) Sexual harassment. The term "sexual harassment" means unwelcome sexual or gender-based conduct, including unwelcome sexual advances, requests for sexual favors, quid pro quo harassment, and other verbal, nonverbal, or physical conduct of a sexual or a gendered nature that is sufficiently severe, persistent, or pervasive as to:

(i) Deny or limit the ability of a student to participate in or benefit from the college's educational programs;

(ii) Alter the terms or conditions of employment for a college employee(s); and/or

(iii) Create an intimidating, hostile, or offensive environment for other campus community members.

(b) Sexual intimidation. The term "sexual intimidation" incorporates the definition of "sexual harassment" and means threatening or emotionally distressing conduct based on sex including, but not limited to, nonconsensual recording of sexual activity or the distribution of such recording.

(c) Sexual violence. "Sexual violence" is a type of discrimination and harassment. Nonconsensual sexual intercourse, nonconsensual sexual contact, domestic violence, dating violence, and stalking are all types of sexual violence.

(i) Nonconsensual sexual intercourse. Any actual or attempted sexual intercourse (anal, oral, or vaginal), however slight, with any object or body part, by a person upon another person, that is without consent and/or by force. Sexual intercourse includes anal or vaginal penetration by a penis, tongue, finger, or object, or oral copulation by mouth to genital contact or genital to mouth contact.

(ii) Nonconsensual sexual contact. Any actual or attempted sexual touching, however slight, with any body part or object, by a person upon another person that is without consent and/or by force. Sexual touching includes any bodily contact with the breasts, groin, mouth, or other bodily orifice of another individual, or any bodily contact in a sexual manner.

(iii) Incest. Sexual intercourse or sexual contact with a person known to be related to them, either legitimately or illegitimately, as an ancestor, descendant, brother, or sister of either wholly or half related. Descendant includes stepchildren and adopted children under the age of (~~eighteen~~) 18.

(iv) Statutory rape. Consensual intercourse between a person who is (~~eighteen~~) 18 years of age or older, and a person who is under the age of (~~sixteen~~) 16.

(v) Domestic violence. Physical violence, bodily injury, assault, the infliction of fear of imminent physical harm, sexual assault, or stalking committed by a person with whom the victim shares a child in common, by a person who is cohabitating with or has cohabitated with the victim as a spouse, by a person similarly situated to a spouse of the victim under domestic or family violence laws of the state of Washington, or by any other person against an adult or youth victim who is protected from that person's acts under the domestic or family violence laws of the state of Washington, RCW 26.50.010.

(vi) Dating violence. Physical violence, bodily injury, assault, the infliction of fear of imminent physical harm, sexual assault, or stalking committed by a person:

(A) Who is or has been in a social relationship of a romantic or intimate nature with the victim; and

(B) Where the existence of such a relationship shall be determined based on a consideration of the following factors:

(I) The length of the relationship;

(II) The type of relationship; and

(III) The frequency of interaction between the persons involved in the relationship.

(vii) Stalking. Engaging in a course of conduct directed at a specific person that would cause a reasonable person to:

(A) Fear for their safety or the safety of others; or

(B) Suffer substantial emotional distress.

(d) For the purposes of this code, "consent" means knowing, voluntary, and clear permission by word or action, to engage in mutually agreed upon sexual activity. Each party has the responsibility to make certain that the other has consented before engaging in the activity. For consent to be valid, there must be at the time of the act of sexual intercourse or sexual contact actual words or conduct indicating freely given agreement to have sexual intercourse or sexual contact.

A person cannot consent if they are unable to understand what is happening or are disoriented, helpless, asleep, or unconscious for any reason, including due to alcohol or other drugs. An individual who engages in sexual activity when the individual knows, or should know, that the other person is physically or mentally incapacitated has engaged in nonconsensual conduct.

Intoxication is not a defense against allegations that an individual has engaged in nonconsensual sexual conduct.

(14) Harassment. Unwelcome conduct, including verbal, nonverbal, or physical conduct, that is directed at a person because of such person's protected status and that is sufficiently serious as to deny or limit, and that does deny or limit, the ability of a student to participate in or benefit from the college's educational program, that changes the terms or conditions of employment for a college employee, or that creates an intimidating, hostile, or offensive environment for other campus community members. Protected status includes a person's race; color; national origin; sensory, mental, or physical disability; use of a service animal; gender, including pregnancy; marital status; age; religion; creed; sexual orientation; gender identity; veteran's status, or any other legally protected classification. See "sexual misconduct" for the definition of "sexual harassment." Harassing conduct may include, but is not limited to, physical conduct, verbal, written, social media and electronic communications.

(15) Retaliation. Harming, threatening, intimidating, coercing, or taking adverse action of any kind against a person because such person reported an alleged violation of this code or college policy, provided information about an alleged violation, or participated as a witness or in any other capacity in a college investigation or disciplinary proceeding.

(16) Misuse of electronic resources. Theft or misuse of computer time or other electronic information resources of the college. Such misuse includes, but is not limited to:

(a) Unauthorized use of such resources or opening of a file, message, or other item;

(b) Unauthorized duplication, transfer, or distribution of a computer program, file, message, or other item;

(c) Unauthorized use or distribution of someone else's password or other identification;

(d) Use of such time or resources to interfere with someone else's work;

(e) Use of such time or resources to send, display, or print an obscene or abusive message, text, or image;

(f) Use of such time or resources to interfere with normal operation of the college's computing system or other electronic information resources;

(g) Use of such time or resources in violation of applicable copyright or other law;

(h) Adding to or otherwise altering the infrastructure of the college's electronic information resources without authorization; or

(i) Failure to comply with the college's electronic use policy.

(17) Unauthorized access. Unauthorized possession, duplication, or other use of a key, keycard, or other restricted means of access to college property, or unauthorized entry onto or into college property.

(18) Procedural interference. Abuse or misuse of any of the procedures relating to student complaints or misconduct including, but not limited to:

(a) Disruption or interference with the orderly conduct of a proceeding;

(b) Interfering with someone else's proper participation in a proceeding;

(c) Destroying or altering potential evidence, or attempting to intimidate or otherwise improperly pressure a witness or potential witness; or

(d) Attempting to influence the impartiality of, or harassing or intimidating, a student conduct committee member.

(19) Safety violations. Nonaccidental conduct that interferes with or otherwise compromises any college policy, equipment, or procedure relating to the safety and security of the campus community, including tampering with fire safety equipment, triggering false alarms or other emergency response systems, or operating a motor vehicle on college property in a manner which is reasonably perceived as threatening the health or safety of another person.

(20) Violation of other laws or policies. Violation of any federal, state, or local law, rule, or regulation or other college rules or policies, including college traffic and parking rules.

(21) Ethical violation. The breach of any generally recognized and published code of ethics or standards of professional practice that governs the conduct of a particular profession for which the student is taking a course or is pursuing as an educational goal or major.

In addition to initiating discipline proceedings for violations of the student conduct code, the college may refer any violations of federal, state, or local laws to civil and criminal authorities for disposition. The college shall proceed with student disciplinary proceedings regardless of whether the underlying conduct is subject to civil or criminal prosecution.

[Statutory Authority: Chapter 34.05 RCW; and RCW 28B.50.140(13); 20 U.S.C. § 1092(f); Title IX of the Education Amendments of 1972, 20 U.S.C. § 1681 et seq.; RCW 28B.50.130. WSR 21-07-085, amended and recodified as § 495B-121-265, filed 3/18/21, effective 4/18/21. Statutory Authority: RCW 28B.50.130. WSR 16-08-029, § 495B-121-040, filed 3/30/16, effective 4/30/16.]

NEW SECTION

WAC 495B-121-286 Hazing prohibited—Sanctions. (1) Hazing by a student or a student group is prohibited pursuant to WAC 495B-121-265(9).

(2) No student may conspire to engage in hazing or participate in hazing of another. State law provides that hazing is a criminal offense, punishable as a misdemeanor.

(3) Washington state law provides that:

(a) Any student group that knowingly permits hazing is strictly liable for harm caused to persons or property resulting from hazing. If the organization, association, or student living group is a corporation whether for profit or nonprofit, the individual directors of the corporation may be held individually liable for damages.

(b) Any person who participates in the hazing of another shall forfeit any entitlement to state-funded grants, scholarships, or awards for a period of time determined by the college.

(c) Student groups that knowingly permit hazing to be conducted by its members or by others subject to its direction or control shall be deprived of any official recognition or approval granted by the college.

(d) Student groups found responsible for violating the code of student conduct, college anti-hazing policies, or state or federal laws relating to hazing or offenses related to alcohol, drugs, sexual assault, or physical assault will be disclosed in a public report issued by the college setting forth the name of the student group, the date the investigation began, the date the investigation ended, a finding of responsibility, a description of the incident(s) giving rise to the finding, and the details of the sanction(s) imposed.

[]

WSR 22-22-004
PERMANENT RULES
DEPARTMENT OF

CHILDREN, YOUTH, AND FAMILIES

[Filed October 20, 2022, 9:33 a.m., effective November 20, 2022]

Effective Date of Rule: Thirty-one days after filing.

Purpose: The department of children, youth, and families is repealing chapter 110-720 WAC and amending WAC 110-03-0020 and 110-03-0490 as a result of SHB 2050, which repeals parent pay in Washington state. Parent pay requires families to pay a percentage of their income to support their child's incarceration. Parent pay is a barrier to young people's successful transition out of the juvenile system and toward a second chance. The practice has inequitable racial outcomes, creates debt for families already struggling financially, and is an inefficient source of revenue for the state.

Citation of Rules Affected by this Order: Repealing WAC 110-720-0010, 110-720-0020, 110-720-0030, 110-720-0040 and 110-720-0050; and amending WAC 110-03-0020 and 110-03-0490.

Statutory Authority for Adoption: RCW 13.40.220.

Adopted under notice filed as WSR 22-17-036 on August 10, 2022.

Number of Sections Adopted in Order to Comply with Federal Statute: New 0, Amended 0, Repealed 0; Federal Rules or Standards: New 0, Amended 0, Repealed 0; or Recently Enacted State Statutes: New 0, Amended 0, Repealed 0.

Number of Sections Adopted at the Request of a Nongovernmental Entity: New 0, Amended 0, Repealed 0.

Number of Sections Adopted on the Agency's own Initiative: New 0, Amended 0, Repealed 0.

Number of Sections Adopted in Order to Clarify, Streamline, or Reform Agency Procedures: New 0, Amended 2, Repealed 5.

Number of Sections Adopted using Negotiated Rule Making: New 0, Amended 0, Repealed 0; Pilot Rule Making: New 0, Amended 0, Repealed 0; or Other Alternative Rule Making: New 0, Amended 0, Repealed 0.

Date Adopted: October 20, 2022.

Brenda Villarreal
Rules Coordinator

OTS-3840.1

AMENDATORY SECTION (Amending WSR 20-02-031, filed 12/19/19, effective 1/19/20)

WAC 110-03-0020 Definitions. The following definitions apply to this chapter:

"Adjudicative proceeding" means a proceeding in which an opportunity for a hearing occurs before an administrative law judge (ALJ) concerning an administrative appeal of a DCYF action. Hearings and prehearing conferences are elements of adjudicative proceedings. An adjudicative proceeding may take place before the office of administrative hearings (OAH) and may also encompass review proceedings before a DCYF board of appeals (BOA) review judge.

"Administrative law judge" or "ALJ" means an impartial decision-maker who is an attorney and presides over an adjudicative proceeding resulting in an initial order, or resulting in a final order if no appeal of the initial order is properly made or if no further agency appeal is available.

"Adverse action" or "DCYF action" or "department action" means licensing, the enforcement of a statute, the application of an agency rule or order, the imposition of sanctions, or the granting or withholding of benefits.

"Board of appeals" or "BOA" means the DCYF board of appeals, the entity to which an initial order of an ALJ may be appealed and considered by a review judge.

"Business days" means all days except for Saturdays, Sundays, federal legal holidays, and state legal holidays listed in RCW 1.16.050(1).

"Business hours" means 8:00 a.m. to 5:00 p.m. Monday through Friday, except state legal holidays.

"Calendar days" means all days including Saturdays, Sundays, federal legal holidays, and state legal holidays as listed in RCW 1.16.050(1).

"Case" means the entire adjudicative proceeding following the filing of a request for hearing with OAH.

"Continuance" means a change to a later date or time of a pre-hearing conference, hearing, or deadline for other action.

"DCYF" or "department" means the department of children, youth, and families.

"DCYF" or "department representative" means an employee of the department, an assistant attorney general, or special assistant attorney general authorized to represent DCYF in an administrative hearing.

"Documents" means papers, letters, writings, or other printed or written items.

"Ex parte contact" means a written or oral communication with an ALJ or review judge about something related to the hearing when all other parties are not present, as provided in RCW 34.05.455. Procedural questions are not considered an ex parte contact. Examples of procedural questions include clarifying the hearing date, time, or location or asking for directions to the hearing location.

"File" means delivering documents to OAH or the BOA at the location designated in this chapter or in a notice or order received from OAH or the BOA. The date of filing is the date documents are actually received during office hours by OAH or the BOA.

(a) Filing may be by:

(i) Personal service (hand delivery);

(ii) First class, registered, or certified mail;

(iii) Fax transmission, if the party also mails a copy of the document the same day;

(iv) Commercial delivery service; or

(v) Legal messenger service.

(b) A party cannot file documents by email, unless agreed in advance by OAH or BOA.

"Final order" means an order that is the final DCYF decision. An ALJ's initial order becomes a final order if the ALJ's initial order is not appealed to the BOA. If an ALJ's initial order is appealed to the BOA, the review judge's order is DCYF's final order. However, in the case of administrative proceedings related to juvenile parole revocation(~~(, findings of financial responsibility for reimbursement for the cost of support, treatment, and confinement of a juvenile,))~~) or

subsidy overpayments to child care providers, the ALJ's decision is the final administrative decision.

"Good cause" means a substantial reason or legal justification for an action or for failing to appear, act, or respond to an action required under these rules. An ALJ or review judge may use the provisions of superior court civil rule 60 as a guide to determine what may be considered good cause.

"Hearing" means a meeting held before OAH or a review judge that gives an aggrieved party an opportunity to be heard, for the purpose of deciding issues of fact or law, in a dispute resulting from an appealable action taken against the party by DCYF.

"Initial order" is a decision made by an ALJ that may be reviewed by a review judge at any party's request.

"Judicial review" means a superior court's review of a final order.

"Limited-English-proficient person" or "LEP" means a person with limited ability to read, write, or speak English well enough to understand and communicate effectively.

"OAH" means the office of administrative hearings. This is a separate agency and not part of DCYF.

"Party" means DCYF or a person or entity named in a department action, or to whom a department action is directed.

"Prehearing conference" means a meeting scheduled and conducted by an ALJ in preparation for a hearing.

"Program" means a DCYF organizational unit and the services that it provides, including services provided by DCYF staff and through contracts with providers. Organizational units include, but are not limited to, DCYF offices and divisions.

"Reconsideration" means reexamination of a final order on request of a party because the party believes a mistake was made.

"Record" means the official documentation of the hearing process. The record includes recordings or transcripts, admitted exhibits, decisions, briefs, notices, orders, and other filed documents.

"Representative" means the person selected by a party to represent that party in an administrative hearing. A representative may be an attorney or a lay representative who is not an attorney.

"Review" means the act of reevaluating an initial order by examining the record and issuing the DCYF final order as provided by RCW 34.05.464.

"Review judge" or "BOA review judge" means an attorney designated by the DCYF board of appeals to act as the reviewing officer and who is authorized to review ALJ initial orders and to prepare and enter the final order.

"Rule" means a state agency regulation found in the Washington Administrative Code (WAC).

"Serve" or "service" means a procedure by which notice of legal action is given to a party.

(a) Unless otherwise stated in law or rule, a party may serve another party by one of the following methods:

(i) Personal service (hand delivery);
(ii) First class, registered, or certified mail;
(iii) Fax, if the party also mails a copy of the document the same day;

(iv) Commercial delivery service;

(v) Legal messenger service; or

(vi) By any other method authorized by chapter 10-08 WAC.

(b) Service for each method, respectively, is complete when:

- (i) Personal service is made;
 - (ii) Mail is properly stamped, addressed, and deposited in the United States mail;
 - (iii) Fax produces proof of transmission;
 - (iv) A parcel is delivered to a commercial delivery service with charges prepaid; or
 - (v) A parcel is delivered to a legal messenger service with charges prepaid.
 - (c) A party cannot serve documents by email, unless agreed in advance by the receiving party.
 - (d) Notice and orders served by mail by OAH or BOA are served on the date of mailing.
- "Stay" means an order temporarily halting the effective date of a DCYF action.

[Statutory Authority: RCW 34.05.220, 43.216.020, and 43.216.065. WSR 20-02-031, § 110-03-0020, filed 12/19/19, effective 1/19/20.]

AMENDATORY SECTION (Amending WSR 20-02-031, filed 12/19/19, effective 1/19/20)

WAC 110-03-0490 Finality of the initial order. (1) Except as provided in subsection (3) of this section, the ALJ issues an initial order that becomes a final order:

(a) Twenty-one days after the date the initial order is mailed to the parties, when none of the parties has timely requested a review; or

(b) When a request for review is dismissed.

(2) The review judge issues the final order when a party timely requests a review of an initial order.

(3) The ALJ will issue a final order in administrative proceedings concerning juvenile parole revocation(~~(, findings of financial responsibility for reimbursement for the cost of support, treatment, and confinement of a juvenile,)~~) and subsidy overpayments to child care providers.

[Statutory Authority: RCW 34.05.220, 43.216.020, and 43.216.065. WSR 20-02-031, § 110-03-0490, filed 12/19/19, effective 1/19/20.]

OTS-3841.1

REPEALER

The following chapter of the Washington Administrative Code is repealed:

- WAC 110-720-0010 Definitions.
- WAC 110-720-0020 Cost reimbursement schedule and ability to pay.
- WAC 110-720-0030 Modifications.

WAC 110-720-0040 Hearing.

WAC 110-720-0050 Powers of the administrative law judge.

WSR 22-22-011

PERMANENT RULES

DEPARTMENT OF LICENSING

[Filed October 20, 2022, 5:01 p.m., effective November 22, 2022]

Effective Date of Rule: November 22, 2022.

Purpose: The department is increasing fees to cover the cost of administering the geologists program.

Citation of Rules Affected by this Order: Amending WAC 308-15-150 Fees.

Statutory Authority for Adoption: RCW 43.24.086 Fee policy for professions, occupations, and businesses—Determination by rule.

Adopted under notice filed as WSR 22-18-106 on September 7, 2022.

Number of Sections Adopted in Order to Comply with Federal Statute: New 0, Amended 0, Repealed 0; Federal Rules or Standards: New 0, Amended 0, Repealed 0; or Recently Enacted State Statutes: New 0, Amended 0, Repealed 0.

Number of Sections Adopted at the Request of a Nongovernmental Entity: New 0, Amended 0, Repealed 0.

Number of Sections Adopted on the Agency's own Initiative: New 0, Amended 1, Repealed 0.

Number of Sections Adopted in Order to Clarify, Streamline, or Reform Agency Procedures: New 0, Amended 0, Repealed 0.

Number of Sections Adopted using Negotiated Rule Making: New 0, Amended 1, Repealed 0; Pilot Rule Making: New 0, Amended 0, Repealed 0; or Other Alternative Rule Making: New 0, Amended 0, Repealed 0.

Date Adopted: October 20, 2022.

Ellis Starrett
Rules and Policy Manager

OTS-3945.1

AMENDATORY SECTION (Amending WSR 19-22-034, filed 10/31/19, effective 12/1/19)

**WAC 308-15-150 Fees.
Fees.**

Type of Fee	Amount
Application fees - includes initial license	
Application fee for geologist (applying by examination)	((\$100.00)) <u>\$135.00</u>
Application fee for each specialty (applying by examination)	((\$100.00)) <u>\$135.00</u>
Application fee for geologist (applying by reciprocity)	((\$200.00)) <u>\$270.00</u>
Application fee for each specialty (applying by reciprocity)	((\$150.00)) <u>\$203.00</u>
Examination fees	
Administration fee for reexamination	((\$65.00)) <u>\$88.00</u>
Specialty examination (hydrogeologist or engineering geologist examination)	((\$300.00)) <u>\$405.00</u>

Type of Fee	Amount
Renewal fees	
Annual renewal fee for geologist	((\$100.00)) <u>\$135.00</u>
Annual renewal fee for each specialty	((\$85.00)) <u>\$115.00</u>
((Annual renewal for geologist, with)) <u>Late penalty fee (if paid ninety days or more after due date)</u>	((\$200.00)) <u>\$135.00</u>
((Annual renewal for each specialty, with late fee)) <u>Late penalty for each specialty (if paid ninety days or more after due date)</u>	((\$170.00)) <u>\$230.00</u>
Miscellaneous fees	
((Duplicate wall certificate)) <u>Print license fee</u>	((\$25.00)) <u>\$5.00</u>
Certification of license records to other jurisdictions.....	\$45.00
Proctor examination for another jurisdiction.....	\$100.00

In addition to applicable state examination fees, ASBOG may collect, from the applicants, the charges of examination development, examination administration and grading. Terms and conditions for payment of the charges to ASBOG are determined by ASBOG.

[Statutory Authority: RCW 18.220.040, 18.220.050, and 43.24.086. WSR 19-22-034, § 308-15-150, filed 10/31/19, effective 12/1/19. Statutory Authority: RCW 18.220.040 and 43.24.086. WSR 16-12-091, § 308-15-150, filed 5/31/16, effective 7/1/16; WSR 14-11-013, § 308-15-150, filed 5/8/14, effective 7/1/14; WSR 11-08-054, § 308-15-150, filed 4/5/11, effective 7/1/11. Statutory Authority: RCW 18.220.040. WSR 08-12-039, § 308-15-150, filed 5/30/08, effective 7/1/08. Statutory Authority: RCW 18.220.040, 18.220.050. WSR 06-04-022, § 308-15-150, filed 1/23/06, effective 2/23/06; WSR 05-01-174, § 308-15-150, filed 12/21/04, effective 1/21/05. Statutory Authority: Chapter 18.220 RCW. WSR 01-12-022, § 308-15-150, filed 5/25/01, effective 6/25/01.]

WSR 22-22-012

PERMANENT RULES

DEPARTMENT OF LICENSING

[Filed October 20, 2022, 5:03 p.m., effective November 22, 2022]

Effective Date of Rule: November 22, 2022.

Purpose: The department is increasing fees to cover the cost of administering the funerals and cemeteries program.

Citation of Rules Affected by this Order: Amending WAC 308-48-800 Fees.

Statutory Authority for Adoption: RCW 43.24.086 Fee policy for professions, occupations, and businesses—Determination by rule.

Adopted under notice filed as WSR 22-18-105 on September 7, 2022.

Number of Sections Adopted in Order to Comply with Federal Statute: New 0, Amended 0, Repealed 0; Federal Rules or Standards: New 0, Amended 0, Repealed 0; or Recently Enacted State Statutes: New 0, Amended 0, Repealed 0.

Number of Sections Adopted at the Request of a Nongovernmental Entity: New 0, Amended 0, Repealed 0.

Number of Sections Adopted on the Agency's own Initiative: New 0, Amended 1, Repealed 0.

Number of Sections Adopted in Order to Clarify, Streamline, or Reform Agency Procedures: New 0, Amended 0, Repealed 0.

Number of Sections Adopted using Negotiated Rule Making: New 0, Amended 1, Repealed 0; Pilot Rule Making: New 0, Amended 0, Repealed 0; or Other Alternative Rule Making: New 0, Amended 0, Repealed 0.

Date Adopted: October 20, 2022.

Ellis Starrett
Rules and Policy Manager

OTS-3954.1

AMENDATORY SECTION (Amending WSR 20-09-031, filed 4/6/20, effective 5/7/20)

WAC 308-48-800 Fees. (1) Funeral fees.

Title of Fee	Fee
Embalmer:	
State examination application	((\$100.00)) <u>\$135.00</u>
Renewal	((150.00)) <u>203.00</u>
Late renewal fee	((35.00)) <u>47.00</u>
((Duplicate)) <u>License print fee</u>	((25.00)) <u>5.00</u>
Embalmer intern:	
Intern application	((135.00)) <u>182.00</u>
Application for examination	100.00

Title of Fee	Fee
Intern renewal	((100.00)) <u>135.00</u>
Late renewal fee	((35.00)) <u>47.00</u>
((Duplicate)) <u>License print fee</u>	((25.00)) <u>5.00</u>
Funeral director:	
State examination application	((100.00)) <u>135.00</u>
Renewal	((150.00)) <u>203.00</u>
Late renewal fee	((35.00)) <u>47.00</u>
((Duplicate)) <u>License print fee</u>	((25.00)) <u>5.00</u>
Funeral director intern:	
Intern application	((135.00)) <u>182.00</u>
Application for examination	100.00
Intern renewal	((100.00)) <u>135.00</u>
Late renewal fee	((35.00)) <u>47.00</u>
((Duplicate)) <u>License print fee</u>	((25.00)) <u>5.00</u>
Funeral establishment:	
Original application	((400.00)) <u>540.00</u>
Renewal	((325.00)) <u>439.00</u>
Branch license	((350.00)) <u>473.00</u>
Branch renewal	((325.00)) <u>439.00</u>
Preneed application	((250.00)) <u>338.00</u>
Preneed renewal	((225.00)) <u>304.00</u>
<u>License print fee</u>	<u>5.00</u>
Academic intern	No fee
Certificate of removal license:	
Application	((30.00)) <u>41.00</u>
Renewal	((15.00)) <u>25.00</u>
Retired status certificate	No fee

(2) **Cemetery fees.**

Title of Fee	Fee
Certificate of authority:	
Application	((300.00)) <u>405.00</u>
<u>License print fee</u>	<u>5.00</u>

Title of Fee	Fee
Renewal:	((6.20)) <u>8.37</u>
Charge per each interment, entombment and inurnment during preceding calendar year collected at renewal or change of ownership	
Prearrangement sales license Application	((250.00)) <u>338.00</u>
Renewal	((225.00)) <u>304.00</u>
Exemption from prearrangement sales license Application	((70.00)) <u>95.00</u>
Renewal	((35.00)) <u>47.00</u>
Disposition permit for human remains following cremation, alkaline hydrolysis, or natural organic reduction Application	((70.00)) <u>95.00</u>
Renewal	((35.00)) <u>47.00</u>

(3) **Reduction facility fees.**

Title of Fee	Fee
Crematory license application	((210.00)) <u>\$284.00</u>
Alkaline hydrolysis license application	((210.00)) <u>284.00</u>
Natural organic reduction license application	((210.00)) <u>284.00</u>
<u>License print fee</u>	<u>5.00</u>
Renewal:	((8.00)) <u>10.80</u>
Regulatory fee for crematories, alkaline hydrolysis facilities, and natural organic reduction facilities collected at time of renewal per cremation, hydrolysis, or natural organic reduction performed during previous calendar year	
Crematory operator license: Application	((135.00)) <u>182.00</u>
Renewal	((100.00)) <u>135.00</u>
Alkaline hydrolysis operator license: Application	((135.00)) <u>182.00</u>
Renewal	((100.00)) <u>135.00</u>

Title of Fee	Fee
Natural organic reduction facility operator license:	
Application	((135.00)) <u>182.00</u>
Renewal	((100.00)) <u>135.00</u>

[Statutory Authority: RCW 68.05.105 and 18.39.175. WSR 20-09-031, § 308-48-800, filed 4/6/20, effective 5/7/20. Statutory Authority: RCW 68.05.205, 18.39.050, and 43.24.086. WSR 14-24-067, § 308-48-800, filed 11/26/14, effective 1/1/15. Statutory Authority: RCW 18.39.050 and 18.39.175, chapter 34.05 RCW and RCW 43.24.086. WSR 10-24-046, § 308-48-800, filed 11/24/10, effective 1/1/11; WSR 09-17-116, § 308-48-800, filed 8/18/09, effective 9/18/09. Statutory Authority: RCW 18.39.175 and chapter 34.05 RCW. WSR 07-18-030, § 308-48-800, filed 8/28/07, effective 9/28/07; WSR 07-03-027, § 308-48-800, filed 1/5/07, effective 2/5/07. Statutory Authority: RCW 18.39.181 and chapter 34.05 RCW. WSR 05-20-076, § 308-48-800, filed 10/4/05, effective 11/4/05. Statutory Authority: RCW 18.39.050. WSR 03-11-021, § 308-48-800, filed 5/12/03, effective 6/30/03. Statutory Authority: RCW 18.39.181. WSR 99-16-040, § 308-48-800, filed 7/29/99, effective 8/29/99. Statutory Authority: RCW 18.39.175(4). WSR 98-21-056, § 308-48-800, filed 10/19/98, effective 11/19/98; WSR 91-11-023, § 308-48-800, filed 5/7/91, effective 6/7/91; WSR 91-01-006, § 308-48-800, filed 12/6/90, effective 1/6/91. Statutory Authority: RCW 43.24.086. WSR 90-07-024, § 308-48-800, filed 3/14/90, effective 4/14/90; WSR 87-10-028 (Order PM 650), § 308-48-800, filed 5/1/87.]

WSR 22-22-016
PERMANENT RULES
BOARD OF
PILOTAGE COMMISSIONERS

[Filed October 21, 2022, 8:08 a.m., effective November 21, 2022]

Effective Date of Rule: Thirty-one days after filing.

Purpose: To revise the pilot license upgrade programs in both the Puget Sound and Grays Harbor Pilotage Districts to better align with statutory rest rules and changes in vessel traffic. The board seeks to ensure that upgrading pilots are gaining the necessary experience with larger vessels as they progress through their first five years of piloting, while also maintaining best practices in fatigue mitigation and reducing stress on the pilot corps.

Citation of Rules Affected by this Order: Amending WAC 363-116-082.

Statutory Authority for Adoption: Chapter 88.16 RCW, Pilotage Act.

Adopted under notice filed as WSR 22-18-084 on September 6, 2022.

Number of Sections Adopted in Order to Comply with Federal Statute: New 0, Amended 0, Repealed 0; Federal Rules or Standards: New 0, Amended 0, Repealed 0; or Recently Enacted State Statutes: New 0, Amended 0, Repealed 0.

Number of Sections Adopted at the Request of a Nongovernmental Entity: New 0, Amended 0, Repealed 0.

Number of Sections Adopted on the Agency's own Initiative: New 0, Amended 1, Repealed 0.

Number of Sections Adopted in Order to Clarify, Streamline, or Reform Agency Procedures: New 0, Amended 1, Repealed 0.

Number of Sections Adopted using Negotiated Rule Making: New 0, Amended 0, Repealed 0; Pilot Rule Making: New 0, Amended 0, Repealed 0; or Other Alternative Rule Making: New 0, Amended 0, Repealed 0.

Date Adopted: October 20, 2022.

Jaimie C. Bever
Executive Director

OTS-4063.1

AMENDATORY SECTION (Amending WSR 20-12-065, filed 6/1/20, effective 7/2/20)

WAC 363-116-082 Limitations on new pilots. (1) The following limitations and pilot license upgrade requirements shall apply to a newly licensed pilot during ((his/her)) their first five years of active service. For purposes of this section, the term "tank vessel" shall, in addition to tank ships, include any articulated or integrated tug and tank barge combinations, and any tonnage restrictions thereon shall be calculated by including the gross tonnage of the tug and tank barge combined. For purposes of this section, the term "petroleum products" shall include crude oil, refined products, liquefied natural gas, and liquefied petroleum gas. GT (ITC) as used in this section refers to gross tonnages measured in accordance with the re-

quirements of the 1969 International Convention on Tonnage Measurement of Ships.

(2) Puget Sound pilotage district - License limitation periods. Except for trips being made for pilot license upgrades, licenses issued in the Puget Sound pilotage district shall have the following limitations:

License Year	Maximum Size of Tank Vessels Carrying Petroleum Products as Bulk Cargo	Maximum Size of Other Vessels	Waterways
1	Piloting on vessels of any size prohibited	38,000 GT (ITC) except for passenger vessels which may only have a maximum size of 5000 GT (ITC)	Prohibited in the Duwamish Waterway on vessels greater than 3,000 GT
2	32,000 GT (ITC)	48,000 GT (ITC)	No restrictions
3	40,000 GT (ITC)	60,000 GT (ITC)	No restrictions
4	50,000 GT (ITC)	70,000 GT (ITC)	No restrictions
5	65,000 GT (ITC)	95,000 GT (ITC)	No restrictions

(3) Puget Sound pilotage district - Pilot license upgrade requirements. Progressive lifting of tonnage limitations requires a newly licensed pilot to satisfactorily pilot vessels on the trips specified in this section. The trainee evaluation committee shall recommend to the board a series of (~~eight~~) trips to be made by each pilot in the last (~~one hundred twenty~~) 180 days of each year of the license limitation periods specified in subsection (2) of this section. As to these trips, the trainee evaluation committee shall specify the size and type of the vessel; origin and destination, whether the transit is to include a docking, waterway transit or other particular maneuvering requirement, whether any tank vessel trips are to be made while in ballast or loaded and whether the trip shall be taken with training pilots, trainee evaluation committee member pilots or pilots with a specified experience level. To the extent practical, the trips shall be on vessels of at least a size that falls between the upper limit in the expiring license limitation and the upper limit in the upcoming license limitation period. All of these trips shall be complete trips between one port and another port, (~~or~~) between the pilot station and a port, or harbor shifts. The supervising pilots shall complete and submit to the board (~~an evaluation~~) a familiarization form provided by the board for each trip a new pilot performs.

(4) Grays Harbor pilotage district - License limitation periods. Pilots licensed in the Grays Harbor pilotage district shall not pilot vessels in violation of the restrictions set forth in the table below during the indicated license year.

License Year	Maximum Size of Tank Vessels Carrying Petroleum Products as Bulk Cargo	Maximum Size of Other Vessels
1	Piloting on vessels of any size prohibited	32,000 GT (ITC) except that piloting on vessels of any size is prohibited through the Chehalis River Bridge unless vessel is in ballast and does not exceed 25,000 GT (ITC)
2	15,000 GT (ITC)	42,000 GT (ITC)
3	32,000 GT (ITC)	52,000 GT (ITC)
4	42,000 GT (ITC)	62,000 GT (ITC)
5	52,000 GT (ITC)	72,000 GT (ITC)

Notwithstanding subsection (7) of this section, upon determination that a bona fide safety concern may result from no pilot without license restrictions being available within a reasonable time to pilot a vessel requiring pilotage services, the chairperson or acting chairperson of the board, on a single trip basis, may authorize a newly licensed pilot holding a restricted license to provide pilotage services to the vessel, irrespective of the tonnage, service or location of the assigned berth of the vessel.

(5) Grays Harbor pilotage district - Pilot license upgrade requirements - Progressive lifting of tonnage limitations requires a newly licensed pilot to satisfactorily pilot vessels on the trips specified in this section. The trainee evaluation committee shall recommend to the board a series of trips to be made by each pilot in the last 180 days of each year of the license limitation periods specified in subsection (4) of this section. As to these trips, the trainee evaluation committee shall specify the size and type of the vessel; origin and destination, whether the transit is to include a docking, waterway transit or other particular maneuvering requirement, whether any tank vessel trips are to be made while in ballast or loaded and whether the trip shall be taken with training pilots, trainee evaluation committee member pilots or pilots with a specified experience level. To the extent practical, the trips shall be on vessels of at least a size that falls between the upper limit in the expiring license limitation and the upper limit in the upcoming license limitation period. All of these trips shall be complete trips between one port and another port, between the pilot station and a port, or harbor shifts. The supervising pilots shall complete and submit to the board a familiarization form provided by the board for each trip a new pilot performs.

((a) Prior to the expiration of the first license year, a new pilot must make five license upgrade trips. Three of these trips shall be through the Chehalis River Bridge on loaded or partially loaded vessels. The other trips shall be on vessels in excess of 32,000 GT (ITC) and involve docking and passage to or from the sea buoy; and one of these trips shall involve turning the vessel in the waterway.

(b) Prior to the expiration of the second license year, a new pilot must make two license upgrade trips on tank vessels in excess of

~~15,000 GT (ITC) and two trips on other vessels in excess of 42,000 GT (ITC). Two of these trips shall involve docking and passage to or from the sea buoy; and two of these trips shall involve turning the vessel in the waterway. Upon satisfactory completion of the two upgrade trips upon tank vessels and completion of the second license year, the pilot will be authorized to pilot tank vessels in accordance with the limitations specified in subsection (4) of this section. Upon satisfactory completion of the two upgrade trips upon other vessels in excess of 42,000 GT (ITC) and completion of the second license year, the pilot will be authorized to pilot vessels in accordance with the limitations specified in subsection (4) of this section.~~

~~(c) Prior to the expiration of the third license year, a new pilot must make two license upgrade trips on tank vessels in excess of 32,000 GT (ITC) and two trips on other vessels in excess of 52,000 GT (ITC). Two of these trips shall involve docking and passage to or from the sea buoy; and two of these trips shall involve turning the vessel in the waterway.~~

~~(d) Prior to the expiration of the fourth license year, a new pilot must make two license upgrade trips on tank vessels in excess of 42,000 GT (ITC) and two trips on other vessels in excess of 62,000 GT (ITC).~~

~~(e) Prior to the expiration of the fifth license year, a new pilot must make two license upgrade trips on tank vessels in excess of 52,000 GT (ITC) and two trips on other vessels in excess of 72,000 GT (ITC).~~

~~(f)) If vessels are not available in the Grays Harbor pilotage district to allow a pilot to comply with ((a) through (e) of) this subsection in a timely manner, the board may designate substitute trips in the Puget Sound pilotage district as allowed by law and in so doing may specify the size of the vessel and any other characteristics of the trips that the board deems appropriate. Such designation shall be considered a modification of the pilot's state license to authorize the specified trips in the Puget Sound pilotage district.~~

(6) The initial license shall contain the limitations contained above and list the date of commencement and expiration of such periods. If a newly licensed pilot is unable to pilot for ((forty-five)) 45 days or more in any one of the five years((, he/she shall notify the board and request a revised schedule of limitations)) the trainee evaluation committee may put a hold on the upgrade program. Upon the newly licensed pilot's return to the program, the trainee evaluation committee may prescribe an extension.

(7) Except as provided in subsection (4) of this section, no pilot shall be dispatched to, or accept an assignment on, any vessel which exceeds the limitations of ((his/her)) their license. On vessels in which there is more than one pilot assigned, the license limitations shall apply only to the pilot in charge.

(8) All limitations on a pilot's license shall be lifted at the beginning of the sixth year of piloting provided ((he/she has)) they have submitted to the board a statement attesting to the fact that ((he/she)) the pilot has completed all the required license upgrade trips and the vessel simulator courses.

(9) Whenever the governor issues a proclamation declaring a state of emergency, the board may determine whether there is a threat to trainees, pilots, vessel crews, or members of the public. Notwithstanding the other provisions of this chapter, the board, at its discretion, may suspend or adjust the pilot training program during the pendency of a state of emergency lawfully declared by the governor.

[Statutory Authority: Chapter 88.16 RCW. WSR 20-12-065, § 363-116-082, filed 6/1/20, effective 7/2/20; WSR 19-06-007, § 363-116-082, filed 2/22/19, effective 3/25/19; WSR 15-04-136, § 363-116-082, filed 2/4/15, effective 3/7/15. Statutory Authority: Chapter 88.16 RCW and 2008 c 128. WSR 08-15-119, § 363-116-082, filed 7/21/08, effective 8/21/08. Statutory Authority: RCW 88.16.105 and 88.16.035. WSR 07-17-148, § 363-116-082, filed 8/21/07, effective 9/21/07. Statutory Authority: Chapter 88.16 RCW and 2005 c 26. WSR 05-18-021, § 363-116-082, filed 8/29/05, effective 10/1/05. Statutory Authority: RCW 88.16.105 and 88.16.035. WSR 05-04-028, § 363-116-082, filed 1/26/05, effective 2/26/05. Statutory Authority: RCW 88.16.105. WSR 99-08-003, § 363-116-082, filed 3/25/99, effective 4/25/99; WSR 97-14-032, § 363-116-082, filed 6/25/97, effective 7/26/97. WSR 97-08-042, recodified as § 363-116-082, filed 3/28/97, effective 3/28/97. Statutory Authority: RCW 88.16.035 and 88.16.105. WSR 93-09-016, § 296-116-082, filed 4/14/93, effective 5/15/93. Statutory Authority: RCW 88.16.105. WSR 92-24-056, § 296-116-082, filed 11/30/92, effective 12/31/92; WSR 92-08-051, § 296-116-082, filed 3/26/92, effective 4/26/92; WSR 89-18-063 (Order 89-6, Resolution No. 89-6), § 296-116-082, filed 9/1/89, effective 10/2/89; WSR 89-11-060 (Order 89-5, Resolution No. 89-5), § 296-116-082, filed 5/18/89. Statutory Authority: RCW 88.16.035. WSR 80-03-081 (Order 79-6, Resolution No. 79-6), § 296-116-082, filed 3/4/80.]

WSR 22-22-022

PERMANENT RULES

DEPARTMENT OF LICENSING

[Filed October 21, 2022, 2:48 p.m., effective November 22, 2022]

Effective Date of Rule: November 22, 2022.

Purpose: The department is required to set fees for each professional, occupational, or business licensing program at a sufficient level to defray the costs of administering that program. Many of these programs have not seen an increase in fees for some time, some since as far back as 1990. Current fees are insufficient to sustain these programs. The department is considering fee increases that would go into effect November of 2022.

Citation of Rules Affected by this Order: WAC 36-12-195 License fees, renewals and requirements, 36-13-010 License fees, renewals and requirements, 36-14-110 License fees, renewals and requirements, 308-11-030 Auctioneer fees, 308-14-200 Court reporter fees, 308-17-150 Private investigative agency, private investigator, and armed private investigator fees, 308-18-150 Private security guard company, private security guard, and armed private security guard fees, 308-19-130 Bail bond recovery agent, bail bond agency, branch office and bail bond agent fees, 308-20-210 Fees, 308-22-050 Fees, 308-30-060 Application fees, 308-33-105 Employment agency fees, 308-127-160 Fees, 308-129-110 Seller of travel registration fees, 308-320-050 Registration fees, 308-320-060 Annual renewal dates, forms, and fees, 308-408A-090 Home inspector fees, and 308-420-240 Fees and charges.

Statutory Authority for Adoption: RCW 43.24.086 Fee policy for professions, occupations, and businesses—Determination by rule.

Adopted under notice filed as WSR 22-18-104 on September 7, 2022.

Number of Sections Adopted in Order to Comply with Federal Statute: New 0, Amended 0, Repealed 0; Federal Rules or Standards: New 0, Amended 0, Repealed 0; or Recently Enacted State Statutes: New 0, Amended 0, Repealed 0.

Number of Sections Adopted at the Request of a Nongovernmental Entity: New 0, Amended 0, Repealed 0.

Number of Sections Adopted on the Agency's own Initiative: New 0, Amended 18 [17], Repealed 0.

Number of Sections Adopted in Order to Clarify, Streamline, or Reform Agency Procedures: New 0, Amended 0, Repealed 0.

Number of Sections Adopted using Negotiated Rule Making: New 0, Amended 18 [17], Repealed 0; Pilot Rule Making: New 0, Amended 0, Repealed 0; or Other Alternative Rule Making: New 0, Amended 0, Repealed 0.

Date Adopted: October 21, 2022.

Ellis Starrett
Rules and Policy Manager

OTS-3939.1

AMENDATORY SECTION (Amending WSR 13-21-149, filed 10/23/13, effective 12/1/13)

WAC 36-12-195 License fees, renewals and requirements. (1) The license year is one year from date of issue. License fees are paid annually. Fees shall be as follows:

Manager	-	(\$65.00) \$75.00
Referee	-	(\$65.00) \$75.00
Boxer	-	(\$25.00) \$35.00
Matchmaker	-	(\$65.00) \$75.00
Second	-	(\$25.00) \$35.00
Inspector	-	(\$65.00) \$75.00
Judge	-	(\$65.00) \$75.00
Timekeeper	-	(\$65.00) \$75.00
Announcer	-	(\$65.00) \$75.00
Event physician	-	No charge
Event chiropractor	-	(\$65.00) \$75.00
Promoter	-	(\$500.00) \$540.00

(2) All renewal fees shall be the same fee as each original license fee.

(3) Licensing requirements:

(a) Completed application on form approved by the department.

(b) Completed physical within one year (boxer and referee only).

(c) Federal identification card (boxer only).

(d) One small current photograph, not more than two years old (boxer only).

(e) Payment of license fee.

(f) Certification from an organization approved by the department under RCW 67.08.100(3) and WAC 36-12-196.

(4) Applicants may not participate until all licensing requirements are received and approved by the department of licensing.

[Statutory Authority: RCW 43.24.023, 67.08.015, and 67.08.017. WSR 13-21-149, § 36-12-195, filed 10/23/13, effective 12/1/13. Statutory Authority: RCW 67.08.017, 43.24.086, 67.08.105. WSR 10-08-037, § 36-12-195, filed 4/1/10, effective 5/2/10. Statutory Authority: RCW 67.08.017, 67.08.105, and 43.24.023. WSR 02-20-094, § 36-12-195, filed 10/1/02, effective 1/1/03. Statutory Authority: RCW 67.08.017(1). WSR 01-22-029, § 36-12-195, filed 10/29/01, effective 11/29/01; WSR 00-02-054, § 36-12-195, filed 12/31/99, effective 1/31/00. Statutory Authority: Chapter 67.08 RCW. WSR 97-01-035, § 36-12-195, filed 12/10/96, effective 1/10/97; WSR 91-11-038, § 36-12-195, filed 5/10/91, effective 6/10/91.]

OTS-3940.1

AMENDATORY SECTION (Amending WSR 17-21-118, filed 10/18/17, effective 11/21/17)

WAC 36-13-010 License fees, renewals and requirements. (1) The license year is one year from date of issue. License fees are paid annually. Fees shall be as follows:

Wrestling participant	-	(\$25.00) \$35.00
Inspector	-	(\$65.00) \$75.00
Event physician	-	No charge
Promoter	-	(\$200.00) \$220.00
Theatrical wrestling school	-	(\$500.00) \$540.00

(2) No license fee is required for persons licensed under chapter 36-12 or 36-14 WAC as an inspector, event physician or promoter.

(3) In addition to license requirements found in chapter 67.08 RCW:

(a) Wrestling participants shall submit a small photograph of themselves that is not more than two years old.

(b) Theatrical wrestling schools:

(i) Must provide proof of having an established place of business that offers training in theatrical wrestling.

(ii) Must provide proof of having an active tax registration through the department of revenue.

(iii) Must reapply for licensure when there is a change in the location or change in ownership.

[Statutory Authority: RCW 67.08.330(4), 67.08.017, and 43.24.086. WSR 17-21-118, § 36-13-010, filed 10/18/17, effective 11/21/17. Statutory Authority: RCW 67.08.017, 43.24.023, and 43.24.086. WSR 15-23-055, § 36-13-010, filed 11/12/15, effective 12/13/15. Statutory Authority: RCW 67.08.017, 43.24.086, 67.08.105. WSR 10-08-037, § 36-13-010, filed 4/1/10, effective 5/2/10. Statutory Authority: RCW 67.08.017, 67.08.105, and 43.24.023. WSR 02-20-094, § 36-13-010, filed 10/1/02, effective 1/1/03. Statutory Authority: RCW 67.08.017(1). WSR 00-02-054, § 36-13-010, filed 12/31/99, effective 1/31/00.]

OTS-3941.1

AMENDATORY SECTION (Amending WSR 12-24-045, filed 11/30/12, effective 1/1/13)

WAC 36-14-110 License fees, renewals and requirements. (1) The license year is one year from date of issue. License fees are paid annually. Fees shall be as follows:

Manager	-	(\$65.00) \$75.00
Referee	-	(\$65.00) \$75.00
Kickboxer	-	(\$25.00) \$35.00
Martial arts participant	-	(\$25.00) \$35.00
Amateur mixed martial arts participant	-	(\$25.00) \$35.00
Matchmaker	-	(\$65.00) \$75.00
Second	-	(\$25.00) \$35.00
Inspector	-	(\$65.00) \$75.00
Judge	-	(\$65.00) \$75.00
Timekeeper	-	(\$65.00) \$75.00
Announcer	-	(\$65.00) \$75.00
Event physician	-	No charge
Event chiropractor	-	(\$65.00) \$75.00
Promoter	-	(\$500.00) \$540.00
Training facility	-	(\$500.00) \$540.00
Amateur mixed martial arts sanctioning organization	-	(\$500.00) \$540.00

(2) All renewal fees shall be the same fee as each original license fee.

(3) Licensing requirements:

(a) Completed application on form approved by the department.

(b) Completed physical within one year (kickboxer, martial arts participant, amateur mixed martial arts participant, and referee only).

(c) One small current photograph, not more than two years old (kickboxer, martial arts participant, and amateur mixed martial arts participants only).

(d) Payment of license fee.

(e) Certification from an organization approved by the department under RCW 67.08.100(3).

(f) Training facility: Have an established place of business that offers training in one or more of the mixed martial arts and a current tax registration through the department of revenue.

(g) Amateur mixed martial arts sanctioning organizations:

(i) Have an established place of business that offers training in one or more of the mixed martial arts;

(ii) Have a current tax registration through the department of revenue;

(iii) Have a minimum of three years total combined amateur or professional experience in at least three of the following areas: Referee, promoter, judge, inspector, have an established place of business that offers training in one or more of the mixed martial arts;

(iv) Provide to the department a list of authorized representatives who will be in charge of events or exhibitions. Changes to this list will not be accepted within (~~thirty~~) 30 days prior to an event or exhibition.

(4) Applicants may not participate until all licensing requirements are received and approved by the department of licensing.

[Statutory Authority: RCW 43.24.023, 43.24.086, 67.08.015, 67.08.017, 67.08.105, 67.08.107, and 2012 c 99. WSR 12-24-045, § 36-14-110, filed 11/30/12, effective 1/1/13. Statutory Authority: RCW 67.08.017, 43.24.086, 67.08.105. WSR 10-08-037, § 36-14-110, filed 4/1/10, effective 5/2/10. Statutory Authority: RCW 67.08.017, 67.08.105, and 43.24.023. WSR 02-20-094, § 36-14-110, filed 10/1/02, effective 1/1/03. Statutory Authority: RCW 67.08.017(1). WSR 00-02-054, § 36-14-110, filed 12/31/99, effective 1/31/00.]

OTS-3942.1

AMENDATORY SECTION (Amending WSR 07-16-036, filed 7/23/07, effective 9/1/07)

WAC 308-11-030 Auctioneer fees. The following fees shall be charged by the business and professions division of the department of licensing:

Title of Fee	Fee
Auctioneer:	
Initial application	(\$155.00) <u>\$171.00</u>
Renewal	(155.00) <u>171.00</u>
Late renewal penalty	(100.00) <u>110.00</u>
((Duplicate)) <u>License print fee</u>	(15.00) <u>5.00</u>
Certification	25.00
Auction company:	
Initial application	(255.00) <u>281.00</u>
Renewal	(255.00) <u>281.00</u>
Late renewal penalty	(100.00) <u>110.00</u>
((Duplicate)) <u>License print fee</u>	(15.00) <u>5.00</u>

[Statutory Authority: RCW 18.11.200 and 43.24.086. WSR 07-16-036, § 308-11-030, filed 7/23/07, effective 9/1/07. Statutory Authority: RCW 18.11.060, 43.24.086, 43.24.023. WSR 04-17-074, § 308-11-030, filed 8/13/04, effective 10/1/04. Statutory Authority: RCW 18.11.060, 43.24.086 and 43.135.055. WSR 98-16-061, § 308-11-030, filed 8/3/98, effective 9/3/98. Statutory Authority: RCW 43.24.086. WSR 90-06-052, §

308-11-030, filed 3/2/90, effective 4/2/90; WSR 87-10-028 (Order PM 650), § 308-11-030, filed 5/1/87. Statutory Authority: RCW 18.11.060. WSR 86-21-127 (Order PM 622), § 308-11-030, filed 10/22/86. Statutory Authority: 1983 c 168 § 12. WSR 83-17-031 (Order PL 442), § 308-11-030, filed 8/10/83. Formerly WAC 308-11-001.]

OTS-3944.1

AMENDATORY SECTION (Amending WSR 09-22-051, filed 10/29/09, effective 12/1/09)

WAC 308-14-200 Court reporter fees. The following fees shall be charged by the business and professions division, department of licensing:

Title of Fee	Fee
Certification	
Application	((\$150.00)) \$165.00
Renewal	((125.00)) 138.00
Late renewal penalty	((125.00)) 138.00
Verification	25.00
((Duplicate)) <u>License print fee</u>	((15.00)) 5.00

[Statutory Authority: RCW 43.24.086 and 18.145.050. WSR 09-22-051, § 308-14-200, filed 10/29/09, effective 12/1/09; WSR 07-16-036, § 308-14-200, filed 7/23/07, effective 9/1/07. Statutory Authority: RCW 18.145.050, 43.24.086, 43.24.023. WSR 04-17-073, § 308-14-200, filed 8/13/04, effective 10/1/04. Statutory Authority: RCW 18.145.050, 43.24.086 and 43.135.055. WSR 98-16-060, § 308-14-200, filed 8/3/98, effective 9/3/98. Statutory Authority: Chapter 18.145 RCW and RCW 43.24.086. WSR 90-10-009, § 308-14-200, filed 4/20/90, effective 5/21/90.]

OTS-3946.1

AMENDATORY SECTION (Amending WSR 16-13-003, filed 6/1/16, effective 7/2/16)

WAC 308-17-150 Private investigative agency, private investigator, and armed private investigator fees. Licenses issued to private investigator agencies and private investigators expire one year from the date of issuance and must be renewed each year. The fees are as follows:

Title of Fee	Fee
Private investigative agency/principal fee:	
Application/examination/includes first examination plus current applicable background check fees	((\$600.00)) <u>\$640.00</u>
Principal armed endorsement	((100.00)) <u>110.00</u>
Reexamination	25.00
License renewal	((350.00)) <u>385.00</u>
Late renewal penalty	See below*
Change of principal/includes first examination plus current applicable background check fees	150.00
Private investigator:	
Original license plus current applicable background check fees	((200.00)) <u>220.00</u>
Armed endorsement plus current applicable background check fees	((100.00)) <u>110.00</u>
Transfer fee	25.00
License renewal	((175.00)) <u>193.00</u>
Late renewal ((with)) penalty	((200.00)) <u>35.00</u>
Certified trainer endorsement examination/reexamination	25.00
Certified trainer endorsement renewal	15.00
<u>License print fee</u>	<u>5.00</u>

*Private investigative agency license renewals filed after the license expiration date will be charged the master license service late renewal fee in compliance with RCW 19.02.085.

[Statutory Authority: RCW 18.165.170(1). WSR 16-13-003, § 308-17-150, filed 6/1/16, effective 7/2/16. Statutory Authority: Chapter 18.165 RCW. WSR 06-13-036, § 308-17-150, filed 6/15/06, effective 7/16/06; WSR 04-12-024, § 308-17-150, filed 5/26/04, effective 7/1/04. Statutory Authority: RCW 43.24.086 and chapter 18.165 RCW. WSR 02-11-098, § 308-17-150, filed 5/20/02, effective 10/1/02. Statutory Authority: RCW 18.165.170(1), 43.24.086 and 34.05.482. WSR 97-17-051, § 308-17-150, filed 8/15/97, effective 9/15/97. Statutory Authority: RCW 18.165.170(1). WSR 93-16-060, § 308-17-150, filed 7/29/93, effective 9/1/93. Statutory Authority: RCW 18.165.170. WSR 91-22-111, § 308-17-150, filed 11/6/91, effective 12/7/91.]

OTS-3947.1

AMENDATORY SECTION (Amending WSR 15-22-109, filed 11/4/15, effective 12/5/15)

WAC 308-18-150 Private security guard company, private security guard, and armed private security guard fees. Licenses issued to pri-

vate security guard companies and private security guards expire one year from the date of issuance and must be renewed each year. The fees are as follows:

Title of Fee	Fee
Private security guard company/principal:	
Application/includes first examination plus background check fee	((\$330.00)) <u>\$263.00</u>
Reexamination	25.00
License renewal	((300.00)) <u>237.00</u>
Late renewal ((with)) penalty	((400.00)) <u>110.00</u>
Change of principal/includes first examination plus background check fee	80.00
Principal armed endorsement	10.00
Private security guard:	
Original license plus background check fee	((91.00)) <u>101.00</u>
Armed endorsement	10.00
Transfer fee	25.00
Licensees with inactive licenses are not required to pay late renewal penalty fees.	
License renewal	((85.00)) <u>95.00</u>
License late renewal ((with)) penalty. Late fee is not due if submitting a renewal with a transfer or rehire application.	((90.00)) <u>15.00</u>
Certified trainer endorsement examination/reexamination	25.00
Certified trainer endorsement renewal	15.00
((Duplicate)) <u>License print fee</u>	((10.00)) <u>5.00</u>

[Statutory Authority: RCW 18.170.180(1). WSR 15-22-109, § 308-18-150, filed 11/4/15, effective 12/5/15. Statutory Authority: Chapter 18.170 RCW. WSR 08-19-056, § 308-18-150, filed 9/12/08, effective 11/1/08. Statutory Authority: Chapter 18.170 RCW and Federal Anti Terrorism and Prevention Act 2004. WSR 07-01-032, § 308-18-150, filed 12/12/06, effective 2/15/07; WSR 05-24-121, § 308-18-150, filed 12/7/05, effective 1/9/06. Statutory Authority: Chapter 18.170 RCW. WSR 04-12-023, § 308-18-150, filed 5/26/04, effective 7/1/04. Statutory Authority: RCW 43.24.086 and chapter 18.170 RCW. WSR 02-07-068, § 308-18-150, filed 3/18/02, effective 7/1/02. Statutory Authority: Chapter 18.170 RCW. WSR 98-24-045, § 308-18-150, filed 11/25/98, effective 1/1/99. Statutory Authority: RCW 18.170.180(1), 43.24.086 and 34.05.482. WSR 97-17-050, § 308-18-150, filed 8/15/97, effective 9/15/97. Statutory Authority: RCW 18.170 [18.170.180](1). WSR 93-11-025, § 308-18-150, filed 5/7/93, effective 7/1/93. Statutory Authority: RCW 18.170.180. WSR 91-22-112, § 308-18-150, filed 11/6/91, effective 12/7/91.]

OTS-3948.1

AMENDATORY SECTION (Amending WSR 16-13-002, filed 6/1/16, effective 7/2/16)

WAC 308-19-130 Bail bond recovery agent, bail bond agency, branch office and bail bond agent fees. The following fees for a one-year period shall be charged by business and professions division of the department of licensing:

Title of Fee	Fee
Bail bond agency/branch office:	
Application	((\$1,200.00)) <u>\$740.00</u>
License renewal	((1,150.00)) <u>615.00</u>
Late renewal ((with)) penalty	((1,200.00)) <u>60.00</u>
Bail bond agent:	
Original license	((500.00)) <u>540.00</u>
License renewal	((575.00)) <u>615.00</u>
Late renewal ((with)) penalty	((600.00)) <u>35.00</u>
Change of qualified agent	250.00
Original endorsement to the bail bond agent license	100.00
Endorsement renewal	100.00
Endorsement renewal with penalty	150.00
Bail bond recovery agent license:	
Original license plus current applicable background check fees	((450.00)) <u>490.00</u>
License renewal	((475.00)) <u>515.00</u>
Late renewal ((with)) penalty	((500.00)) <u>35.00</u>
Examinations:	
Reexamination fee	25.00
<u>License print fee</u>	<u>5.00</u>

[Statutory Authority: RCW 18.235.030(1). WSR 16-13-002, § 308-19-130, filed 6/1/16, effective 7/2/16. Statutory Authority: Chapter 18.185 RCW. WSR 08-20-036, § 308-19-130, filed 9/23/08, effective 11/1/08; WSR 06-21-082, § 308-19-130, filed 10/17/06, effective 11/17/06; WSR 05-08-027, § 308-19-130, filed 3/30/05, effective 4/30/05. Statutory Authority: RCW 43.24.086 and chapter 18.185 RCW. WSR 02-07-067, § 308-19-130, filed 3/18/02, effective 7/1/02. Statutory Authority: 1993 c 260 § 13. WSR 93-21-053, § 308-19-130, filed 10/18/93, effective 11/18/93.]

OTS-3949.1

AMENDATORY SECTION (Amending WSR 16-02-033, filed 12/29/15, effective 1/29/16)

WAC 308-20-210 Fees. In addition to any third-party examinations fees, the following fees shall be charged by the professional licensing division of the department of licensing:

Title of Fee	Fee
Cosmetologist:	
License application	((\$25.00)) <u>\$35.00</u>
Reciprocity license	((\$50.00)) <u>60.00</u>
Renewal (two-year license)	((\$55.00)) <u>66.00</u>
Late renewal penalty	((\$55.00)) <u>65.00</u>
((Duplicate)) <u>License print fee</u>	((\$15.00)) <u>5.00</u>
Hair design:	
License application	((\$25.00)) <u>35.00</u>
Reciprocity license	((\$50.00)) <u>60.00</u>
Renewal (two-year license)	((\$55.00)) <u>66.00</u>
Late renewal penalty	((\$55.00)) <u>65.00</u>
((Duplicate)) <u>License print fee</u>	((\$15.00)) <u>5.00</u>
Instructor:	
License application	((\$25.00)) <u>35.00</u>
Reciprocity license	((\$50.00)) <u>60.00</u>
Renewal (two-year license)	((\$55.00)) <u>66.00</u>
Late renewal penalty	((\$55.00)) <u>65.00</u>
((Duplicate)) <u>License print fee</u>	((\$15.00)) <u>5.00</u>
Manicurist:	
License application	((\$25.00)) <u>35.00</u>
Reciprocity license	((\$50.00)) <u>60.00</u>
Renewal (two-year license)	((\$55.00)) <u>66.00</u>
Late renewal penalty	((\$55.00)) <u>65.00</u>
((Duplicate)) <u>License print fee</u>	((\$15.00)) <u>5.00</u>
Esthetician:	

Title of Fee	Fee
License application	((25.00)) <u>35.00</u>
Reciprocity license	((50.00)) <u>60.00</u>
Renewal (two-year license)	((55.00)) <u>66.00</u>
Late renewal penalty	((55.00)) <u>65.00</u>
((Duplicate)) <u>License print fee</u>	((15.00)) <u>5.00</u>
Master esthetician:	
License application	((25.00)) <u>35.00</u>
Reciprocity license	((50.00)) <u>60.00</u>
Renewal (two-year license)	((55.00)) <u>66.00</u>
Late renewal penalty	((55.00)) <u>65.00</u>
((Duplicate)) <u>License print fee</u>	((15.00)) <u>5.00</u>
Barber:	
License application	((25.00)) <u>35.00</u>
Reciprocity license	((50.00)) <u>60.00</u>
Renewal (two-year license)	((55.00)) <u>66.00</u>
Late renewal penalty	((55.00)) <u>65.00</u>
((Duplicate)) <u>License print fee</u>	((15.00)) <u>5.00</u>
School:	
License application	((300.00)) <u>330.00</u>
Renewal (one-year license)	((300.00)) <u>330.00</u>
Late renewal penalty	((175.00)) <u>193.00</u>
((Duplicate)) <u>License print fee</u>	((15.00)) <u>5.00</u>
Salon/shop:	
License application	((110.00)) <u>121.00</u>
*Reduced license application (permanent cosmetics)	15.00
Renewal (one-year license)	((110.00)) <u>121.00</u>
*Reduced renewal (permanent cosmetics)	15.00
Late renewal penalty	((50.00)) <u>60.00</u>
((Duplicate)) <u>License print fee</u>	((15.00)) <u>5.00</u>
Mobile unit:	

Title of Fee	Fee
License application	((110.00)) <u>121.00</u>
*Reduced license application (permanent cosmetics)	15.00
Renewal (one-year license)	((110.00)) <u>121.00</u>
*Reduced renewal (permanent cosmetics)	15.00
Late renewal penalty	((50.00)) <u>60.00</u>
((Duplicate)) License print fee	((15.00)) <u>5.00</u>
Personal services:	
License application	((110.00)) <u>121.00</u>
*Reduced license application (permanent cosmetics)	15.00
Renewal (one-year license)	((110.00)) <u>121.00</u>
*Reduced renewal (permanent cosmetics)	15.00
Late renewal penalty	((50.00)) <u>60.00</u>
((Duplicate)) License print fee	((15.00)) <u>5.00</u>

* If you have an individual artist license and an artist shop location license to practice permanent cosmetics under chapter 18.300 RCW, and an operator license under chapter 18.16 RCW you may qualify for a reduction of the license fee for your salon shop license if it is at the same location as your artist shop location license.

[Statutory Authority: RCW 18.16.030, 43.24.023, 43.24.086. WSR 16-02-033, § 308-20-210, filed 12/29/15, effective 1/29/16. Statutory Authority: RCW 43.24.023 and 18.16.030. WSR 13-24-042, § 308-20-210, filed 11/26/13, effective 1/1/14. Statutory Authority: RCW 43.24.086 and 18.16.030. WSR 09-24-062, § 308-20-210, filed 11/25/09, effective 1/1/10; WSR 06-02-048, § 308-20-210, filed 12/29/05, effective 2/1/06. Statutory Authority: RCW 18.16.030 and 43.24.023. WSR 03-14-046, § 308-20-210, filed 6/24/03, effective 7/25/03. Statutory Authority: RCW 18.16.030 and 43.24.086. WSR 03-06-054, § 308-20-210, filed 2/28/03, effective 4/1/03. Statutory Authority: RCW 18.16.030, 43.24.086, and 43.135.055. WSR 02-09-040, § 308-20-210, filed 4/12/02, effective 1/1/03. Statutory Authority: Chapter 18.16 RCW. WSR 92-15-087, § 308-20-210, filed 7/17/92, effective 8/17/92. Statutory Authority: Chapter 18.16 RCW and RCW 34.05.220. WSR 92-04-006, § 308-20-210, filed 1/23/92, effective 2/23/92. Statutory Authority: RCW 18.16.030 and 43.24.086. WSR 90-07-030, § 308-20-210, filed 3/14/90, effective 4/14/90. Statutory Authority: RCW 43.24.086. WSR 87-10-028 (Order PM 650), § 308-20-210, filed 5/1/87.]

OTS-3950.1

AMENDATORY SECTION (Amending WSR 10-14-074, filed 7/1/10, effective 7/1/10)

WAC 308-22-050 Fees. The following fees shall be charged by the professional licensing division of the department of licensing. The department may require payment of fees less than those established in this section if the current level of fees is likely to result in a surplus of funds. Surplus funds are those in excess of the amount necessary to pay for the costs of administering the program and to maintain a reasonable reserve.

Title of Fee	Fee
Individual License:	
Tattoo	\$ ((250)) <u>275</u>
Body Art	\$ ((250)) <u>275</u>
Body Piercing	\$ ((250)) <u>275</u>
Permanent Cosmetics	\$ ((250)) <u>275</u>
Location License:	
Shop/Business	\$ ((300)) <u>330</u>
Mobile Unit	\$ ((300)) <u>330</u>
Event	\$ ((300)) <u>330</u>
Individual License Renewal:	
Tattoo	\$ ((250)) <u>275</u>
Body Art	\$ ((250)) <u>275</u>
Body Piercing	\$ ((250)) <u>275</u>
Permanent Cosmetics	\$ ((250)) <u>275</u>
Location License Renewal:	
Shop/Business	\$ ((300)) <u>330</u>
Mobile Unit	\$ ((300)) <u>330</u>
Event	\$ ((300)) <u>330</u>
Individual License Late Renewal Penalty Fee:	
Tattoo	\$ ((350)) <u>110</u>
Body Art	\$ ((350)) <u>110</u>
Body Piercing	\$ ((350)) <u>110</u>
Permanent Cosmetics	\$ ((350)) <u>110</u>
Location License Late Renewal Penalty Fee:	
Shop/Business	\$ ((400)) <u>110</u>
Mobile Unit	\$ ((400)) <u>110</u>
((Duplicate)) License Print Fee	\$ ((50)) <u>5</u>

[Statutory Authority: RCW 43.24.086, 43.24.023, chapter 18.300 RCW, and 2009 c 412. WSR 10-14-074, § 308-22-050, filed 7/1/10, effective 7/1/10.]

OTS-3952.1

AMENDATORY SECTION (Amending WSR 18-12-028, filed 5/29/18, effective 7/1/18)

WAC 308-30-060 Application fees. The following fees shall be charged by the department:

Title of Fee	Fee
Application for notary public commission	((\$30.00)) <u>\$40.00</u>
Application for electronic records notary public endorsement	\$15.00
Renewal of notary public commission	((\$30.00)) <u>\$42.00</u>
Renewal of electronic records notary public endorsement	\$15.00
((Duplicate certificate of commission (including name change))) <u>License print fee</u>	((\$15.00)) <u>\$5.00</u>

[Statutory Authority: RCW 42.45.250. WSR 18-12-028, § 308-30-060, filed 5/29/18, effective 7/1/18. Statutory Authority: RCW 42.44.190. WSR 93-05-009, § 308-30-060, filed 2/5/93, effective 3/8/93. Statutory Authority: 1985 c 156 §§ 5 and 20. WSR 85-24-025 (Order PL 571), § 308-30-060, filed 11/26/85, effective 1/1/86.]

OTS-3958.1

AMENDATORY SECTION (Amending WSR 07-16-036, filed 7/23/07, effective 9/1/07)

WAC 308-129-110 Seller of travel registration fees. The following fees shall be charged by the business and professions division of the department of licensing:

Title of Fee	Fee
Original registration fee	((\$202.00)) <u>\$222.00</u>
Registration renewal	((202.00)) <u>222.00</u>
Service of process fee	20.00

Branch offices are subject to a duplicate registration fee. The duplicate registration fee for each branch office shall be an amount equal to the original registration fee.

[Statutory Authority: RCW 19.138.170 and 43.24.086. WSR 07-16-036, § 308-129-110, filed 7/23/07, effective 9/1/07. Statutory Authority: RCW 19.138.170, 43.24.023, 43.24.086. WSR 04-19-039, § 308-129-110, filed 9/13/04, effective 11/1/04. Statutory Authority: RCW 19.138.170, 43.24.023. WSR 04-12-027, § 308-129-110, filed 5/26/04, effective 7/1/04. Statutory Authority: RCW 19.138.170(1). WSR 00-01-128, § 308-129-110, filed 12/20/99, effective 1/20/00. Statutory Authority: Chapter 19.138 RCW. WSR 96-14-092, § 308-129-110, filed 7/2/96, effective 8/2/96.]

OTS-3960.1

AMENDATORY SECTION (Amending WSR 90-02-060, filed 1/2/90, effective 2/2/90)

WAC 308-320-050 Registration fees. The fee for any commercial telephone solicitor required to register in this state shall be (~~seventy-two dollars~~) \$82 for each business location annually. The annual fee shall be proratable and nonrefundable.

[Statutory Authority: 1989 c 20 and RCW 34.05.220. WSR 90-02-060, § 308-320-050, filed 1/2/90, effective 2/2/90.]

AMENDATORY SECTION (Amending WSR 90-02-060, filed 1/2/90, effective 2/2/90)

WAC 308-320-060 Annual renewal dates, forms, and fees. Registration renewals must be made annually on the form and date required by the department. The fee for annual renewal shall be (~~seventy-two dollars~~) \$82.

[Statutory Authority: 1989 c 20 and RCW 34.05.220. WSR 90-02-060, § 308-320-060, filed 1/2/90, effective 2/2/90.]

AMENDATORY SECTION (Amending WSR 90-02-060, filed 1/2/90, effective 2/2/90)

WAC 308-320-070 Changes and fees. Registrants shall inform the department of any changes in filed information when the change occurs.

(1) Changes in ownership or ownership structure or a change of more than (~~fifty~~) 50 percent of the partners in a partnership requires submission of a new master business application, new supplemental information statement, new personal history statement(s), and a fee of (~~seventy-two dollars~~) \$82 for each business location.

(2) Changes in business location requires a new master business application and a fee of (~~seventy-two dollars~~) \$82.

(3) Changes in managers, general partners of a limited partnership, partners in a general partnership or the president, vice president, secretary or treasurer of a corporation requires completion of a personal history form for the new individual(s).

(4) Changes in the business mailing address or the location where business records are kept shall be made in writing.

[Statutory Authority: 1989 c 20 and RCW 34.05.220. WSR 90-02-060, § 308-320-070, filed 1/2/90, effective 2/2/90.]

OTS-3961.1

AMENDATORY SECTION (Amending WSR 09-13-001, filed 6/3/09, effective 7/4/09)

WAC 308-408A-090 Home inspector fees. These fees are applicable to all original licenses, examination services, and fee generating services. The following fees shall be charged by professional licensing services of the department of licensing:

TITLE OF FEE	FEE
Home Inspector:	
Application/examination	\$300
Reexamination	
Full	\$300
National portion	\$250
State portion	\$125
Original license	((\$680))
	<u>\$720</u>
License renewal	((\$375))
	<u>\$415</u>
Late renewal ((with)) penalty	((\$435))
	<u>\$70</u>
Reinstatement penalty fine	\$150
Course review	((\$75))
	<u>\$85</u>

[Statutory Authority: RCW 18.280.050 and 18.280. [18.280.060] (6). WSR 09-13-001, § 308-408A-090, filed 6/3/09, effective 7/4/09.]

OTS-3962.1

AMENDATORY SECTION (Amending WSR 02-15-168, filed 7/23/02, effective 1/1/03)

WAC 308-420-240 Fees and charges. The following fees shall be paid under the provisions of chapter 19.105 RCW:

TITLE OF FEE	FEE
(1) Original registration:	
One camping resort	((\$3,200.00))
	<u>\$3,240.00</u>
Each additional camping resort in this state	((1,000.00))
	<u>1,040.00</u>
(2) Contract fees:	
One to five hundred contracts	500.00
Each additional five hundred contracts, or fraction thereof	100.00
(3) Renewal fees:	
Annual renewal	((2,000.00))
	<u>2,040.00</u>
Each additional camping resort in this state	((800.00))
	<u>840.00</u>

TITLE OF FEE	FEE
Contract fees as described in subsection (2) of this section for each grouping of contracts:	
One to five hundred contracts	500.00
Each additional five hundred contracts, or fraction thereof	100.00
Late renewal penalty	((800.00)) <u>840.00</u>
(4) Fees for amending registration and public offering statements:	
For each amendment of registration or the public offering statement, not requiring an examination of documentation for adding campground or additional contracts to registration	50.00
Amendment for the establishment of an additional campground into the registration for which an examination of documents is required exclusive of any other fees	1,500.00
Penalty fee for failure to file an amendment within thirty days of the occurrence of a material change as defined in WAC 308-420-030 or 308-420-040	100.00
(5) Fees for impounds, escrows, trust and depositories:	
For each initial establishment of impound, escrow, trust or other arrangement requiring agency monitoring	250.00
Each required periodic report	20.00
(6) Advertising filings:	
Each individual advertisement filed with the department	100.00
Advertisement involving no examination of campground instruments and which are for the purpose of marketing surveys or feasibility studies	75.00
(7) Salesperson fees:	
Registration	((150.00)) <u>165.00</u>
Renewal	((150.00)) <u>165.00</u>
Transfer	150.00
((Duplicate)) <u>Print license fee</u>	((35.00)) <u>5.00</u>
(8) Fees for exemptions and exemption applications:	
Review of application for exemption under RCW 19.105.320(2)	150.00

- | TITLE OF FEE | FEE |
|---|-----|
| (9) All fees are nonrefundable after the application has been received. | |
| (10) All fees shall be paid to the order of the Washington state treasurer. | |

[Statutory Authority: RCW 19.105.411, 43.24.086, and 2001 c 7. WSR 02-15-168, § 308-420-240, filed 7/23/02, effective 1/1/03. Statutory Authority: RCW 19.105.411 and 43.240.086. WSR 98-18-082, § 308-420-240, filed 9/1/98, effective 10/2/98. Statutory Authority: RCW 19.105.130. WSR 91-01-082, § 308-420-240, filed 12/17/90, effective 1/17/91. Formerly WAC 460-90A-145.]

WSR 22-22-027

PERMANENT RULES

WENATCHEE VALLEY COLLEGE

[Filed October 24, 2022, 1:04 p.m., effective November 24, 2022]

Effective Date of Rule: Thirty-one days after filing.

Purpose: Changing language about transcripts being withheld due to nonpayment.

Citation of Rules Affected by this Order: New WAC 132W-125-010.

Statutory Authority for Adoption: RCW 28B.50.140.

Adopted under notice filed as WSR 22-13-0775 [22-13-077] on June 10, 2022.

Number of Sections Adopted in Order to Comply with Federal Statute: New 0, Amended 0, Repealed 0; Federal Rules or Standards: New 0, Amended 0, Repealed 0; or Recently Enacted State Statutes: New 0, Amended 0, Repealed 0.

Number of Sections Adopted at the Request of a Nongovernmental Entity: New 0, Amended 0, Repealed 0.

Number of Sections Adopted on the Agency's own Initiative: New 0, Amended 0, Repealed 0.

Number of Sections Adopted in Order to Clarify, Streamline, or Reform Agency Procedures: New 0, Amended 0, Repealed 0.

Number of Sections Adopted using Negotiated Rule Making: New 0, Amended 0, Repealed 0; Pilot Rule Making: New 0, Amended 0, Repealed 0; or Other Alternative Rule Making: New 0, Amended 0, Repealed 0.

Date Adopted: October 19, 2022.

Jim Richardson
President

OTS-3689.1

AMENDATORY SECTION (Amending WSR 14-08-013, filed 3/20/14, effective 4/20/14)

WAC 132W-125-010 Statement of policy. The college expects that students, staff members, faculty members, or former students who receive services for which a financial obligation is incurred will exercise responsibility in meeting these obligations. Appropriate college staff are empowered to act in accordance with regularly adopted procedures to carry out the intent of this policy, and if necessary to initiate legal action to insure that collection matters are brought to a timely and satisfactory conclusion.

~~((Admission to or registration with the college, conferring of degrees and issuance of academic transcripts may be withheld for failure to meet financial obligations to the college.))~~ If any person, including faculty member, staff member, student, or former student, is indebted to the institution for an outstanding overdue debt, the institution need not provide any further services of any kind to such individual including, but not limited to, admission, course registration, library access, transmitting files, records, or other services which have been requested by such person.

[Statutory Authority: RCW 28B.50.140(13). WSR 14-08-013, § 132W-125-010, filed 3/20/14, effective 4/20/14. Statutory Authority: Chapter 28B.50 RCW. WSR 01-12-015, § 132W-125-010, filed 5/25/01, effective 6/25/01.]

WSR 22-22-038

PERMANENT RULES

DEPARTMENT OF HEALTH

(Washington Medical Commission)

[Filed October 25, 2022, 4:38 p.m., effective November 25, 2022]

Effective Date of Rule: Thirty-one days after filing.

Purpose: WAC 246-919-345 Limited physician and surgeon clinical experience license for international medical graduates. The Washington medical commission is adopting a new section to chapter 246-919 WAC to implement SB 6551 (chapter 325, Laws of 2020) concerning licensure of international medical graduates.

Citation of Rules Affected by this Order: New WAC 246-919-345.

Statutory Authority for Adoption: RCW 18.71.017 and 18.130.050.

Adopted under notice filed as WSR 22-15-039 on July 14, 2022.

Changes Other than Editing from Proposed to Adopted Version: The adopted rule includes some minor clarifying grammatical changes in subsections (1) and (2). The changes included punctuation and removing unnecessary words. There is also a correction to align the name of the license in subsection (3).

A final cost-benefit analysis is available by contacting Amelia Boyd, P.O. Box 47866, Olympia, WA 98504, phone 360-918-6336, TTY 711, email amelia.boyd@wmc.wa.gov, website www.wmc.wa.gov.

Number of Sections Adopted in Order to Comply with Federal Statute: New 0, Amended 0, Repealed 0; Federal Rules or Standards: New 0, Amended 0, Repealed 0; or Recently Enacted State Statutes: New 1, Amended 0, Repealed 0.

Number of Sections Adopted at the Request of a Nongovernmental Entity: New 0, Amended 0, Repealed 0.

Number of Sections Adopted on the Agency's own Initiative: New 0, Amended 0, Repealed 0.

Number of Sections Adopted in Order to Clarify, Streamline, or Reform Agency Procedures: New 0, Amended 0, Repealed 0.

Number of Sections Adopted using Negotiated Rule Making: New 0, Amended 0, Repealed 0; Pilot Rule Making: New 0, Amended 0, Repealed 0; or Other Alternative Rule Making: New 1, Amended 0, Repealed 0.

Date Adopted: August 26, 2022.

Melanie de Leon
Executive Director

OTS-3589.4

NEW SECTION

WAC 246-919-345 Limited physician and surgeon clinical experience license. (1) The commission may issue a limited physician and surgeon clinical experience license to an applicant who does not qualify for licensure under RCW 18.71.050 or chapter 18.71B RCW and who does meet the requirements established in RCW 18.71.095(6) for the purpose of gaining clinical experience at an approved facility or program.

(2) An appropriate medical practice, as referenced in RCW 18.71.095 (6) (a), is a practice that meets the following criteria:

(a) The practice is physically located in the state of Washington and is providing clinical care to Washington patients.

(b) The practice falls within one of the following categories:

(i) Is a practice setting within a federal system such as military, Indian health services, tribal health setting, or community health center; or

(ii) Is a practice setting that:

(A) Has three or more physicians for the purposes of delivering direct patient care; and

(B) Has a quality review, improvement, and assurance program for practitioners.

(3) Prior to commencing practice, a limited physician and surgeon clinical experience license holder must file a practice agreement with the commission.

(4) To apply for a limited physician and surgeon clinical experience license, an applicant shall submit to the commission:

(a) An application provided by the commission; and

(b) Applicable fees as established in WAC 246-919-990.

[]

WSR 22-22-039**PERMANENT RULES****DEPARTMENT OF HEALTH**

(Washington Medical Commission)

[Filed October 25, 2022, 4:42 p.m., effective November 25, 2022]

Effective Date of Rule: Thirty-one days after filing.

Purpose: The Washington medical commission (commission) is amending WAC 246-918-801 Exclusions (physician assistants), and 246-919-851 Exclusions (physicians), to expand the types of patients who are exempt from certain provisions of rule when being prescribed opioid drugs.

Citation of Rules Affected by this Order: Amending WAC 246-918-801 and 246-919-851.

Statutory Authority for Adoption: RCW 18.71A.800, 18.71.017, and 18.130.050.

Adopted under notice filed as WSR 22-09-071 on April 19, 2022.

Changes Other than Editing from Proposed to Adopted Version: The proposed rule struck language that explained that an inpatient is a patient who has been admitted to a hospital for more than 24 hours. The adopted rule includes the clarification that an inpatient is a patient that has been admitted to the list of facilities included in the adopted rule for more than 24 hours.

A final cost-benefit analysis is available by contacting Amelia Boyd, P.O. Box 47866, Olympia, WA 98504, phone 360-918-6336, TTY 711, email amelia.boyd@wmc.wa.gov, website www.wmc.wa.gov.

Number of Sections Adopted in Order to Comply with Federal Statute: New 0, Amended 0, Repealed 0; Federal Rules or Standards: New 0, Amended 0, Repealed 0; or Recently Enacted State Statutes: New 0, Amended 0, Repealed 0.

Number of Sections Adopted at the Request of a Nongovernmental Entity: New 0, Amended 0, Repealed 0.

Number of Sections Adopted on the Agency's own Initiative: New 0, Amended 2, Repealed 0.

Number of Sections Adopted in Order to Clarify, Streamline, or Reform Agency Procedures: New 0, Amended 0, Repealed 0.

Number of Sections Adopted using Negotiated Rule Making: New 0, Amended 0, Repealed 0; Pilot Rule Making: New 0, Amended 0, Repealed 0; or Other Alternative Rule Making: New 0, Amended 2, Repealed 0.

Date Adopted: May 27, 2022.

Melanie de Leon
Executive Director

OTS-3321.3

Physician Assistants

AMENDATORY SECTION (Amending WSR 18-23-061, filed 11/16/18, effective 1/1/19)

WAC 246-918-801 Exclusions. WAC 246-918-800 through 246-918-935 do not apply to:

- (1) The treatment of patients with cancer-related pain;
- (2) The provision of palliative, hospice, or other end-of-life care;
- (3) ~~((The treatment of inpatient hospital patients who are patients who have been admitted to a hospital for more than twenty-four hours; or~~
 - (4)) The provision of procedural medications;
- (4) The treatment of patients who have been admitted to any of the following facilities for more than 24 hours:
 - (a) Acute care hospitals licensed under chapter 70.41 RCW;
 - (b) Psychiatric hospitals licensed under chapter 71.12 RCW;
 - (c) Nursing homes licensed under chapter 18.51 RCW and nursing facilities as defined in WAC 388-97-0001;
 - (d) Long-term acute care hospitals as defined in RCW 74.60.010;

or

 - (e) Residential treatment facilities as defined in RCW 71.12.455;

or
- (5) The treatment of patients in residential habilitation centers as defined in WAC 388-825-089 when the patient has been transferred directly from a facility listed in subsection (4) of this section.

[Statutory Authority: RCW 18.71.017, 18.71.800, 18.71A.800 and 2017 c 297. WSR 18-23-061, filed 11/16/18, effective 1/1/19. Statutory Authority: RCW 18.71.450, 18.71A.100, 18.71.017, and 18.71A.020. WSR 11-12-025, § 246-918-801, filed 5/24/11, effective 1/2/12.]

OTS-3322.2

Physicians

AMENDATORY SECTION (Amending WSR 18-23-061, filed 11/16/18, effective 1/1/19)

WAC 246-919-851 Exclusions. WAC 246-919-850 through 246-919-985 do not apply to:

- (1) The treatment of patients with cancer-related pain;
- (2) The provision of palliative, hospice, or other end-of-life care;
- (3) ~~((The treatment of inpatient hospital patients who are patients who have been admitted to a hospital for more than twenty-four hours; or~~
 - (4)) The provision of procedural medications;

(4) The treatment of patients who have been admitted to any of the following facilities for more than 24 hours:

(a) Acute care hospitals licensed under chapter 70.41 RCW;

(b) Psychiatric hospitals licensed under chapter 71.12 RCW;

(c) Nursing homes licensed under chapter 18.51 RCW and nursing facilities as defined in WAC 388-97-0001;

(d) Long-term acute care hospitals as defined in RCW 74.60.010;

or

(e) Residential treatment facilities as defined in RCW 71.12.455;

or

(5) The treatment of patients in residential habilitation centers as defined in WAC 388-825-089 when the patient has been transferred directly from a facility listed in subsection (4) of this section.

[Statutory Authority: RCW 18.71.017, 18.71.800, 18.71A.800 and 2017 c 297. WSR 18-23-061, § 246-919-851, filed 11/16/18, effective 1/1/19. Statutory Authority: RCW 18.71.450, 18.71A.100, 18.71.017, and 18.71A.020. WSR 11-12-025, § 246-919-851, filed 5/24/11, effective 1/2/12.]

WSR 22-22-049

PERMANENT RULES

HEALTH CARE AUTHORITY

[Filed October 27, 2022, 10:27 a.m., effective January 1, 2023]

Effective Date of Rule: January 1, 2023.

Purpose: The agency amended these rules to clarify the change in scope and reconciliation policies and add an end date to WAC 182-549-1400(8) and 182-548-1400(8) to align with the APM4 Memorandum of Understanding (MOU), a new section on appeals, and housekeeping changes.

Chapters 182-548 and 182-549 WAC, housekeeping changes throughout.

WAC 182-548-1100 and 182-549-1100, added definitions for "Cost center," "Encounter-eligible client," and "Medicare economic index (MEI)." Updated the "Encounter" definition to include telemedicine and audio-only telemedicine.

WAC 182-548-1200 and 182-549-1200, added language "properly completed" in reference to enrollment packets and core provider agreements (CPA).

WAC 182-548-1200 (2)(b), added language to clarify that both the enrollment packet AND the CPA must be received.

WAC 182-548-1400 (3)(b), changed language from "increased" to "adjusted" as the MEI could be an increase or a decrease.

WAC 182-549-1400 (3)(b), updated language to avoid delays in setting a final RHC encounter rate.

WAC 182-548-1400(8) and 182-549-1400(8), added end date of the payment methodology to align with MOU for participating federally qualified health centers (FQHCs) and rural health clinics (RHCs).

WAC 182-548-1450 and 182-549-1450 (1)(a) and (b), (2), (3), added language regarding one encounter per day limitation and appropriate exceptions.

WAC 182-548-1450 and 182-549-1450(4), added new subsection to address circumstances where there are additional visits resulting in additional encounters.

WAC 182-548-1450 (7)(b)(iii)(A) and (B), added new subsection regarding prospective enhancement payment adjustments related to over and underpayments.

WAC 182-549-1450 (7)(a)(ii)(C), (D), and (E), added new subsection regarding prospective enhancement payment adjustments related to over and under payments.

WAC 182-548-1500 and 182-549-1500, added new subsection (2)(d)(i), (ii), (A) and (B) to allow more flexibility for submitting a change in scope.

WAC 182-548-1500 and 182-549-1500, added new subsection (2)(d)(viii) to clarify effective date for prospective change in scope supported by less than 12 months of data.

WAC 182-548-1500 and 182-549-1500 (3)(a), added language to include agency email address; a clarification to the submission process.

WAC 182-548-1500 and 182-549-1500 (4)(a)(ii), added language regarding documentation submission to clarify denial process.

WAC 182-548-1500 and 182-549-1500 (4)(b)(ii), removed language; clarified the language and moved to change in scope subsection (2)(d).

WAC 182-548-1500 and 182-549-1500, added new subsections (5)(b)(ii), (iii), and (iv), to clarify documentation the agency requires for post change in scope review.

WAC 182-548-1500 and 182-549-1500(6), removed section, created new appeals section.

WAC 182-548-1600 and 182-549-1600, new section appeals related to overpayments to reflect procedures in which FQHCs and RHCs can appeal their overpayments.

WAC 182-548-1650 and 182-549-1650, new section appeals related to rate setting to reflect the appropriate criteria for appeals related to FQHC and RHC rate setting.

Citation of Rules Affected by this Order: New WAC 182-548-1600, 182-548-1650, 182-549-1600 and 182-549-1650; and amending WAC 182-548-1100, 182-548-1200, 182-548-1300, 182-548-1400, 182-548-1450, 182-548-1500, 182-549-1100, 182-549-1200, 182-549-1300, 182-549-1400, 182-549-1450, and 182-549-1500.

Statutory Authority for Adoption: 42 U.S.C. 1396a(bb), 42 U.S.C. 1396d (2) (A); RCW 41.05.021, 41.05.160.

Other Authority: 42 U.S.C. 1396a(bb), 42 U.S.C. 1396d (2) (A); RCW 41.05.021, 41.05.160.

Adopted under notice filed as WSR 22-18-101 on September 7, 2022. Changes Other than Editing from Proposed to Adopted Version:

Proposed/Adopted	WAC Subsection	Reason
WAC 182-548-1450 (1)(a)		
Proposed	(a) ((The visits occur with different health care professionals with different specialties)) <u>There is a subsequent visit due to the client suffering an illness or injury after the first visit that requires separate evaluation and treatment on the same day for unrelated diagnoses; or</u>	The health care authority (HCA) determined the examples provided in public comment may be allowable and revised the language to remove confusion.
Adopted	(a) ((The visits occur with different health care professionals with different specialties)) <u>There is a subsequent visit in the same cost center that requires separate evaluation and treatment on the same day for unrelated diagnoses; or</u>	
WAC 182-548-1450 (4)(a)		
Proposed	(a) <u>FQHCs must not split services into multiple encounters unless there is clinical justification. (For example, fluoride treatment and sealants must be provided on the same day as an encounter-eligible service.)</u>	As a result of the revision in WAC 182-548-1450 (1)(a) related to public comment, HCA removed "and sealants" from the example in subsection (4)(a) "fluoride treatment and sealants" to avoid potential confusion for providers related to a dental service that is commonly provided on a separate visit.
Adopted	(a) <u>FQHCs must not split services into multiple encounters unless there is clinical justification. (For example, fluoride treatment must be provided on the same day as an encounter-eligible service.)</u>	
WAC 182-549-1450 (1)(a)		
Proposed	(a) ((The visits occur with different health care professionals with different specialties)) <u>There is a subsequent visit due to the client suffering an illness or injury after the first visit that requires separate evaluation and treatment on the same day for unrelated diagnoses; or</u>	To align with changes made in WAC 182-548-1450 (1)(a).
Adopted	(a) ((The visits occur with different health care professionals with different specialties)) <u>There is a subsequent visit in the same cost center that requires separate evaluation and treatment on the same day for unrelated diagnoses; or</u>	
WAC 182-549-1450 (4)(a)		

Proposed/Adopted	WAC Subsection	Reason
Proposed	(a) RHCs must not split services into multiple encounters unless there is clinical justification. (For example, fluoride treatment and sealants must be provided on the same day as an encounter-eligible service.)	To align with changes made in WAC 182-548-1450 (4)(a).
Adopted	(a) RHCs must not split services into multiple encounters unless there is clinical justification. (For example, fluoride treatment must be provided on the same day as an encounter-eligible service.)	

Number of Sections Adopted in Order to Comply with Federal Statute: New 0, Amended 2, Repealed 0; Federal Rules or Standards: New 0, Amended 0, Repealed 0; or Recently Enacted State Statutes: New 0, Amended 0, Repealed 0.

Number of Sections Adopted at the Request of a Nongovernmental Entity: New 0, Amended 0, Repealed 0.

Number of Sections Adopted on the Agency's own Initiative: New 4, Amended 12, Repealed 0.

Number of Sections Adopted in Order to Clarify, Streamline, or Reform Agency Procedures: New 4, Amended 12, Repealed 0.

Number of Sections Adopted using Negotiated Rule Making: New 0, Amended 0, Repealed 0; Pilot Rule Making: New 0, Amended 0, Repealed 0; or Other Alternative Rule Making: New 4, Amended 12, Repealed 0.

Date Adopted: October 27, 2022.

Wendy Barcus
Rules Coordinator

OTS-4021.3

AMENDATORY SECTION (Amending WSR 15-11-008, filed 5/7/15, effective 6/7/15)

WAC 182-548-1100 Federally qualified health centers—Definitions. This section contains definitions of words or phrases that apply to this chapter. Unless defined in this chapter (~~(or)~~), the definitions found in chapter 182-500 WAC (, the definitions found in the Webster's New World Dictionary) apply.

"APM index" - The agency uses the alternative payment methodology (APM) (~~is used~~) to update APM encounter payment rates on an annual basis. The APM index is a measure of input price changes experienced by Washington's federally qualified health center (FQHC) and rural health clinic (RHC) providers. The index is derived from the federal medicare economic index (MEI) and Washington-specific variable measures.

"Base year" - The year that is used as the benchmark in measuring (~~a center's~~) an FQHC's total reasonable costs for establishing base encounter rates.

"Cost center" - A category of service approved to be provided by the FQHC under WAC 182-548-1200 and reported in the medicaid cost report. The categories of services provided by the FQHC may include medical, mental health, dental, maternity support services, and substance use disorder.

"Cost report" - A statement of costs and provider utilization that occurred during the time period covered by the cost report. FQHCs ~~((must))~~ complete a cost report when there is a request for a change in scope rate adjustment, there is a rebasing of the encounter rate, or ~~((when))~~ the ~~((medicaid))~~ agency sets a base rate.

"Encounter" - A face-to-face or telemedicine (including audio-only telemedicine) visit between ~~((a))~~ an encounter-eligible client and ~~((a))~~ an FQHC provider ~~((e.g., a physician, physician's assistant, or advanced registered nurse practitioner))~~ who exercises independent judgment when providing services that qualify for ~~((an))~~ encounter rate reimbursement.

"Encounter-eligible client" - A client who receives benefits under Title XIX (medicaid) or Title XXI (CHIP).

"Encounter rate" - A cost-based, facility-specific rate for covered FQHC services ~~((, paid to an FQHC for each valid encounter it bills))~~.

"Enhancements (also called managed care enhancements)" - A monthly amount ~~((paid by))~~ the agency pays to FQHCs for each client enrolled with a managed care organization (MCO). ~~((MCOs))~~ FQHCs may contract with ~~((FQHCs))~~ MCOs to provide services under managed care programs. FQHCs receive enhancements from the agency in addition to the negotiated payments they receive from the MCOs for services provided to enrollees.

"Federally qualified health center (FQHC)" - An entity that has entered into an agreement with the Centers for Medicare and Medicaid Services (CMS) to meet medicare program requirements under 42 C.F.R. 405.2434 and:

~~((1))~~ (a) Is receiving a grant under section 329, 330, or 340 of the federal Public Health Service (PHS) Act, or is receiving funding from such a grant under a contract with the recipient of such a grant and meets the requirements to receive a grant under section 330 of the ~~((Public Health Service))~~ PHS Act;

~~((2))~~ (b) Based on the recommendation of the PHS, is determined by CMS to meet the requirements for receiving such a grant;

~~((3))~~ (c) Was treated by CMS, for purposes of medicare part B, as a comprehensive federally funded health center (FFHC) as of January 1, 1990; or

~~((4))~~ (d) Is an outpatient health program or facility operated by a tribe or tribal organization under the federal Indian Self-Determination and Education Assistance Act of 1975 or ~~((by))~~ an Urban Indian organization receiving funding under Title V of the federal Indian Health Care Improvement Act of 1976.

"Fee-for-service" - A payment method the agency uses to pay providers for covered medical services provided to Washington apple health clients, ~~((except those))~~ which excludes services provided ~~((under))~~ by the agency's ~~((prepaid))~~ contracted managed care organizations ~~((or those))~~ and services that qualify for an encounter rate.

"Interim rate" - The rate ~~((established by))~~ the agency establishes to pay an FQHC for covered FQHC services prior to the establishment of a permanent rate for that ~~((facility))~~ FQHC.

"Medicare economic index (MEI)" - An index published in the Federal Register used in the calculation of changes to determine allowed charges for physician services. The agency adjusts FQHC encounter rates and enhancement rates by the MEI each year on January 1st.

"Rebasing" - The process of recalculating encounter rates using actual cost report data.

[Statutory Authority: RCW 41.05.021 and 41.05.160. WSR 15-11-008, § 182-548-1100, filed 5/7/15, effective 6/7/15. WSR 11-14-075, recodified as § 182-548-1100, filed 6/30/11, effective 7/1/11. Statutory Authority: RCW 74.08.090, BIPA of 2000 Section 702, sections 201 and 209 of 2009-2011 budget bill, and 42 U.S.C. 1396a(bb). WSR 10-09-002, § 388-548-1100, filed 4/7/10, effective 5/8/10.]

AMENDATORY SECTION (Amending WSR 15-11-008, filed 5/7/15, effective 6/7/15)

WAC 182-548-1200 Federally qualified health centers—Enrollment.

(1) To enroll as a Washington apple health provider and receive payment for services, a federally qualified health center (FQHC) must:

- (a) Receive FQHC certification for participation in the Title XVIII (medicare) program according to 42 C.F.R. 491;
- (b) Sign a core provider agreement with the medicaid agency; and
- (c) Operate in accordance with applicable federal, state, and local laws.

(2) The medicaid agency uses one of two timeliness standards for determining the effective date of a medicaid-certified FQHC.

(a) The agency uses medicare's effective date if the FQHC returns a properly completed core provider agreement and a properly completed FQHC enrollment packet within ((sixty)) 60 calendar days from the date of ((medicare's letter notifying the center)) CMS's written notification to the FQHC of the medicare certification.

(b) The agency uses the date when both the ((signed core provider agreement is)) properly completed FQHC enrollment packet and properly completed core provider agreement have been received if ((the FQHC returns the properly completed core provider agreement and FQHC enrollment packet sixty-one)) either of the required documentation is submitted 61 or more calendar days after the date of medicare's letter notifying the clinic of the medicare certification.

[Statutory Authority: RCW 41.05.021 and 41.05.160. WSR 15-11-008, § 182-548-1200, filed 5/7/15, effective 6/7/15. WSR 11-14-075, recodified as § 182-548-1200, filed 6/30/11, effective 7/1/11. Statutory Authority: RCW 74.08.090, BIPA of 2000 Section 702, sections 201 and 209 of 2009-2011 budget bill, and 42 U.S.C. 1396a(bb). WSR 10-09-002, § 388-548-1200, filed 4/7/10, effective 5/8/10.]

AMENDATORY SECTION (Amending WSR 15-11-008, filed 5/7/15, effective 6/7/15)

WAC 182-548-1300 Federally qualified health centers—Services.

(1) The following outpatient services qualify for FQHC encounter rate reimbursement:

- (a) Physician services specified in 42 C.F.R. 405.2412.
- (b) Nurse practitioner or physician assistant services specified in 42 C.F.R. 405.2414.
- (c) Clinical psychologist and clinical social worker services specified in 42 C.F.R. 405.2450.

- (d) Visiting nurse services specified in 42 C.F.R. 405.2416.
- (e) Nurse-midwife services specified in 42 C.F.R. 405.2401.
- (f) Preventive primary services specified in 42 C.F.R. 405.2448.
- (2) The medicaid agency pays for FQHC services when they are:
 - (a) Within the scope of an encounter-eligible client's Washington apple health program. Refer to WAC 182-501-0060 scope of services; and
 - (b) Medically necessary as defined in WAC 182-500-0070.
- (3) FQHC services may be provided by any of the following individuals in accordance with 42 C.F.R. 405.2446:
 - (a) Physicians;
 - (b) Physician assistants (PA);
 - (c) Nurse practitioners (NP);
 - (d) Nurse midwives or other specialized nurse practitioners;
 - (e) Certified nurse midwives;
 - (f) Registered nurses or licensed practical nurses; and
 - (g) Psychologists or clinical social workers.

[Statutory Authority: RCW 41.05.021 and 41.05.160. WSR 15-11-008, § 182-548-1300, filed 5/7/15, effective 6/7/15. WSR 11-14-075, recodified as § 182-548-1300, filed 6/30/11, effective 7/1/11. Statutory Authority: RCW 74.08.090, BIPA of 2000 Section 702, sections 201 and 209 of 2009-2011 budget bill, and 42 U.S.C. 1396a(bb). WSR 10-09-002, § 388-548-1300, filed 4/7/10, effective 5/8/10.]

AMENDATORY SECTION (Amending WSR 20-24-083, filed 11/25/20, effective 1/1/21)

WAC 182-548-1400 Federally qualified health centers—Payment methodologies. (1) For services provided during the period beginning January 1, 2001, and ending December 31, 2008, the medicaid agency's payment methodology for federally qualified health centers (FQHC) was a prospective payment system (PPS) as authorized by 42 U.S.C. 1396a (bb) (2) and (3).

(2) For services provided beginning January 1, 2009, FQHCs have the choice to be reimbursed under the PPS or to be reimbursed under an alternative payment methodology (APM), as authorized by 42 U.S.C. 1396a (bb) (6). As required by 42 U.S.C. 1396a (bb) (6), payments made under the APM (~~((will be))~~) are at least as much as payments that would have been made under the PPS.

(3) The agency calculates FQHC PPS encounter rates as follows:

- (a) Until an FQHC's first audited medicaid cost report is available, the agency pays an average encounter rate of other similar FQHCs within the state, otherwise known as an interim rate.
- (b) Upon availability of the FQHC's first audited medicaid cost report, the agency sets FQHC encounter rates at (~~((one hundred))~~) 100 percent of its total reasonable costs as defined in the cost report. FQHCs receive this rate for the remainder of the calendar year during which the audited cost report became available. The encounter rate is then (~~((increased))~~) adjusted each January 1st by the percent change in the medicare economic index (MEI).

(4) For FQHCs in existence during calendar years 1999 and 2000, the agency sets encounter rates prospectively using a weighted average of (~~((one hundred))~~) 100 percent of the FQHC's total reasonable costs for calendar years 1999 and 2000 and adjusted for any increase or de-

crease in the scope of services furnished during the calendar year 2001 to establish a base encounter rate.

(a) The agency adjusts PPS base encounter rates to account for an increase or decrease in the scope of services provided during calendar year 2001 in accordance with WAC 182-548-1500.

(b) The agency determines PPS base encounter rates (~~(are determined)~~) using audited cost reports, and each year's rate is weighted by the total reported encounters. The agency does not apply a capped amount to these base encounter rates. The formula used to calculate base encounter rates is as follows:

$$\text{Specific FQHC Base Encounter Rate} = \frac{(\text{Year 1999 Rate} \times \text{Year 1999 Encounters}) + (\text{Year 2000 Rate} \times \text{Year 2000 Encounters})}{(\text{Year 1999 Encounters} + \text{Year 2000 Encounters}) \text{ for each FQHC}}$$

(c) Beginning in calendar year 2002 and any year thereafter, encounter rates are (~~(increased)~~) adjusted by the MEI for primary care services, and adjusted for any increase or decrease in the FQHC's scope of services.

(5) The agency calculates the FQHC's APM encounter rate for services provided during the period beginning January 1, 2009, and ending April 6, 2011, as follows:

(a) The APM utilizes the FQHC base encounter rates, as described in subsection (4)(b) of this section.

(b) Base rates are adjusted to reflect any approved changes in scope of service in calendar years 2002 through 2009.

(c) The adjusted base rates are then increased by each annual percentage, from calendar years 2002 through 2009, of the IHS Global Insight index, also called the APM index. The result is the year 2009 APM rate for each FQHC that chooses to be reimbursed under the APM.

(6) This subsection describes the encounter rates that the agency pays FQHCs for services provided during the period beginning April 7, 2011, and ending June 30, 2011. On January 12, 2012, the federal Centers for Medicare and Medicaid Services (CMS) approved a state plan amendment (SPA) containing the methodology outlined in this section.

(a) During the period that CMS approval of the SPA was pending, the agency continued to pay FQHCs at the encounter rates described in subsection (5) of this section.

(b) Each FQHC has the choice of receiving either its PPS rate, as determined under the method described in subsection (3) of this section, or a rate determined under a revised APM, as described in (c) of this subsection.

(c) The revised APM uses each FQHC's PPS rate for the current calendar year, increased by five percent.

(d) For all payments made for services provided during the period beginning April 7, 2011, and ending June 30, 2011, the agency (~~(will)~~) recoups from FQHCs any amount in excess of the encounter rate established in this section. This process is specified in emergency rules that took effect on October 29, 2011, (WSR 11-22-047) and February 25, 2012 (WSR 12-06-002).

(7) This subsection describes the encounter rates that the agency pays FQHCs for services provided on and after July 1, 2011. On January 12, 2012, CMS approved a SPA containing the methodology outlined in this section.

(a) Each FQHC has the choice of receiving either its PPS rate as determined under the method described in subsection (3) of this section, or a rate determined under a revised APM, as described in (b) of this subsection.

(b) The revised APM, known as APM-3, is as follows:

(i) For FQHCs that rebased their rate effective January 1, 2010, the revised APM is their allowed cost per visit during the cost report year increased by the cumulative percentage increase in the MEI between the cost report year and January 1, 2011.

(ii) For FQHCs that did not rebase their rate effective January 1, 2010, the revised APM is based on their PPS base rate from 2001 (or subsequent year for FQHCs receiving their initial FQHC designation after 2002) increased by the cumulative percentage increase in the IHS Global Insight index from the base year through calendar year 2008 and by the cumulative percentage increase in the MEI from calendar years 2009 through 2011. The rates were increased by the MEI effective January 1, 2012, and ~~((will be))~~ are increased by the MEI each January 1st thereafter.

(c) For all payments made for services provided during the period beginning July 1, 2011, and ending January 11, 2012, the agency ~~((will))~~ recoups from FQHCs any amount paid in excess of the encounter rate established in this section. This process is specified in emergency rules that took effect on October 29, 2011, (WSR 11-22-047) and February 25, 2012 (WSR 12-06-022).

(d) For FQHCs that choose to be paid under the revised APM, the agency ~~((will))~~ periodically rebases the encounter rates using the FQHC cost reports and other relevant data. Rebasing ~~((will be))~~ is done only for FQHCs that are reimbursed under the APM.

(e) The agency ~~((will))~~ ensures that the payments made under the APM are at least equal to the payments that would be made under the PPS.

(8) This subsection describes the payment methodology that the agency uses to pay participating FQHCs for services provided beginning July 1, 2017, and ending December 31, 2022.

(a) Each FQHC may receive payments under the APM described in subsection (7) of this section, or receive payments under the revised APM described in this subsection.

(b) The revised APM, known as APM-4, is as follows:

(i) The revised APM establishes a budget-neutral, baseline per member per month (PMPM) rate for each FQHC. The PMPM rate accounts for enhancement payments in accordance with the definition of enhancements in WAC 182-548-1100. For the purposes of this section, "budget-neutral" means the cost of the revised APM to the agency will not exceed what would have otherwise been spent not including the revised APM on a per member per year basis.

(ii) The agency pays the FQHC a PMPM payment each month for each managed care client assigned to them by an MCO.

(iii) The agency pays the FQHC a PMPM rate in addition to the amounts the MCO pays the FQHC. The agency may prospectively adjust the FQHC's PMPM rate for any of the following reasons:

(A) Quality and access metrics performance.

(B) FQHC encounter rate changes.

(iv) In accordance with 42 U.S.C. 1396a (bb) (5) (A), the agency performs an annual reconciliation.

(A) If the FQHC was underpaid, the agency pays the difference, and the PMPM rate may be subject to prospective adjustment under (b) (iii) of this subsection.

(B) If the FQHC was overpaid, the PMPM rate may be subject to prospective adjustment under (b) (iii) of this subsection.

[Statutory Authority: RCW 41.05.021, 41.05.160 and 42 U.S.C. 1396a (bb) (5) (A). WSR 20-24-083, § 182-548-1400, filed 11/25/20, effective 1/1/21. Statutory Authority: RCW 41.05.021 and 41.05.160. WSR 17-12-016, § 182-548-1400, filed 5/30/17, effective 7/1/17; WSR 15-11-008, § 182-548-1400, filed 5/7/15, effective 6/7/15; WSR 14-14-056, § 182-548-1400, filed 6/26/14, effective 8/1/14. Statutory Authority: RCW 41.05.021. WSR 12-16-060, § 182-548-1400, filed 7/30/12, effective 8/30/12. WSR 11-14-075, recodified as § 182-548-1400, filed 6/30/11, effective 7/1/11. Statutory Authority: RCW 74.08.090, BIPA of 2000 Section 702, sections 201 and 209 of 2009-2011 budget bill, and 42 U.S.C. 1396a(bb). WSR 10-09-002, § 388-548-1400, filed 4/7/10, effective 5/8/10.]

AMENDATORY SECTION (Amending WSR 20-24-083, filed 11/25/20, effective 1/1/21)

WAC 182-548-1450 Federally qualified health centers—General payment information. (1) The agency limits FQHC encounter((s)) rate reimbursement to one per client, per day except in the following circumstances:

(a) ~~((The visits occur with different health care professionals with different specialties))~~ There is a subsequent visit in the same cost center that requires separate evaluation and treatment on the same day for unrelated diagnoses; or

(b) There are separate visits ((with unrelated diagnoses.)) in different types of cost centers that occur with different health care professionals. (For example, a client with a separate medical and dental visit on the same day.)

(2) ~~((FQHC services and supplies incidental to the provider's services are included in the encounter rate payment.~~

~~(3) Fluoride treatment and sealants must be provided on the same day as an encounter-eligible service. If provided on another day, the rules for non-FQHC services in subsection (4) of this section apply.~~

~~(4) Payments for non-FQHC))~~ All services provided within the same cost center performed on the same day must be included in the same encounter, except for in the circumstance outlined in subsection (1)(a) of this section.

(3) Services and supplies incidental to an encounter are included in the encounter rate payment and must be billed on the same claim.

(4) FQHCs must provide services in a single encounter that are typically rendered in a single visit based on clinical guidance and standards of care.

(a) FQHCs must not split services into multiple encounters unless there is clinical justification. (For example, fluoride treatment must be provided on the same day as an encounter-eligible service.)

(b) Clinical justification must be based on medical necessity and documented in the client's record.

(5) Services provided in an FQHC that are not encounter-eligible are ((made)) paid on a fee-for-service basis ((using the agency's published)) according to agency rules, billing guides and fee schedules. ((Non-FQHC services are subject to the coverage guidelines and limitations listed in chapters 182-500 through 182-557 WAC.

~~(5) For clients enrolled with a managed care organization (MCO), covered FQHC services are paid for by that plan.)~~

(6) Managed care organization (MCO) contracted services provided in an FQHC for clients enrolled in an MCO are paid for by the MCO.

(7) For clients enrolled with an MCO, the agency pays each FQHC a supplemental payment in addition to the amounts paid by the MCO. The supplemental payments, called enhancements, are paid in amounts necessary to ensure compliance with 42 U.S.C. 1396a (bb) (5) (A).

(a) The FQHCs receive an enhancement payment each month for each managed care client assigned to them by an MCO.

(b) To ensure that the appropriate amounts are paid to each FQHC, the agency performs an annual reconciliation of the enhancement payments.

(i) For each FQHC, the agency compares the amount paid in enhancement payments to the amount determined by the following formula: ((Managed care encounters times encounter rate) less actual MCO payments for FQHC services.)

(Managed care encounters x encounter rate) - MCO payments for FQHC services

(ii) If the agency determines that the FQHC ((has been)) was overpaid, the agency recoups the appropriate amount. If the agency determines that the FQHC ((has been)) was underpaid, the agency pays the difference.

~~((7) Only clients enrolled in Title XIX (medicaid) or Title XXI (CHIP) are eligible for encounter or enhancement payments. The agency does not pay the encounter rate or the enhancement rate for clients in state-only medical programs.))~~ (iii) The agency may prospectively adjust the FQHC's monthly enhancement payments if the agency determines the FQHC has been overpaid or underpaid in the annual reconciliation.

(A) The agency uses the FQHC's most current reconciliation data, and any supplemental information provided by the FQHC to determine if any adjustment to the enhancement rate is necessary.

(B) If the agency determines a prospective adjustment to enhancement payments is necessary, the agency notifies the FQHC in writing at least 30 calendar days prior to the enhancement payment adjustment.

(8) The agency pays the encounter rate and the enhancement payments with respect to services provided to encounter-eligible clients. Services provided to clients who are enrolled in ((state-only)) medical programs that are ((considered)) paid only in state funds are not encounter-eligible; these claims are paid on a fee-for-service basis regardless of the type of service performed.

[Statutory Authority: RCW 41.05.021, 41.05.160 and 42 U.S.C. 1396a (bb) (5) (A). WSR 20-24-083, § 182-548-1450, filed 11/25/20, effective 1/1/21. Statutory Authority: RCW 41.05.021 and 41.05.160. WSR 17-12-016, § 182-548-1450, filed 5/30/17, effective 7/1/17.]

AMENDATORY SECTION (Amending WSR 15-05-023, filed 2/9/15, effective 3/12/15)

WAC 182-548-1500 Federally qualified health centers—Change in scope of service rate adjustment. In accordance with 42 U.S.C. 1396a (bb) (3) (B), the agency ((will)) adjusts its payment rate to a federal-

ly qualified health center (FQHC) to take into account any increase or decrease in the scope of the FQHC's services. The procedures and requirements for any such rate adjustment are described below.

(1) **Triggering events.**

(a) An FQHC may file a change in scope of services rate adjustment application with the agency on its own initiative only when ~~((~~+~~))~~ the FQHC satisfies the criteria described in (a) (i), (ii), and (iii) of this subsection.

(i) When the cost to the FQHC of providing covered health care services to eligible clients has increased or decreased due to one or more of the following triggering events:

(A) A change in the type of health care services the FQHC provides;

(B) A change in the intensity of health care services the FQHC provides. Intensity means the total quantity of labor and materials consumed by an individual client during an average encounter has increased;

(C) A change in the duration of health care services the FQHC provides. Duration means the length of an average encounter has increased;

(D) A change in the amount of health care services the FQHC provides in an average encounter;

(E) Any change comparable to (a) (i) (A) through (D) of this subsection in which the type, intensity, duration or amount of services has decreased and the cost of an average encounter has decreased ~~((~~+~~ and))~~ .

(ii) The cost change equals or exceeds:

(A) An increase of one and three-quarters percent in the prospective payment system (PPS) rate per encounter over one year as measured by comparing the cost per encounter to the then current PPS rate;

(B) A decrease of two and one-half percent in the PPS rate per encounter over one year as measured by comparing the cost per encounter to the then current PPS rate; or

(C) A cumulative increase or decrease of five percent in the PPS rate per encounter as compared to the current year's cost per encounter ~~((~~+~~ and))~~ .

(iii) The costs reported to the agency to support the proposed change in scope rate adjustment are reasonable under OMB *Circular A-122* or successor (the *Uniform Grants Guidance*) and other applicable state and federal law.

(b) At any time, the agency may instruct the FQHC to file a Medicaid cost report with a position statement ~~((~~of~~))~~ indicating whether the FQHC asserts that its PPS rate should be increased or decreased due to a change in the scope of services ~~((~~the FQHC "position statement"~~))~~ .

(i) The FQHC ~~((~~must~~))~~ files a completed cost report and position statement no later than ~~((~~ninety~~))~~ 90 calendar days after receiving the instruction from the agency ~~((~~to file same; provided, however,~~))~~ . If the FQHC has ~~((~~recently completed its fiscal year~~))~~ not received the annual audit report at the time of the agency's request ~~((~~but has not received its annual audit by the time of the request~~))~~, the FQHC ~~((~~may at its option wait and respond to the agency's request ninety days after the FQHC receives its annual audit or it may submit a cost report~~))~~ informs the agency, in writing, that it will submit one of the following alternatives:

(A) The cost report and position statement within 90 calendar days of receiving its annual audit report; or

(B) The cost report and position statement based on the prior year's audit.

(ii) The agency reviews the FQHC's cost report and position statement (~~(will be reviewed)~~) under the same criteria listed above for an application for a change in scope adjustment.

(iii) The agency will not request more than one change in scope in a calendar year.

(2) **Filing requirements.**

(a) The FQHC may apply for a prospective change in scope of service rate adjustment, a retrospective change in scope of service rate adjustment, or both, in a single application.

~~((i))~~ (b) Unless instructed to file an application by the agency, the FQHC may file no more than one change in scope of service application per calendar year; however, more than one type of change in scope may be included in a single application.

~~((ii))~~ (c) The FQHC (~~(must)~~) files for a change in scope of service rate adjustment (~~(no later than)~~) based on the following deadlines, whichever is later:

(i) Ninety calendar days after the end of the (~~(calendar)~~) FQHC's fiscal year (~~(in which)~~), demonstrating that the change in scope occurred as documented in the medicaid cost report.

(ii) Ninety calendar days after the FQHC (~~(believes the change in scope occurred or in which the FQHC)~~) learned, based on its annual audit, that the cost threshold in subsection (1)(a)(ii) of this section was met (~~(, whichever is later)~~) during the fiscal year.

~~((b))~~ (d) Prospective change in scope.

~~((i))~~ (i) A prospective change in scope of service rate adjustment application must state each triggering event listed in subsection (1)(a)(i) of this section that supports the FQHC's application.

(ii) A prospective change in scope of service rate adjustment application (~~(, the FQHC must submit projected costs sufficient to establish an interim rate. A prospective change is)~~) must be based on one of the following:

(A) A change the FQHC plans to implement in the future. The FQHC submits 12 months of projected data and costs sufficient to establish an interim rate; or

(B) A change which occurred in the FQHC's most recent fiscal year with less than 12 months of experience to support the change reflected in the medicaid cost report. The FQHC submits a combination of historical data and projected costs sufficient to establish an interim rate.

(iii) The interim rate adjustment (~~(will go)~~) goes into effect after the change takes effect.

~~((ii))~~ (iv) The interim rate is subject to the post change in scope review and rate adjustment process defined in subsection (5) of this section.

~~((iii))~~ (v) If the change in scope occurs (~~(fewer)~~) less than (~~(ninety)~~) 90 calendar days after the FQHC submitted a complete application to the agency, the interim rate (~~(must)~~) takes effect no later than (~~(ninety)~~) 90 calendar days after the complete application was submitted to the agency.

~~((iv))~~ (vi) If the change in scope occurs more than (~~(ninety)~~) 90 calendar days but (~~(fewer)~~) less than (~~(one hundred eighty)~~) 180 calendar days after the FQHC submitted a complete application to the agency, the interim rate takes effect when the change in scope occurs.

~~((v))~~ (vii) If the FQHC fails to implement a change in service identified in its prospective change in scope of service rate adjust-

ment application within ~~((one hundred eighty))~~ 180 calendar days, the application is void and the FQHC may resubmit the application to the agency, in ~~((which case))~~ such a circumstance, ~~((a-i))~~ (b) of this subsection does not apply.

~~((e))~~ (viii) If the change in scope is based on a triggering event that already occurred but is supported by less than 12 months of data in the filed cost report, the interim rate takes effect on the date the FQHC submitted the completed application to the agency.

(e) Retrospective change in scope.

(i) A retrospective change in scope of service rate adjustment application must state each ~~((qualifying))~~ triggering event listed in subsection (1)(a)(i) of this section that supports its application and include ~~((twelve))~~ 12 months of data documenting the cost change caused by the ~~((qualifying))~~ triggering event. A retrospective change in scope is a change that took place in the past and the FQHC is seeking to adjust its rate based on that change.

(ii) If approved, a retrospective rate adjustment takes effect on the date the FQHC ~~((filed the))~~ submitted a complete application ~~((with))~~ to the agency, as determined by the agency.

(3) Supporting documentation.

(a) To apply for a change in scope of service rate adjustment, the FQHC ~~((must include))~~ submits the following supporting documentation ~~((in the application))~~ to the agency in electronic format by email to fqhcrhc@hca.wa.gov:

(i) A narrative description of the proposed change in scope;

(ii) A description of each cost center on the cost report that was or will be affected by the change in scope;

(iii) The FQHC's most recent audited financial statements, if audit is required by federal law;

(iv) The implementation date for the proposed change in scope;

and

(v) Any additional documentation requested by the agency.

(b) A prospective change in scope of service rate adjustment application must also include the projected medicaid cost report ~~((or))~~ and the projected medicare cost report with supplemental schedules necessary to identify the medicaid cost per visit for the ~~((twelve-month))~~ 12-month period following implementation of the change in scope.

(c) A retrospective change in scope of service rate adjustment application must also include the medicaid cost report ~~((or))~~ and the medicare cost report with supplemental schedules necessary to identify the medicaid cost per visit and encounter data for ~~((twelve months or the fiscal year))~~ one of the following:

(i) The 12-month period following the implementation of the triggering event; or

(ii) The fiscal year following implementation of the proposed change in scope.

(4) Review of the application.

(a) Application processing.

(i) The agency ~~((must))~~ reviews the application for completeness, accuracy, and compliance with program rules.

(ii) Within ~~((sixty))~~ 60 calendar days of receiving the application, the agency ~~((must notify))~~ notifies the FQHC of any deficient documentation or request any additional information that is necessary to process the application. If the FQHC does not provide the agency with the documentation or information within 30 calendar days of the request, the agency may deny the application.

(iii) Within ~~((ninety))~~ 90 calendar days of receiving a complete application, including any additional documentation or information that the agency might request, the agency ~~((must))~~ sends the FQHC:

(A) A decision stating whether it will implement a PPS rate change; and

(B) A rate-setting statement if the rate change is implemented.

~~((Failure to act within ninety days will mean that the change is considered denied by the agency and))~~ The FQHC may appeal the decision on the application as provided for in ~~((subsection (6) of this section))~~ WAC 182-548-1650.

(b) Determining rate for change in scope.

(i) The agency ~~((must))~~ sets an interim rate for prospective changes in scope by adjusting the FQHC's existing rate by the projected average cost per encounter of any approved change. The agency ~~((will))~~ reviews the costs to determine if they are reasonable, and set a new interim rate based on the determined cost per encounter.

(ii) The agency ~~((must))~~ sets an adjusted encounter rate for retrospective changes in scope by adjusting the FQHC's existing rate by the documented average cost per encounter of the approved change. ~~((Projected costs per encounter may be used if there are insufficient historical data to establish the rate.))~~ The agency ~~((will))~~ reviews the costs to determine whether they are reasonable, and set a new rate based on the determined cost per encounter.

(c) If the FQHC is paid under an alternative payment methodology (APM), any change in scope of service rate adjustment ~~((requested by the FQHC will modify))~~ approved by the agency modifies the PPS rate in addition to the APM.

(d) The agency may delegate the duties related to application processing and rate setting to a third party. The agency retains final responsibility and authority for making decisions related to changes in scope.

(5) Post change in scope of services rate adjustment review.

(a) If the approved change in scope ~~((application))~~ rate adjustment was based on a retrospective change in scope application (i.e., based on a year or more of actual encounter data), the agency may conduct a post change in scope rate adjustment review.

(b) If the approved change in scope ~~((application was))~~ rate adjustment was based on a prospective change in scope application (i.e., based on less than a full year of actual encounter data), the FQHC ~~((must))~~ submits the following information to the agency within ~~((eighteen))~~ 18 months of the effective date of the rate adjustment:

(i) Medicaid cost report ~~((or))~~ and medicare cost report with supplemental schedules necessary to identify the medicaid cost per visit and encounter data for ~~((twelve))~~ 12 consecutive months of experience following implementation of the change in scope; ~~((and))~~

(ii) A narrative description of the request;

(iii) A description of each cost center on the cost report that was affected by the change in scope;

(iv) The FQHC's most recent audited financial statements, if audit is required by applicable law; and

(v) Any additional documentation requested by the agency.

(c) The agency ~~((will))~~ conducts the post change in scope review within ~~((ninety))~~ 90 calendar days of receiving the cost report and encounter data from the FQHC.

(d) If necessary, the agency ~~((will))~~ adjusts the encounter rate within ~~((ninety))~~ 90 calendar days to ensure that the rate reflects the reasonable cost of the change in scope of services.

(e) A rate adjustment based on a post change in scope review ~~((will))~~ takes effect on the date the agency issues its adjustment. The new rate ~~((will be))~~ is prospective.

(f) If the FQHC fails to submit the post change in scope cost report or related encounter data, the agency ~~((must))~~ provides written notice to the center or clinic ~~((of the deficiency))~~ within ~~((thirty))~~ 30 calendar days.

(g) If the FQHC fails to submit required documentation within five months of ~~((this deficiency notice))~~ the notice identified in (f) of this subsection, the agency may reinstate the prechange in scope encounter rate going forward from the date the interim rate was established. The agency may recoup any overpayment to the FQHC ~~((may be recouped by the agency))~~.

~~((6) Appeals. Appeals of agency action under this section are governed by WAC 182-502-0220, except that any rate change begins on the date the agency received the change in scope of services rate adjustment application.))~~

[Statutory Authority: RCW 41.05.021 and 41.05.160. WSR 15-05-023, § 182-548-1500, filed 2/9/15, effective 3/12/15. WSR 11-14-075, recodified as § 182-548-1500, filed 6/30/11, effective 7/1/11. Statutory Authority: RCW 74.08.090, BIPA of 2000 Section 702, sections 201 and 209 of 2009-2011 budget bill, and 42 U.S.C. 1396a(bb). WSR 10-09-002, § 388-548-1500, filed 4/7/10, effective 5/8/10.]

NEW SECTION

WAC 182-548-1600 Federally qualified health centers—Appeals related to overpayments. An overpayment assessment by the agency against an FQHC identified in the annual managed care reconciliation (see WAC 182-548-1450) may be appealed based on WAC 182-502-0230 and RCW 41.05A.170. Administrative hearing appeals are governed by chapter 34.05 RCW (Administrative Procedure Act) and chapter 182-526 WAC (HCA administrative hearing rules).

[]

NEW SECTION

WAC 182-548-1650 Federally qualified health centers—Appeals related to rate setting. (1) An FQHC provider has a right to an administrative appeal of agency action related to rate setting under this chapter based on the rules in this section.

(a) The rules in WAC 182-502-0220 do not apply to appeals of agency action related to rate setting under this chapter.

(b) Appeals related to rate setting under this section are not governed by the Administrative Procedure Act, chapter 34.05 RCW.

(c) Any rate change that the agency grants that is the result of fraudulent practices on the part of the FQHC, including as described under RCW 74.09.210, is exempt from the appeal provisions in this chapter.

(d) An FQHC who fails to submit requested information as outlined in this chapter will be determined to have abandoned their appeal.

(2) The first level of appeal.

(a) An FQHC provider who wants to contest an agency action concerning the reimbursement rate must file a written appeal with the agency. Written appeals must be sent to the address provided in the rate notification letter.

(b) The FQHC must file the appeal within 60 calendar days of the date of the rate notification letter from the agency, unless an extension has been granted.

(i) The agency may grant a time extension for the appeal period if the FQHC makes such a request before the expiration of the 60-day period.

(ii) The agency does not consider an appeal filed after the 60-day period unless an extension is granted by the agency.

(c) The appeal must include the following:

(i) A statement of the specific issue being appealed;

(ii) Supporting documentation; and

(iii) A request for the agency to recalculate the rate.

(d) When an FQHC appeals a portion of a rate, the agency may review all components of the reimbursement rate.

(e) To complete a review of the appeal, the agency may do one or both of the following:

(i) Request additional information;

(ii) Conduct an audit of the documentation provided.

(f) The agency issues a decision or requests additional information within 60 calendar days of receiving the rate appeal request. When the agency requests additional information:

(i) The FQHC has 45 calendar days from the date of the request to submit the additional information to the agency; and

(ii) The agency issues a decision within 30 calendar days of receipt of the additional information.

(g) Any rate increase or decrease resulting from an appeal is effective retroactively to the rate effective date in the notification letter. The exception is identified in (h) of this subsection.

(h) If an appeal is related to the denial of a change in scope rate adjustment application, any rate adjustment effective date is established by the following rules:

(i) For prospective change in scope, the effective date of the rate adjustment is established by WAC 182-548-1500 (2)(d);

(ii) For retrospective change in scope, the effective date of the rate adjustment is established by WAC 182-548-1500 (2)(e);

(iii) For a post change in scope of services, the effective date of the rate adjustment is established by WAC 182-548-1500 (5)(e).

(3) The second level of appeal.

(a) When an FQHC disagrees with a rate review decision from the first level of appeal, it may file a request along with supporting documentation for a dispute conference with the agency. For this section, "dispute conference" means an informal administrative appeal to resolve FQHC disagreements with an agency action not resolved at the first level of appeal.

(b) If an FQHC files a request for a dispute conference, it must submit the request to the agency within 30 calendar days after the date of the rate review decision.

(i) Any request for a dispute conference must be sent to the address indicated in the rate review decision.

(ii) The agency does not consider dispute conference requests submitted after the 30-day period for the first level decision.

(c) The agency conducts the dispute conference within 90 calendar days of receiving the request.

(d) The agency-director designee issues the final decision within 30 calendar days of the conference. Extensions of time for extenuating circumstances may be granted by the agency-director designee.

(e) Any rate increase or decrease resulting from a dispute conference decision is effective on the date specified in the dispute conference decision.

(f) The dispute conference is the final level of administrative appeal within the agency and precedes judicial action.

(4) The agency considers an FQHC who fails to attempt to resolve disputed rates as provided in this section has abandoned the dispute.

[]

OTS-4022.3

AMENDATORY SECTION (Amending WSR 20-02-070, filed 12/26/19, effective 1/26/20)

WAC 182-549-1100 Rural health clinics—Definitions. This section contains definitions of words and phrases that apply to this chapter. Unless defined in this chapter (~~(or)~~), the definitions found in chapter 182-500 WAC (~~(, the definitions found in the Webster's New World Dictionary)~~) apply.

"APM index" - The agency uses the alternative payment methodology (APM) (~~(is used)~~) to update APM encounter payment rates on an annual basis. The APM index is a measure of input price changes experienced by Washington's federally qualified health center (FQHC) and rural health clinic (RHC) providers. The index is derived from the federal medicare economic index (MEI).

"Base year" - The year that is used as the benchmark in measuring (~~(a clinic's)~~) an RHC's total reasonable costs for establishing base encounter rates.

"Cost center" - A category of service approved to be provided by the RHC under WAC 182-549-1200 and reported in the medicare cost report and supplemental documentation. The categories of services to be provided by the RHC may include medical and dental.

"Encounter" - A face-to-face or telemedicine (including audio-only telemedicine) visit between (~~(a client and a qualified RHC provider (e.g., a physician, dentist, physician's assistant, or advanced registered nurse practitioner))~~) an encounter-eligible client and an RHC provider who exercises independent judgment when providing services that qualify for (~~(an)~~) encounter rate reimbursement.

"Encounter-eligible client" - A client who receives benefits under Title XIX (medicaid) or Title XXI (CHIP).

"Encounter rate" - A cost-based, facility-specific rate for covered RHC services (~~(, paid to a rural health clinic for each valid encounter it bills)~~).

"Enhancements (also called managed care enhancements or supplemental payments)" - A monthly amount (~~(paid by)~~) the agency pays to RHCs through a managed care organization (MCO) that has contracted with the RHC to provide services to clients enrolled with the MCO. The enhancement is in addition to the negotiated payment that RHCs receive from the MCO. RHCs participating in the payment method described in WAC 182-549-1450 (~~((+5))~~) (7)(b) do not receive enhancements.

"Fee-for-service" - A payment method the agency uses to pay providers for covered medical services provided to (~~(clients enrolled in the Title XIX (medicaid) program or the Title XXI (CHIP) program, except those)~~) Washington apple health clients, which excludes services provided ((under)) by the agency's ((prepaid)) contracted managed care organizations ((or those)) and services that qualify for an encounter payment.

"Interim rate" - The rate (~~(established by)~~) the agency estab-
lishes to pay (~~(a rural health clinic))~~ an RHC for covered RHC services prior to the establishment of a permanent rate for that (~~((family))~~) RHC.

"Medicare cost report" - The cost report is a statement of costs and provider utilization that occurred during the time period covered by the cost report. RHCs must complete and submit a report annually to medicare.

"Medicare economic index (MEI)" - An index published in the Federal Register used in the calculation of changes to determine allowed charges for physician services. The agency adjusts RHC encounter rates and enhancement rates by the MEI each year on January 1st.

"Mobile unit" - The objects, equipment, and supplies necessary for provision of the services furnished directly by the RHC are housed in a mobile structure.

"Permanent unit" - The objects, equipment, and supplies necessary for the provision of the services furnished directly by the RHC are housed in a permanent structure.

"Rebasing" - The process of recalculating encounter rates using actual cost report data.

"Rural area" - An area that is not delineated as an urbanized area by the U.S. Census Bureau.

"Rural health clinic (RHC)" - A clinic, as defined in 42 C.F.R. 405.2401(b), that is primarily engaged in providing RHC services and is:

- Located in a rural area designated as a shortage area as defined under 42 C.F.R. 491.2;
- Certified by medicare as an RHC in accordance with applicable federal requirements; and
- Not a rehabilitation agency or a facility primarily for the care and treatment of mental diseases.

"Rural health clinic (RHC) services" - Outpatient or ambulatory care of the nature typically provided in a physician's office or outpatient clinic or similar setting, including specified types of diagnostic examination, laboratory services, and emergency treatments. The specific list of services which must be made available by the clinic can be found under 42 C.F.R. Part 491.9.

[Statutory Authority: RCW 41.05.021 and 41.05.160. WSR 20-02-070, § 182-549-1100, filed 12/26/19, effective 1/26/20; WSR 18-10-058, § 182-549-1100, filed 4/27/18, effective 5/28/18. Statutory Authority: RCW 41.05.021, 41.05.160, 2017 3rd sp.s. c 1 § 213(1)(11). WSR 17-22-070, § 182-549-1100, filed 10/27/17, effective 1/1/18. Statutory

Authority: RCW 41.05.021 and 41.05.160. WSR 15-11-008, § 182-549-1100, filed 5/7/15, effective 6/7/15. WSR 11-14-075, recodified as § 182-549-1100, filed 6/30/11, effective 7/1/11. Statutory Authority: RCW 74.08.090, 74.09.510, 74.09.522, 42 U.S.C. 1396a(bb), 42 C.F.R. 405.2472, and 42 C.F.R. 491. WSR 10-09-030, § 388-549-1100, filed 4/13/10, effective 5/14/10. Statutory Authority: RCW 74.08.090, 74.09.510, 74.09.522, 42 C.F.R. 405.2472, 42 C.F.R. 491. WSR 08-05-011, § 388-549-1100, filed 2/7/08, effective 3/9/08.]

AMENDATORY SECTION (Amending WSR 20-02-070, filed 12/26/19, effective 1/26/20)

WAC 182-549-1200 Rural health clinics—Enrollment. (1) To participate in the Title XIX (medicaid) program or the Title XXI (CHIP) program and receive payment for services, a rural health clinic (RHC) must:

- (a) Receive RHC certification for participation in the Title XVIII (medicare) program according to 42 C.F.R. 491;
 - (b) Sign a core provider agreement with the medicaid agency;
 - (c) Comply with the clinical laboratory improvement amendments (CLIA) of 1988 testing for all laboratory sites per 42 C.F.R. Part 493; and
 - (d) Operate in accordance with applicable federal, state, and local laws.
- (2) An RHC may be a permanent or mobile unit. If an entity owns clinics in multiple locations, each individual site must be certified by the agency in order to receive reimbursement from the agency as an RHC.
- (3) The agency uses one of two timeliness standards for determining the effective date of a medicaid-certified RHC.
- (a) The agency uses medicare's effective date if the RHC returns a properly completed core provider agreement and a properly completed RHC enrollment packet within ((sixty)) 60 calendar days from the date of ((medicare's letter notifying the clinic)) CMS's written notification to the RHC of the medicare certification.
 - (b) The agency uses the date the medicare certification letter is received by the agency if the RHC returns either the properly completed core provider agreement ((and)) or properly completed RHC enrollment packet after ((sixty)) 60 calendar days of the date of medicare's letter notifying the clinic of the medicare certification.

[Statutory Authority: RCW 41.05.021 and 41.05.160. WSR 20-02-070, § 182-549-1200, filed 12/26/19, effective 1/26/20; WSR 15-11-008, § 182-549-1200, filed 5/7/15, effective 6/7/15. WSR 11-14-075, recodified as § 182-549-1200, filed 6/30/11, effective 7/1/11. Statutory Authority: RCW 74.08.090, 74.09.510, 74.09.522, 42 C.F.R. 405.2472, 42 C.F.R. 491. WSR 08-05-011, § 388-549-1200, filed 2/7/08, effective 3/9/08.]

AMENDATORY SECTION (Amending WSR 20-02-070, filed 12/26/19, effective 1/26/20)

WAC 182-549-1300 Rural health clinics—Services. (1) Rural health clinic (RHC) services are defined under 42 C.F.R. 440.20(b).
 (2) The medicaid agency pays for RHC services when they are:
 (a) Within the scope of ((a)) an encounter-eligible client's benefit package. See WAC 182-501-0060; and
 (b) Medically necessary as defined in WAC 182-500-0070.
 (3) RHC services may be provided by any of the following individuals in accordance with 42 C.F.R. 405.2401, 491.7, and 491.8:
 (a) Physicians;
 (b) Physician assistants (PA);
 (c) Nurse practitioners (NP);
 (d) Nurse midwives or other specialized nurse practitioners;
 (e) Certified nurse midwives;
 (f) Registered nurses (RN) or licensed practical nurses (LPN);
 (g) Psychologists or clinical social workers; and
 (h) Dental services specified in 42 C.F.R. Sec. 440.100.

[Statutory Authority: RCW 41.05.021 and 41.05.160. WSR 20-02-070, § 182-549-1300, filed 12/26/19, effective 1/26/20; WSR 15-11-008, § 182-549-1300, filed 5/7/15, effective 6/7/15. WSR 11-14-075, recodified as § 182-549-1300, filed 6/30/11, effective 7/1/11. Statutory Authority: RCW 74.08.090, 74.09.510, 74.09.522, 42 C.F.R. 405.2472, 42 C.F.R. 491. WSR 08-05-011, § 388-549-1300, filed 2/7/08, effective 3/9/08.]

AMENDATORY SECTION (Amending WSR 20-24-083, filed 11/25/20, effective 1/1/21)

WAC 182-549-1400 Rural health clinics—Reimbursement and limitations. (1) For services provided during the period beginning January 1, 2001, and ending December 31, 2008, the medicaid agency's payment methodology for rural health clinics (RHC) was a prospective payment system (PPS) as authorized by 42 U.S.C. 1396a (bb) (2) and (3).
 (2) For services provided beginning January 1, 2009, RHCs have the choice to be reimbursed under the PPS or be reimbursed under an alternative payment methodology (APM), as authorized by 42 U.S.C. 1396a (bb) (6). As required by 42 U.S.C. 1396a (bb) (6), payments made under the APM are at least as much as payments that would have been made under the PPS.
 (3) The agency calculates RHC PPS encounter rates for RHC core services as follows:
 (a) Until an RHC submits its first audited or as filed medicare cost report to the agency, the agency pays the RHC an average encounter rate of other similar RHCs within the state, otherwise known as an interim rate. Similar RHCs are defined as either all hospital based or all free-standing RHCs((~~+~~)).
 (b) Upon ((~~submission of the RHC's first audited medicare cost report,~~)) the RHC's request to the agency, which must include the submission of the RHC's first as filed or audited medicare cost report, the agency calculates the RHC's PPS rates for RHC core services. The agency sets each RHC's encounter rates ((at one hundred)) by dividing

100 percent of ((its)) the RHC's costs ((as defined in the cost report)) divided by the total number of RHC encounters ((the RHC has provided during the time period covered in the audited)) reported in the submitted cost report. The encounter rate is effective on the date the agency receives the submitted medicare cost report from the RHC.

(c) RHCs receive this rate for the remainder of the calendar year during which the ((audited)) submitted medicare cost report became available to the agency. The agency then ((increases)) adjusts the encounter rate each January 1st by the percent change in the medicare economic index (MEI).

(4) For RHCs in existence during calendar years 1999 and 2000, the agency sets the encounter rates prospectively using a weighted average of ((one hundred)) 100 percent of the RHC's total reasonable costs for calendar years 1999 and 2000 and adjusted for any increase or decrease in the scope of services furnished during the calendar year 2001 to establish a base encounter rate.

(a) The agency adjusts PPS base encounter rates to account for an increase or decrease in the scope of services provided during calendar year 2001 in accordance with WAC 182-549-1500.

(b) The agency determines PPS base encounter rates ((are determined)) using medicare's audited cost reports, and each year's rate is weighted by the total reported encounters. The agency does not apply a capped amount to these base encounter rates. The formula used to calculate base encounter rates is as follows:

$$\text{Specific RHC Base Encounter Rate} = \frac{(\text{Year 1999 Rate} \times \text{Year 1999 Encounters}) + (\text{Year 2000 Rate} \times \text{Year 2000 Encounters})}{(\text{Year 1999 Encounters} + \text{Year 2000 Encounters}) \text{ for each RHC}}$$

(c) Beginning in calendar year 2002 and any year thereafter, encounter rates are ((increased)) adjusted by the MEI and adjusted for any increase or decrease in the RHC's scope of services.

(5) The agency calculated RHC's APM encounter rates for services provided during the period beginning January 1, 2009, and ending April 6, 2011, as follows:

(a) The APM used the RHC base encounter rates as described in subsection (4)(b) of this section.

(b) Base rates were increased by each annual percentage, from calendar years 2002 through 2009, of the IHS Global Insight index, also called the APM index.

(c) The result was the year 2009 APM rates for each RHC that chose to be reimbursed under the APM.

(6) This subsection describes the encounter rates that the agency paid RHCs for services provided during the period beginning April 7, 2011, and ending June 30, 2011. On January 12, 2012, the federal Centers for Medicare and Medicaid Services (CMS) approved a state plan amendment (SPA) containing the methodology outlined in this section.

(a) During the period that CMS approval of the SPA was pending, the agency continued to pay RHCs at the encounter rate described in subsection (5) of this section.

(b) Each RHC had the choice of receiving either its PPS rate, as determined under the method described in subsection (3) of this section, or a rate determined under a revised APM, as described in (c) of this subsection.

(c) The revised APM used each RHC's PPS rate for the current calendar year, increased by five percent.

(d) For all payments made for services provided during the period beginning April 7, 2011, and ending June 30, 2011, the agency recouped

from RHCs any amount paid in excess of the encounter rate established in this section. This process was specified in emergency rules that took effect on October 29, 2011, (WSR 11-22-047) and February 25, 2012 (WSR 12-06-002).

(7) This subsection describes the encounter rate that the agency pays RHCs for services provided on and after July 1, 2011. On January 12, 2012, CMS approved a SPA containing the methodology outlined in this section.

(a) Each RHC has the choice of receiving either its PPS rate, as determined under the method described in subsection (3) of this section, or a rate determined under a revised APM, as described in (b) of this subsection.

(b) The revised APM, known as APM-3, is as follows:

(i) For RHCs that rebased their rate effective January 1, 2010, the revised APM is their allowed cost per visit during the cost report year increased by the cumulative percentage increase in the MEI between the cost report year and January 1, 2011.

(ii) For RHCs that did not rebase their rate effective January 1, 2010, the revised APM is based on their PPS base rate from 2001 (or subsequent year for RHCs receiving their initial RHC designation after 2002) increased by the cumulative percentage increase in the IHS Global Insight index from the base year through calendar year 2008 and the cumulative increase in the MEI from calendar years 2009 through 2011. The rates are increased by the MEI effective January 1, 2012, and each January 1st thereafter.

(c) For all payments made for services provided during the period beginning July 1, 2011, and ending January 11, 2012, the agency recouped from RHCs any amount paid in excess of the encounter rate established in this section. This process was specified in emergency rules that took effect on October 29, 2011, (WSR 11-22-047) and February 25, 2012 (WSR 12-06-002).

(d) For RHCs that choose to be paid under the revised APM, the agency periodically rebases the encounter rates using the RHC cost reports and other relevant data. Rebasing is done only for RHCs that are reimbursed under the APM.

(e) The agency makes sure that the payments made under the APM are at least equal to the payments that would be made under the PPS.

(8) This subsection describes the payment methodology that the agency uses to pay participating RHCs for services provided beginning July 1, 2017, and ending December 31, 2022.

(a) Each RHC may receive payments under the APM described in subsection (7) of this section, or receive payments under the revised APM described in this subsection.

(b) The revised APM, known as APM-4, is as follows:

(i) The revised APM establishes a budget-neutral, baseline per member per month (PMPM) rate for each RHC. The PMPM rate (~~will~~) accounts for enhancement payments in accordance with the definition of enhancements in WAC 182-548-1100. For the purposes of this section, "budget-neutral" means the cost of the revised APM to the agency will not exceed what would have otherwise been spent not including the revised APM on a per member per year basis.

(ii) The agency pays the RHC a PMPM payment each month for each managed care client assigned to them by an MCO.

(iii) The agency pays the RHC a PMPM payment each month in addition to the amounts the MCO pays the RHC.

(iv) The agency may prospectively adjust the RHC's PMPM rate for any of the following reasons:

(A) Quality and access metrics performance.

(B) RHC encounter rate changes.

(v) In accordance with 42 U.S.C. 1396a (bb) (5) (A), the agency performs an annual reconciliation.

(A) If the RHC was underpaid, the agency pays the difference, and the PMPM rate may be subject to prospective adjustment under (b) (iv) of this subsection.

(B) If the RHC was overpaid, the PMPM rate may be subject to prospective adjustment under (b) (iv) of this subsection.

[Statutory Authority: RCW 41.05.021, 41.05.160 and 42 U.S.C. 1396a (bb) (5) (A). WSR 20-24-083, § 182-549-1400, filed 11/25/20, effective 1/1/21. Statutory Authority: RCW 41.05.021 and 41.05.160. WSR 20-02-070, § 182-549-1400, filed 12/26/19, effective 1/26/20; WSR 17-12-016, § 182-549-1400, filed 5/30/17, effective 7/1/17; WSR 15-11-008, § 182-549-1400, filed 5/7/15, effective 6/7/15. Statutory Authority: RCW 41.05.021. WSR 12-16-060, § 182-549-1400, filed 7/30/12, effective 8/30/12. WSR 11-14-075, recodified as § 182-549-1400, filed 6/30/11, effective 7/1/11. Statutory Authority: RCW 74.08.090, 74.09.510, 74.09.522, 42 U.S.C. 1396a(bb), 42 C.F.R. 405.2472, and 42 C.F.R. 491. WSR 10-09-030, § 388-549-1400, filed 4/13/10, effective 5/14/10. Statutory Authority: RCW 74.08.090, 74.09.510, 74.09.522, 42 C.F.R. 405.2472, 42 C.F.R. 491. WSR 08-05-011, § 388-549-1400, filed 2/7/08, effective 3/9/08.]

AMENDATORY SECTION (Amending WSR 20-24-083, filed 11/25/20, effective 1/1/21)

WAC 182-549-1450 Rural health clinics—General payment information. (1) The medicaid agency (~~((pays for one encounter,))~~) limits RHC encounter rate reimbursement to one per client, per day except in the following circumstances:

(a) (~~((The visits occur with different health care professionals with different specialties))~~) There is a subsequent visit in the same cost center that requires separate evaluation and treatment on the same day for unrelated diagnoses; or

(b) There are separate visits (~~((with unrelated diagnoses.~~

~~(2) Rural health clinic (RHC) services and supplies incidental to the provider's services are included in the encounter rate payment.~~

~~(3) The agency pays for non-RHC services provided in an RHC on a fee-for-service basis using the agency's published fee schedules. Non-RHC services are subject to the coverage guidelines and limitations listed in chapters 182-500 through 182-557 WAC.~~

~~(4) For clients enrolled with a managed care organization (MCO), that MCO pays for covered RHC services.~~

~~(5))~~ in different types of cost centers that occur with different health care professionals. (For example, a client with a separate medical and dental visit on the same day.)

(2) All services provided within the same cost center performed on the same day must be included in the same encounter, except for in the circumstances outlined in subsection (1) (a) of this section.

(3) Services and supplies incidental to an encounter are included in the encounter rate payment and must be billed on the same claim.

(4) RHCs must provide services in a single encounter that are typically rendered in a single visit based on clinical guidance and standards of care.

(a) RHCs must not split services into multiple encounters unless there is clinical justification. (For example, fluoride treatment must be provided on the same day as an encounter-eligible service.)

(b) Clinical justification must be based on medical necessity and documented in the client's record.

(5) Services provided in an RHC that are not encounter-eligible are paid on a fee-for-service basis. These services are paid according to agency rules, billing guides and fee schedules.

(6) Managed care organization (MCO) contracted services provided in an RHC for clients enrolled in an MCO are paid for by the MCO.

(7) For clients enrolled with MCOs, the RHC receives ~~((an))~~ encounter rate reimbursement using either the method described in (a) or (b) of this subsection.

(a) RHCs receive an enhancement payment in addition to the MCO's negotiated payment. The agency makes enhancement payments in amounts necessary to ~~((make sure))~~ ensure that the RHC receives the full encounter rate to comply with 42 U.S.C. 1396a (bb) (5) (A).

(i) The RHCs receive a monthly enhancement payment for each managed care client assigned to them by an MCO.

(ii) To ~~((make sure))~~ ensure that the appropriate amounts are paid to each RHC ~~((receives the appropriate amounts))~~, the agency performs an annual reconciliation of the enhancement payments.

(A) For each RHC, the agency compares the amount paid in enhancement payments to the amount determined by the following formula: ~~((Managed care encounters times encounter rate) less actual MCO payments for RHC services.)~~

(Managed care encounters x encounter rate) - MCO payments for RHC services.

(B) If the agency determines that the RHC ~~((has been))~~ was overpaid, the agency recoups the appropriate amount. If the agency determines that the RHC ~~((has been))~~ was underpaid, the agency pays the difference.

(C) The agency may prospectively adjust the RHC's monthly enhancement payments if the agency determines the RHC has been overpaid or underpaid in the annual reconciliation.

(D) The agency uses the RHC's most current reconciliation data, and any supplemental information provided by the RHC to determine if any adjustment to the enhancement rate is necessary.

(E) If the agency determines a prospective adjustment to enhancement payments is necessary, the agency notifies the RHC in writing at least 30 calendar days prior to the enhancement payment adjustment.

(F) For dates of service on and after January 1, 2018, reconciliations are conducted in the calendar year following the calendar year for which the enhancements were paid. Reconciliations are conducted by the agency or the clinic with final review and approval by the agency. The process of settling over or under payments may extend beyond the calendar year in which the reconciliations were conducted.

(b) Effective January 1, 2018, instead of distributing monthly enhancement payments to the RHCs, MCOs pay the full encounter rate directly to participating clinics for encounter-eligible services.

(i) RHC participation ~~((in this option))~~ is voluntary. The RHC ~~((must notify))~~ notifies the agency in writing whether it will partic-

ipate or not by no later than November 1st prior to the year of participation.

(ii) The agency performs a reconciliation or claim review with the MCO as outlined in the MCO contract. Reconciliations or claim reviews make sure appropriate amounts are paid to each RHC and that MCOs are not put at risk for, or have any right to, the enhancement portion of the claim. If an MCO has been overpaid, the agency recoups the appropriate amount. If an MCO has been underpaid, the agency pays the difference.

(iii) RHCs participating in the revised alternative payment method (APM) as described in WAC 182-549-1400(8) are not eligible to receive encounter payments directly from MCOs under this section.

~~((6) Only those services provided to clients enrolled in the Title XIX (medicaid) program or the Title XXI (CHIP) program are eligible for encounter or enhancement payments. The agency does not pay the encounter rate or the enhancement rate for services provided to clients in state-only medical programs.))~~ (8) The agency pays the encounter rate and the enhancement payments with respect to services provided to encounter-eligible clients. Services provided to clients ((in state-only)) who are enrolled in medical programs that are paid only in state funds are not encounter-eligible; these claims are ((considered)) paid on a fee-for-service basis, regardless of the type of service performed.

[Statutory Authority: RCW 41.05.021, 41.05.160; 42 U.S.C. 1396a (bb) (5) (A). WSR 20-24-083, § 182-549-1450, filed 11/25/20, effective 1/1/21. Statutory Authority: RCW 41.05.021 and 41.05.160. WSR 20-02-070, § 182-549-1450, filed 12/26/19, effective 1/26/20. Statutory Authority: RCW 41.05.021, 41.05.160, 2017 3rd sp.s. c 1 § 213(1)(11). WSR 17-22-070, § 182-549-1450, filed 10/27/17, effective 1/1/18. Statutory Authority: RCW 41.05.021 and 41.05.160. WSR 17-12-016, § 182-549-1450, filed 5/30/17, effective 7/1/17.]

AMENDATORY SECTION (Amending WSR 20-02-070, filed 12/26/19, effective 1/26/20)

WAC 182-549-1500 Rural health clinics—Change in scope of service rate adjustment. In accordance with 42 U.S.C. 1396a (bb) (3) (B), the agency adjusts its payment rate to a rural health clinic (RHC) to take into account any increase or decrease in the scope of the RHC's services. The procedures and requirements for any such rate adjustment are described below.

(1) **Triggering events.**

(a) An RHC may file a change in scope of services rate adjustment application with the agency on its own initiative only when ~~((÷))~~ the RHC satisfies the criteria described in (a) (i), (ii), and (iii) of this subsection.

(i) When the cost to the RHC of providing covered health care services to eligible clients has increased or decreased due to one or more of the following triggering events:

(A) A change in the type of health care services the RHC provides;

(B) A change in the intensity of health care services the RHC provides. Intensity means the total quantity of labor and materials

consumed by an individual client during an average encounter has increased;

(C) A change in the duration of health care services the RHC provides. Duration means the length of an average encounter has increased;

(D) A change in the amount of health care services the RHC provides in an average encounter;

(E) Any change comparable to (a) (i) (A) through (D) of this subsection in which the type, intensity, duration or amount of services has decreased and the cost of an average encounter has decreased (~~and~~).

(ii) The cost change equals or exceeds:

(A) An increase of one and three-quarters percent in the prospective payment system (PPS) rate per encounter over one year as measured by comparing the cost per encounter to the then current PPS rate;

(B) A decrease of two and one-half percent in the PPS rate per encounter over one year as measured by comparing the cost per encounter to the then current PPS rate; or

(C) A cumulative increase or decrease of five percent in the PPS rate per encounter as compared to the current year's cost per encounter (~~and~~).

(iii) The costs reported to the agency to support the proposed change in scope rate adjustment are reasonable under state and federal law.

(b) At any time, the agency may instruct the RHC to file a medicare cost report with a position statement (~~of~~) indicating whether the RHC asserts that its PPS rate should be increased or decreased due to a change in the scope of services (~~(the RHC "position statement")~~).

(i) The RHC (~~must~~) files a completed cost report and position statement no later than (~~ninety~~) 90 calendar days after receiving the instruction from the agency to file an application;

(ii) The agency reviews the RHC's cost report and position statement under the same criteria listed above for an application for a change in scope adjustment;

(iii) The agency (~~does~~) will not request more than one change in scope in a calendar year.

(2) **Filing requirements.**

(a) The RHC may apply for a prospective change in scope of service rate adjustment, a retrospective change in scope of service rate adjustment, or both, in a single application.

(~~(i)~~) (b) Unless instructed to file an application by the agency, the RHC may file no more than one change in scope of service application per calendar year; however, more than one type of change in scope may be included in a single application.

(~~(ii)~~) (c) The RHC (~~must~~) files for a change in scope of service rate adjustment (~~(no later than)~~) based on the following deadlines, whichever is later:

(i) Ninety calendar days after the end of the (~~calendar year in which the RHC believes the change in scope occurred or in which~~) RHC's fiscal year, demonstrating that the change in scope occurred.

(ii) Ninety calendar days after the RHC learned (~~that~~) the cost threshold in subsection (1) (a) (ii) of this section was met (~~(, whichever is later)~~).

(~~(b)~~) (d) Prospective change in scope.

(i) (~~To file~~) A prospective change in scope of service rate adjustment application (~~(, the RHC must submit projected costs sufficient~~

~~to establish an interim rate. A prospective change is))~~ states each triggering event listed in subsection (1)(a)(i) of this section that supports the RHC's application.

(ii) A prospective change in scope of service rate adjustment application must be based on one of the following:

(A) A change the RHC plans to implement in the future. The RHC submits 12 months of projected data and costs sufficient to establish an interim rate; or

(B) A change with less than 12 months of experience to support the change reflected in the medicare cost report. The RHC submits a combination of historical data and projected costs sufficient to establish an interim rate.

(iii) The interim rate adjustment goes into effect after the change takes effect.

~~((iii))~~ (iv) The interim rate is subject to the post change in scope review and rate adjustment process defined in subsection (5) of this section.

~~((iii))~~ (v) If the change in scope occurs ((fewer)) less than ((ninety)) 90 calendar days after the RHC submitted a complete application to the agency, the interim rate ((must)) takes effect no later than ((ninety)) 90 calendar days after the complete application was submitted to the agency.

~~((iv))~~ (vi) If the change in scope occurs more than ((ninety)) 90 calendar days but ((fewer)) less than ((one hundred eighty)) 180 calendar days after the RHC submitted a complete application to the agency, the interim rate takes effect when the change in scope occurs.

~~((v))~~ (vii) If the RHC fails to implement a change in service identified in its prospective change in scope of service rate adjustment application within ((one hundred eighty)) 180 calendar days, the application is void and the RHC may resubmit the application to the agency, in ((which case)) such a circumstance, ((a-i)) (b) of this subsection does not apply.

~~((e))~~ (viii) If the change in scope is based on a triggering event that already occurred but is supported by less than 12 months of data in the filed cost report, the interim rate takes effect on the date the RHC submitted the completed application to the agency.

(e) Retrospective change in scope.

(i) A retrospective change in scope of service rate adjustment application ((must)) states each ((qualifying)) triggering event listed in subsection (1)(a)(i) of this section that supports its application and include ((twelve)) 12 months of data documenting the cost change caused by the ((qualifying)) triggering event. A retrospective change in scope is a change that took place in the past and the RHC is seeking to adjust its rate based on that change.

(ii) If approved, a retrospective rate adjustment takes effect on the date the RHC ((filed the)) submitted a complete application ((with)) to the agency, as determined by the agency.

(3) Supporting documentation.

(a) To apply for a change in scope of service rate adjustment, the RHC ((must include)) submits the following supporting documentation ((in the application)) to the agency in electronic format by email to fgchrhc@hca.wa.gov:

(i) A narrative description of the proposed change in scope;

(ii) A description of each cost center on the cost report that was or will be affected by the change in scope;

(iii) The RHC's most recent audited financial statements, if audit is required by federal law;

(iv) The implementation date for the proposed change in scope;
and

(v) Any additional documentation requested by the agency.

(b) A prospective change in scope of service rate adjustment application must also include ((a)) the projected medicare cost report with supplemental schedules necessary to identify the medicaid cost per visit for the (~~twelve-month~~) 12-month period following implementation of the change in scope.

(c) A retrospective change in scope of service rate adjustment application must also include the medicare cost report with supplemental schedules necessary to identify the medicaid cost per visit and encounter data for (~~twelve months or~~) one of the following:

(i) The 12-month period following the implementation of the triggering event; or

(ii) The fiscal year following implementation of the proposed change in scope.

(4) **Review of the application.**

(a) Application processing.

(i) The agency reviews the application for completeness, accuracy, and compliance with program rules.

(ii) Within (~~sixty~~) 60 days of receiving the application, the agency notifies the RHC of any deficient documentation or requests any additional information that is necessary to process the application. If the RHC does not provide the agency with the documentation or information requested within 30 calendar days of the request, the agency may deny the application.

(iii) Within (~~ninety~~) 90 calendar days of receiving a complete application, including any additional documentation or information that the agency might request, the agency sends the RHC:

(A) A decision stating whether it will implement a PPS rate change; and

(B) A rate-setting statement if the rate change is implemented.

(iv) (~~Failure to act within ninety days means that the change is considered denied by the agency and~~) The RHC may appeal the decision on the application as provided for in ((subsection (6) of this section) WAC 182-549-1650.

(b) Determining rate for change in scope.

(i) The agency sets an interim rate for prospective changes in scope by adjusting the RHC's existing rate by the projected average cost per encounter of any approved change. The agency reviews the costs to determine if they are reasonable, and sets a new interim rate based on the determined cost per encounter.

(ii) The agency sets an adjusted encounter rate for retrospective changes in scope by adjusting the RHC's existing rate by the documented average cost per encounter of the approved change. (~~Projected costs per encounter may be used if there are insufficient historical data to establish the rate.~~) The agency reviews the costs to determine whether they are reasonable, and sets a new rate based on the determined cost per encounter.

(c) If the RHC is paid under an alternative payment methodology (APM), any change in scope of service rate adjustment approved by the agency modifies the PPS rate in addition to the APM.

(d) The agency may delegate the duties related to application processing and rate setting to a third party. The agency retains final responsibility and authority for making decisions related to changes in scope.

(5) **Post change in scope of services rate adjustment review.**

(a) If the approved change in scope ((application)) rate adjustment was based on a retrospective change in scope application (i.e., based on a year or more of actual encounter data), the agency may conduct a post change in scope rate adjustment review.

(b) If the approved change in scope ((application)) rate adjustment was based on a prospective change in scope application (i.e., less than a full year of actual encounter data), the RHC ~~((must))~~ submits the following information to the agency within ~~((eighteen))~~ 18 months of the effective date of the rate adjustment:

(i) Medicare cost report with supplemental schedules necessary to identify the medicaid cost per visit and encounter data for ~~((twelve))~~ 12 consecutive months of experience following implementation of the change in scope; ~~((and))~~

(ii) A narrative description of the request;

(iii) A description of each cost center on the cost report that was affected by the change in scope;

(iv) The RHC's most recent audited financial statements, if audit is required by applicable law; and

(v) Any additional documentation requested by the agency.

(c) The agency conducts the post change in scope review within ~~((ninety))~~ 90 calendar days of receiving the cost report and encounter data from the RHC.

(d) If necessary, the agency adjusts the encounter rate within ~~((ninety))~~ 90 calendar days to make sure that the rate reflects the reasonable cost of the change in scope of services.

(e) A rate adjustment based on a post change in scope review takes effect on the date the agency issues its adjustment. The new rate is prospective.

(f) If the RHC fails to submit the post change in scope cost report or related encounter data, the agency provides written notice to the clinic ~~((of the deficiency))~~ within ~~((thirty))~~ 30 calendar days.

(g) If the RHC fails to submit required documentation within five months of ~~((this deficiency))~~ the notice identified in (f) of this subsection, the agency may reinstate the prechange in scope encounter rate going forward from the date the interim rate was established. The agency may recoup any overpayment to the RHC.

~~((6) Appeals. Appeals of agency action under this section are governed by WAC 182-502-0220, except that any rate change begins on the date the agency received the change in scope of services rate adjustment application.))~~

[Statutory Authority: RCW 41.05.021 and 41.05.160. WSR 20-02-070, § 182-549-1500, filed 12/26/19, effective 1/26/20; WSR 15-05-020, § 182-549-1500, filed 2/9/15, effective 3/12/15. WSR 11-14-075, recodified as § 182-549-1500, filed 6/30/11, effective 7/1/11. Statutory Authority: RCW 74.08.090, 74.09.510, 74.09.522, 42 U.S.C. 1396a(bb), 42 C.F.R. 405.2472, and 42 C.F.R. 491. WSR 10-09-030, § 388-549-1500, filed 4/13/10, effective 5/14/10. Statutory Authority: RCW 74.08.090, 74.09.510, 74.09.522, 42 C.F.R. 405.2472, 42 C.F.R. 491. WSR 08-05-011, § 388-549-1500, filed 2/7/08, effective 3/9/08.]

NEW SECTION

WAC 182-549-1600 Rural health clinics—Appeals related to overpayments. An overpayment assessment by the agency against an RHC that was identified in the annual managed care reconciliation (see WAC 182-549-1450) may be appealed based on WAC 182-502-0230 and RCW 41.05A.170. Administrative hearing appeals are governed by chapter 34.05 RCW (Administrative Procedure Act) and chapter 182-526 WAC (HCA administrative hearing rules).

[]

NEW SECTION

WAC 182-549-1650 Rural health clinics—Appeals related to rate setting. (1) An RHC provider has a right to an administrative appeal of agency action related to rate setting under this chapter based on the rules in this section.

(a) The rules in WAC 182-502-0220 do not apply to appeals of agency action related to rate setting under this chapter.

(b) Appeals related to rate setting under this section are not governed by the Administrative Procedure Act, chapter 34.05 RCW.

(c) Any rate change that the agency grants that is the result of fraudulent practices on the part of the RHC, including as described under RCW 74.09.210, is exempt from the appeal provisions in this chapter.

(d) An RHC who fails to submit requested information as outlined in this chapter will be determined to have abandoned their appeal.

(2) The first level of appeal.

(a) An RHC provider who wants to contest an agency action concerning the reimbursement rate must file a written appeal with the agency. Written appeals must be sent to the address provided in the rate notification letter.

(b) The RHC must file the appeal within 60 calendar days of the date of the rate notification letter from the agency, unless an extension has been granted.

(i) The agency may grant a time extension for the appeal period if the RHC makes such a request before the expiration of the 60-day period.

(ii) The agency does not consider an appeal filed after the 60-day period unless an extension is granted by the agency.

(c) The appeal must include the following:

(i) A statement of the specific issue being appealed;

(ii) Supporting documentation; and

(iii) A request for the agency to recalculate the rate.

(d) When an RHC appeals a portion of a rate, the agency may review all components of the reimbursement rate.

(e) To complete a review of the appeal, the agency may do one or both of the following:

(i) Request additional information;

(ii) Conduct an audit of the documentation provided.

(f) The agency issues a decision or requests additional information within 60 calendar days of receiving the rate appeal request.

When the agency requests additional information:

(i) The RHC has 45 calendar days from the date of the request to submit the additional information to the agency; and

(ii) The agency issues a decision within 30 calendar days of receipt of the additional information.

(g) Any rate increase or decrease resulting from an appeal is effective retroactively to the rate effective date in the notification letter. The exception is identified in (h) of this subsection.

(h) If an appeal is related to the denial of a change in scope rate adjustment application, any rate adjustment effective date is established by the following rules:

(i) For prospective change in scope, the effective date of the rate adjustment is established by WAC 182-549-1500 (2)(d);

(ii) For retrospective change in scope, the effective date of the rate adjustment is established by WAC 182-549-1500 (2)(e);

(iii) For a post change in scope of services, the effective date of the rate adjustment is established by 182-549-1500 (5)(e).

(3) The second level of appeal.

(a) When an RHC disagrees with a rate review decision from the first level of appeal, it may file a request along with supporting documentation for a dispute conference with the agency. For this section "dispute conference" means an informal administrative appeal to resolve RHC disagreements with an agency action not resolved at the first level of appeal.

(b) If an RHC files a request for a dispute conference, it must submit the request to the agency within 30 calendar days after the date of the rate review decision.

(i) Any request for a dispute conference must be sent to the address indicated in the rate review decision.

(ii) The agency does not consider dispute conference requests submitted after the 30-day period for the first level decision.

(c) The agency conducts the dispute conference within 90 calendar days of receiving the request.

(d) The agency-director designee issues the final decision within 30 calendar days of the conference. Extensions of time for extenuating circumstances may be granted by the agency-director designee.

(e) Any rate increase or decrease resulting from a dispute conference decision is effective on the date specified in the dispute conference decision.

(f) The dispute conference is the final level of administrative appeal within the agency and precedes judicial action.

(4) The agency considers an RHC who fails to attempt to resolve disputed rates as provided in this section has abandoned the dispute.

[]

WSR 22-22-063

PERMANENT RULES

DEPARTMENT OF AGRICULTURE

[Filed October 28, 2022, 11:25 a.m., effective December 1, 2022]

Effective Date of Rule: December 1, 2022.

Purpose: The department is amending WAC 16-390-240 USDA audit verification and terminal market inspection fees, to adopt fees identical to, and not less than, fees adopted by the United States Department of Agriculture, Agricultural Marketing Service (USDA-AMS) as published in the Federal Register (Vol. 87, No. 114) on June 14, 2022, under the "Fresh Fruits, Vegetables, and Other Products (Inspection, Certification, and Standards)" table with an effective date of October 1, 2022. These changes are necessary to comply with the department's cooperative agreement with USDA-AMS for services the department provides as a "federal-state inspection agency."

Citation of Rules Affected by this Order: Amending WAC 16-390-240.

Statutory Authority for Adoption: RCW 15.17.030, [15.17].140(2), [15.17].150, and [15.17].270.

Adopted under notice filed as WSR 22-17-120 on August 23, 2022.

Number of Sections Adopted in Order to Comply with Federal Statute: New 0, Amended 0, Repealed 0; Federal Rules or Standards: New 0, Amended 1, Repealed 0; or Recently Enacted State Statutes: New 0, Amended 0, Repealed 0.

Number of Sections Adopted at the Request of a Nongovernmental Entity: New 0, Amended 0, Repealed 0.

Number of Sections Adopted on the Agency's own Initiative: New 0, Amended 1, Repealed 0.

Number of Sections Adopted in Order to Clarify, Streamline, or Reform Agency Procedures: New 0, Amended 0, Repealed 0.

Number of Sections Adopted using Negotiated Rule Making: New 0, Amended 0, Repealed 0; Pilot Rule Making: New 0, Amended 0, Repealed 0; or Other Alternative Rule Making: New 0, Amended 0, Repealed 0.

Date Adopted: October 28, 2022.

Derek I. Sandison
Director

OTS-4005.1

AMENDATORY SECTION (Amending WSR 19-18-047, filed 8/30/19, effective 9/30/19)

WAC 16-390-240 USDA audit verification and terminal market inspection fees. WSDA performs audit and inspection services requested by customers under a "cooperative agreement" with the United States Department of Agriculture's Agricultural Marketing Service (USDA/AMS). Under USDA/AMS rules, WSDA provides these services as a "federal-state inspection agency." Under USDA/AMS regulations and the cooperative agreement, the fees that WSDA charges for these services must be no less than the current USDA/AMS fees for these services. The applicable current USDA/AMS fees were published in the Federal Register in Vol. (~~(84, No. 83 on April 30, 2019)~~) 87, No. 114 on June 14, 2022, under

the "Fresh Fruits, Vegetables, and Other Products (Inspection, Certification, and Standards)" table and, for the mileage fee related to terminal market inspection, for incorporation in the USDA/AMS "General Market Manual" at Appendix II, "Schedule of User Fees." In conformity with the cooperative agreement, WSDA adopts the same applicable fees for these services as set forth in this section.

(1) Mileage related to audit verification services is charged at the rate established by the Washington state office of financial management at the time the service was performed.

(2) Specialty crop fees/audit and terminal market fees:

Quality and Condition Inspections for Whole Lots	((\$210.00) <u>\$225.00</u> per lot		
Quality and Condition Half Lot or Condition-Only Inspections for Whole Lots	((\$174.00) <u>\$186.00</u> per lot		
Condition Half Lot	((\$161.00) <u>\$172.00</u> per lot		
Quality and Condition or Condition-Only Inspections for Additional Lots of the Same Product	((\$96.00) <u>\$103.00</u> per lot		
Dockside Inspections - Each Package Weighing <30 lbs.	\$0.044 per pkg.		
Dockside Inspections - Each Package Weighing >30 lbs.	\$0.068 per pkg.		
Charge per Individual Product for Dockside Inspection	((\$210.00) <u>\$225.00</u> per lot		
Charge per Each Additional Lot of the Same Product	((\$96.00) <u>\$103.00</u> per lot		
Inspections for All Hourly Work	Regular	Overtime	Holiday
	((\$93.00) <u>\$100.00</u>	((\$113.00) <u>\$137.00</u>	((\$134.00) <u>\$175.00</u>
Audit Services - ((State)) <u>Federal</u>	((\$115.00) <u>\$132.00</u> per audit	((N/A))	((N/A))
<u>Audit Services - State</u>	<u>\$132.00 per audit</u>		
<u>GFSI Certification Fee²</u>	<u>\$250.00 per audit</u>		

² Global Food Safety Initiative (GFSI) Certification Fee—\$250 per GFSI audit to recoup the costs associated with attaining technical equivalency to the GFSI benchmarking requirements.

(3) The mileage fee related to terminal market inspection services is \$1.96 per mile. Round trip mileage will be charged from an inspector's assigned location to the inspection site.

[Statutory Authority: RCW 15.17.030, [15.17].140(2), [15.17].150, and [15.17].270. WSR 19-18-047, § 16-390-240, filed 8/30/19, effective 9/30/19. Statutory Authority: RCW 15.17.030, [15.17].140(2), [15.17].150, [15.17].270 and chapter 34.05 RCW. WSR 18-21-167, § 16-390-240, filed 10/23/18, effective 11/23/18; WSR 17-24-077, § 16-390-240, filed 12/5/17, effective 1/5/18. Statutory Authority: RCW 15.17.140(2), 15.17.040 [15.17.030], chapters 17.24 and 34.05 RCW. WSR 14-24-086, § 16-390-240, filed 12/1/14, effective 1/1/15. Statutory Authority: RCW 15.17.050, 2012 2nd sp.s. c 7, and chapter 34.05 RCW. WSR 12-19-040, § 16-390-240, filed 9/12/12, effective 10/13/12. Statutory Authority: Chapters 15.17 and 34.05 RCW. WSR 07-16-084, § 16-390-240, filed 7/30/07, effective 8/30/07. Statutory Authority: Chapters 15.17, 34.05 RCW, and 2003 1st sp.s. c 25. WSR 04-11-078, § 16-390-240, filed 5/18/04, effective 6/18/04.]

WSR 22-22-072

PERMANENT RULES

WASHINGTON STATE PATROL

[Filed October 31, 2022, 11:13 a.m., effective January 1, 2023]

Effective Date of Rule: January 1, 2023.

Purpose: Chapter 212-80 WAC currently sets a rule for chapter 18.160 RCW, Fire system sprinkler contractors, and chapter 18.270 RCW Fire protection sprinkler fitting. Due to differing definitions in RCW, and the fact that RCW apply to separate licenses and certifications within the sprinkler industry, a single WAC has created confusion when interpreting the rule and determining violations with appropriate enforcement.

Industry often tries to apply chapter 18.160 RCW requirements to fitters based on language in chapter 212-80 WAC. Authorities having jurisdiction are often confused and have misapplied the laws and rule when creating local licensing and permitting requirements.

Increase fees for certificate of competency holders, sprinkler fitters, and certification exams to continue to adequately support the program and services offered.

Citation of Rules Affected by this Order: New chapter 212-90 WAC; and amending chapter 212-80 WAC.

Statutory Authority for Adoption: Chapter 18.160 and 18.270 RCW.

Adopted under notice filed as WSR 22-19-071 on September 19, 2022.

Changes Other than Editing from Proposed to Adopted Version: A nonsubstantive change was made between the proposed and adopted rule versions. WAC 212-90-098 (2)(c) added that trainee sprinkler fitter certifications are exempt from the biennial certification fee.

Number of Sections Adopted in Order to Comply with Federal Statute: New 0, Amended 0, Repealed 0; Federal Rules or Standards: New 0, Amended 0, Repealed 0; or Recently Enacted State Statutes: New 0, Amended 0, Repealed 0.

Number of Sections Adopted at the Request of a Nongovernmental Entity: New 0, Amended 0, Repealed 0.

Number of Sections Adopted on the Agency's own Initiative: New 19, Amended 29, Repealed 0.

Number of Sections Adopted in Order to Clarify, Streamline, or Reform Agency Procedures: New 19, Amended 29, Repealed 0.

Number of Sections Adopted using Negotiated Rule Making: New 0, Amended 0, Repealed 0; Pilot Rule Making: New 0, Amended 0, Repealed 0; or Other Alternative Rule Making: New 0, Amended 0, Repealed 0.

Date Adopted: October 31, 2022.

John R. Batiste
Chief

OTS-4051.3

AMENDATORY SECTION (Amending WSR 14-03-019, filed 1/7/14, effective 2/7/14)

WAC 212-80-001 Purpose. The purpose of this chapter is to adopt rules to a single statewide standard of performance and compliance for

the licensing of fire protection sprinkler system contractors, the issuance of certificates of competency, and the issuance of civil fines for violations of any provision of chapter 18.160 (~~(or 18.270)~~) RCW or any provision of this chapter.

[Statutory Authority: RCW 18.270.900 and 18.160.030. WSR 14-03-019, § 212-80-001, filed 1/7/14, effective 2/7/14. Statutory Authority: RCW 18.270.900. WSR 09-01-114, § 212-80-001, filed 12/19/08, effective 1/19/09. Statutory Authority: Chapters 43.43 and 18.160 RCW. WSR 05-05-006, § 212-80-001, filed 2/4/05, effective 3/7/05. Statutory Authority: Chapters 43.63A and 18.160 RCW. WSR 91-14-086 (Order 91-06), § 212-80-001, filed 7/1/91, effective 8/1/91.]

AMENDATORY SECTION (Amending WSR 14-03-019, filed 1/7/14, effective 2/7/14)

WAC 212-80-005 Applicability. This chapter applies to any person performing as a fire protection sprinkler system contractor or certificate of competency holder as defined in chapter ~~(s)~~ 18.160 (~~(and 18.270)~~) RCW.

[Statutory Authority: RCW 18.270.900 and 18.160.030. WSR 14-03-019, § 212-80-005, filed 1/7/14, effective 2/7/14. Statutory Authority: RCW 18.270.900. WSR 09-01-114, § 212-80-005, filed 12/19/08, effective 1/19/09. Statutory Authority: Chapters 43.43 and 18.160 RCW. WSR 05-05-006, § 212-80-005, filed 2/4/05, effective 3/7/05. Statutory Authority: Chapters 43.63A and 18.160 RCW. WSR 91-14-086 (Order 91-06), § 212-80-005, filed 7/1/91, effective 8/1/91.]

AMENDATORY SECTION (Amending WSR 14-03-019, filed 1/7/14, effective 2/7/14)

WAC 212-80-010 Definitions. The following definitions will apply throughout this chapter:

(1) "Authority having jurisdiction (AHJ)" means the organization, office, or individual responsible for issuing permits, approving layout drawings, enforcing the requirements of a code or standard or approving materials, an installation, or a procedure. Usually, the AHJ is the building or fire official of the city or county in which the job site is located. In certain cases, such as health care facilities, transient accommodations, and day care facilities, the AHJ is the city or county building or fire official and the director.

(2) "Certificate" means a certificate of competency granted by the director under chapter ~~(18.270 or)~~ 18.160 RCW, and is valid within the state and all political subdivisions, and meets all of the requirements for license or certification that may be applied by the political subdivision.

(3) "Citation" means written notification issued by the director pursuant to RCW 18.160.120 (~~(or 18.270.020)~~) of a civil penalty for a violation of any provision of chapter 18.160 (~~(or 18.270)~~) RCW or this chapter. A citation may include, but is not limited to, a description of the violation(s) and a notice of civil penalty assessment.

(4) "Contractor" means any person that offers to contract for the design, installation, inspection, testing, maintenance, or repair of a fire protection sprinkler system or any part of such system under chapter 18.160 RCW.

(5) "Digital signature" means a secure signature in electronic form attached to an electronic record. Examples of electronic signatures include a digitized image of a "wet" signature, a graphical representation of a handwritten signature (constructed using graphics software or special fonts), or other icons or representations adopted by the person with the intent to sign the document. The digital signature must:

(a) Be unique to the certificate of competency holder;

(b) Be capable of independent verification;

(c) Be under the exclusive control of the certificate of competency holder;

(d) Transform the electronic record such that a recipient can determine that the record was signed by the certificate of competency holder; and

(e) Transform the electronic record such that a recipient can determine if the initial record was altered since the transformation was made.

(6) "Direct supervision" means the person providing direction, oversight, inspection, and observation of the work performed on the design, installation, inspection, testing, maintenance, or repair of a fire protection sprinkler system. Supervision requirements are met when the supervisor is on the premises for the duration of the working day.

(7) "Director" means the chief of the Washington state patrol through the director of fire protection or his or her designee.

(8) "Electronic" means electrical, digital, magnetic, optical, electromagnetic, or any other form of technology that involves similar capabilities.

(9) "Electronic record" means a record generated, communicated, received, or stored by electronic means for use in an information system or for transmission from one information system to another.

(10) "Fire protection sprinkler system" means an assembly of underground or overhead piping beginning at the connection to the primary water supply, whether public or private, that conveys water with or without other agents to dispersal openings or devices to extinguish, control, or contain fire or other products of combustion.

(11) "Formal hearing" means a hearing before a hearings officer where laws, rules, and evidence are presented, considered, and a decision is rendered.

(12) "General contractor" means a contractor whose business operations require the use of more than one building trade or craft for a single job, project, or building permit. A general contractor includes a person who superintends, or consults on, in whole or in part, work that falls within the definition of a contractor.

(13) "Hazard" means a condition which could result in injury or death to a person or damage to property.

(14) "Hearings request" means the written request for a formal hearing to contest a civil penalty.

(15) "Inspection" means a visual examination of a fire protection sprinkler system, or portion of the system, to verify that the system appears to be in operating condition, is free from physical damage, and complies with the applicable statutes and regulations adopted by the state.

(16) "Licensed contractor" means a contractor issued a license to perform fire protection sprinkler system work by the director pursuant to WAC 212-80-053 of this chapter.

(17) "Maintenance" means ~~((an inspection conducted by either a journey level or residential level sprinkler fitter or an inspection and testing technician (ITT) of all the components of an automatic fire protection sprinkler system and the))~~ in water-based fire protection systems, work performed to keep ~~((the system's))~~ equipment operable.

(18) "Mitigation or hearing officer" is the ~~((assistant))~~ state fire marshal or his or her designee who will preside over an informal, mitigation conference to discuss a civil penalty that has been assessed against a person for a violation of this chapter.

(19) ~~((("NFPA" means the National Fire Protection Association. The following national standards adopted by the NFPA apply to fire sprinkler suppression systems:))~~

~~((a))~~ "NFPA 13D" means, in addition to the definition contained in chapter 18.160 RCW, the inclusion of minor accessory uses such as garages normally found in residential occupancies. The following definitions will apply to the common types of sprinkler systems that can be installed in a NFPA 13D:

~~((i))~~ "Multipurpose piping sprinkler system((+))" means a piping system intended to serve both domestic needs in excess of a single fixture and fire protection needs from one common piping system throughout the dwelling unit(s).

~~((ii))~~ (20) "Network sprinkler system((+))" means a type of multipurpose system utilizing a common piping system supplying domestic fixtures and fire sprinklers where each sprinkler is supplied by a minimum of three separate paths.

~~((iii))~~ (21) "Passive purge system((+))" means a type of sprinkler system that serves a single toilet in addition to the fire sprinklers.

~~((iv))~~ (22) "Stand-alone sprinkler system((+))" means a sprinkler system where the above ground piping serves only fire sprinklers.

~~((v))~~ (23) "Antifreeze sprinkler system((+))" means a wet pipe system using automatic sprinklers that contains a liquid solution to prevent freezing of the system, and is intended to discharge the solution upon sprinkler operation, followed immediately by water from a water supply.

~~((vi))~~ (24) "Dry pipe sprinkler system((+))" means a sprinkler system employing automatic sprinklers that are attached to a piping system containing air or nitrogen under pressure, the release of which (as from the opening of a sprinkler) permits the water pressure to open a valve known as a dry pipe valve, and the water then flows into the piping system and out the opened sprinkler.

~~((vii))~~ (25) "Preaction sprinkler system((+))" means a sprinkler system employing automatic sprinklers that are attached to a piping system that contains air with a supplemental detection system installed in the same areas as the sprinklers.

~~((b))~~ "NFPA 13R" means the installation and design of fire suppression sprinkler systems in residential occupancies up to and including four stories in height in buildings not exceeding 60 ft (18 m) in height above grade plane.

~~((c))~~ "NFPA 13" means the installation and design of fire suppression sprinkler systems in commercial or high occupancy facilities.

~~(d))~~ (26) "NFPA 20" means the selection and installation of pumps, both centrifugal and positive displacement, that supply liquid for a private fire protection system.

~~((e))~~ (27) "NFPA 24" means the installation of the dedicated underground fire service main of a water based fire protection system.

~~((f))~~ (28) "NFPA 25" means the inspection, testing, and maintenance of water based fire protection systems.

~~((20))~~ (29) "NICET" means the National Institute for Certification in Engineering Technologies.

~~((21))~~ (30) "Person" means one or more individuals, legal representatives, partnerships, joint ventures, associations, corporations (whether or not organized for profit), business trusts, or any organized group of individuals and includes the state, state agencies, counties, municipal corporations, school districts, and other public corporations.

~~((22))~~ (31) "Qualified" means an individual who has demonstrated through education, training, examination, or national certifications the competency, skill, and ability necessary to perform any work covered or defined by this chapter and chapter ~~((s))~~ 18.160 ~~((and 18.270))~~ RCW to the satisfaction of a relevant jurisdiction. In matters of compliance with the licensing and certification requirements of this chapter and chapter ~~((s))~~ 18.160 ~~((and 18.270))~~ RCW, the relevant jurisdiction shall be the director.

~~((23))~~ (32) "Repair" means to restore by replacing a part of or putting together what is torn or broken on the fire protection sprinkler system.

~~((24))~~ (33) "Revoke" means the director will rescind a company's license or an individual's certificate. This action causes the company or individual to cease any work in the fire protection sprinkler system field in Washington state.

~~((25))~~ (34) "Suspend" means the director holds a company's license or individual's certificate inactive until such time as the director determines that the company or individual is in compliance with the requirements of this chapter and chapter ~~((s))~~ 18.160 ~~((and 18.270))~~ RCW.

~~((26))~~ (35) "Testing" means a procedure used to determine the status of a system as intended by conducting periodic physical checks on water-based fire protection systems such as water flow tests, fire pump tests, alarm tests, and trip tests of dry pipe, deluge, or preaction valves. These tests follow up on the original acceptance test at intervals specified in the appropriate chapter of NFPA 25.

~~((27))~~ ~~"Trainee" means a person who:~~

~~(a) Has been issued a training certificate by the director; and~~

~~(b) Is learning the fire protection sprinkler fitting trade under the supervision of a journey-level sprinkler fitter or residential sprinkler fitter working in his or her specialty.~~

~~(28))~~ (36) "Underground" means the portion of the fire protection sprinkler system that starts at the point where the last nonfire water use is taken from the supply mains. For the purpose of this subsection, "point where the last nonfire water use is taken from the supply mains" means the ((point just downstream of the last tap for domestic or processed water, the last water control valve that is required by a city or other authority, or the point where the water can be considered nonflowing and if shut off would shut off only the)) last valve, furthest from the riser, where water becomes nonflowing, which if shut off shuts off only the fire protection sprinkler system.

This subsection does not apply to residential multipurpose piping fire protection sprinkler systems.

Residential Example Street Water Main

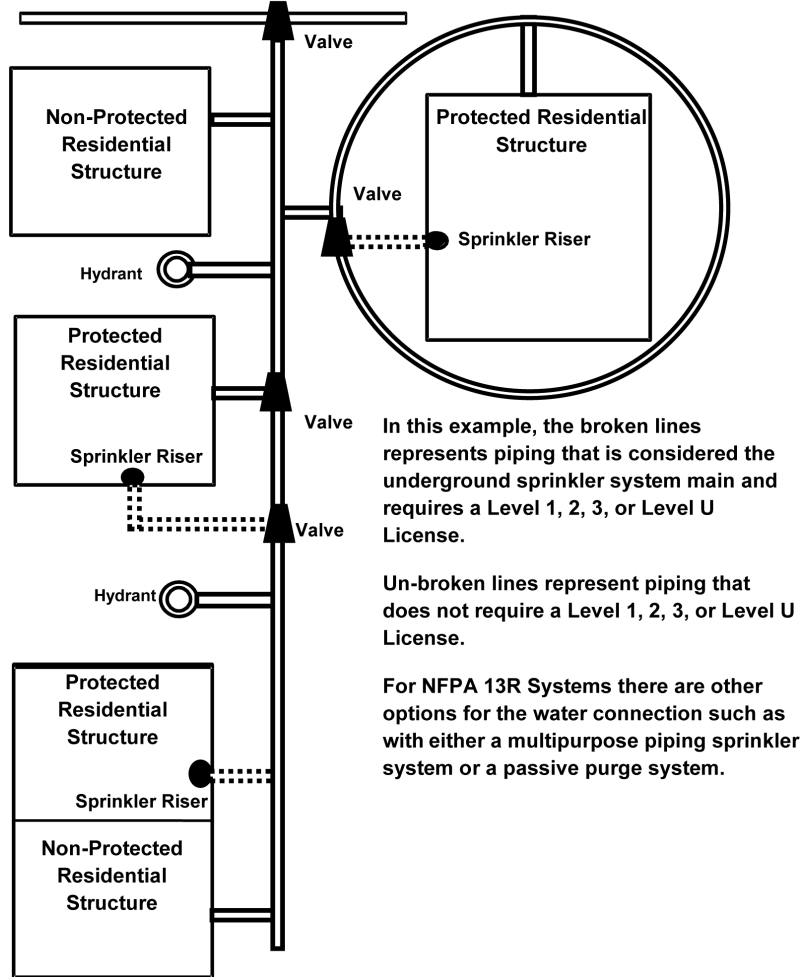

Commercial Example Street Water Main

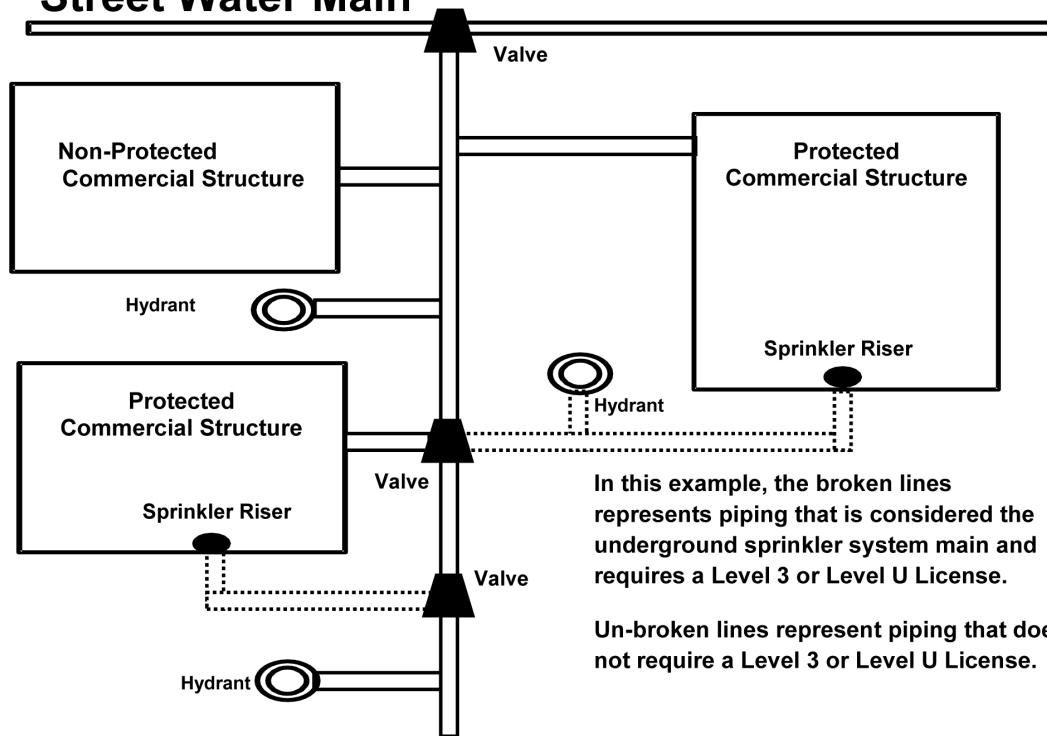

~~((29))~~ (37) "Violation" means any action, general or specific, inconsistent with the intent and letter of chapter ~~((s))~~ 18.160 ~~((and 18.270))~~ RCW and shall be further defined as:

- (a) "Level 1 violation" means a violation which poses a minimal hazard or threat to life and property in the event of a fire.
- (b) "Level 2 violation" means a violation which poses a significant hazard or threat to life or property in the event of a fire.
- (c) "Level 3 violation" means a violation which poses a substantial hazard or threat to life or property in the event of a fire.

[Statutory Authority: RCW 18.270.900 and 18.160.030. WSR 14-03-019, § 212-80-010, filed 1/7/14, effective 2/7/14. Statutory Authority: RCW 18.270.900. WSR 09-01-114, § 212-80-010, filed 12/19/08, effective 1/19/09. Statutory Authority: Chapters 43.43 and 18.160 RCW. WSR 05-17-099, § 212-80-010, filed 8/16/05, effective 9/16/05; WSR 05-05-006, § 212-80-010, filed 2/4/05, effective 3/7/05. Statutory Authority: Chapters 43.63A and 18.160 RCW. WSR 92-20-070 (Order 92-08), § 212-80-010, filed 10/5/92, effective 11/5/92; WSR 91-14-086 (Order 91-06), § 212-80-010, filed 7/1/91, effective 8/1/91.]

AMENDATORY SECTION (Amending WSR 14-03-019, filed 1/7/14, effective 2/7/14)

WAC 212-80-015 Compliance. (1) ~~((Who needs to comply with these rules?))~~ All fire protection sprinkler system contractors, certificate of competency holders, ~~((or trainees,))~~ and persons who design, install, inspect, test, or repair, fire protection sprinkler systems or

any part of such a system will comply with the provisions of this chapter.

(2) (~~Who is exempt from complying with this chapter?~~) Exceptions to subsection (1) of this section:

(a) Federal, state, and local government employees, or insurance inspectors when acting in their official capacities.

(b) A person acting under court order.

(c) A person who sells or supplies products or materials to a licensed contractor.

(d) A registered professional engineer in the state of Washington acting solely in a professional capacity.

(e) A person issued a certificate of competency by the Washington state department of labor and industries, under chapter 18.106 RCW, as a journey-level or residential specialty plumber or supervised plumber trainee installing a residential network fire protection sprinkler system connected to potable water who works for a contractor as defined by WAC 212-80-010(4) of this chapter.

(f) An owner or occupier of a single-family residence performing his or her own installation in that residence. It is the intent of this subsection that builders or contractors will not install their own sprinkler systems in single-family residences under their ownership that they plan to sell, lease, or rent.

(g) Full-time employee, or owner of a facility who is qualified to the satisfaction of the authority having jurisdiction to perform fire protection sprinkler work in said facility.

(h) An employee of a licensed electrical contractor installing or testing only the electronic signaling devices of a fire sprinkler system.

(i) A person who inspects, field tests, maintains, or repairs backflow prevention assemblies installed on potable water supplies to fire sprinkler systems and who is certified as a:

(i) Backflow assembly tester by the Washington state department of health, under chapters 70.119 RCW and 246-292 WAC; or

(ii) Backflow specialty plumber by the Washington state department of labor and industries, under chapters 18.106 RCW and 296-400A WAC, when repairing backflow prevention assemblies within a building.

(j) Work performed by companies or individuals under these exemptions must still comply with all relevant standards, codes, and local ordinances relevant to the work being performed. This includes evidencing any and all necessary competency and experience to the local fire code authority.

[Statutory Authority: RCW 18.270.900 and 18.160.030. WSR 14-03-019, § 212-80-015, filed 1/7/14, effective 2/7/14. Statutory Authority: RCW 18.270.900. WSR 09-01-114, § 212-80-015, filed 12/19/08, effective 1/19/09. Statutory Authority: Chapters 43.43 and 18.160 RCW. WSR 05-17-099, § 212-80-015, filed 8/16/05, effective 9/16/05; WSR 05-05-006, § 212-80-015, filed 2/4/05, effective 3/7/05. Statutory Authority: Chapters 43.63A and 18.160 RCW. WSR 94-24-032, § 212-80-015, filed 12/1/94, effective 1/1/95; WSR 92-20-070 (Order 92-08), § 212-80-015, filed 10/5/92, effective 11/5/92; WSR 91-14-086 (Order 91-06), § 212-80-015, filed 7/1/91, effective 8/1/91.]

AMENDATORY SECTION (Amending WSR 17-10-031, filed 4/26/17, effective 5/27/17)

WAC 212-80-018 License and certification requirements. (1) **Fire protection sprinkler contractors**, only a licensed contractor, who has at least one certificate of competency holder on staff certified to license level consistent with the contractor's license, by the director, can bid, offer to bid, contract, or perform the designing, installation, inspection, testing, maintenance, or repair of a NFPA fire protection sprinkler system or any part of such a system based on the level of the contractor license. The following levels will apply to contractor licenses issued by the director:

- (a) **Level 1 contractor license** - Residential structures consistent with the definitions found within NFPA 13D.
- (b) **Level 2 contractor license** - Residential structures consistent with the definitions found within NFPA 13D, NFPA 13R, and NFPA 25. NFPA 24 is applicable only when the water main supplying the fire sprinkler system is equal to or greater than four inches in size.
- (c) **Level 3 contractor license** - Includes work defined by Levels 1 and 2. This license is applicable to structures and fire protection sprinkler systems defined in NFPA 13, NFPA 24, and NFPA 25.
- (d) **Level U contractor license** - Specialized license for underground work (NFPA 24) only.
- (e) **Level I&T (inspection and testing) contractor license** - Specialized license for inspection and testing work (NFPA 25). This license level allows for inspection or testing of a NFPA 13R or NFPA 13, wet and dry pipe fire protection sprinkler system, provided that the:
 - (i) Inspection and testing technician must limit his or her work on the fire protection sprinkler system to the contractor's license level; and
 - (ii) Testing and maintenance of fire protection sprinkler systems such as preaction, deluge, foam or fire pumps, will be performed only by contractors who are also qualified and licensed to design and install that type of system or fire pump.

Chart 1: Fire Protection Sprinkler Contractors

Level of Contractor License	Standard Defining Work to be Performed				
	NFPA 13D	NFPA 13R	NFPA 13	NFPA 24	NFPA 25
Level 1 Contractor One- and two-family dwellings and manufactured homes	Yes	No	No	No	No
Level 2 Contractor Residential Occupancies Up To and Including Four Stories in Height	Yes	Yes	No	No Only if water main supplying the sprinkler system is equal or greater than 4 inches in size. (See WAC 212-80-018 (1)(b))	Yes (See WAC 212-80-018 (e)(i))
Level 3 Contractor All Types of Structures	Yes	Yes	Yes	Yes	Yes (See WAC 212-80-018 (e)(i))
Level U Contractor Underground	No	No	No	Yes	No

Level of Contractor License	Standard Defining Work to be Performed				
	NFPA 13D	NFPA 13R	NFPA 13	NFPA 24	NFPA 25
Level I&T Inspection and Testing Contractor	No	No	No	No	Yes Inspection/testing only (See WAC 212-80-018 (e)(ii))

(2) **Fire protection sprinkler system certification** - Only a certificate of competency holder may prepare layout drawings or install, inspect, test, maintain, or repair a fire protection sprinkler system or any part of such a system based on his or her ((design)) certification level.

(a) **Design certification** - The following levels will apply to design certifications issued by the director:

(i) **Level 1 design certification** - NFPA 13D.

(ii) **Level 2 design certification** - NFPA 13D or NFPA 13R, and underground work (NFPA 24) when the designed and installed underground main is four inches or greater in size ((or inspection, testing, and maintenance (NFPA 25))) for NFPA 13R.

(iii) **Level 3 design certification** - NFPA 13, NFPA 13R, or NFPA 13D, and underground work (NFPA 24) ((, and inspection, testing, and maintenance (NFPA 25))) for NFPA 13D, NFPA 13R, and NFPA 13.

(b) **Specialized certifications** - The following level will apply to specialized certifications issued by the director:

(i) **Level U certification** - NFPA 24; perform and supervise the installation, inspection, maintenance, repair, and testing of the underground fire protection sprinkler underground piping.

(ii) **Level ITT - Inspection and testing technician** - NFPA 25 for inspection or testing of a NFPA 13R or NFPA 13 ((, wet and dry pipe fire protection sprinkler)). The inspection and testing technician must limit his or her work to the ((inspection and testing)) employing contractor's license level ((under subsection (1)(e) of this section.

~~(c) **Sprinkler fitter certifications** - The following levels will apply to specialized certifications issued by the director:~~

~~(i) **Journey-level sprinkler fitter certification** - Installs, dismantles, alters, maintains, repairs, and corrects all types of sprinkler, standpipe, hose, or other hazard systems for fire protection purposes that are an assembly of piping, conduit, tubing, or hose regardless of the material composition beginning at the connection to the primary water supply. Also includes sprinkler tank heater, air lines tanks, pumps, equipment, appurtenances and all other related components attached thereto inside or outside of the building.~~

~~(ii) **Residential-level sprinkler fitter certification** - Limited to installation, maintenance, and repair of the fire protection sprinkler system of residential occupancies as defined by NFPA 13D and NFPA 13R. A residential level sprinkler fitter certification may also perform installation and repair of NFPA 13 fire protection sprinkler systems and components while under the direct supervision of a certified journey-level sprinkler fitter.~~

~~(iii) **Trainee-level sprinkler fitter certification** - Limited to performing sprinkler fitter work under the direct supervision of a journey-level sprinkler fitter or residential sprinkler fitter certified to perform the type of work the trainee-level sprinkler fitter is performing).~~

Chart 2: Fire Protection Sprinkler Certifications

Level of Certificate of Competency Holder - See Note (1)	Standard Defining Work That May Be Performed				
	NFPA 13D	NFPA 13R	NFPA 13	NFPA 24	NFPA 25
Level 1 Design Certification	Yes	No	No	No	No
Level 2 Design Certification	Yes	Yes	No	Yes (Restricted to only certain NFPA 13R systems) (see WAC 212-80-018 (1)(b))	((Yes (Restricted to only 13R systems))) <u>No</u>
Level 3 Design Certification	Yes	Yes	Yes	Yes	((Yes)) <u>No</u>
Level U Certification	No	No	No	Yes	No
Level ITT Certification	No	No	No	No	Yes (See subsection (1)(e) of this section for exceptions) (Limited by contractor licensing level)
(Journey-Level Sprinkler Fitter	Yes	Yes	Yes	No	No
Residential-Level Sprinkler Fitter	Yes	Yes	Only if under the direct supervision of a journey-level sprinkler fitter	No	No
Trainee-Level Sprinkler Fitter	Only if under the direct supervision of a residential/ journey-level sprinkler fitter	Only if under the direct supervision of a residential/ journey-level sprinkler fitter	Only if under the direct supervision of a journey-level sprinkler fitter	No	No))

Chart 3: Certificate Level Required for Level of License

Contractor Level	1	2	3	U	I&T
Building Type	One- and two-family dwellings and manufactured homes	Dwellings up to and including four stories in height	All dwellings and commercial or high occupancy facilities	Dedicated underground fire service main of a water based fire protection system	Inspection((;)) and testing((; and maintenance)) of water based fire protection systems
Certificate of Competency Holder Level Needed to Qualify for License	1	2	3	U	ITT

(3) (~~May a person who has two levels of certification as provided by subsection (2) of this section work for two different licensed contractors if the person only uses one type of certification for each licensed contractor? No.~~) RCW 18.160.040(10) prohibits a certificate

of competency holder from working for more than one licensed contractor at any one time.

~~((4) May a contractor obtain a fire protection sprinkler system license if the contractor employs only sprinkler fitters? No. A sprinkler fitter may only install piping from approved plans with a design certification.))~~

[Statutory Authority: RCW 18.270.900 and 18.160.030. WSR 17-10-031, § 212-80-018, filed 4/26/17, effective 5/27/17; WSR 14-03-019, § 212-80-018, filed 1/7/14, effective 2/7/14. Statutory Authority: RCW 18.270.900. WSR 09-01-114, § 212-80-018, filed 12/19/08, effective 1/19/09. Statutory Authority: Chapters 43.43 and 18.160 RCW. WSR 05-17-099, § 212-80-018, filed 8/16/05, effective 9/16/05; WSR 05-05-006, § 212-80-018, filed 2/4/05, effective 3/7/05.]

AMENDATORY SECTION (Amending WSR 14-03-019, filed 1/7/14, effective 2/7/14)

WAC 212-80-023 Authority having jurisdiction. (1) ~~((Does a fire protection sprinkler system contractor need to obtain approval from the authority having jurisdiction? Yes.))~~ The fire protection sprinkler systems contractor must obtain approval from the authority having jurisdiction. The authority having jurisdiction must approve plans, specifications, calculations, contractor's materials and test certificates, and final approval. The authority having jurisdiction may conduct an approved flow test of heads as part of the approval for 13D fire protection sprinkler systems.

(2) ~~((Are there circumstances when the authority having jurisdiction is the director? Yes.))~~ In certain types of occupancies the authority having jurisdiction may be the director and the building or fire official of the city or county in which the installation is located. Generally, these dual responsibilities occur in health care facilities, transient accommodations, and day care facilities. In matters concerning compliance with chapter ~~((s))~~ 18.160 ~~((and 18.270))~~ RCW, or this chapter, the director will be considered the authority having jurisdiction.

(3) ~~((Who has the responsibility to determine which agency is the authority having jurisdiction?))~~ It is the responsibility of the licensed contractor or certificate of competency holder to ascertain which agency or agencies have jurisdiction. If there is a question of which agency is the authority having jurisdiction, the licensed contractor or certificate of competency holder should contact the director.

[Statutory Authority: RCW 18.270.900 and 18.160.030. WSR 14-03-019, § 212-80-023, filed 1/7/14, effective 2/7/14. Statutory Authority: RCW 18.270.900. WSR 09-01-114, § 212-80-023, filed 12/19/08, effective 1/19/09. Statutory Authority: Chapters 43.43 and 18.160 RCW. WSR 05-05-006, amended and recodified as § 212-80-023, filed 2/4/05, effective 3/7/05. Statutory Authority: Chapters 43.63A and 18.160 RCW. WSR 91-14-086 (Order 91-06), § 212-80-025, filed 7/1/91, effective 8/1/91.]

AMENDATORY SECTION (Amending WSR 14-03-019, filed 1/7/14, effective 2/7/14)

WAC 212-80-033 Posting requirements—License, certificates, and license number. (1) (~~What are the posting requirements for the fire protection sprinkler system contractor's license and employees' certificate?~~) All licenses and certificates must be posted as follows:

(a) Each license and certificate issued under chapter 18.160 RCW must be posted in a conspicuous place in the licensed contractor's place of business.

(b) (~~For certificates issued under chapter 18.270 RCW, the certificate holder must be in possession of his or her wallet card and display it upon request to the authority having jurisdiction.~~

~~(c)~~) All bids, advertisements, proposals, offers, and installation drawings for fire protection sprinkler systems must prominently display the fire protection sprinkler system contractor's license number.

~~(d)~~) (c) All inspection and testing certificates, documentation, or other such records of work must have affixed to them:

(i) The inspection and testing technician certificate number;

(ii) The signature of the inspection and testing technician; and

(iii) The date of signature.

(2) (a) Every certificate of competency holder must be in possession of his or her wallet card and display it upon request to the authority having jurisdiction.

(b) The wallet card must either be on the certificate of competency holder (wallet, lanyard, article of clothing, etc.) or readily accessible.

(3) Failure to comply with this section constitutes a Level 1 violation for each occurrence.

[Statutory Authority: RCW 18.270.900 and 18.160.030. WSR 14-03-019, § 212-80-033, filed 1/7/14, effective 2/7/14. Statutory Authority: Chapters 43.43 and 18.160 RCW. WSR 05-05-006, recodified as § 212-80-033, filed 2/4/05, effective 3/7/05. Statutory Authority: Chapters 43.63A and 18.160 RCW. WSR 91-14-086 (Order 91-06), § 212-80-100, filed 7/1/91, effective 8/1/91.]

AMENDATORY SECTION (Amending WSR 14-03-019, filed 1/7/14, effective 2/7/14)

WAC 212-80-038 Municipality, county, or state regulations. (1) (~~Does chapter 18.160 RCW or this chapter limit the power of a municipality, county, or state to require persons engaged in the sprinkler trade to obtain a permit? No. The municipality, county, or state~~)

Nothing in this chapter or chapter 18.160 RCW limits the power of a municipality, county, or state to regulate(s) the quality and character of work performed by contractors through a system of permits, fees, and inspections which are designed to assure compliance with and aid in the implementation of state and local building laws or to enforce other local laws for the protection of the public health and safety.

(2) (~~Does chapter 18.160 RCW or this chapter limit the power of a municipality, county, or state, to require those engaged in the~~

~~sprinkler trade to obtain a permit? No.~~) Nothing in this chapter or chapter 18.160 RCW limits the authority of the municipality, county, or state ((may)) to adopt any system of permits requiring submission to and approval by the municipality, county, or the state of layout drawings and specifications for work to be performed by contractors before commencement of the work.

(3) ~~((Does chapter 18.160 RCW or this chapter limit the power of a municipality, county, or state, to require licensing or certification apart from the requirements provided by chapter 18.160 RCW or this chapter? Yes.))~~ A municipality, county, or state may not enact a regulation or requirement to require any licensing or certification apart from the requirements provided by chapter 18.160 RCW and this chapter unless the program was in place before 1991.

(4) ~~((Are permits or permission from the authority having jurisdiction required before performing sprinkler work? Yes.))~~ Licensed contractors and certificate of competency holders must comply with the authority having jurisdiction's requirements to obtain permits or permission before the installation, repair, alteration, or addition of a fire protection sprinkler system. Failure to comply with this section constitutes a Level 2 violation.

(a) Except as provided by (b) of this subsection, when a licensed contractor ~~((or certificate holder))~~ submits a bid to work on a fire protection sprinkler system, the licensed contractor ~~((or certificate holder))~~ does not need to obtain permits or permission from the authority having jurisdiction.

(b) The licensed contractor or certificate of competency holder must verify whether a permit or permission is required from the authority having jurisdiction before installing, repairing, altering, adding, or removing any fire protection sprinkler system.

(5) ~~((Is an authority having jurisdiction required to verify that the contractor's license and certificate of competency stamp are valid? Yes.))~~ The authority having jurisdiction's official authorized to issue building or other related permits must ascertain that the fire protection sprinkler system contractor is duly licensed by requiring evidence of a valid fire protection sprinkler system contractor's license and a valid certificate of competency stamp consistent with the contractor's license.

(6) ~~((Does this regulation apply to a fire protection sprinkler system contractor performing work for any municipality, county, or state? Yes.))~~ Officials of any municipality, county, or the state are required to determine compliance with this chapter before awarding any contracts for the installation, inspection, testing, maintenance, repair, service, alteration, fabrication, or addition of a fire protection sprinkler system.

[Statutory Authority: RCW 18.270.900 and 18.160.030. WSR 14-03-019, § 212-80-038, filed 1/7/14, effective 2/7/14. Statutory Authority: Chapters 43.43 and 18.160 RCW. WSR 05-17-099, § 212-80-038, filed 8/16/05, effective 9/16/05; WSR 05-05-006, amended and recodified as § 212-80-038, filed 2/4/05, effective 3/7/05. Statutory Authority: Chapters 43.63A and 18.160 RCW. WSR 91-14-086 (Order 91-06), § 212-80-130, filed 7/1/91, effective 8/1/91.]

AMENDATORY SECTION (Amending WSR 14-03-019, filed 1/7/14, effective 2/7/14)

WAC 212-80-048 Subcontracting. (1) (~~(When is it not permissible to subcontract fire protection sprinkler system work?~~

~~(a))~~) Subcontracting work on a fire protection sprinkler system is not permitted:

~~((i))~~) (a) If the subcontractor does not have a current fire protection sprinkler system contractor's license consistent with the level of work performed on the fire protection sprinkler system; or

~~((ii))~~) (b) If the inspection and testing work is contracted to a contractor licensed by the department of labor and industries, but not a licensed fire protection sprinkler system contractor.

~~((b))~~) (c) Failure to comply with this section constitutes a Level 3 violation.

(2) (~~(When is subcontracting or contracting of fire sprinkler protection system work permitted?)~~) Subcontracting of any fire sprinkler protection system work is permissible:

(a) When a licensed general contractor bids on a project that involves a fire protection sprinkler system. All subcontracting by a licensed general contractor for fire sprinkler work must be performed by a licensed fire protection sprinkler system contractor; or

(b) When the subcontractor is a licensed fire protection sprinkler system contractor and licensed at a level consistent with the work performed on the fire protection sprinkler system.

[Statutory Authority: RCW 18.270.900 and 18.160.030. WSR 14-03-019, § 212-80-048, filed 1/7/14, effective 2/7/14. Statutory Authority: Chapters 43.43 and 18.160 RCW. WSR 05-05-006, § 212-80-048, filed 2/4/05, effective 3/7/05.]

AMENDATORY SECTION (Amending WSR 14-03-019, filed 1/7/14, effective 2/7/14)

WAC 212-80-053 Application for licensed fire protection sprinkler system contractor. (1) (~~(What are the prerequisites to apply for a fire protection sprinkler system contractor license?)~~) Applicants seeking a fire protection sprinkler system contractor's license must:

(a) Register the company structure with the secretary of state

(www.sos.wa.gov), RCW 23B.01.200;

(b) Submit a master business application with the department of licensing (www.dol.wa.gov) or through the department of labor and industries (www.lni.wa.gov) and receive a unified business identifier number and ~~((twelve))~~ 12 digit contractor number;

(c) Obtain a federal tax number from the Internal Revenue Service (www.irs.gov); and

(d) Register as a general or specialty contractor with the department of labor and industries under chapter 18.27 RCW.

(2) (~~(Once the prerequisites are met, how do you get licensed as a fire protection sprinkler contractor?)~~) To become a licensed contractor under this chapter, a person must:

(a) Be or have in his or her full-time employ a holder of a valid certificate of competency whose level is consistent with the license level the contractor is applying for as provided by WAC 212-80-018. If the certificate of competency holder is not certified when the fire

protection sprinkler system contractor submits an application for licensing, the certificate of competency holder's application must be submitted at the same time.

(b) Submit an application to the director on forms provided for the level of fire protection sprinkler system contractor license. The applicant must complete and provide to the director:

- (i) Initial application;
- (ii) Contractor license background;
- (iii) Affidavit of compliance for licensing; and
- (iv) Bond or assignment of deposit.

(c) Pay the fees required under WAC 212-80-073 for the applicable level of license.

(d) Meet the bonding requirements of WAC 212-80-078.

(e) Provide the business name registered with the department of labor and industries and provide the ((~~twelve~~)) 12 digit alphanumeric business license number assigned by that agency.

(3) All information submitted for a fire protection sprinkler system contractor license must be true and accurate.

(4) Failure to comply with this section constitutes a Level 3 violation.

(5) If the director finds that information or documents submitted by an applicant is false, misleading or has been altered in an effort to meet the requirements, the director will revoke the license pursuant to WAC 212-80-205.

[Statutory Authority: RCW 18.270.900 and 18.160.030. WSR 14-03-019, § 212-80-053, filed 1/7/14, effective 2/7/14. Statutory Authority: Chapters 43.43 and 18.160 RCW. WSR 05-17-099, § 212-80-053, filed 8/16/05, effective 9/16/05; WSR 05-05-006, amended and recodified as § 212-80-053, filed 2/4/05, effective 3/7/05. Statutory Authority: Chapters 43.63A and 18.160 RCW. WSR 91-14-086 (Order 91-06), § 212-80-090, filed 7/1/91, effective 8/1/91.]

AMENDATORY SECTION (Amending WSR 14-03-019, filed 1/7/14, effective 2/7/14)

WAC 212-80-058 Fire protection sprinkler system contractor license not transferable. (1) ((~~Is a fire protection sprinkler system contractor's license transferable between companies? No.~~)) A license issued under this chapter is not transferable.

(2) ((~~If a currently licensed fire protection sprinkler system contractor merges or forms another company, can the license be reissued to a newly formed or incorporated company?~~)) If a currently licensed contractor merges or forms another company, that license can be reissued to the newly formed or incorporated company provided:

(a) The principal officers of the licensed company remain the same;

(b) The company continues, takes over, or otherwise reestablishes the bond required by chapter 18.160 RCW for licensing;

(c) The company continues to perform fire protection sprinkler system contractor work as defined by chapter 18.160 RCW;

(d) The company employs certificate of competency holders of the appropriate levels; and

(e) The company meets the criteria necessary for licensing as a fire protection sprinkler contracting company as defined by chapter 18.160 RCW.

[Statutory Authority: RCW 18.270.900 and 18.160.030. WSR 14-03-019, § 212-80-058, filed 1/7/14, effective 2/7/14. Statutory Authority: RCW 18.270.900. WSR 09-01-114, § 212-80-058, filed 12/19/08, effective 1/19/09. Statutory Authority: Chapters 43.43 and 18.160 RCW. WSR 05-05-006, amended and recodified as § 212-80-058, filed 2/4/05, effective 3/7/05. Statutory Authority: Chapters 43.63A and 18.160 RCW. WSR 91-14-086 (Order 91-06), § 212-80-105, filed 7/1/91, effective 8/1/91.]

AMENDATORY SECTION (Amending WSR 14-03-019, filed 1/7/14, effective 2/7/14)

WAC 212-80-063 Contractor responsibilities, certificate of competency holder employment. (1) (~~What are the requirements of the fire protection sprinkler system contractor regarding the employed certificate holder(s)?~~ A Level 1, 2, or 3) Any fire protection sprinkler system contractor must have at least one full-time certificate of competency holder, consistent with the license level as provided by WAC 212-80-018, employed to conduct business.

(2) (~~What happens if the licensed contractor no longer employs a certificate holder?~~) If a certificate of competency holder leaves the employment of the fire protection sprinkler system contractor, the contractor must comply with the following:

(a) From the date of separation of the design-only certificate of competency holder, the contractor will have six months or until the expiration of the current license, whichever occurs last, to (~~submit a new application~~) come into compliance. In order to be issued a new license, the contractor must employ a new person (either as owner or full-time employee) with the appropriate certificate level consistent with the contractor's license level as provided by WAC 212-80-018.

(b) The licensed contractor must notify the director of the loss of the primary design certificate of competency holder within (~~thirty~~) 30 calendar days. For the purposes of this subsection, (~~thirty~~) 30 calendar days commence on the certificate of competency holder's last day of employment for compensation. The licensed contractor's failure to notify the director:

(i) Within (~~thirty~~) 30 calendar days is a Level 1 violation.

(ii) Within (~~sixty~~) 60 calendar days is a Level 2 violation.

(iii) After (~~one hundred eighty~~) 180 calendar days is a Level 3 violation.

(c) A fire protection sprinkler system contractor may renew a license without employing a design certificate of competency holder if the six-month period crosses into a new license year and all appropriate fees are paid at the time of renewal. During the period in which the licensed contractor does not have a design certificate of competency holder, the licensed contractor must limit work on fire protection sprinkler systems to:

(i) Completing the active phase of existing work in progress which has been approved by the authority having jurisdiction, and may not receive new approvals from the authority having jurisdiction with-

out a design certificate of competency holder's number on the documents; or

(ii) Continuing installation on approved design plans, however, the contractor's material and test certificate for the system must be stamped by a certificate of competency holder in the full-time employ of the installing contractor.

(d) If a contractor fails to employ a design certificate of competency holder as required in this chapter, and the director has renewed the license, the director will suspend the contractor's license pursuant to WAC 212-80-205. The suspension will remain in effect until the contractor has a full-time design certificate of competency holder or a hearings officer denies the director's petition to suspend the license.

(e) When a licensed contractor no longer employs a design certificate of competency holder, and the contractor has not hired another design certificate of competency holder, the contractor may not bid on the design, installation, or repair of a fire protection sprinkler system, or any part of such system, that requires work inconsistent with the previously employed design certificate of competency holder's level.

(f) Any contractor that uses a current or former employee's certification stamp on any technical drawings not prepared by the (~~certificate holder~~) design certificate of competency holder is in violation of this chapter.

(g) Failure to comply with (c) through (f) of this subsection constitutes a Level 3 violation.

(3) (~~What happens when a Level U or I&T licensed contractor no longer employs a Level U or ITT certificate holder?~~) If a certificate of competency holder leaves the employment of a Level U or I&T fire protection sprinkler system contractor, the contractor must comply with the following:

(a) The licensed contractor is prohibited from continuing the supervision of underground fire sprinkler pipe installation and inspection, testing, and maintenance, of fire protection sprinkler systems. Failure to comply with this subsection constitutes a Level 3 violation and the director may summarily revoke the contractor's license.

(b) The contractor must immediately cease bidding on or starting any sprinkler work without the appropriate specialty certificate of competency holder.

(c) The contractor must notify the director within (~~thirty~~) 30 days after the specialty certificate of competency holder's last day of employment for compensation. Failure to comply with this subsection constitutes a Level 2 violation and the director may suspend the contractor's license pursuant to WAC 212-80-205.

(4) (~~What are the responsibilities of the fire protection sprinkler system contractor regarding the employed certificate holders?~~) The contractor is responsible for the work and actions of its employees regardless of the contractor's knowledge of any wrongdoing. The director may refuse to issue or renew a license to engage in the fire protection sprinkler system business for any of the reasons listed in WAC 212-80-205. The director may suspend or revoke the license or the certificate of competency holder's certificate to engage in the fire protection sprinkler system business for any of the reasons listed in WAC 212-80-205.

[Statutory Authority: RCW 18.270.900 and 18.160.030. WSR 14-03-019, § 212-80-063, filed 1/7/14, effective 2/7/14. Statutory Authority: RCW

18.270.900. WSR 09-01-114, § 212-80-063, filed 12/19/08, effective 1/19/09. Statutory Authority: Chapters 43.43 and 18.160 RCW. WSR 05-05-006, amended and recodified as § 212-80-063, filed 2/4/05, effective 3/7/05. Statutory Authority: Chapters 43.63A and 18.160 RCW. WSR 94-24-032, § 212-80-110, filed 12/1/94, effective 1/1/95; WSR 91-14-086 (Order 91-06), § 212-80-110, filed 7/1/91, effective 8/1/91.]

AMENDATORY SECTION (Amending WSR 14-03-019, filed 1/7/14, effective 2/7/14)

WAC 212-80-068 License renewals. (1) (~~(When are fire protection sprinkler system contractor licenses required to be renewed?)~~) All licensed fire protection sprinkler system contractors desiring to continue to be licensed must renew their license before January 1 of each year. The application for renewal must be made upon a form prescribed by the director. Any contractor not wishing to renew their license at the beginning of the year should notify the director of the intention not to renew.

(2) (~~(What happens if the contractor does not renew its license by the expiration date?)~~) A licensed contractor that fails to secure renewal of the license by the expiration date will:

(a) Not execute contracts for the design, installation, inspection, testing, maintenance or repair of fire protection sprinkler systems or any part of such a system in the state of Washington.

(b) Submit a ((new)) license reinstatement application pursuant to WAC 212-80-053 to obtain a fire sprinkler protection system contractor license.

(3) (~~(Are there reasons why the director would not renew a fire protection sprinkler system contractor license? Yes.)~~) The director will not renew a license that has been suspended by the director, or if the general or specialty license issued by the department of labor and industries has been suspended or revoked.

(4) (~~(When will the director not restore a fire protection sprinkler system contractor's suspended license?)~~) In addition to other provisions of this chapter, any of the following will constitute cause for the director, not to restore a license that has been suspended:

(a) Nonreceipt of payment of all delinquent fees;

(b) Nonreceipt of a late charge and/or application fee;

(c) Failure to comply with the bonding requirements of chapter 18.160 RCW; or

(d) Failure to obtain or show evidence of having a full-time employee certified as a certificate of competency holder of the appropriate level as defined by chapter 18.160 RCW.

[Statutory Authority: RCW 18.270.900 and 18.160.030. WSR 14-03-019, § 212-80-068, filed 1/7/14, effective 2/7/14. Statutory Authority: RCW 18.270.900. WSR 09-01-114, § 212-80-068, filed 12/19/08, effective 1/19/09. Statutory Authority: Chapters 43.43 and 18.160 RCW. WSR 05-05-006, amended and recodified as § 212-80-068, filed 2/4/05, effective 3/7/05. Statutory Authority: Chapters 43.63A and 18.160 RCW. WSR 94-24-032, § 212-80-115, filed 12/1/94, effective 1/1/95; WSR 92-20-070 (Order 92-08), § 212-80-115, filed 10/5/92, effective 11/5/92; WSR 91-14-086 (Order 91-06), § 212-80-115, filed 7/1/91, effective 8/1/91.]

AMENDATORY SECTION (Amending WSR 14-03-019, filed 1/7/14, effective 2/7/14)

WAC 212-80-073 Fire protection sprinkler system contractor license fees. (1) **Initial application fee** is (~~one hundred dollars~~) \$100 only charged once when a person makes the initial application for any fire protection sprinkler system contractor license.

(2) **Annual license fee** is paid by the contractor when:

(a) Submitting the application for a license; or

(b) Renewing the fire sprinkler system license. The annual license fees for each contractor license level are:

Level 1	\$100
Level 2	\$300
Level 3	\$1,500
Level U	\$1,500
Level I&T	\$1,000

(3) Except as provided by (b) of this subsection, the annual license fee as provided by subsection (2) (a) of this section will be prorated based upon the portion of the year such license is in effect, provided that:

(a) The annual license fee is allowed to be prorated only once in the history of the company.

(b) When the director finds that a contractor performed work covered by this chapter and chapter 18.160 RCW, the contractor must pay the full annual licensing fees, in addition to any penalties assessed by the director for unlicensed operation(s).

(c) The prorated fees are as follows:

Fire Sprinkler System Contractor Initial Prorated License Fees					
Month	1	2	3	U	I&T
January	(\$100.00)	\$300.00	\$1,500.00	\$1,500.00	\$1,000.00
	<u>Not prorated for January</u>				
February	\$92.00	\$275.00	\$1,375.00	\$1,375.00	\$920.00
March	\$83.00	\$250.00	\$1,250.00	\$1,250.00	\$830.00
April	\$75.00	\$225.00	\$1,125.00	\$1,125.00	\$750.00
May	\$67.00	\$200.00	\$1,000.00	\$1,000.00	\$670.00
June	\$58.00	\$175.00	\$875.00	\$875.00	\$580.00
July	\$50.00	\$150.00	\$750.00	\$750.00	\$500.00
August	\$42.00	\$125.00	\$625.00	\$625.00	\$420.00
September	\$33.00	\$100.00	\$500.00	\$500.00	\$330.00
October	\$25.00	\$75.00	\$375.00	\$375.00	\$250.00
November	\$17.00	\$50.00	\$250.00	\$250.00	\$170.00
December	\$8.00	\$25.00	\$125.00	\$125.00	\$80.00

(4) (~~Certificate~~) License fees are nonrefundable once the director has issued the (~~certificate~~) license.

(5) The director will invoice the annual license and certification fees for renewal to the contractor and the certificate of competency holders. Contractors may receive invoices for the certificate of competency holders they employ.

[Statutory Authority: RCW 18.270.900 and 18.160.030. WSR 14-03-019, § 212-80-073, filed 1/7/14, effective 2/7/14. Statutory Authority: RCW

18.270.900. WSR 09-01-114, § 212-80-073, filed 12/19/08, effective 1/19/09. Statutory Authority: Chapters 43.43 and 18.160 RCW. WSR 05-05-006, amended and recodified as § 212-80-073, filed 2/4/05, effective 3/7/05. Statutory Authority: Chapters 43.63A and 18.160 RCW. WSR 91-14-086 (Order 91-06), § 212-80-120, filed 7/1/91, effective 8/1/91.]

AMENDATORY SECTION (Amending WSR 14-03-019, filed 1/7/14, effective 2/7/14)

WAC 212-80-078 Contractor surety bonds. (1) (~~(Is the surety bond required by the department of labor and industries acceptable to the director for issuing a fire protection sprinkler system contractor license? No.~~)) A fire protection sprinkler system contractor must have a separate bond conditioned to compensate third-party losses caused by the acts of the contractor's principal or the principal's servant, officer, agent, or employees, in conducting the business registered or licensed under this chapter as follows:

(a) Level 3 or Level "U" fire protection sprinkler system contractor, must file with the director a surety bond executed by a surety company authorized to do business in the state of Washington, in the sum of (~~ten thousand dollars~~) \$10,000; or

(b) Level 1 or Level 2 systems or a contractor to be licensed as an inspection and testing contractor, must file with the director a surety bond executed by a surety company authorized to do business in the state of Washington, in the sum of (~~six thousand dollars~~) \$6,000.

SURETY BOND REQUIREMENT CHART

Level	1	2	3	U	I&T
Building Type By NFPA Standard	NFPA 13D	NFPA 13R	NFPA 13	NFPA 24	NFPA 25
Bond Amount	\$6,000	\$6,000	\$10,000	\$10,000	\$6,000

This is a separate bond from the one obtained to license with L&I.

(2) (~~(Can another type of security bond be used other than the surety bond? Yes.~~)) Upon approval by the director, cash or other security may substitute for a surety bond provided the value matches the appropriate level of bonding required under subsection (1) of this section and the following conditions are met:

(a) The value of property must be determined by an appraiser selected by the director and all appraisal fees will be paid by the fire protection sprinkler system contractor.

(b) The cash or other security substitute will be released one year after the expiration of the fire protection system contractor license issued by the director provided that there are no claims against the bond.

(3) (~~(What notice is required for cancellation of a bond?)~~) A cancellation of a surety bond or insurance policy is effective (~~thirty~~) 30 days after the director receives the cancellation notice or upon the cancellation date as specified by the surety company whichever occurs first. The cancellation notice must be sent to the director by certified or registered mail and contain the following information in this order:

(a) The name of the contractor, exactly as it appears on the contractor's license;

- (b) The contractor's license number (as issued by the department of labor and industries);
- (c) The contractor's business address;
- (d) The number of the bond or insurance policy that is to be canceled; and
- (e) The effective date of the bond that is to be canceled.
- (4) (~~(What happens if the bond is canceled or expires without renewal?)~~) If the surety company cancels or revokes the bond or a withdrawal of the surety company from the bond occurs, the director will suspend both the fire protection sprinkler system contractor license issued to the contractor, and the certifications of employee(s) employed by the contractor pursuant to WAC 212-80-205. The director may rescind the suspension action when the contractor files a new bond or reinstatement notice. The director will provide written notice to both the contractor and certificate of competency holders of the (~~license or certificate~~) suspension action. (~~This subsection does not apply to the certificates of commercial or residential installers under chapter 18.270 RCW.~~)

[Statutory Authority: RCW 18.270.900 and 18.160.030. WSR 14-03-019, § 212-80-078, filed 1/7/14, effective 2/7/14. Statutory Authority: RCW 18.270.900. WSR 09-01-114, § 212-80-078, filed 12/19/08, effective 1/19/09. Statutory Authority: Chapters 43.43 and 18.160 RCW. WSR 05-17-099, § 212-80-078, filed 8/16/05, effective 9/16/05; WSR 05-05-006, amended and recodified as § 212-80-078, filed 2/4/05, effective 3/7/05. Statutory Authority: Chapters 43.63A and 18.160 RCW. WSR 92-20-070 (Order 92-08), § 212-80-125, filed 10/5/92, effective 11/5/92.]

FIRE SPRINKLER CERTIFICATE OF COMPETENCY HOLDER

AMENDATORY SECTION (Amending WSR 14-03-019, filed 1/7/14, effective 2/7/14)

WAC 212-80-083 Stamps for NFPA 13D, 13R, and 13 systems certificate of competency holders. Certificate of competency holders for Level 1, Level 2, Level 3, and Level U will obtain a stamp each certification year to affix on all sprinkler related documents as provided by this chapter.

(1) **Will the stamp come with my certification?** When the director issues a certificate, the director will provide a Level 1, Level 2, Level 3, and Level U certificate of competency holder the information necessary to order a stamp. The cost of the stamp and obtaining a stamp will be the responsibility of the certificate of competency holder.

(2) **What is required on the stamp?** The stamp will conform to the following appearance specifications:

(a) The name and certification number of the certificate of competency holder;

(b) The name and license number of the certificate of competency holder's employer;

(c) The expiration date of the current certificate; and

(d) A place for the signature of the design certificate of competency holder and the date of the signature.

(3) **When is the stamp required to be used?** An original stamp and signature must appear in an easily recognizable manner on:

(a) Sprinkler system plans, calculations, and contractors' materials and test certificates submitted to the authority having jurisdiction.

(b) At least one set of approved plans and calculations, containing information as specified in subsection (1) of this section, must be maintained on the job site while the work is being performed.

(c) The cover sheet of hydraulic calculations.

(d) On all test certificates for fire protection sprinkler systems submitted to the authority having jurisdiction.

(4) Plans and calculations for "underground only" portions of fire protection sprinkler systems submitted to the authority having jurisdiction by a Level U licensed fire protection sprinkler contractor must be stamped by both the system designer and the certificate of competency holder for the licensed installing contractor seeking the permit. The Level U certification seal will only address matters of installation while the stamp for design must be either:

(a) A licensed professional engineer registered in the state of Washington; or

(b) A government employee acting in their official capacity; or

(c) The appropriate level certificate of competency holder and the Level U certificate of competency holder employed by the submitting contractor.

(5) **What are the documentation requirements for inspection and testing technicians?** Inspection and testing technicians must affix the certificate number and signature on all bids or documents related to the inspection and testing of a fire protection sprinkler system. The inspection and testing technician may affix the certificate number by handwriting or digital signature.

(6) **Can documentation be provided using an electronic record?**

(a) Yes. Electronic records may be submitted provided that:

(i) The electronic record must meet the applicable requirements of chapter 18.160 RCW and this chapter; and

(ii) The signature is an original "wet" signature, written by hand and applied by the identified registrant or a digital signature.

(b) The following guidelines will be used when submitting electronic records:

(i) An electronic stamp may be embedded in an electronic document as part of a template, drawing border, or cover sheet.

(ii) The certificate of competency holder is responsible for ensuring that the stamp is only affixed to documents personally prepared by or under his or her direct supervision.

(iii) If the stamp is combined with a digital signature into a single graphic entity, then it must:

(A) Be affixed by the certificate of competency holder in conjunction with the certificate of competency holder applying his or her digital signature to the document;

(B) Include a scanned image of a "wet" signature; and

(C) Be affixed only to the final documents.

(iv) A digital signature must be affixed by the certificate of competency holder to final documents that are distributed as an elec-

tronic record to meet the requirements of this section. The certificate of competency holder must maintain exclusive control ((of the passwords, private key, or security device that allows access)) to his or her digital signature.

(7) (~~What are the violations of this section?~~) Violations of this section includes:

(a) A certificate of competency holder altering, forging, or falsifying a certification stamp in order to submit bids or documents related to fire protection sprinkler system plans, calculations, permits, or any other documents that show the stamp being valid, constitutes a Level 3 violation.

(b) A certificate of competency holder using a stamp from previous employment with a licensed contractor while employed by another licensed contractor will constitute a Level 2 violation.

(c) A certificate of competency holder using an issued stamp from previous employment with a licensed contractor while not currently employed by a licensed contractor will constitute a Level 3 violation.

(d) A certificate of competency holder using an expired stamp will constitute a Level 3 violation.

(e) (i) A certificate of competency holder stamping documents that have been forwarded to the authority having jurisdiction for approval that were not prepared by the certificate of competency holder or an individual under his or her direct supervision constitutes a Level 3 violation.

(ii) Stamped documents submitted to the authority having jurisdiction for work other than design that does not clearly bear the seal of the designer shall constitute a Level 2 violation.

(f) A certificate of competency holder failing to affix the certificate stamp or inspection testing technician's number and signature on inspection forms constitutes a Level 1 violation.

(g) A certificate of competency holder obtaining a certification stamp while not holding a current and valid certificate of competency holder constitutes a Level 3 violation.

(h) Anyone who uses a certification seal and/or number that was not issued to them by the direction on any fire protection sprinkler system work for any reason constitutes a Level 3 violation.

(8) (~~May a licensed contractor hired by a person who has obtained a building, structure, or property through a foreclosure process complete the installation using a previous licensed fire protection sprinkler system contractor's design, uncompleted installation, and permit? No.~~) A licensed contractor hired by a person who has obtained a building, structure, or property through a foreclosure process may not use a previous licensed fire protection sprinkler system contractor's design, uncompleted installation, or permit. The licensed contractor must submit new plans with the certificate ((holder's)) of competency stamp affixed and obtain a new permit from the authority having jurisdiction for work that will be done under the licensed contractor's supervision. The decision to remove piping must be made in consultation with the authority having jurisdiction. The licensed contractor must obtain approval from the authority having jurisdiction for any portion of the fire protection sprinkler system that was not previously inspected and approved by the authority having jurisdiction.

[Statutory Authority: RCW 18.270.900 and 18.160.030. WSR 14-03-019, § 212-80-083, filed 1/7/14, effective 2/7/14. Statutory Authority: RCW 18.270.900. WSR 09-01-114, § 212-80-083, filed 12/19/08, effective

1/19/09. Statutory Authority: Chapters 43.43 and 18.160 RCW. WSR 05-17-099, § 212-80-083, filed 8/16/05, effective 9/16/05; WSR 05-05-006, amended and recodified as § 212-80-083, filed 2/4/05, effective 3/7/05. Statutory Authority: Chapters 43.63A and 18.160 RCW. WSR 94-24-032, § 212-80-035, filed 12/1/94, effective 1/1/95; WSR 92-20-070 (Order 92-08), § 212-80-035, filed 10/5/92, effective 11/5/92; WSR 91-14-086 (Order 91-06), § 212-80-035, filed 7/1/91, effective 8/1/91.]

AMENDATORY SECTION (Amending WSR 14-03-019, filed 1/7/14, effective 2/7/14)

WAC 212-80-088 Contractor's materials and test certificates.

(1) The certificate of competency holder must complete the contractor's material and test certificate(s), affix his or her certificate stamp, and forward the certificate(s) to the authority having jurisdiction.

(2) Contractor's material and test certificate forms must be of such form as accepted or approved by the authority having jurisdiction.

(3) The authority having jurisdiction and the building owner must retain copies of the contractor's materials and test certificate for a minimum of five years.

(4) The certificate of competency holder will not allow his or her stamp to be used to complete the contractor's materials and test certificate(s) that were not prepared personally by the certificate of competency holder or under his or her direct supervision. Failure to comply with this subsection constitutes a Level 2 violation.

[Statutory Authority: RCW 18.270.900 and 18.160.030. WSR 14-03-019, § 212-80-088, filed 1/7/14, effective 2/7/14. Statutory Authority: RCW 18.270.900. WSR 09-01-114, § 212-80-088, filed 12/19/08, effective 1/19/09. Statutory Authority: Chapters 43.43 and 18.160 RCW. WSR 05-05-006, amended and recodified as § 212-80-088, filed 2/4/05, effective 3/7/05. Statutory Authority: Chapters 43.63A and 18.160 RCW. WSR 94-24-032, § 212-80-040, filed 12/1/94, effective 1/1/95; WSR 91-14-086 (Order 91-06), § 212-80-040, filed 7/1/91, effective 8/1/91.]

AMENDATORY SECTION (Amending WSR 19-24-059, filed 11/27/19, effective 12/28/19)

WAC 212-80-093 Certificate of competency holder certification.

(1) (~~(How do I become a certificate holder?)~~) The issuance of a certificate of competency is dependent on employment with a licensed contractor. All applications for a certificate of competency must be submitted with the fire protection sprinkler system contractor's license application or under an existing license. A certificate application will not be processed without the fire protection sprinkler system contractor's license application unless they are currently licensed. All applications must be made on the forms provided by the director and include the required fees provided by WAC 212-80-098 and documen-

tation for the required level of certification as provided by this section.

(a) **For Level 1 design certification**, the applicant must:

(i) Have satisfactorily passed with a final score of ~~((eighty))~~ 80 percent or better an examination administered by the director, or present a copy of a current certificate from the National Institute for Certification in Engineering Technologies showing that the applicant has achieved Level 2 certification in the field of water-based fire protection system layout; or

(ii) Be a Washington licensed professional engineer.

(b) **For Level 2 design certification**, the applicant must:

(i) Present a copy of a current certificate from the National Institute for Certification in Engineering Technologies showing that the applicant has achieved a Level 2 in the field of water-based fire protection systems layout; or

(ii) Be a Washington licensed professional engineer.

(c) **For Level 3 design certification**, the applicant must either:

(i) Present a copy of a current certificate from the National Institute for Certification in Engineering Technologies showing that the applicant has achieved a Level 3 in the field of water-based fire protection systems layout; or

(ii) Be a Washington licensed professional engineer.

(d) **For Level U certification**, the applicant must have satisfactorily passed with a final score of ~~((eighty))~~ 80 percent or better an examination administered by the director.

(e) **For inspection and testing technician certification**, the applicant must:

(i) Possess a National Institute for Certification and Engineering Technologies Inspection, Testing and Maintenance Level 2 or Level 3 certification; or

(ii) Possess the American Society of Sanitary Engineers 15010 Field Technician Certification; and

~~((ii))~~ (iii) Perform work consistent with the employing contractor's licensing level.

~~(f) **For journey-level sprinkler fitter certification**, the applicant must:~~

~~(i) Provide evidence on the forms provided by the director of at least eight thousand hours of trade related fire protection sprinkler system experience in installation and repair;~~

~~(ii) Not have more than three thousand hours of the required eight thousand hours of experience in residential sprinkler fitting; and~~

~~(iii) Satisfactorily pass an examination provided by the director with a final score of eighty percent.~~

~~(g) **For residential sprinkler fitter certification**, the applicant must:~~

~~(i) Provide evidence on the forms provided by the director, of at least four thousand hours of trade related fire protection sprinkler system experience in installation, repair, and maintenance; and~~

~~(ii) Satisfactorily pass an examination provided by the director with a final score of eighty percent.~~

~~(h) **For journey- or residential-level sprinkler fitter training certification**, except as provided by (g) (i) of this subsection, the applicant must:~~

~~(i) Provide evidence to the director, on the forms provided by the director, of trade related employment by a licensed contractor;~~

~~(ii) Remain employed by a licensed contractor to maintain trainee status; and~~

~~(iii) Only engage in the fire protection sprinkler system trade when under the supervision of a certified journey level or residential installer.~~

(i)) **For a professional engineer** to act as a Level 1, 2, or 3 certificate of competency holder and be issued a stamp, the professional engineer must:

(i) Be licensed by the department of licensing;

(ii) Obtain a Level 1, Level 2, or Level 3 certificate;

(iii) Properly register with the department of licensing;

(iv) Complete the application process for certification provided by WAC 212-80-093;

(v) Pay fees provided by WAC 212-80-073;

(vi) Supply the director with proof that he or she holds a current, valid state of Washington registration as a professional engineer; and

(vii) Otherwise the professional engineer is exempt from certification when acting solely in a professional capacity as an engineer.

(2) Proof of competency to the satisfaction of the director is mandatory.

Certificate of Competency Holder Requirements				
Certificate of Competency Level	Application Required	Certification or Exam Required	Stamp Issued	Type of work performed by Certificate of Competency Holder
Level 1	Yes	NICET Level 2 or pass an exam (See WAC 212-80-093 (1)(a))	Yes	Designs NFPA 13D fire sprinkler systems ((or inspection, testing, maintenance)) (NFPA 25) for NFPA 13D
Level 2	Yes	NICET Level 2 (See WAC 212-80-093 (1)(b))	Yes	Designs NFPA 13D, 13R or certain NFPA 24 (Restricted to only certain NFPA 13R systems, see WAC 212-80-018 (1)(b)) fire sprinkler systems ((or inspection, testing, maintenance)) (NFPA 25) for NFPA 13D or 13R
Level 3	Yes	NICET Level 3 or 4 (See WAC 212-80-093 (1) (c))	Yes	Designs NFPA 13, 13D, 13R or 24 fire sprinkler systems ((or inspection, testing, maintenance)) (NFPA 25) for NFPA 13, 13D or 13R
Level "U"	Yes	Pass an exam (See WAC 212-80-093 (1) (d))	Yes	Supervises or performs the underground installation of fire sprinkler system piping

Certificate of Competency Holder Requirements				
Certificate of Competency Level	Application Required	Certification or Exam Required	Stamp Issued	Type of work performed by Certificate of Competency Holder
Inspection, Testing Technician (ITT) Employed by an Inspection & Testing Contractor	Yes	NICET Level 2 or ASSE 15010 (See WAC 212-80-093 (1) (e))	No	Performs inspection or testing on NFPA 13R or 13, wet and dry pipe fire protection systems only
Inspection, Testing Technician (ITT) Employed by a Level 2 Contractor	Yes	NICET Level 2 or ASSE 15010 (See WAC 212-80-093 (1) (e))	No	Performs inspection(,) and testing ((and maintenance)) on NFPA 13R or 13, wet and dry pipe fire protection systems only
Inspection, Testing Technician (ITT) Employed by a Level 3 Contractor	Yes	NICET Level 2 or ASSE 15010 (See WAC 212-80-093 (1) (e))	No	Same as ITT above and includes the testing of other fire protection systems such as preaction, deluge, foam, or fire pump
((Journey Sprinkler Fitter	Yes	Pass an exam (See WAC 212-80-093 (1) (f))	No	Installs and repairs NFPA 13D, 13R, or 13 fire sprinkler systems
Residential Sprinkler Fitter	Yes	Pass an exam (See WAC 212-80-093 (1) (g))	No	Installs, repairs, and performs maintenance on fire sprinkler systems in residential occupancies)
Professional Engineer (P.E.) Licensed in Washington State	Only if acting as a Level 1, 2 or 3 certificate of competency holder	Licensed with department of licensing	By DOL unless acting as a Level 1, 2, or 3 certificate of competency holder	Designs, evaluates or consults on fire protection fire sprinkler systems

(3) All information submitted by an applicant to the director to apply for a certificate must be true and accurate. If the director finds that information or documents submitted by an applicant is false, misleading, or has been altered in an effort to meet the requirements provided by this chapter, the finding will constitute a Level 3 violation.

(4) A violation of this section that involves a contractor allowing an employee to engage in performing fire protection sprinkler system work:

(a) Without a license or certificate, or with a license or certificate that has been expired for one or more years is a Level 3 violation.

(b) With a license or certificate that has been expired for more than ~~((ninety))~~ 90 days and less than one year is a Level 2 violation.

(c) With a license or certificate that has been expired less than ~~((ninety))~~ 90 days is a Level 1 violation.

~~((d) By engaging in the trade of fire sprinkler fitting without having a valid sprinkler fitter certificate of competency issued for the work being conducted is a level 3 violation.~~

~~(e) By a trainee sprinkler fitter engaging in the trade of fire sprinkler fitting without the direct supervision of a certified residential or journey sprinkler fitter is a level 3 violation.~~

~~(f) As a trainee without a trainee certificate but with the direct supervision of a certified residential or journey sprinkler fitter is a level 1 violation.)~~

[Statutory Authority: RCW 18.270.900 and 18.160.030. WSR 19-24-059, § 212-80-093, filed 11/27/19, effective 12/28/19; WSR 17-10-031, § 212-80-093, filed 4/26/17, effective 5/27/17; WSR 14-03-019, § 212-80-093, filed 1/7/14, effective 2/7/14. Statutory Authority: RCW 18.270.900. WSR 09-01-114, § 212-80-093, filed 12/19/08, effective 1/19/09. Statutory Authority: Chapters 43.43 and 18.160 RCW. WSR 05-17-099, § 212-80-093, filed 8/16/05, effective 9/16/05; WSR 05-05-006, amended and recodified as § 212-80-093, filed 2/4/05, effective 3/7/05. Statutory Authority: Chapters 43.63A and 18.160 RCW. WSR 94-24-032, § 212-80-045, filed 12/1/94, effective 1/1/95; WSR 91-14-086 (Order 91-06), § 212-80-045, filed 7/1/91, effective 8/1/91.]

AMENDATORY SECTION (Amending WSR 14-03-019, filed 1/7/14, effective 2/7/14)

WAC 212-80-098 Fees for certificate of competency holder. There are ~~((three))~~ four separate fees that may apply:

(1) **Application fee** is ~~((fifty dollars))~~ \$100 only charged once when a person makes the initial application for any of the certificates specified in this section. As long as the certificate of competency holder maintains continuous certification, the certificate of competency holder is not required to pay a subsequent application fee. Application fees are nonrefundable.

(2) Annual **certification fee** is ~~((fifty dollars))~~ \$100 paid each year the certificate of competency holder applies for certification renewal. The annual renewal fee:

(a) Is in addition to the initial application fee paid for the initial application; and

(b) ~~((Does not apply to journey, residential, or trainee sprinkler fitter certifications.))~~ Is nonrefundable once the certificate has been issued.

(3) **Prorated fee** is the initial certification fee prorated based on the portion of the year the certification is in effect before renewal on January 1st.

(a) Prorated fees are allowed only for the initial certificate.

(b) Renewals or reinstatements will not be prorated.

The prorated fees are as follows:

Annual Certificate Prorated Fees

January	((50))
	<u>Not prorated</u>
February	((44)) <u>\$92</u>
March	((40)) <u>\$83</u>
April	((36)) <u>\$75</u>
May	((32)) <u>\$67</u>
June	((28)) <u>\$58</u>

Annual Certificate Prorated Fees

July	((\$24) <u>\$50</u>)
August	((\$20) <u>\$42</u>)
September	((\$16) <u>\$33</u>)
October	((\$12) <u>\$25</u>)
November	((\$8) <u>\$17</u>)
December	((\$4) <u>\$8</u>)

(4) (~~Certificate fees are nonrefundable once the certificate has been issued~~) **Examination fee** is \$150, charged per examination, including retests.

Examination fees are nonrefundable.

[Statutory Authority: RCW 18.270.900 and 18.160.030. WSR 14-03-019, § 212-80-098, filed 1/7/14, effective 2/7/14. Statutory Authority: RCW 18.270.900. WSR 09-01-114, § 212-80-098, filed 12/19/08, effective 1/19/09. Statutory Authority: Chapters 43.43 and 18.160 RCW. WSR 05-05-006, amended and recodified as § 212-80-098, filed 2/4/05, effective 3/7/05. Statutory Authority: Chapters 43.63A and 18.160 RCW. WSR 91-14-086 (Order 91-06), § 212-80-050, filed 7/1/91, effective 8/1/91.]

AMENDATORY SECTION (Amending WSR 14-03-019, filed 1/7/14, effective 2/7/14)

WAC 212-80-108 Certificate not transferable. (1) (~~Is a certificate transferable to another person? No.~~) A certificate issued under this regulation is not transferable to another person.

(2) (~~Is a certificate transferable to another employer? Yes.~~) The certificate can follow a certificate of competency holder to another employer provided that employer is currently licensed at the appropriate level.

[Statutory Authority: RCW 18.270.900 and 18.160.030. WSR 14-03-019, § 212-80-108, filed 1/7/14, effective 2/7/14. Statutory Authority: Chapters 43.43 and 18.160 RCW. WSR 05-05-006, amended and recodified as § 212-80-108, filed 2/4/05, effective 3/7/05. Statutory Authority: Chapters 43.63A and 18.160 RCW. WSR 94-24-032, § 212-80-060, filed 12/1/94, effective 1/1/95; WSR 91-14-086 (Order 91-06), § 212-80-060, filed 7/1/91, effective 8/1/91.]

AMENDATORY SECTION (Amending WSR 14-03-019, filed 1/7/14, effective 2/7/14)

WAC 212-80-113 Certificate of competency holder employment. (1) (~~What are the employment requirements for a certificate holder?~~) All certificate of competency holders must be employed by a licensed fire protection sprinkler system contractor.

(a) In no case will a certificate of competency holder be employed full time by more than one licensed contractor at the same time.

(b) If the certificate of competency holder should leave the employment of the licensed contractor, he or she will notify the director within (~~(thirty)~~) 30 days of his or her last day of employment. Failure to do so constitutes a Level 2 violation.

(2) (~~(Are there any exceptions to the employment requirements for a certificate holder? Yes.)~~) The following exceptions may apply:

(a) Any current certificate of competency holder for the license and certification year who is no longer employed by a licensed contractor will become "INACTIVE (~~(, "unless he or she is a journey, residential or trainee sprinkler fitter.)~~)." An "INACTIVE" certificate will:

(i) Not be issued a physical certificate;

(ii) Not allow the certificate of competency holder to perform any work in the fire protection sprinkler system trade as a certificate of competency holder until the certificate of competency holder is employed by a licensed contractor licensed by the director. When an "INACTIVE" certificate of competency holder is employed by a licensed contractor the director will reissue a certificate to the certificate of competency holder;

(iii) Expire at the end of the current licensing and certification cycle and cannot be renewed as "INACTIVE."

(b) The "QUALIFIED EXEMPT" certification allows persons who are considered exempt from the licensing (~~(or)~~) and certification requirements of chapter 18.160 RCW and this chapter and not currently working for a licensed contractor, to obtain evidence of qualification while working for an employer who requires a knowledge and skill base of fire protection sprinkler systems.

(i) A "QUALIFIED EXEMPT" certificate:

(A) Will not be used for work under contract.

(B) May be issued to:

(I) An employee of the United States, state or local government, building officials, fire marshals, fire inspectors, or insurance inspectors when acting in their official capacities.

(II) A person who performs maintenance or other duties for an employer, and performs work on only his or her employer's fire protection sprinkler system.

(III) A person who works for an industry ancillary to the fire protection sprinkler system contracting trade that is regulated by chapter 18.160 RCW.

(ii) A "QUALIFIED EXEMPT" certificate of competency holder will:

(A) Bear "QUALIFIED EXEMPT" on the certificate and listing post on the internet and the person's level of certification.

(B) Be issued a physical certificate.

(C) Not be issued a stamp.

[Statutory Authority: RCW 18.270.900 and 18.160.030. WSR 14-03-019, § 212-80-113, filed 1/7/14, effective 2/7/14. Statutory Authority: RCW 18.270.900. WSR 09-01-114, § 212-80-113, filed 12/19/08, effective 1/19/09. Statutory Authority: Chapters 43.43 and 18.160 RCW. WSR 05-17-099, § 212-80-113, filed 8/16/05, effective 9/16/05; WSR 05-05-006, amended and recodified as § 212-80-113, filed 2/4/05, effective 3/7/05. Statutory Authority: Chapters 43.63A and 18.160 RCW. WSR 91-14-086 (Order 91-06), § 212-80-070, filed 7/1/91, effective 8/1/91.]

AMENDATORY SECTION (Amending WSR 14-03-019, filed 1/7/14, effective 2/7/14)

WAC 212-80-118 Certificate renewals. (1) ~~((When are certificates required to be renewed?~~

~~(a-))~~ A certificate must be renewed by January 1st of each calendar year.

~~((b) Certificates for journey and residential fitters must be renewed by January 1st of every even-numbered year. A sprinkler fitter certificate holder will be sent a renewal form by the director to renew the certificate.~~

~~(c) Certificates for sprinkler fitter trainees must be renewed by January 1st of every even-numbered year.~~

~~(i) Trainees who have a current certificate will be sent a renewal form by the director to renew their certificate.~~

~~(ii) The certificate will not be renewed if the trainee is not currently employed by a licensed contractor.~~

~~(d) Failure of a trainee, journey, or residential sprinkler fitter to renew his or her certificate will result in him or her:~~

~~(i) Filing a new application with the director on a form provided by the director; and~~

~~(ii) Successfully passing the written examination required by this chapter.~~

~~(2) What happens if the certificate holder does not renew his or her application by the expiration date?)~~ (2) Failure of a certificate of competency holder to renew his or her certificate by the expiration date will constitute a break in certification. For certificates that are expired for:

(a) Less than two consecutive calendar years, the certificate of competency holder may ~~((renew))~~ reinstate by submitting a ~~((renewal))~~ reinstatement application provided by the director and paying applicable fees.

(b) Two or more calendar years, the certificate of competency holder must submit a new application with evidence of qualification, including any required exam, and applicable fees for a new certificate.

Those who were qualified under the grandfathering process will need to ~~((show evidence of qualification meeting))~~ apply for certification as a new applicant and meet the current requirements.

(3) ~~((Are there reasons why the director would not renew a certificate? Yes-))~~ The director will not renew a certificate if:

(a) The certificate of competency holder is employed by a fire protection sprinkler system contractor who has not submitted for a renewal of its license; or

(b) The certificate of competency holder is employed by an unlicensed fire protection sprinkler system contractor or anyone who is not otherwise considered exempt from chapter 18.160 RCW; or

(c) The certificate is in a revoked or suspended status.

[Statutory Authority: RCW 18.270.900 and 18.160.030. WSR 14-03-019, § 212-80-118, filed 1/7/14, effective 2/7/14. Statutory Authority: RCW 18.270.900. WSR 09-01-114, § 212-80-118, filed 12/19/08, effective 1/19/09. Statutory Authority: Chapters 43.43 and 18.160 RCW. WSR 05-05-006, amended and recodified as § 212-80-118, filed 2/4/05, effective 3/7/05. Statutory Authority: Chapters 43.63A and 18.160 RCW. WSR 91-14-086 (Order 91-06), § 212-80-075, filed 7/1/91, effective 8/1/91.]

AMENDATORY SECTION (Amending WSR 14-03-019, filed 1/7/14, effective 2/7/14)

WAC 212-80-123 Voluntary relinquishment of certificates. (1) A certificate of competency holder may voluntarily relinquish his or her certificate to the director.

(2) The relinquishment is effective when the certificate is received by the director.

(3) After relinquishing the certificate, he or she will not be known as a certificate of competency holder or trainee and will desist from the practice thereof.

(4) Within two years from the time of relinquishment of the certificate, he or she may again qualify for a certificate, with the approval of the director by submission of a (~~renewal~~) reinstatement application and the payment of (~~the~~) any required fee.

(5) If two or more years have elapsed, he or she will return to the status of a new applicant.

[Statutory Authority: RCW 18.270.900 and 18.160.030. WSR 14-03-019, § 212-80-123, filed 1/7/14, effective 2/7/14. Statutory Authority: RCW 18.270.900. WSR 09-01-114, § 212-80-123, filed 12/19/08, effective 1/19/09. Statutory Authority: Chapters 43.43 and 18.160 RCW. WSR 05-05-006, amended and recodified as § 212-80-123, filed 2/4/05, effective 3/7/05. Statutory Authority: Chapters 43.63A and 18.160 RCW. WSR 91-14-086 (Order 91-06), § 212-80-080, filed 7/1/91, effective 8/1/91.]

AMENDATORY SECTION (Amending WSR 14-03-019, filed 1/7/14, effective 2/7/14)

WAC 212-80-165 Certificate of competency holder requirements and limitations. (1) (~~Who is issued a wallet card?~~) The director issues a wallet card to a person issued a certificate of competency. The card will be kept by the certificate of competency holder. The certificate of competency holder must make the card available for review at any time.

(2) (~~Can the authority having jurisdiction or the director inspect the wallet cards? Yes.~~) The authority having jurisdiction or director may request a certificate of competency holder to display his or her wallet card. Failure to display a wallet card upon request constitutes a Level 1 violation.

[Statutory Authority: RCW 18.270.900 and 18.160.030. WSR 14-03-019, § 212-80-165, filed 1/7/14, effective 2/7/14. Statutory Authority: Chapters 43.43 and 18.160 RCW. WSR 05-17-099, § 212-80-165, filed 8/16/05, effective 9/16/05.]

AMENDATORY SECTION (Amending WSR 14-03-019, filed 1/7/14, effective 2/7/14)

WAC 212-80-205 Suspension or revocation of licenses or certificates. (1) (~~Who can suspend or revoke a license or certificate?~~) The director may refuse to issue or renew or may suspend or revoke the

privilege of a certificate of competency holder, or a licensed or unlicensed fire protection sprinkler system contractor to engage in the fire protection sprinkler system business. The director may establish penalties against a person who violates any provision of chapter 18.160 (~~(or 18.270)~~) RCW or any provision of this chapter while he or she is engaged in the design, installation, inspection, testing, maintenance, or repair, of a fire sprinkler system or any part of such system.

(2) (~~(What actions result in suspension, revocation or civil penalties against a fire protection sprinkler system contractor licensee or certificate holder?)~~) The following actions will result in suspension, revocation, or civil penalties against a fire protection sprinkler system contractor or certificate of competency holder:

(a) Gross incompetence - The licensed contractor or certificate of competency holder demonstrated he or she does not have the qualifications or ability to perform at the level of license or certificate required to contract or offer to bid on the design, installation, inspection, testing, maintenance, or repair, of a fire protection sprinkler system or any part of such system. For the purpose of this subsection, qualifications mean that the person did not possess or has not possessed a valid certificate to the level required for the work performed.

(b) Gross negligence - The licensed contractor or certificate of competency holder has demonstrated a habitual failure in the preparation of layout drawings, installation, repair, alteration, testing, maintenance, inspection, or addition to fire protection sprinkler systems in accordance with plans, specifications, building codes, or the publications of the National Fire Protection Association. For the purpose of this subsection, "habitual failure" means that the person has over a period of time committed five violations of chapter 18.160 (~~(or 18.270)~~) RCW, or this chapter in separate offenses, or has failed to design or install sprinkler systems in accordance with plans, specifications, building codes, or the publications of the National Fire Protection Association. Violations for gross negligence identified and enforced by the authority having jurisdiction must:

(i) Show a pattern of performance issues or repetitive violations of chapter 18.160 (~~(or 18.270)~~) RCW, or this chapter to the director;

(ii) Demonstrate that the pattern of performance issues or repetitive violations have occurred in any jurisdiction within the state of Washington beginning no more than five years from the date the authority having jurisdiction's investigation commences; and

(iii) Provide documentation to show the licensed contractor or certificate of competency holder's gross negligence including, but not limited to:

(A) Correspondence between the licensed contractor or certificate of competency holder and the local authority having jurisdiction that identifies violations of work that do not comply with the applicable standards;

(B) Failed permit or work inspections;

(C) Issued stop work order;

(D) Investigations resulting from a complaint;

(E) Violation notices; or

(F) Issued citations or infractions.

(c) Dishonest practices - The licensed contractor or the certificate of competency holder will not engage in dishonest fire protection sprinkler systems business practices that include, but are not limited to:

(i) Charging customers for work not performed. When a licensee is suspended, revoked, or denied, as part of a complaint investigation where the licensed contractor or certificate of competency holder received payment for supplies or work not performed and did not return the funds to the person contracting for the service, the director may upon receipt of a renewal application require that the licensed contractor or certificate of competency holder pay restitution as a condition to renew the license.

(ii) Receiving ~~((down))~~ any payments on work that the licensed contractor or the certificate of competency holder is not licensed or certified to perform.

(iii) Implying either verbally or in writing that either the licensed contractor or the certificate of competency holder possesses the appropriate license or certificate to bid on or complete fire sprinkler work when he or she does not have that fire protection sprinkler system contractor license or certification level.

(iv) Performing certification, installation, inspection, testing, or maintenance for a water based fire protection sprinkler system or equipment contrary to the National Fire Protection Association codes, National Fire Protection Association standards, or manufacturer's specifications.

(v) Performing certification, installation, inspection, testing, or maintenance for a water based fire protection sprinkler system or equipment beyond that which the contractor is licensed or certificate of competency holder is certified, regardless of whether or not the work done was in compliance with the National Fire Protection Association codes, National Fire Protection Association standards, or manufacturer's specifications.

(d) Actions showing an indifference to comply with the fire protection sprinkler system business practices that include, but are not limited to a licensed contractor:

(i) Offering to contract for fire protection sprinkler system work without currently employing a certificate of competency holder.

(ii) Requiring or allowing employees to falsify any sprinkler tags, labels, or inspection reports.

(iii) Permitting or requiring a certificate of competency holder to use his or her certificate in connection with the preparation of any technical drawings that have not been prepared personally by the certificate of competency holder or under his or her direct supervision, or in violation of this chapter.

(e) Any violation of this section constitutes a Level 3 violation.

(3) ~~((Will a licensed contractor or certificate holder be notified if action is taken against their license or certification? Yes.))~~ The licensed contractor or certificate of competency holder will be notified in writing of the denial, suspension, or revocation action.

(4) ~~((What is the process for the director to deny, suspend, or revoke a license or certificate?))~~ The director may deny, suspend, or revoke a license or certificate under the following process:

(a) The director must give the licensed contractor or certificate of competency holder notice of the action and an opportunity to be heard as prescribed in chapter 34.05 RCW before the denial, suspension, or revocation of the license or certificate.

(b) Upon receiving notice of the denial, suspension, or revocation action, the licensed contractor or certificate of competency holder may, within ~~((thirty))~~ 30 days from the date of the notice of action, request in writing to the director a hearing on the denial,

suspension, or revocation of the license or certificate. An adjudicative proceeding will be commenced within ((nintety)) 90 days of the receipt of a hearing request. Failure to request a hearing, or failure to appear at a requested hearing, a prehearing conference, or any other stage of an adjudicative proceeding, will constitute default and may result in the entry of a final order under RCW 34.05.440.

(c) Upon receiving a hearing request, the director may, at the request of the licensed contractor or certificate of competency holder, or on his or her own initiative, schedule an informal settlement conference which will be without prejudice to the rights of the parties. The informal settlement conference will be held in Thurston County at a mutually agreed upon time and may result in a settlement agreement. If no agreement is reached, a hearing will be scheduled as outlined in chapter 34.05 RCW.

(d) The director may, without prior notification to the licensed contractor or certificate of competency holder, deny, suspend, or revoke a license or certificate if the director finds that there is a danger to the public health, safety, or welfare that requires immediate action. In every summary suspension of a license or certificate, an order signed by the director or designee must be entered, in compliance with the provisions of RCW 34.05.479. Administrative proceedings consistent with chapter 34.05 RCW for revocation or other action shall be promptly instated and determined. The director must give notice as is practicable to the licensed contractor or certificate of competency holder.

(5) (~~What are the penalties associated with performing fire protection sprinkler system work while a license or certificate is denied, suspended, or revoked?~~) The following penalties are associated with performing fire protection sprinkler system work while a license or certificate is denied, suspended, or revoked:

(a) Any person engaged in the trade of designing, installing, inspecting, testing, maintaining, or repairing a fire protection sprinkler systems or any part of such system while his or her license or certificate is denied, suspended, or revoked, will be issued a Level 3 violation.

(b) Any licensed or unlicensed fire protection sprinkler system contractor that allows an employee or trainee to engage in the trade designing, installing, inspecting, testing, maintaining, or repairing a fire protection sprinkler system or any part of such a system while his or her license or certificate has been denied, suspended, or revoked, will be issued a Level ((three)) 3 violation.

[Statutory Authority: RCW 18.270.900 and 18.160.030. WSR 14-03-019, § 212-80-205, filed 1/7/14, effective 2/7/14. Statutory Authority: RCW 18.270.900. WSR 09-01-114, § 212-80-205, filed 12/19/08, effective 1/19/09. Statutory Authority: Chapters 43.43 and 18.160 RCW. WSR 05-17-099, § 212-80-205, filed 8/16/05, effective 9/16/05; WSR 05-05-006, amended and recodified as § 212-80-205, filed 2/4/05, effective 3/7/05. Statutory Authority: Chapters 43.63A and 18.160 RCW. WSR 94-24-032, § 212-80-065, filed 12/1/94, effective 1/1/95; WSR 92-20-070 (Order 92-08), § 212-80-065, filed 10/5/92, effective 11/5/92; WSR 91-14-086 (Order 91-06), § 212-80-065, filed 7/1/91, effective 8/1/91.]

AMENDATORY SECTION (Amending WSR 14-03-019, filed 1/7/14, effective 2/7/14)

WAC 212-80-210 Imposing citations and civil penalties. (1)

~~((Who may issue civil penalties or citations?))~~ The director may impose civil penalties or fines to any licensed contractor or certificate of competency holder that violates any provision of chapter 18.160 ~~((or 18.270))~~ RCW, or this chapter. The director may impose the civil penalties or fines listed herein to any unlicensed contractor or uncertified person who operates in the state of Washington as a licensed fire protection sprinkler system contractor or certificate of competency holder. The director will record all violations.

(2) ~~((When may civil penalties or citations be issued?))~~ The director may issue a citation when an investigation verifies that the fire protection sprinkler system contractor or certificate of competency holder was not in compliance with or otherwise in violation of chapter 18.160 ~~((or 18.270))~~ RCW, or this chapter.

(3) ~~((What is a violation?))~~ A violation is an action by a person who engages in the design, installation, inspection, testing, maintenance, or repair of a fire protection sprinkler system or any part of such a system, and fails to comply with chapter 18.160 ~~((or 18.270))~~ RCW, or this chapter.

(4) ~~((Is there a statute of limitations for a violation?))~~ The director must take action on a license or certificate within five years after the violation is reported to the director.

[Statutory Authority: RCW 18.270.900 and 18.160.030. WSR 14-03-019, § 212-80-210, filed 1/7/14, effective 2/7/14. Statutory Authority: RCW 18.270.900. WSR 09-01-114, § 212-80-210, filed 12/19/08, effective 1/19/09. Statutory Authority: Chapters 43.43 and 18.160 RCW. WSR 05-05-006, § 212-80-210, filed 2/4/05, effective 3/7/05.]

AMENDATORY SECTION (Amending WSR 14-03-019, filed 1/7/14, effective 2/7/14)

WAC 212-80-215 Citations and penalties. (1) ~~((What citation or penalties may be issued by the director for violations?))~~ The director may at his or her discretion issue either a monetary penalty or take an action against a license or certificate depending on the severity of the violation(s) evidenced in the investigation. Each violation is classified and penalties assessed according to the violation type as provided by the chart below:

Violation Level	Monetary Penalty Issued	Action Taken Against License and/or Certificate
1	Warning to ((200)) \$500	License: No action
		Certificate: No action

Violation Level	Monetary Penalty Issued	Action Taken Against License and/or Certificate
2	(((\$100 to \$500)) \$500 to \$1,000	License: Suspended immediately for remainder of the license year or ((thirty) 30) calendar days, whichever is longer.
		Certificate: Suspended immediately for remainder of the license year or ((thirty) 30) calendar days, whichever is longer.
		Certificate: If the individual is not part of the violation but will be affected by the loss of the employer's contractor license, the certificate will be changed to INACTIVE status until the contractor obtains a valid license or the certificate of competency holder has a new employer.
3	(((\$500 to \$5,000)) \$1,000 to \$5,000	License: Suspended immediately for remainder of the license year or ((ninety) 90) calendar days, whichever is longer.
		Certificate: Suspended immediately for remainder of the license year or ((ninety) 90) calendar days, whichever is longer.
		Certificate: If individual is not part of the violation but will be affected by the loss of the employer's contractor license, the certificate will be changed to INACTIVE status until the contractor obtains a valid license or the certificate of competency holder has a new employer.

(2) (~~What action can be taken against a licensed contractor or certificate holder for repeat violations?~~) If a licensed contractor or certificate of competency holder has incurred multiple findings of the same violation over a period of time, the director may classify the licensed contractor or certificate of competency holder as a habitual offender and issue either an increased monetary penalty or the action against the license or certificate depending on the severity of the violation(s) evidenced in multiple investigations as provided by the chart below:

Violation Level	Monetary Penalty Issued	Violation Level and Action Taken Against License and/or Certificate
1	(((\$100 to \$500)) \$1,000	Evidence of three or more Level 1 violations without compliance over a period of two calendar years constitutes an increase to a Level 2 violation.

Violation Level	Monetary Penalty Issued	Violation Level and Action Taken Against License and/or Certificate
2	(((\$500)) <u>\$2,500</u> per violation	Evidence of three or more <u>Level 2</u> violations without compliance over a period of two calendar years constitutes an increase to a <u>Level 3</u> violation. License: Suspended immediately for remainder of the license year or ((sixty)) <u>60</u> calendar days, whichever is longer. Certificate: Suspended immediately for remainder of the license year or ((sixty)) <u>60</u> calendar days, whichever is longer. Certificate: If individual is not part of the violation but will be affected by the loss of the employer's contractor license, the certificate will be changed to INACTIVE status until the contractor obtains a valid license or the certificate of competency holder has a new employer.
3	(((\$2,500)) <u>\$5,000</u> per violation	Evidence of two ((to five)) <u>or more</u> violations without compliance over a period of three calendar years constitutes an increase to a <u>Level 3</u> violation. License: Suspended immediately for remainder of the license year or ((one hundred eighty)) <u>180</u> calendar days, whichever is longer. Certificate: Suspended immediately for remainder of the license year or ((one hundred eighty)) <u>180</u> calendar days, whichever is longer. Certificate: If individual is not part of the violation but will be affected by the loss of the employer's contractor license, the certificate will be changed to INACTIVE status until the contractor obtains a valid license or the certificate of competency holder has a new employer.
	(((\$5,000 per violation	Evidence of six violations without compliance over a period of three calendar years constitutes an increase to a <u>level 3</u> violation. License: Suspended immediately for the remainder of the license year and subsequent license year. Certificate: Suspended immediately for the remainder of the certificate year and subsequent certificate year. Certificate: If individual is not part of the violation but will be affected by the loss of the employer's contractor license, the certificate will be changed to INACTIVE status until the contractor obtains a valid license or the certificate holder has a new employer.))

~~(3) ((If I receive a violation notice imposing a civil penalty, how do I resolve the civil penalty?))~~ Level 1 violations include, but are not limited to:

(a) Failing to inform the director of the loss of their primary certificate of competency holder, as required by RCW 18.160.040.

(b) Failing to have the certificate of competency holder stamp plans, calculations, and/or test certificates.

(c) Allowing an employee to certify, install, inspect, maintain, and/or service water-based fire sprinkler systems or equipment contrary to NFPA codes, standards, or manufacturers' specifications without specific written permission from the location authority having jurisdiction.

(d) Working without a permit, or permission to do so, by the local authority having jurisdiction.

(4) Level 2 violations include, but are not limited to:

(a) Performing work on a sprinkler system where the employee's certificate of competency holder under RCW 18.160.040 does not have a current or valid license.

(b) Working without the appropriate level of license or certificate of competency.

(c) Permitting his or her license to be used in connection with the preparation of any technical drawings that have not been prepared by him or her personally, or under their direct supervision.

(d) Working with an expired license or permit (more than 90 days).

(5) Level 3 violations include, but are not limited to:

(a) Demonstrating gross incompetency or gross negligence in the preparation of technical drawings, the installation, inspection, testing, maintenance, repair, alteration, service, and/or addition to a fire sprinkler system.

(b) Allowing an employee to demonstrate gross incompetency or gross negligence in the installation, inspection, testing, maintenance, repair, alteration, service and/or addition to a fire sprinkler system.

(c) Charging a customer for fire sprinkler work not performed.

(d) Offering to contract for fire sprinkler work without a certificate of competency holder, as described in RCW 18.160.040.

(e) Allowing an employee to falsify any fire sprinkler tags, labels, or inspection reports.

(f) Working without a certified full-time certificate of competency holder on staff, or, in the case of an inspection and testing contractor, allowing any employee not certified by the chief of the Washington state patrol, through the director of fire protection, as an inspection and testing technician.

(g) Falsifying an application or document submitted to the chief of the Washington state patrol, through the director of fire protection, to obtain a sprinkler contractor license or certificate of competency.

(h) Committing three or more level II offenses within a three year period either as a company, through an employee of the company, through an employee acting as a certificate of competency holder for the company, and/or any combination thereof.

(i) Permitting his or her license to be used in connection with the stamping of any test certificates for work performed by someone other than his or her full-time employees.

(6) Civil penalties shall be resolved through the following:

(a) **Pay the penalty** by returning the notice and payment to the director at State Fire Marshal's Office, P.O. Box ((42600)) 42642, Olympia, WA 98504-((2600)) 2642 within ((~~thirty~~)) 30 days from the date the penalty was issued. Payments must be made by check or money order payable to the Washington state patrol.

(b) **Request an informal conference** as outlined in WAC 212-80-235.

(c) **Request a formal hearing** as outlined in WAC 212-80-205 or 212-80-240.

[Statutory Authority: RCW 18.270.900 and 18.160.030. WSR 14-03-019, § 212-80-215, filed 1/7/14, effective 2/7/14. Statutory Authority: RCW 18.270.900. WSR 09-01-114, § 212-80-215, filed 12/19/08, effective 1/19/09. Statutory Authority: Chapters 43.43 and 18.160 RCW. WSR 05-05-006, § 212-80-215, filed 2/4/05, effective 3/7/05.]

AMENDATORY SECTION (Amending WSR 14-03-019, filed 1/7/14, effective 2/7/14)

WAC 212-80-245 Penalty adjustments. (1) (~~((Can a penalty be adjusted without an informal or formal hearing?))~~) The assessment of adjustment of penalties for amounts other than those set by chapter 18.160 (~~(or 18.270)~~) RCW will be done only by the director through a hearings process either formally or informally.

(2) (~~((What factors are considered for assessing penalties?))~~) The assessment of penalties for not being in conformance with chapter 18.160 (~~(or 18.270)~~) RCW, or this chapter may be made only after considering:

- (a) The gravity and magnitude of the violation.
- (b) The person's previous record.
- (c) Such other considerations as the director may consider appropriate.
- (d) The uniformity and consistency in the application of violations or penalties statewide.

[Statutory Authority: RCW 18.270.900 and 18.160.030. WSR 14-03-019, § 212-80-245, filed 1/7/14, effective 2/7/14. Statutory Authority: RCW 18.270.900. WSR 09-01-114, § 212-80-245, filed 12/19/08, effective 1/19/09. Statutory Authority: Chapters 43.43 and 18.160 RCW. WSR 05-05-006, § 212-80-245, filed 2/4/05, effective 3/7/05.]

AMENDATORY SECTION (Amending WSR 14-03-019, filed 1/7/14, effective 2/7/14)

WAC 212-80-250 Payment of civil penalty. (1) (~~((How can payments be made?))~~) The penalty must be paid to the director within (~~(thirty)~~) 30 days after an order assessing a civil penalty becomes final by operation of law or on an appeal.

(2) (~~((Can payments in installments be made to resolve civil penalties?))~~) A request can be made through an informal or formal conference to make installment payments on a civil penalty. If the mitigation officer authorizes installment payments during an informal or formal hearing, the payment plan will be developed and agreed upon at the hearing. Failure to comply with the payment plan will void the payment plan and the remaining balance must be paid by the next business day.

(3) (~~((What happens if I fail to pay the civil penalty?))~~) If the licensed contractor or certificate of competency holder fails to pay the full penalty or comply with the payment plan as provided by subsection (2) of this section:

(a) The license or certificate of competency will be revoked for the remainder of the current license or certificate year and will not be reinstated or renewed until the penalty is paid in full.

(b) The attorney general may bring an action in the name of the director in the superior court of Thurston County or of any county in which the violator may do business to collect any penalty imposed under chapter 18.160 (~~or 18.270~~) RCW.

[Statutory Authority: RCW 18.270.900 and 18.160.030. WSR 14-03-019, § 212-80-250, filed 1/7/14, effective 2/7/14. Statutory Authority: RCW 18.270.900. WSR 09-01-114, § 212-80-250, filed 12/19/08, effective 1/19/09. Statutory Authority: Chapters 43.43 and 18.160 RCW. WSR 05-05-006, § 212-80-250, filed 2/4/05, effective 3/7/05.]

OTS-4052.2

**Chapter 212-90 WAC
FIRE PROTECTION SPRINKLER FITTING**

GENERAL PROVISIONS

NEW SECTION

WAC 212-90-001 Purpose. The purpose of this chapter is to adopt rules to a single statewide standard of performance and compliance for the issuance of certificates to sprinkler fitters, and the issuance of civil fines for violations of any provision of chapter 18.270 RCW or any provision of this chapter.

[]

NEW SECTION

WAC 212-90-005 Applicability. This chapter applies to any person performing as a fire protection sprinkler system contractor or certificate holder as defined in chapter 18.270 RCW.

[]

NEW SECTION

WAC 212-90-010 Definitions. The following definitions will apply throughout this chapter:

(1) "Authority having jurisdiction (AHJ)" means the organization, office, or individual responsible for issuing permits, approving layout drawings, enforcing the requirements of a code or standard or approving materials, an installation, or a procedure. Usually, the AHJ is the building or fire official of the city or county in which the job site is located. In certain cases, such as health care facilities, transient accommodations, and day care facilities, the AHJ is the city or county building or fire official and the director.

(2) "Certificate" means a certificate granted by the director under chapter 18.270 RCW, and is valid within the state and all political subdivisions, and meets all of the requirements for certification that may be applied by the political subdivision.

(3) "Citation" means written notification issued by the director pursuant to RCW 18.270.020 of a civil penalty for a violation of any provision of chapter 18.270 RCW or this chapter. A citation may include, but is not limited to, a description of the violation(s) and a notice of civil penalty assessment.

(4) "Contractor" means any person that submits a bid or offers to contract for the design, installation, inspection, testing, maintenance, or repair of a fire protection sprinkler system or any part of such system under chapter 18.160 RCW.

(5) "Direct supervision" means the person providing direction, oversight, inspection, and observation of the work performed on the installation, maintenance, alteration, or repair of a fire protection sprinkler system. Supervision requirements are met when the supervisor is on the premises for the duration of the working day.

(6) "Director" means the chief of the Washington state patrol through the director of fire protection or his or her designee.

(7) "Fire protection sprinkler system" means an assembly of underground or overhead piping beginning at the connection to the primary water supply, whether public or private, that conveys water with or without other agents to dispersal openings or devices to extinguish, control, or contain fire or other products of combustion.

(8) "Formal hearing" means a hearing before a hearings officer where laws, rules, and evidence are presented, considered, and a decision is rendered.

(9) "Hazard" means a condition which could result in injury or death to a person or damage to property.

(10) "Hearings request" means the written request for a formal hearing to contest a civil penalty.

(11) "Licensed contractor" means a contractor issued a license to perform fire protection sprinkler system work by the director pursuant to WAC 212-90-053.

(12) "Maintenance" means work performed to keep the equipment operable in water-based fire protection systems.

(13) "Mitigation or hearing officer" is the state fire marshal or his or her designee who will preside over an informal, mitigation conference to discuss a civil penalty that has been assessed against a person for a violation of this chapter.

(14) "NFPA" means the National Fire Protection Association. The following national standards adopted by the NFPA apply to fire sprinkler suppression systems:

- (a) "NFPA 13D" means, in addition to the definition contained in chapter 18.160 RCW, the inclusion of minor accessory uses such as garages normally found in residential occupancies.
- (b) "NFPA 13R" means the installation and design of fire suppression sprinkler systems in residential occupancies up to and including four stories in height in buildings not exceeding 60 ft (18 m) in height above grade plane.
- (c) "NFPA 13" means the installation and design of fire suppression sprinkler systems in commercial or high occupancy facilities.
- (d) "NFPA 14" means the installation of standpipe and hose systems.
- (e) "NFPA 15" means the standard for water spray fixed systems.
- (f) "NFPA 16" means the standard for the installation of foam-water sprinkler and foam-water spray systems.
- (g) "NFPA 20" means the selection and installation of pumps, both centrifugal and positive displacement, that supply liquid for a private fire protection system.
- (h) "NFPA 24" means the installation of the dedicated underground fire service main of a water-based fire protection system.
- (i) "NFPA 25" means the inspection, testing, and maintenance of water-based fire protection systems.
- (15) Multipurpose piping sprinkler system: A piping system intended to serve both domestic needs in excess of a single fixture and fire protection needs from one common piping system throughout the dwelling unit(s).
- (16) Network sprinkler system: A type of multipurpose system utilizing a common piping system supplying domestic fixtures and fire sprinklers where each sprinkler is supplied by a minimum of three separate paths.
- (17) Passive purge system: A type of sprinkler system that serves a single toilet in addition to the fire sprinklers.
- (18) Stand-alone sprinkler system: A sprinkler system where the above ground piping serves only fire sprinklers.
- (19) Antifreeze sprinkler system: A wet pipe system using automatic sprinklers that contains a liquid solution to prevent freezing of the system, and is intended to discharge the solution upon sprinkler operation, followed immediately by water from a water supply.
- (20) "Person" means one or more individuals, legal representatives, partnerships, joint ventures, associations, corporations (whether or not organized for profit), business trusts, or any organized group of individuals and includes the state, state agencies, counties, municipal corporations, school districts, and other public corporations.
- (21) "Qualified" means an individual who has demonstrated through education, training, examination, or national certifications the competency, skill, and ability necessary to perform any work covered or defined by chapter 18.270 RCW to the satisfaction of a relevant jurisdiction. In matters of compliance with the licensing and certification requirements of this chapter and chapter 18.270 RCW, the relevant jurisdiction shall be the director.
- (22) "Repair" means to restore by replacing a part of or putting together what is deficient or broken on the fire protection sprinkler system.
- (23) "Revoke" means the director will rescind a company's license or an individual's certificate. This action causes the company or individual to cease any work in the fire protection sprinkler system field in Washington state.

(24) "Suspend" means the director holds a company's license or individual's certificate inactive until such time as the director determines that the company or individual is in compliance with the requirements of this chapter and chapter 18.270 RCW.

(25) "Trainee" means a person who:

(a) Has been issued a training certificate by the director; and

(b) Is learning the fire protection sprinkler fitting trade under the supervision of a journey-level sprinkler fitter or residential sprinkler fitter working in his or her specialty.

(26) "Violation" means any action, general or specific, inconsistent with the intent and letter of chapter 18.270 RCW and shall be further defined as:

(a) "Level 1 violation" means a violation which poses a minimal hazard or threat to life and property in the event of a fire.

(b) "Level 2 violation" means a violation which poses a significant hazard or threat to life or property in the event of a fire.

(c) "Level 3 violation" means a violation which poses a substantial hazard or threat to life or property in the event of a fire.

[]

NEW SECTION

WAC 212-90-015 Compliance. All fire protection sprinkler system contractors, fitter certificate holders, or trainees, who install, alter, or repair, fire protection sprinkler systems or any part of such a system will comply with the provisions of this chapter.

Exceptions:

(1) A person issued a certificate of competency by the Washington state department of labor and industries, under chapter 18.106 RCW, as a journey-level or residential specialty plumber or supervised plumber trainee installing a residential network fire protection sprinkler system connected to potable water who works for a contractor as defined by WAC 212-90-010(4) of this chapter.

(2) A person who inspects, field tests, maintains, or repairs backflow prevention assemblies installed on potable water supplies to fire sprinkler systems and who is certified as a:

(a) Backflow assembly tester by the Washington state department of health, under chapters 70A.120 RCW and 246-292 WAC; or

(b) Backflow specialty plumber by the Washington state department of labor and industries, under chapters 18.106 RCW and 296-400A WAC, when repairing backflow prevention assemblies within a building.

[]

NEW SECTION

WAC 212-90-018 Certification requirements. Sprinkler fitter certifications - The following levels will apply to sprinkler fitter certifications issued by the director:

(1) **Journey-level sprinkler fitter certification** - Installs, dismantles, alters, maintains, repairs, and corrects all types of sprinkler, standpipe, hose, or other hazard systems for fire protection

purposes that are an assembly of piping, conduit, tubing, or hose regardless of the material composition beginning at the connection to the primary water supply. Also includes sprinkler tank heater, air lines tanks, pumps, equipment, appurtenances and all other related components attached thereto inside.

(2) **Residential-level sprinkler fitter certification** - Limited to installation, maintenance, and repair of the fire protection sprinkler system of residential occupancies as defined by NFPA 13D and NFPA 13R. A residential level sprinkler fitter certification may also perform installation and repair of NFPA 13 fire protection sprinkler systems and components while under the direct supervision of a certified journey-level sprinkler fitter.

(3) **Trainee-level sprinkler fitter certification** - Limited to performing sprinkler fitter work under the direct supervision of a sprinkler fitter certified to perform the type of work the trainee-level sprinkler fitter is performing.

Chart 1: Sprinkler Fitter Certifications

Level of Certificate Holder - See Note (1)	Standard Defining Work That May Be Performed				
	NFPA 13D	NFPA 13R	NFPA 13	NFPA 24	NFPA 25
Journey-Level Sprinkler Fitter	Yes	Yes	Yes	No	No
Residential-Level Sprinkler Fitter	Yes	Yes	Only if under the direct supervision of a journey-level sprinkler fitter	No	No
Trainee-Level Sprinkler Fitter	Only if under the direct supervision of a residential/ journey-level sprinkler fitter	Only if under the direct supervision of a residential/ journey-level sprinkler fitter	Only if under the direct supervision of a journey-level sprinkler fitter	No	No

[]

NEW SECTION

WAC 212-90-038 Municipality, county, or state regulations. (1) Licensed contractors and certificate holders must comply with the authority having jurisdiction's requirements to obtain permits or permission before the installation, repair, alteration, or addition of a fire protection sprinkler system. Failure to comply with this section constitutes a Level 2 violation.

(2) The licensed contractor or certificate holder must verify whether a permit or permission is required from the authority having jurisdiction before installing, repairing, altering, adding, or removing any fire protection sprinkler system.

[]

FIRE SPRINKLER FITTER CERTIFICATE HOLDER

NEW SECTION

WAC 212-90-093 Fitter certificate holder certification. (1) All applications must be made on the forms provided by the director and include the required fees provided by WAC 212-90-098 and documentation for the required level of experience as provided by this section.

(a) **For journey-level sprinkler fitter certification,** the applicant must:

(i) Provide evidence on the forms provided by the director of at least 8,000 hours of trade related fire protection sprinkler system experience in installation, alteration, and repair;

(ii) Not have more than 3,000 hours of the required 8,000 hours of experience in residential sprinkler fitting; and

(iii) Satisfactorily pass an examination provided by the director with a final score of 80 percent.

(b) **For residential sprinkler fitter certification,** the applicant must:

(i) Provide evidence on the forms provided by the director, of at least 4,000 hours of trade related fire protection sprinkler system experience in installation, repair, and maintenance; and

(ii) Satisfactorily pass an examination provided by the director with a final score of 80 percent.

(c) **For trainee sprinkler fitter certification,** the applicant must:

(i) Provide evidence to the director, on the forms provided by the director, of trade related employment by a licensed contractor;

(ii) Remain employed by a licensed contractor to maintain trainee status; and

(iii) Only engage in the fire protection sprinkler system trade when under the supervision of a certified journey level or residential installer.

Certificate Level	Application Required	Exam Required	Type of Work Performed by Certificate Holder
Journey Sprinkler Fitter	Yes	Pass an exam (See WAC 212-90-093)	Installs and repairs NFPA 13D, 13R, or 13 fire sprinkler systems
Residential Sprinkler Fitter	Yes	Pass an exam (See WAC 212-90-093)	Installs, repairs, and performs maintenance on fire sprinkler systems in residential occupancies
Trainee Sprinkler Fitter	Yes	No	Installs, repairs, and performs maintenance on a fire sprinkler system only under the supervision of a properly certified residential/journey level fitter

(2) All information submitted by an applicant to the director to apply for a certificate must be true and accurate. If the director

finds that information or documents submitted by an applicant is false, misleading, or has been altered in an effort to meet the requirements provided by this chapter, the finding will constitute a Level 3 violation.

(3) A violation of this section that involves a contractor allowing an employee to engage in performing fire protection sprinkler fitting work:

(a) By engaging in the trade of fire sprinkler fitting without having a valid sprinkler fitter certificate of competency issued for the work being conducted is a Level 3 violation.

(b) By a trainee sprinkler fitter engaging in the trade of fire sprinkler fitting without the direct supervision of a certified residential or journey sprinkler fitter is a Level 3 violation.

(c) As a trainee without a trainee certificate but with the direct supervision of a certified residential or journey sprinkler fitter is a Level 1 violation.

(d) Any individual using a certification and/or certification number not issued to them by the director.

[]

NEW SECTION

WAC 212-90-098 Fees for certificate holder. There are three separate fees that may apply:

(1) **Application fee** is \$100 only charged once when a person makes the initial application for any of the certificates specified in this section. As long as the certificate holder maintains continuous certification, the certificate holder is not required to pay a subsequent application fee. Application fees are nonrefundable.

(2) **Biennial certification fee** is \$200 paid each odd calendar year the certificate holder applies for certification renewal. The bi-annual renewal fee:

(a) Is in addition to the initial application fee paid for the initial application;

(b) Is nonrefundable once the certificate has been issued;

(c) Trainee sprinkler fitter certifications are exempt from the biennial certification fee.

(3) **Examination fee** is \$150, charged per examination, including retests. Examination fees are nonrefundable.

[]

NEW SECTION

WAC 212-90-108 Certificate not transferable. A certificate issued under this regulation is not transferable to another person.

[]

NEW SECTION

WAC 212-90-113 Certificate holder employment. If the certificate holder should leave the employment of the licensed contractor, he or she will notify the director within 30 days of his or her last day of employment. Failure to do so constitutes a Level 1 violation.

[]

NEW SECTION

WAC 212-90-118 Certificate renewals. (1) Certificates for journey, residential, and trainee fitters must be renewed by January 1st of every odd-numbered year. A sprinkler fitter certificate holder will be provided a renewal form by the director to renew the certificate.

For trainees, the certificate will not be renewed if the trainee is not currently employed by a licensed contractor.

(2) Failure of any fitter certificate holder to renew his or her certificate by the expiration date will constitute a break in certification.

(a) For residential and journey level fitters expired less than two consecutive calendar years, the certificate holder may reinstate by submitting a reinstatement application provided by the director, passing a certification exam, and pay all applicable fees.

(b) For residential and journey level fitters expired two or more calendar years, the certificate holder must submit a new application with evidence of qualification, pass a certification exam, and pay all applicable fees.

(c) For trainee level fitters expired for any period of time the certificate holder must complete the initial application form and pay the applicable fees.

(d) Those who were qualified under the grandfathering process must complete the applicable initial application process meeting the current requirements.

(3) The director will not renew a certificate if the certificate is in a revoked or suspended status.

[]

NEW SECTION

WAC 212-90-165 Fitter certificate holder requirements and limitations. (1) The director issues a wallet card to a person issued a sprinkler fitter certificate. The card will be kept by the sprinkler fitter certificate holder. The certificate holder must make the card available for review at any time.

(2) The wallet card must either be on the certificate holder (wallet, lanyard, article of clothing, etc.,) or readily accessible.

(3) Failure to comply with this section constitutes a Level 1 violation.

[]

ENFORCEMENT AND COMPLIANCENEW SECTION

WAC 212-90-205 Suspension or revocation of licenses or certificates. (1) The director may refuse to issue or renew or may suspend or revoke the privilege of a certificate holder, or a licensed or unlicensed fire protection sprinkler system contractor to engage in the fire protection sprinkler system business. The director may establish penalties against a person who violates any provision of chapter 18.270 RCW or any provision of this chapter while he or she is engaged in the trade of sprinkler fitting.

(2) The licensed contractor or certificate holder will be notified in writing of the denial, suspension, or revocation action.

(3) The director may deny, suspend, or revoke a license or certificate under the following process:

(a) The director must give the licensed contractor or certificate holder notice of the action and an opportunity to be heard as prescribed in chapter 34.05 RCW before the denial, suspension, or revocation of the license or certificate.

(b) Upon receiving notice of the denial, suspension, or revocation action, the licensed contractor or certificate holder may, within 30 days from the date of the notice of action, request in writing to the director a hearing on the denial, suspension, or revocation of the license or certificate. An adjudicative proceeding will be commenced within 90 days of the receipt of a hearing request. Failure to request a hearing, or failure to appear at a requested hearing, a prehearing conference, or any other stage of an adjudicative proceeding, will constitute default and may result in the entry of a final order under RCW 34.05.440.

(c) Upon receiving a hearing request, the director may, at the request of the licensed contractor or certificate holder, or on his or her own initiative, schedule an informal settlement conference which will be without prejudice to the rights of the parties. The informal settlement conference will be held in Thurston County at a mutually agreed upon time and may result in a settlement agreement. If no agreement is reached, a hearing will be scheduled as outlined in chapter 34.05 RCW.

(d) The director may, without prior notification to the licensed contractor or certificate holder, deny, suspend, or revoke a license or certificate if the director finds that there is a danger to the public health, safety, or welfare that requires immediate action. In every summary suspension of a license or certificate, an order signed by the director or designee must be entered, in compliance with the provisions of RCW 34.05.479. Administrative proceedings consistent with chapter 34.05 RCW for revocation or other action shall be promptly instated and determined. The director must give notice as is practicable to the licensed contractor or certificate holder.

(4) The following penalties are associated with performing fire protection sprinkler system work while a certificate is denied, suspended, or revoked:

(a) Any person engaged in the trade of sprinkler fitting while his or her license or certificate is denied, suspended, or revoked, will be issued a Level 3 violation.

(b) Any licensed or unlicensed fire protection sprinkler system contractor that allows an employee or trainee to engage in the trade of sprinkler fitting while his or her license or certificate has been denied, suspended, or revoked, will be issued a Level 3 violation.

[]

NEW SECTION

WAC 212-90-210 Imposing citations and civil penalties. (1) The director may impose civil penalties or fines to any licensed contractor, certificate holder, or individual that violates any provision of chapter 18.270 RCW, or this chapter. The director may impose the civil penalties or fines listed herein to any uncertified person who operates in the state of Washington as certificate holder. The director will record all violations.

(2) A violation is an action by a person who engages in the installation, maintenance, alteration, or repair of a fire protection sprinkler system or any part of such a system, and fails to comply with chapter 18.270 RCW, or this chapter.

[]

NEW SECTION

WAC 212-90-215 Citations and penalties. (1) The director may at his or her discretion issue either a monetary penalty or take an action against a license or certificate depending on the severity of the violation(s) evidenced in the investigation. Each violation is classified and penalties assessed according to the violation type as provided by the chart below:

Violation Level	Monetary Penalty Issued	Action Taken Against License and/or Certificate
1	Warning to \$200	License: No action.
		Certificate: No action.

Violation Level	Monetary Penalty Issued	Action Taken Against License and/or Certificate
2	\$100 to \$500	License: Suspended immediately for remainder of the license year or 30 calendar days, whichever is longer.
		Certificate: Suspended immediately for remainder of the license year or 30 calendar days, whichever is longer.
		Certificate: If the individual is not part of the violation but will be affected by the loss of the employer's contractor license, the certificate will be changed to INACTIVE status until the contractor obtains a valid license or the certificate holder has a new employer.
3	\$500 to \$5,000	License: Suspended immediately for remainder of the license year or 90 calendar days, whichever is longer.
		Certificate: Suspended immediately for remainder of the license year or 90 calendar days, whichever is longer.
		Certificate: If the individual is not part of the violation but will be affected by the loss of the employer's contractor license, the certificate will be changed to INACTIVE status until the contractor obtains a valid license or the certificate holder has a new employer.

(2) If a licensed contractor or certificate holder has incurred multiple findings of the same violation over a period of time, the director may classify the licensed contractor or certificate holder as a habitual offender and issue either an increased monetary penalty or the action against the license or certificate depending on the severity of the violation(s) evidenced in multiple investigations as provided by the chart below:

Violation Level	Monetary Penalty Issued	Violation Level and Action Taken Against License and/or Certificate
1	\$500	Evidence of three or more Level 1 violations without compliance over a period of two calendar years constitutes an increase to a Level 2 violation.

Violation Level	Monetary Penalty Issued	Violation Level and Action Taken Against License and/or Certificate
2	\$1,500 per violation	Evidence of three or more Level 2 violations without compliance over a period of two calendar years constitutes an increase to a Level 3 violation. License: Suspended immediately for remainder of the license year or 60 calendar days, whichever is longer. Certificate: Suspended immediately for remainder of the license year or 60 calendar days, whichever is longer. Certificate: If the individual is not part of the violation but will be affected by the loss of the employer's contractor license, the certificate will be changed to INACTIVE status until the contractor obtains a valid license or the certificate holder has a new employer.
3	\$5,000 per violation	Evidence of two or more violations without compliance over a period of three calendar years constitutes an increase to a Level 3 violation. License: Suspended immediately for remainder of the license year or 180 calendar days, whichever is longer. Certificate: Suspended immediately for remainder of the license year or 180 calendar days, whichever is longer. Certificate: If the individual is not part of the violation but will be affected by the loss of the employer's contractor license, the certificate will be changed to INACTIVE status until the contractor obtains a valid license or the certificate holder has a new employer.

(3) Civil penalties shall be resolved through the following:

(a) **Pay the penalty** by returning the notice and payment to the director at State Fire Marshal's Office, P.O. Box 42642, Olympia, WA 98504-2642 within 30 days from the date the penalty was issued. Payments must be made by check or money order payable to the Washington state patrol.

(b) **Request an informal conference** as outlined in WAC 212-90-235.

(c) **Request a formal hearing** as outlined in WAC 212-90-205 or 212-90-240.

[]

NEW SECTION

WAC 212-90-235 Informal conference. (1) The director will provide an opportunity for any person to informally discuss a civil penalty that has been assessed against them.

(2) An informal conference may be requested prior to a request for a formal hearing. However, it will not exceed nor extend the 30-

day timeline allotted for the request of a formal hearing - Regardless of the outcome.

- (3) The request for an informal hearing may be in any form and:
 - (a) Must be addressed to the mitigation officer;
 - (b) Be received by the director no more than 30 days from the issue date of the civil penalty; and
 - (c) Clearly state the subject to be discussed.
- (4) Depending on the availability and time constraints of the person making the request and the hearings officer, the informal conference may be a personal meeting or conference call depending on the availability of the parties and the available technology.
- (5) The director may, for good cause, choose to amend, withdraw, or reduce the civil penalty as a result of an informal conference.

[]

NEW SECTION

WAC 212-90-240 Formal hearing. (1) Any person may request a formal hearing to appeal a civil penalty issued under this chapter at any time before or after the request of an informal conference, as long as the 30 day period from the date of issue listed on the citation has not elapsed. If requesting a formal hearing by mail, the request must be post marked by midnight on the day the request is due.

(2) The director will arrange for a hearings officer to conduct the formal hearing and will notify by letter the person requesting the hearing (or their designated representative) of the date, time, location, and hearings officer conducting the formal hearing.

(3) The hearings officer will hear the case and, within 90 days of the hearing, render a proposed opinion and order including recommended findings of fact and conclusions of law, according to chapters 34.05 RCW and 10-08 WAC.

(4) The formal hearing will be conducted as follows:

- (a) The hearings officer will act as an impartial third party.
- (b) It is not necessary for the person who requested the hearing to be represented by legal counsel.
- (c) An official record will be made through a scribe.
- (d) Testimony will be taken under oath.
- (e) All evidence of a type commonly relied upon by a reasonably prudent person in the conduct of their serious affairs is admissible.
- (f) Hearsay evidence is admissible if it meets the statutory standards for being reliable and trustworthy.
- (g) A proposed opinion and order will be provided.

(5) The proposed opinion and order shall be reviewed by the director and, if accepted, be finalized and issued as a final order.

[]

NEW SECTION

WAC 212-90-245 Penalty adjustments. (1) The assessment of adjustment of penalties for amounts other than those set by chapter

18.270 RCW will be done only by the director through a hearings process either formally or informally.

(2) The assessment of penalties for not being in conformance with chapter 18.270 RCW, or this chapter may be made only after considering:

- (a) The gravity and magnitude of the violation.
- (b) The person's previous record.
- (c) Such other considerations as the director may consider appropriate.
- (d) The uniformity and consistency in the application of violations or penalties statewide.

[]

NEW SECTION

WAC 212-90-250 Payment of civil penalty. (1) The penalty must be paid to the director within 30 days after an order assessing a civil penalty becomes final by operation of law or on an appeal.

(2) A request can be made through an informal or formal conference to make installment payments on a civil penalty. If the mitigation officer authorizes installment payments during an informal or formal hearing, the payment plan will be developed and agreed upon at the hearing. Failure to comply with the payment plan will void the payment plan and the remaining balance must be paid by the next business day.

(3) If the licensed contractor or certificate holder fails to pay the full penalty or comply with the payment plan as provided by subsection (2) of this section:

(a) The license or certificate of competency will be revoked for the remainder of the current license or certificate year and will not be reinstated or renewed until the penalty is paid in full.

(b) The attorney general may bring an action in the name of the director in the superior court of Thurston County or of any county in which the violator may do business to collect any penalty imposed under chapter 18.270 RCW.

[]

WSR 22-22-073
PERMANENT RULES
UTILITIES AND TRANSPORTATION
COMMISSION

[Docket U-220271, General Order R-605—Filed October 31, 2022, 10:34 a.m., effective December 1, 2022]

In the matter of amending WAC 480-90-252, 480-100-252, 480-110-505, 480-120-382, and 480-120-385, relating to commission regulatory fees.

1 STATUTORY OR OTHER AUTHORITY: The Washington utilities and transportation commission (commission) takes this action under Notice No. WSR 22-17-113, filed with the code reviser on August 22, 2022. The commission has authority to take this action pursuant to RCW 80.01.040, 80.04.160, 81.01.010, and 84.24.010.

2 STATEMENT OF COMPLIANCE: This proceeding complies with the Administrative Procedure Act (chapter 34.05 RCW), the State Register Act (chapter 34.08 RCW), the State Environmental Policy Act of 1971 (chapter 43.21C RCW), and the Regulatory Fairness Act (chapter 19.85 RCW).

3 DATE OF ADOPTION: The commission adopts these rules on the date this order is entered.

4 CONCISE STATEMENT OF PURPOSE AND EFFECT OF THE RULE: RCW 34.05.325(6) requires the commission to prepare and publish a concise explanatory statement about adopted rules. The statement must identify the commission's reasons for adopting the rules, describe the differences between the version of the proposed rules published in the register and the rules adopted (other than editing changes), summarize the comments received regarding the proposed rule changes, and state the commission's responses to the comments reflecting the commission's consideration of them.

5 To avoid unnecessary duplication in the record of this docket, the commission designates the discussion in this order as its concise explanatory statement. This order provides a complete but concise explanation of the agency's actions and its reasons for taking those actions.

6 REFERENCE TO AFFECTED RULES: This order amends WAC 480-90-252 Federal Energy Regulatory Commission (FERC) Form No. 2, 480-100-252 Federal Energy Regulatory Commission (FERC) Form No. 1, 480-110-505 Accounting and reporting requirements and regulatory fees, 480-120-382 Annual report for competitively classified telecommunications companies, and 480-120-385 Annual report for telecommunications companies not classified as competitive.

7 PREPROPOSAL STATEMENT OF INQUIRY AND ACTIONS THEREUNDER: The commission filed a preproposal statement of inquiry (CR-101) on July 1, 2022, at WSR 22-14-081. The statement advised interested persons that the commission was considering entering a rule making to implement amendments to RCW 80.24.010 updating the commission's authority to assess regulatory fees. The commission also informed persons of this inquiry by providing notice of the subject and the CR-101 to everyone on the commission's list of persons requesting such information pursuant to RCW 34.05.320(3) and by sending notice to the commission's list of regulated utility companies whose rates could be increased. Pursuant to the notice, the commission invited interested persons to provide written comments to the commission on the contemplated amendments.

8 NOTICE OF PROPOSED RULE MAKING: The commission filed a notice of proposed rule making (CR-102) on August 22, 2022, at WSR 22-17-113. The commission scheduled this matter for oral comment and adoption under Notice No. WSR 22-17-113 at 9:30 a.m. on October 17, 2022, via Zoom. The no-

tice provided interested persons the opportunity to submit further written comments to the commission.

9 WRITTEN COMMENTS: The commission received written comments from the Washington Independent Telecommunications Association (WITA) in response to both the CR-101 and CR-102. In its comments, WITA states that it does not object to the proposed amendments but does object to any future actual increase to the regulatory fees paid by WITA's members. The proposed amendments to the rules only incorporate the legislature's amendment of the statute. The statute and the proposed amended rules all continue to authorize the commission to adjust the regulatory fees that utilities pay, and the commission will address any adjustments to those fees, including WITA's request to maintain the current fee levels for its members, in a separate docket.

10 SMALL BUSINESS ECONOMIC IMPACT STATEMENT: The only substantive change in the proposed revisions to the rules is to incorporate the legislature's amendment of the statute. Accordingly, no small business economic impact statement is required. The commission nevertheless undertook an analysis of the proposed rules' economic impact on small businesses. The commission served a questionnaire on affected companies requesting information on this issue but received no responses. Regulated companies may include their regulatory fees in the rates they charge their customers, and the commission has no indication that any rate increases to recover the proposed increase in fees would have a significant impact on any small business. The proposed rules, therefore, will not have a significant economic impact on small businesses.

11 RULE-MAKING HEARING: The commission considered the proposed rules for adoption at a rule-making hearing on Monday, October 17, 2022, before Chair David W. Danner, Commissioner Ann E. Rendahl, and Commissioner Milton H. Doumit. The commission heard a presentation from commission staff, but no other person made oral comments.

12 SUGGESTIONS FOR CHANGE THAT ARE REJECTED/ACCEPTED: There were no suggested changes to the proposed rules.

13 COMMISSION ACTION: After considering all the information regarding this proposal, the commission finds and concludes that it should amend the rules as proposed in the CR-102 at WSR 22-17-113.

14 STATEMENT OF ACTION; STATEMENT OF EFFECTIVE DATE: After reviewing the entire record, the commission determines that WAC 480-90-252, 480-100-252, 480-110-505, 480-120-382, and 480-120-385, should be amended to read as set forth in Appendix A as rules of the Washington utilities and transportation commission, to take effect pursuant to RCW 34.05.380(2) 31 days after filing with the code reviser.

Number of Sections Adopted in Order to Comply with Federal Statute: New 0, Amended 0, Repealed 0; Federal Rules or Standards: New 0, Amended 0, Repealed 0; or Recently Enacted State Statutes: New 0, Amended 5, Repealed 0.

Number of Sections Adopted at the Request of a Nongovernmental Entity: New 0, Amended 0, Repealed 0.

Number of Sections Adopted on the Agency's own Initiative: New 0, Amended 0, Repealed 0.

Number of Sections Adopted in Order to Clarify, Streamline, or Reform Agency Procedures: New 0, Amended 0, Repealed 0.

Number of Sections Adopted using Negotiated Rule Making: New 0, Amended 0, Repealed 0; Pilot Rule Making: New 0, Amended 0, Repealed 0; or Other Alternative Rule Making: New 0, Amended 5, Repealed 0.

ORDER

THE COMMISSION ORDERS:

15 The commission amends WAC 480-90-252, 480-100-252, 480-110-505, 480-120-382, and 480-120-385, to read as set forth in Appendix A, as rules of the Washington utilities and transportation commission, to take effect 31 days after the date of filing with the code reviser pursuant to RCW 34.05.380(2).

16 This order and the rule set out below, after being recorded in the register of the Washington utilities and transportation commission, shall be forwarded to the code reviser for filing pursuant to chapters 80.01 and 34.05 RCW and chapter 1-21 WAC.

DATED at Lacey, Washington, October 28, 2022.

Washington Utilities and Transportation Commission
David W. Danner, Chair
Ann E. Rendahl, Commissioner
Milton H. Doumit, Commissioner

Appendix A
[REVISED - RULES]

Reviser's note: The brackets and enclosed material in the text of the above section occurred in the copy filed by the agency and appear in the Register pursuant to the requirements of RCW 34.08.040.

OTS-4016.1

AMENDATORY SECTION (Amending WSR 06-08-057, filed 3/31/06, effective 5/1/06)

WAC 480-90-252 Federal Energy Regulatory Commission (FERC) Form No. 2. (1) Each gas utility must use the annual report form (FERC Form No. 2) promulgated by the Federal Energy Regulatory Commission in Title 18 of the Code of Federal Regulations, Part 260, for purposes of this report to the commission. Data required by RCW 80.04.080 (Annual reports), but not included in the FERC Form No. 2, must also be submitted with the annual report. The utility must submit the annual report for the preceding calendar year, along with the regulatory fee, by May 1st of each year. If not presented in the prescribed FERC Form No. 2, the annual report must include the following data per customer class for the calendar year: Revenues, average customer count, and total unit sales. Information about the FERC Form No. 2 regarding the version adopted and where to obtain it is set out in WAC 480-90-999 (Adoption by reference).

(2) Each utility must also submit to this commission, in essentially the same format and content as the FERC Form No. 2, a report that documents the costs incurred and the property necessary to furnish utility service to its customers and the revenues obtained in the state of Washington. The report must include the following data per customer class for the calendar year: Revenues, average customer count, and total unit sales.

(3) Combination and multistate utilities must submit with the annual report their cost allocation methods necessary to develop results of operations for the state of Washington. Approval of cost allocation methods for rate-making purposes is accomplished only by commission order.

(4) The total utility results of operations reported by each utility in its annual report to the commission must agree with the results of operations shown on the utility's books and records.

(5) **Regulatory fees.** The gas utility annual regulatory fee is set by statute at one-tenth of one percent of the first (~~(fifty thousand dollars)~~) \$50,000 of gross intrastate operating revenue plus (~~(two-tenths)~~) four-tenths of one percent of any gross intrastate operating revenue in excess of (~~(fifty thousand dollars)~~) \$50,000.

(a) The maximum regulatory fee is assessed each year, unless the commission issues an order establishing the regulatory fee at an amount less than the statutory maximum.

(b) The minimum regulatory fee that a gas utility must pay is (~~(twenty dollars)~~) \$20.

(c) The (~~(twenty dollar)~~) \$20 minimum regulatory fee is waived for any gas utility with less than (~~(twenty thousand dollars)~~) \$20,000 in gross intrastate operating revenue.

(d) The commission does not grant extensions for payment of regulatory fees.

(e) If a company does not pay its regulatory fee by May 1st, the commission will assess an automatic late fee of two percent of the amount due, plus one percent interest for each month the fee remains unpaid.

[Statutory Authority: 80.01.040(4), 81.04.160, and 34.05.353. WSR 06-08-057 (Docket A-060085, General Order No. R-531), § 480-90-252, filed 3/31/06, effective 5/1/06. Statutory Authority: RCW 80.01.040, 80.04.160, 81.04.160 and 34.05.353. WSR 05-21-022 (Docket No. A-050271, General Order No. R-521), § 480-90-252, filed 10/10/05, effective 11/10/05; WSR 05-06-051 (Docket No. A-021178 and TO-030288, General Order No. R-518), § 480-90-252, filed 2/28/05, effective 3/31/05.]

OTS-4017.1

AMENDATORY SECTION (Amending WSR 06-08-057, filed 3/31/06, effective 5/1/06)

WAC 480-100-252 Federal Energy Regulatory Commission (FERC) Form

No. 1. (1) Each electric utility must use the annual report form (FERC Form No. 1) promulgated by the Federal Energy Regulatory Commission in Title 18 of the Code of Federal Regulations, Part 141, for purposes of this report to the commission. Data required by RCW 80.04.080 (Annual reports), but not included in the FERC Form No. 1, must also be submitted with the annual report. The utility must submit the annual report for the preceding calendar year, along with the regulatory fee, by May 1st of each year. If not presented in the prescribed FERC Form No. 1, the annual report must include the following data per customer class for the calendar year: Revenues, average customer count, and total unit sales. Information about the FERC Form No. 1 regarding the version adopted and where to obtain it is set out in WAC 480-100-999 (Adoption by reference).

(2) Each utility must also submit to this commission, in essentially the same format and content as the FERC Form No. 1, a report

that documents the costs incurred and the property necessary to furnish utility service to its customers and the revenues obtained in the state of Washington. The report must include the following data per customer class for the calendar year: Revenues, average customer count, and total unit sales.

(3) Combination and multistate utilities must submit with the annual report their cost allocation methods necessary to develop results of operations for the state of Washington. Approval of cost allocation methods for rate-making purposes is accomplished only by commission order.

(4) The total utility results of operations reported by each utility in its annual report to the commission must agree with the results of operations shown on the utility's books and records.

(5) **Regulatory fees.** The electric utility annual regulatory fee is set by statute at one-tenth of one percent of the first (~~fifty thousand dollars~~) \$50,000 of gross intrastate operating revenue plus (~~two-tenths~~) four-tenths of one percent of any gross intrastate operating revenue in excess of (~~fifty thousand dollars~~) \$50,000.

(a) The maximum regulatory fee is assessed each year, unless the commission issues an order establishing the regulatory fee at an amount less than the statutory maximum.

(b) The minimum regulatory fee that an electric utility must pay is (~~twenty dollars~~) \$20.

(c) The (~~twenty dollar~~) \$20 minimum regulatory fee is waived for any electric utility with less than (~~twenty thousand dollars~~) \$20,000 in gross intrastate operating revenue.

(d) The commission does not grant extensions for payment of regulatory fees.

(e) If a company does not pay its regulatory fee by May 1st, the commission will assess an automatic late fee of two percent of the amount due, plus one percent interest for each month the fee remains unpaid.

[Statutory Authority: RCW 80.01.040(4), 81.04.160, and 34.05.353. WSR 06-08-057 (Docket A-060085, General Order No. R-531), § 480-100-252, filed 3/31/06, effective 5/1/06. Statutory Authority: RCW 80.01.040, 80.04.160, 81.04.160 and 34.05.353. WSR 05-06-051 (Docket No. A-021178 and TO-030288, General Order No. R-518), § 480-100-252, filed 2/28/05, effective 3/31/05.]

OTS-4018.1

AMENDATORY SECTION (Amending WSR 06-08-057, filed 3/31/06, effective 5/1/06)

WAC 480-110-505 Accounting and reporting requirements and regulatory fees. (1) Water companies must use the uniform system of accounts (USOA) published by the National Association of Regulatory Utility Commissioners (NARUC). Information about the USOA regarding the version adopted and where to obtain it is set out in WAC 480-110-999 (Adoption by reference). The USOA sets out the accounting requirements for Class A, B, and C water companies.

Water companies are classified by revenues.

Class	Annual Gross Operating Revenue
A	\$1,000,000 or more
B	\$200,000 to \$999,999
C	Less than \$200,000

(2) A water company may use the accounting requirements for a higher class if it chooses.

(3) The commission will distribute an annual report form that each water company must complete and file with the commission for the prior calendar year. The annual report must be filed, and the company's regulatory fee paid, no later than May 1st of each year.

(4) A written request for the extension of the time for filing the annual report can be made prior to May 1st. The commission does not grant an extension of time for payment of regulatory fees.

(5) The maximum water company regulatory fee is set by statute at one-tenth of one percent of the first (~~(fifty thousand dollars)~~) \$50,000 of gross intrastate operating revenue plus (~~(two-tenths)~~) four-tenths of one percent of any gross operating revenue in excess of (~~(fifty thousand dollars)~~) \$50,000.

(a) The maximum regulatory fee is assessed each year, unless the commission issues an order establishing the regulatory fee at an amount less than the statutory maximum.

(b) The minimum regulatory fee that a water company must pay is (~~(twenty dollars)~~) \$20.

(c) The (~~(twenty-dollar)~~) \$20 minimum regulatory fee is waived for any water company with less than (~~(twenty thousand dollars)~~) \$20,000 in gross intrastate operating revenue.

(d) The commission does not grant extensions for payment of regulatory fees.

(e) If a company does not pay its regulatory fee by May 1st, the commission will assess an automatic late fee of two percent of the amount due, plus one percent interest for each month the fee remains unpaid.

[Statutory Authority: RCW 80.01.040(4), 81.04.160, 34.05.353. WSR 06-08-057 (Docket A-060085, General Order No. R-531), § 480-110-505, filed 3/31/06, effective 5/1/06. Statutory Authority: RCW 80.01.040, 80.04.160, 81.04.160 and 34.05.353. WSR 05-06-051 (Docket No. A-021178 and TO-030288, General Order No. R-518), § 480-110-505, filed 2/28/05, effective 3/31/05.]

OTS-4019.1

AMENDATORY SECTION (Amending WSR 15-08-043, filed 3/26/15, effective 4/26/15)

WAC 480-120-382 Annual report for competitively classified telecommunications companies. The commission will distribute an annual report form including a regulatory fee form. A competitively classified company must:

(1) Complete both forms, file them with the commission, and pay its regulatory fee, no later than May 1st of each year;

- (2) Provide total number of access lines as required on the annual report form;
- (3) Provide income statement and balance sheet for total company;
- (4) Provide revenues for Washington and Washington intrastate operations subject to commission jurisdiction;
- (5) Keep accounts using generally accepted accounting principles (GAAP), or any other accounting method acceptable to the commission. In addition, the accounts must allow for the identification of revenues supporting subsection (4) of this section; and
- (6) **Regulatory fees.** The telecommunications annual regulatory fee is set by statute at one-tenth of one percent of the first (~~fifty thousand dollars~~) \$50,000 of gross intrastate operating revenue plus (~~two-tenths~~) four-tenths of one percent of any gross intrastate operating revenue in excess of (~~fifty thousand dollars~~) \$50,000.
- (a) The maximum regulatory fee is assessed each year, unless the commission issues an order establishing the regulatory fee at an amount less than the statutory maximum.
- (b) The minimum regulatory fee that a company must pay is (~~one hundred fifty dollars~~) \$150.
- (c) The commission does not grant extensions for payment of regulatory fees.
- (d) If a company does not pay its regulatory fee by May 1st, the commission will assess an automatic late fee of two percent of the amount due, plus one percent interest for each month the fee remains unpaid.
- (e) The commission may take action to revoke a company's registration certificate if it fails to pay its regulatory fee.

[Statutory Authority: Chapter 19.122 RCW, RCW 19.122.053, 80.01.040, and 80.04.160. WSR 15-08-043 (Docket UT-140680, General Order R-580), § 480-120-382, filed 3/26/15, effective 4/26/15. Statutory Authority: RCW 80.01.040(4), 81.04.160, and 34.05.353. WSR 06-08-057 (Docket A-060085, General Order No. R-531), § 480-120-382, filed 3/31/06, effective 5/1/06. Statutory Authority: RCW 80.01.040, 80.04.160, 81.04.160 and 34.05.353. WSR 05-06-051 (Docket No. A-021178 and TO-030288, General Order No. R-518), § 480-120-382, filed 2/28/05, effective 3/31/05.]

AMENDATORY SECTION (Amending WSR 15-08-043, filed 3/26/15, effective 4/26/15)

WAC 480-120-385 Annual report for telecommunications companies not classified as competitive. (1) Annual reports for companies not classified as competitive. The commission will distribute an annual report form, a regulatory fee form, and financial information templates. A telecommunications company not classified as competitive must:

- (a) Return the annual report and regulatory fee forms and pay its regulatory fee, no later than May 1st of each year;
- (b) Provide total number of access lines (as required on the annual report form referred to in (a) of this subsection); and
- (c) Complete the financial information templates. The financial information templates include income statement, balance sheet, and rate base items. The templates also include sections on total company and results of operations for Washington and Washington intrastate.

The commission will provide the templates each year and the company must return the completed templates as follows:

- (i) Class A companies must file the required financial information templates no later than May 1st each year.
- (ii) Class B companies must file the required financial information templates no later than July 1st of each year.
- (iii) Class B companies are not exempt from these filing requirements.

(2) Methods used to determine Washington intrastate results of operations must be acceptable to the commission.

(3) This rule does not supersede any reporting requirements specified in a commission rule or order, or limit the commission's authority to request additional information.

(4) **Regulatory fees.** The telecommunications annual regulatory fee is set by statute at one-tenth of one percent of the first (~~fifty thousand dollars~~) \$50,000 of gross intrastate operating revenue plus (~~two-tenths~~) four-tenths of one percent of any gross intrastate operating revenue in excess of (~~fifty thousand dollars~~) \$50,000.

(a) The maximum regulatory fee is assessed each year, unless the commission issues an order establishing the regulatory fee at an amount less than the statutory maximum.

(b) The minimum regulatory fee that a company must pay is (~~one hundred fifty dollars~~) \$150.

(c) The commission does not grant extensions for payment of regulatory fees.

(d) If a company does not pay its regulatory fee by May 1st, the commission will assess an automatic late fee of two percent of the amount due, plus one percent interest for each month the fee remains unpaid.

[Statutory Authority: Chapter 19.122 RCW, RCW 19.122.053, 80.01.040, and 80.04.160. WSR 15-08-043 (Docket UT-140680, General Order R-580), § 480-120-385, filed 3/26/15, effective 4/26/15. Statutory Authority: RCW 80.01.040(4), 81.04.160, and 34.05.353. WSR 06-08-057 (Docket A-060085, General Order No. R-531), § 480-120-385, filed 3/31/06, effective 5/1/06. Statutory Authority: RCW 80.01.040, 80.04.160, 81.04.160 and 34.05.353. WSR 05-06-051 (Docket No. A-021178 and TO-030288, General Order No. R-518), § 480-120-385, filed 2/28/05, effective 3/31/05.]

WSR 22-22-074
PERMANENT RULES
COUNTY ROAD

ADMINISTRATION BOARD

[Filed October 31, 2022, 12:16 p.m., effective December 1, 2022]

Effective Date of Rule: Thirty-one days after filing.

Purpose: Amending chapter 136-400 WAC to make changes to the County Ferry Capital Improvement Program.

Citation of Rules Affected by this Order: Amending WAC 136-400-020, 136-400-030, and 136-400-080.

Statutory Authority for Adoption: RCW 36.78.07[0].

Other Authority: RCW 47.56.725(4).

Adopted under notice filed as WSR 22-19-026 on September 13, 2022.

Number of Sections Adopted in Order to Comply with Federal Statute: New 0, Amended 0, Repealed 0; Federal Rules or Standards: New 0, Amended 0, Repealed 0; or Recently Enacted State Statutes: New 0, Amended 0, Repealed 0.

Number of Sections Adopted at the Request of a Nongovernmental Entity: New 0, Amended 0, Repealed 0.

Number of Sections Adopted on the Agency's own Initiative: New 0, Amended 3, Repealed 0.

Number of Sections Adopted in Order to Clarify, Streamline, or Reform Agency Procedures: New 0, Amended 0, Repealed 0.

Number of Sections Adopted using Negotiated Rule Making: New 0, Amended 0, Repealed 0; Pilot Rule Making: New 0, Amended 0, Repealed 0; or Other Alternative Rule Making: New 0, Amended 0, Repealed 0.

Date Adopted: October 27, 2022.

Jane Wall
Executive Director

OTS-4092.1

AMENDATORY SECTION (Amending WSR 08-10-026, filed 4/28/08, effective 5/29/08)

WAC 136-400-020 County and project eligibility. (1) Counties eligible to apply for county ferry capital improvement funds are Pierce, Skagit, Wahkiakum, and Whatcom.

(2) For the project to be eligible it must be included in both the county's six-year transportation program and its ferry system (~~(fourteen-year)~~) 14-year long range capital improvement plan as described in WAC 136-400-040.

(3) Any county holding an approved and executed county ferry capital improvement program contract is ineligible to submit a project funding application for additional ferry capital improvement funds until the existing contract is fully performed or has been mutually terminated.

(4) Once a county has received funding for vessel replacement under this program, the county is no longer eligible for future replacement of that vessel as referenced in WAC 136-400-030(1). A county will

remain eligible for project types referenced in WAC 136-400-030 (2), (3), (4) and (5).

[Statutory Authority: Chapter 36.79 RCW. WSR 08-10-026, § 136-400-020, filed 4/28/08, effective 5/29/08. Statutory Authority: 1991 c 310 § 1(4). WSR 91-21-138 (Order 85), § 136-400-020, filed 10/23/91, effective 11/23/91.]

AMENDATORY SECTION (Amending WSR 08-10-026, filed 4/28/08, effective 5/29/08)

WAC 136-400-030 Definition of ferry capital improvement projects. County ferry capital improvement projects shall include the following:

- (1) Purchase of a new vessel((s)) which replaces an existing vessel;
- (2) Major vessel refurbishment (e.g., engines, structural steel, controls) that substantially extends the life of the vessel;
- (3) Facility refurbishment/replacement (e.g., complete replacement, major rebuilding or redecking of a dock) that substantially extends the life of the facility;
- (4) Installation of items that substantially improve ferry facilities or operations; and/or
- (5) Construction of infrastructure that provides new or additional access or increases the capacity of terminal facilities.

[Statutory Authority: Chapter 36.79 RCW. WSR 08-10-026, § 136-400-030, filed 4/28/08, effective 5/29/08. Statutory Authority: 1991 c 310 § 1(4). WSR 91-21-138 (Order 85), § 136-400-030, filed 10/23/91, effective 11/23/91.]

AMENDATORY SECTION (Amending WSR 08-10-026, filed 4/28/08, effective 5/29/08)

WAC 136-400-080 Funding by the legislature. County ferry capital improvement project requests approved by the county road administration board shall be submitted to the legislature for funding out of amounts available under RCW 46.68.090 (2)(h) as part of the biennial or supplemental budget request of the county road administration board.

The county road administration board shall, within (~~ten~~) 10 days of the signing of the transportation budget, notify each county having an approved project of such approval and of the amount of county ferry capital improvement funding (~~allocated~~) appropriated to each approved project. The county road administration board shall offer each county a contract for each approved project setting forth the terms and conditions under which funds will be provided.

[Statutory Authority: Chapter 36.79 RCW. WSR 08-10-026, § 136-400-080, filed 4/28/08, effective 5/29/08; WSR 99-01-021, § 136-400-080, filed 12/7/98, effective 1/7/99. Statutory Authority: 1991 c 310 § 1(4). WSR 91-21-138 (Order 85), § 136-400-080, filed 10/23/91, effective 11/23/91.]

WSR 22-22-075

PERMANENT RULES

DEPARTMENT OF LICENSING

[Filed October 31, 2022, 1:16 p.m., effective December 1, 2022]

Effective Date of Rule: Thirty-one days after filing.

Purpose: The department of licensing is amending rules to allow driver training schools to offer driver training education classes virtually after the state of emergency ends in Washington state.

Citation of Rules Affected by this Order: Repealing WAC 308-108-190 Emergency clause; and amending WAC 308-108-020 Definitions, 308-108-120 Administration, 308-108-130 Inspection and review, 308-108-150 Course requirements, 308-108-165 Prohibition on wireless communication devices during instruction, and 308-108-170 Ensuring student accomplishment.

Statutory Authority for Adoption: RCW 46.82.290 Administration of chapter—Adoption of rules, and 46.01.110 Rule-making authority.

Adopted under notice filed as WSR 22-19-098 on September 21, 2022.

Changes Other than Editing from Proposed to Adopted Version: Insert "of" after "the duration" in WAC 308-108-150 Course requirements, subsection (4), for grammatical accuracy. It now reads "... where the instructor is present for the duration of instruction ..."

Number of Sections Adopted in Order to Comply with Federal Statute: New 0, Amended 0, Repealed 0; Federal Rules or Standards: New 0, Amended 0, Repealed 0; or Recently Enacted State Statutes: New 0, Amended 0, Repealed 0.

Number of Sections Adopted at the Request of a Nongovernmental Entity: New 0, Amended 0, Repealed 0.

Number of Sections Adopted on the Agency's own Initiative: New 0, Amended 0, Repealed 0.

Number of Sections Adopted in Order to Clarify, Streamline, or Reform Agency Procedures: New 0, Amended 0, Repealed 0.

Number of Sections Adopted using Negotiated Rule Making: New 0, Amended 6, Repealed 1; Pilot Rule Making: New 0, Amended 0, Repealed 0; or Other Alternative Rule Making: New 0, Amended 0, Repealed 0.

Date Adopted: October 31, 2022.

Ellis Starrett
Rules and Policy Manager

OTS-4098.2

AMENDATORY SECTION (Amending WSR 09-21-093, filed 10/20/09, effective 11/20/09)

WAC 308-108-020 Definitions. The definitions of this section apply throughout this chapter unless the context clearly requires otherwise:

(1) "Behind the wheel instruction" means that portion of a traffic safety education course that consists of on-street, dual-controlled vehicle operation or similar instruction given under simulated conditions that has been approved by the director.

(2) "Branch office" or "branch classroom" means a facility within a (~~(thirty-five mile)~~) 35-mile radius of a driver training school's established place of business, except where the (~~(thirty-five mile)~~) 35-mile radius requirement has been waived or extended by the department as provided by RCW 46.82.360 (6) (c), that has been approved by the department for use by the driver training school.

(3) "Classroom," defined in RCW 46.82.280(2), may also include a virtual classroom environment when video conferencing technology is capable of two-way communication between the instructor and all students.

(4) "Engage in a course of instruction" means to enroll in, schedule, collect a fee for, or sign an application for an instruction permit in order to attend or take part in a driver training education course.

(~~((4))~~) (5) "Inactive instructor" means an instructor with a valid Washington instructor's license who is no longer employed by or otherwise associated with a licensed driver training school.

(~~((5))~~) (6) "Instructor-led" means person-to-person learning where students can ask questions, receive feedback in real-time, and interaction and discussion are enabled.

(7) "Instructor-trainer" means a currently licensed instructor who is training traffic safety education instructors and who has not less than:

(a) One thousand hours of experience in providing traffic safety education in the past year;

(b) Five years of previous experience in providing traffic safety education; or

(c) One thousand hours or five years experience in the field of traffic safety and proof of training acceptable to the director in how to teach and train others, and not less than (~~(three hundred)~~) 300 hours of previous experience in training others.

(~~((6))~~) (8) "Records" means all documents, papers and reports required to own a driver training school, including but not limited to:

(a) Vehicle registration, title, insurance policy, and maintenance information;

(b) Business financial documents, such as franchise agreements, corporate documents, bank records, partnership agreements, lease agreements, and purchase and sale agreements; and

(c) Student classroom and behind-the-wheel instruction reports.

(~~((7))~~) (9) "Student" means any person enrolled in an approved driver training education course who is at least (~~(fifteen)~~) 15 years of age.

[Statutory Authority: RCW 46.82.290. WSR 09-21-093, § 308-108-020, filed 10/20/09, effective 11/20/09. Statutory Authority: RCW 46.82.290, 46.82.310, 46.82.320, 46.82.330, and 46.82.340. WSR 07-01-069, § 308-108-020, filed 12/18/06, effective 1/18/07. Statutory Authority: RCW 46.82.290. WSR 05-16-061, § 308-108-020, filed 7/29/05, effective 8/29/05.]

AMENDATORY SECTION (Amending WSR 09-21-093, filed 10/20/09, effective 11/20/09)

WAC 308-108-120 Administration. (1) The driver training school's license and all instructor certificates shall be posted in a

conspicuous place ((at the location where instruction takes place. The school license must be posted)) before engaging students in a course of instruction. An additional electronic copy will be provided to school customers, upon request.

(2) Each driver training school shall adopt and provide for its customers a written policy that includes, but is not limited to:

- (a) Enrollment criteria;
- (b) Student fees and student fee refunds;
- (c) Course failures and course repeats;
- (d) The minimum and maximum course duration;
- (e) Refusing to allow a student to attend a driver training education course before the age of (~~fifteen~~) 15 years;
- (f) Refusing to enroll new students in a driver education course after the first three classes have been completed; and
- (g) Information about Washington's intermediate licensing requirements, restrictions, and penalties and a place for parents to initial indicating that they have received the information.

(3) Driver training school owners and instructors shall maintain individual student records on forms provided by the department or on substantially similar forms that have been approved by the department. Student records shall document for each student:

- (a) Course attendance, starting, and ending dates;
- (b) The dates and times for each session of classroom and behind the wheel instruction;
- (c) Classroom and behind the wheel progress and time involvement or flowchart;
- (d) Classroom and behind the wheel performance evaluation results;
- (e) The name and signature of the instructor who provided each session of classroom and behind the wheel instruction; and
- (f) That both the student and parent received intermediate license requirements, restriction, and penalty information.

(4) Student records must be maintained by a driver training school for three years from the date instruction has ended.

(5) Driver training school records that must be maintained by a driver training school for three years, include but are not limited to:

- (a) The school's written curriculum guide;
- (b) Insurance policies;
- (c) Collision or injury reports;
- (d) Traffic safety education vehicle registration records; and
- (e) Records of any traffic violations committed by an instructor employed by the school.

(6) Upon the sale or other transfer of a school by its owner, the school and student records shall be transferred to the new owner and become the property and responsibility of the new owner.

(7) The driving school owner must notify the department within (~~thirty~~) 30 days of closing the school and submit all unused traffic safety certificates and student course completion reports to the department.

(8) Class size must not exceed city fire code requirements for the classroom.

(9) Traffic safety education classroom hours shall not overlap between two or more classes.

(10) Failure to renew a school license before it expires will put all related branch office or branch classroom licenses into an inactive status.

(11) Student records are subject to department audit and inspection anytime after ~~((ninety))~~ 90 days of the school's initial licensing, or as soon as practicable for the department.

(12) Branch office or classroom locations must display an official license issued by the department in a conspicuous place.

[Statutory Authority: RCW 46.82.290, WSR 09-21-093, § 308-108-120, filed 10/20/09, effective 11/20/09. Statutory Authority: RCW 46.82.290, 46.82.310, 46.82.320, 46.82.330, and 46.82.340. WSR 07-01-069, § 308-108-120, filed 12/18/06, effective 1/18/07. Statutory Authority: RCW 46.82.290. WSR 05-16-061, § 308-108-120, filed 7/29/05, effective 8/29/05.]

AMENDATORY SECTION (Amending WSR 07-01-069, filed 12/18/06, effective 1/18/07)

WAC 308-108-130 Inspection and review. (1) The department may require that a driver training school owner submit to an inspection or review of the school's operations and records at any time during regular business hours.

(2) Records shall be housed electronically or via hard copy and ~~((immediately available for inspection at a driver training school's primary place of business. Branch office records may be housed at the primary place of business, however, such records must be))~~ made available for inspection ~~((at the branch location))~~ within ~~((twenty-four hours))~~ two business days following a request for review by the department.

(3) Schools will provide the department access to virtual classroom sessions upon request.

[Statutory Authority: RCW 46.82.290, 46.82.310, 46.82.320, 46.82.330, and 46.82.340. WSR 07-01-069, § 308-108-130, filed 12/18/06, effective 1/18/07. Statutory Authority: RCW 46.82.290. WSR 05-16-061, § 308-108-130, filed 7/29/05, effective 8/29/05.]

AMENDATORY SECTION (Amending WSR 19-07-058, filed 3/18/19, effective 4/18/19)

WAC 308-108-150 Course requirements. Driver training schools that provide education for persons under the age of ~~((eighteen))~~ 18 must ensure their course:

(1) Includes a minimum of ~~((thirty))~~ 30 hours of classroom instruction;

(2) Meets the behind the wheel instruction and observation requirements of WAC 308-108-160;

(3) Has a minimum of one hour and no more than two hours of classroom instruction and no more than one hour of behind the wheel instruction during a single day, except when adding a make-up class, in which case classroom instruction must not exceed four hours in a single day;

(4) Has a classroom portion that is ~~((at least fifty percent))~~ instructor-led ~~((with verbal))~~, where the instructor is present for the duration of instruction ((consisting)), and consists of:

- (a) ~~((In-person training;))~~ Lecture, group work, videos, and/or other activities;
- (b) Teacher and student interaction; and
- (c) Questions and answers ~~(; and~~
- ~~(d) No~~), and/or discussion;
- (5) Has no more than six make-up hours of alternative instructor-led classroom instruction, delivering the same information that was missed.
- ~~((5))~~ (6) Has all students in a classroom session on the same lesson, with the exception of make-up lessons. Open enrollment or self-paced instruction is not permitted;
- ~~((6))~~ (7) Is not completed in fewer than ((thirty)) 30 calendar days;
- ~~((7))~~ (8) Includes comprehensive final written and behind the wheel examinations;
- ~~((8))~~ (9) Has a flow chart that indicates how the classroom and behind the wheel instruction are completed throughout the course;
- ~~((9))~~ (10) Includes information on the state of Washington's intermediate license requirements, restrictions, violations, and sanctions for violation of these requirements;
- ~~((10))~~ (11) Includes the delivery of instructional material developed by the department and the federally designated organ procurement organization for Washington state relating to organ and tissue donation awareness education; and
- ~~((11))~~ (12) Has a designated time for a parent, guardian, or employer night that is no less than one hour, which may fulfill one of the ((thirty)) 30 hours required for student training, and must include:
- (a) Instruction on the parent, guardian, or employer responsibilities and the importance of parent, guardian, or employer involvement with the teen driver;
- (b) Information on intermediate license laws, restrictions, and sanctions;
- (c) An introduction to the parent guide to teen driving; and
- (d) A questions and answers period.

[Statutory Authority: Chapter 46.82 RCW. WSR 19-07-058, § 308-108-150, filed 3/18/19, effective 4/18/19. Statutory Authority: RCW 46.82.290. WSR 09-21-092, § 308-108-150, filed 10/20/09, effective 1/1/10. Statutory Authority: RCW 46.82.290, 46.82.310, 46.82.320, 46.82.330, and 46.82.340. WSR 07-01-069, § 308-108-150, filed 12/18/06, effective 1/18/07. Statutory Authority: RCW 46.82.290. WSR 05-16-061, § 308-108-150, filed 7/29/05, effective 8/29/05.]

AMENDATORY SECTION (Amending WSR 17-21-026, filed 10/10/17, effective 11/10/17)

WAC 308-108-165 Prohibition on wireless communication devices during instruction. (1) Driving school instructors must not use personal electronic devices, hands-free or otherwise, that distract from or interfere with the behind the wheel or classroom instruction task. This includes the use of any communications devices that result in verbal or written text responses while conducting instruction. While supervising the operation of a vehicle, instructors are additionally prohibited from sending or receiving messages with these devices. Ring

volumes for these devices, or any phone in proximity, are to be silenced so as not to interfere in any way with the student learning or interacting with the instructor.

(2) This section does not apply to voice activated GPS devices or classroom devices that are being used as part of an approved curriculum. This section also does not preclude the use of devices to report illegal activity, summon medical or other emergency help, or prevent injury to a person or property, as permitted under RCW 46.61.672.

(3) An unreasonable risk associated with a failure to obey this section is a violation of RCW 18.235.130(4).

(4) This section does not prohibit the use of wireless communication devices during instruction if the use is to access a virtual classroom or in the case of an emergency.

[Statutory Authority: RCW 46.01.110, 46.20.2891, 46.82.290, and 46.90.010. WSR 17-21-026, § 308-108-165, filed 10/10/17, effective 11/10/17. Statutory Authority: RCW 46.82.290. WSR 09-21-093, § 308-108-165, filed 10/20/09, effective 11/20/09.]

AMENDATORY SECTION (Amending WSR 09-21-093, filed 10/20/09, effective 11/20/09)

WAC 308-108-170 Ensuring student accomplishment. (1) Each driver training school must have a written curriculum guide available to each instructor and such guide shall be used for student instruction.

(2) In order to receive a traffic safety education certificate, all students under the age of (~~eighteen~~) 18 must satisfactorily complete all portions of the course of instruction included in the student curriculum as approved by the driver instructors' advisory committee.

(3) In order to satisfactorily complete a school's driver training course, all students under the age of (~~eighteen~~) 18 must pass a comprehensive driving knowledge and skills test or tests that deals with all or many of the relevant details of the course curriculum that meets the standards established by the department.

(4) Each driver training school must assess the needs and progress of students and give appropriate direction for additional driving experience and/or (~~parent~~) guided practice provided by a licensed driver with at least five years of driving experience.

[Statutory Authority: RCW 46.82.290. WSR 09-21-093, § 308-108-170, filed 10/20/09, effective 11/20/09. Statutory Authority: RCW 46.82.290, 46.82.310, 46.82.320, 46.82.330, and 46.82.340. WSR 07-01-069, § 308-108-170, filed 12/18/06, effective 1/18/07. Statutory Authority: RCW 46.82.290. WSR 05-16-061, § 308-108-170, filed 7/29/05, effective 8/29/05.]

REPEALER

The following section of the Washington Administrative Code is repealed:

WAC 308-108-190 Emergency clause.

WSR 22-22-087
PERMANENT RULES
DEPARTMENT OF
RETIREMENT SYSTEMS

[Filed November 1, 2022, 2:46 p.m., effective December 2, 2022]

Effective Date of Rule: Thirty-one days after filing.

Purpose: Repeals WAC 415-108-170 Business hours, as the rule is no longer necessary. In compliance with RCW 42.04.060, the agency's business hours are posted on the agency's website and office building.

Citation of Rules Affected by this Order: Repealing WAC 415-108-170.

Statutory Authority for Adoption: RCW 41.50.050.

Adopted under notice filed as WSR 22-17-045 on August 11, 2022.

Number of Sections Adopted in Order to Comply with Federal Statute: New 0, Amended 0, Repealed 0; Federal Rules or Standards: New 0, Amended 0, Repealed 0; or Recently Enacted State Statutes: New 0, Amended 0, Repealed 0.

Number of Sections Adopted at the Request of a Nongovernmental Entity: New 0, Amended 0, Repealed 0.

Number of Sections Adopted on the Agency's own Initiative: New 0, Amended 0, Repealed 1.

Number of Sections Adopted in Order to Clarify, Streamline, or Reform Agency Procedures: New 0, Amended 0, Repealed 0.

Number of Sections Adopted using Negotiated Rule Making: New 0, Amended 0, Repealed 0; Pilot Rule Making: New 0, Amended 0, Repealed 0; or Other Alternative Rule Making: New 0, Amended 0, Repealed 0.

Date Adopted: November 1, 2022.

Tracy Guerin
Director

OTS-4038.1

REPEALER

The following section of the Washington Administrative Code is repealed:

WAC 415-108-170 Business hours.

WSR 22-22-104
PERMANENT RULES
OFFICE OF THE
INSURANCE COMMISSIONER

[Insurance Commissioner Matter R 2022-03—Filed November 2, 2022, 10:03 a.m., effective December 3, 2022]

Effective Date of Rule: Thirty-one days after filing.

Purpose: To amend existing rules as needed to be consistent with ESHB 1821 (chapter 213, Laws of 2022) regarding accessing and receiving audio-only telehealth.

Citation of Rules Affected by this Order: Amending WAC 284-170-130.

Statutory Authority for Adoption: RCW 48.02.060 and 48.43.735.

Adopted under notice filed as WSR 22-19-064 on September 16, 2022.

A final cost-benefit analysis is available by contacting Shari Maier, P.O. Box 40255, Olympia, WA 98504-0255, phone 360-725-7173, fax 360-586-3109, email Shari.Maier@oic.wa.gov.

Number of Sections Adopted in Order to Comply with Federal Statute: New 0, Amended 0, Repealed 0; Federal Rules or Standards: New 0, Amended 0, Repealed 0; or Recently Enacted State Statutes: New 0, Amended 1, Repealed 0.

Number of Sections Adopted at the Request of a Nongovernmental Entity: New 0, Amended 0, Repealed 0.

Number of Sections Adopted on the Agency's own Initiative: New 0, Amended 0, Repealed 0.

Number of Sections Adopted in Order to Clarify, Streamline, or Reform Agency Procedures: New 0, Amended 0, Repealed 0.

Number of Sections Adopted using Negotiated Rule Making: New 0, Amended 0, Repealed 0; Pilot Rule Making: New 0, Amended 0, Repealed 0; or Other Alternative Rule Making: New 0, Amended 0, Repealed 0.

Date Adopted: November 2, 2022.

Mike Kreidler
Insurance Commissioner

OTS-4074.2

AMENDATORY SECTION (Amending WSR 21-24-029, filed 11/22/21, effective 12/23/21)

WAC 284-170-130 Definitions. Except as defined in other sub-chapters and unless the context requires otherwise, the following definitions shall apply throughout this chapter.

(1) "Adverse determination" has the same meaning as the definition of adverse benefit determination in RCW 48.43.005, and includes:

(a) The determination includes any decision by a health carrier's designee utilization review organization that a request for a benefit under the health carrier's health benefit plan does not meet the health carrier's requirements for medical necessity, appropriateness, health care setting, level of care, or effectiveness or is determined to be experimental or investigational and the requested benefit is therefore denied, reduced, or terminated or payment is not provided or made, in whole or in part for the benefit;

(b) The denial, reduction, termination, or failure to provide or make payment, in whole or in part, for a benefit based on a determination by a health carrier or its designee utilization review organization of a covered person's eligibility to participate in the health carrier's health benefit plan;

(c) Any prospective review or retrospective review determination that denies, reduces, or terminates or fails to provide or make payment in whole or in part for a benefit;

(d) A rescission of coverage determination; or

(e) A carrier's denial of an application for coverage.

(2) "Allowed amount" has the meaning set forth in RCW 48.43.005.

(3) (a) "Audio-only telemedicine" means the delivery of health care services through the use of audio-only technology, permitting real-time communication between the patient at the originating site and the provider, for the purpose of diagnosis, consultation, or treatment.

(b) "Audio-only telemedicine" does not include:

(i) The use of facsimile, email, or text messages, unless the use of text-like messaging is necessary to ensure effective communication with individuals who have a hearing, speech, or other disability; or

(ii) The delivery of health care services that are customarily delivered by audio-only technology and customarily not billed as separate services by the provider, such as the sharing of laboratory results.

(4) "Authorization" or "certification" means a determination by the carrier that an admission, extension of stay, or other health care service has been reviewed and, based on the information provided, meets the clinical requirements for medical necessity, appropriateness, level of care, or effectiveness in relation to the applicable health plan.

(5) "Clinical review criteria" means the written screens, or screening procedures, decision rules, medical protocols, or clinical practice guidelines used by the carrier as an element in the evaluation of medical necessity and appropriateness of requested admissions, procedures, and services, including prescription drug benefits, under the auspices of the applicable health plan. Clinical approval criteria has the same meaning as clinical review criteria.

(6) "Covered health condition" means any disease, illness, injury or condition of health risk covered according to the terms of any health plan.

(7) "Covered person" or "enrollee" means an individual covered by a health plan including a subscriber, policyholder, or beneficiary of a group plan.

(8) "Disciplining authority" has the meaning set forth in RCW 18.130.020.

(9) "Distant site" has the meaning set forth in RCW 48.43.735.

(10) "Emergency medical condition" means the emergent and acute onset of a symptom or symptoms, including severe pain or emotional distress, that would lead a prudent layperson acting reasonably to believe that a health condition exists that requires immediate medical, mental health, or substance use disorder treatment attention, if failure to provide medical, mental health, or substance use disorder treatment attention would result in serious impairment to bodily functions or serious dysfunction of a bodily organ or part, or would place the person's health in serious jeopardy.

(11) "Emergency services" has the meaning set forth in RCW 48.43.005.

(12) "Enrollee point-of-service cost-sharing" or "cost-sharing" has the meaning set forth in RCW 48.43.005.

(13) "Established relationship" means the provider providing audio-only telemedicine has access to sufficient health records to ensure safe, effective, and appropriate care services and:

(a) For health care services included in the essential health benefits category of mental health and substance use disorder services, including behavioral health treatment:

(i) The covered person has had, within the past three years, at least one in-person appointment (~~within the past year~~), or at least one real-time interactive appointment using both audio and video technology, with:

(A) The provider providing audio-only telemedicine (~~with~~);

(B) A provider employed at the same medical group, at the same clinic, or by the same integrated delivery system operated by a carrier licensed under chapter 48.44 or 48.46 RCW as the provider providing audio-only telemedicine (~~with~~); or

(C) A locum tenens or other provider who is the designated back up or substitute provider for the provider providing audio-only telemedicine who is on leave and is not associated with an established medical group, clinic, or integrated delivery system operated by a carrier licensed under chapter 48.44 or 48.46 RCW; or

(~~(b)~~) (ii) The covered person was referred to the provider providing audio-only telemedicine by another provider who has:

(A) Had, within the past three years, at least one in-person appointment, or at least one real-time interactive appointment using both audio and video technology, with the covered person (~~within the past year and has~~); and

(B) Provided relevant medical information to the provider providing audio-only telemedicine.

(C) A referral includes circumstances in which the provider who has had at least one in-person appointment, or at least one real-time interactive appointment using both audio and video technology, with the covered person participates in the audio-only telemedicine encounter with the provider to whom the covered person has been referred.

(b) For any other health care service:

(i) The covered person has had, within the past two years, at least one in-person appointment, or, until January 1, 2024, at least one real-time interactive appointment using both audio and video technology, with:

(A) The provider providing audio-only telemedicine; or

(B) A provider employed at the same medical group, at the same clinic, or by the same integrated delivery system operated by a carrier licensed under chapter 48.44 or 48.46 RCW as the provider providing audio-only telemedicine; or

(C) A locum tenens or other provider who is the designated back up or substitute provider for the provider providing audio-only telemedicine who is on leave and is not associated with an established medical group, clinic, or integrated delivery system operated by a carrier licensed under chapter 48.44 or 48.46 RCW; or

(ii) The covered person was referred to the provider providing audio-only telemedicine by another provider who has:

(A) Had, within the past two years, at least one in-person appointment or, until January 1, 2024, at least one real-time interactive appointment using both audio and video technology, with the covered person; and

(B) Provided relevant medical information to the provider providing audio-only telemedicine.

(C) A referral includes circumstances in which the provider who has had at least one in-person appointment, or, until January 1, 2024, at least one real-time interactive appointment using both audio and video technology, with the covered person participating in the audio-only telemedicine encounter with the provider to whom the covered person has been referred.

(14) "Facility" means an institution providing health care services including, but not limited to, hospitals and other licensed inpatient centers, ambulatory surgical or treatment centers, skilled nursing centers, residential treatment centers, diagnostic, laboratory, and imaging centers, and rehabilitation and other therapeutic settings, and as defined in RCW 48.43.005.

(15) "Formulary" means a listing of drugs used within a health plan.

(16) "Grievance" has the meaning set forth in RCW 48.43.005.

(17) "Health care provider" or "provider" means:

(a) A person regulated under Title 18 RCW or chapter 70.127 RCW, to practice health or health-related services or otherwise practicing health care services in this state consistent with state law; or

(b) An employee or agent of a person described in (a) of this subsection, acting in the course and scope of his or her employment.

(18) "Health care service" or "health service" means that service offered or provided by health care facilities and health care providers relating to the prevention, cure, or treatment of illness, injury, or disease.

(19) "Health carrier" or "carrier" means a disability insurance company regulated under chapter 48.20 or 48.21 RCW, a health care service contractor as defined in RCW 48.44.010, and a health maintenance organization as defined in RCW 48.46.020, and includes "issuers" as that term is used in The Patient Protection and Affordable Care Act (P.L. 111-148, as amended (2010)).

(20) "Health plan" or "plan" means any individual or group policy, contract, or agreement offered by a health carrier to provide, arrange, reimburse, or pay for health care service except the following:

(a) Long-term care insurance governed by chapter 48.84 RCW;

(b) Medicare supplemental health insurance governed by chapter 48.66 RCW;

(c) Limited health care service offered by limited health care service contractors in accordance with RCW 48.44.035;

(d) Disability income;

(e) Coverage incidental to a property/casualty liability insurance policy such as automobile personal injury protection coverage and homeowner guest medical;

(f) Workers' compensation coverage;

(g) Accident only coverage;

(h) Specified disease and hospital confinement indemnity when marketed solely as a supplement to a health plan;

(i) Employer-sponsored self-funded health plans;

(j) Dental only and vision only coverage; and

(k) Plans deemed by the insurance commissioner to have a short-term limited purpose or duration, or to be a student-only plan that is guaranteed renewable while the covered person is enrolled as a regular full-time undergraduate or graduate student at an accredited higher education institution, after a written request for such classification

by the carrier and subsequent written approval by the insurance commissioner.

(21) "Hospital" has the meaning set forth in RCW 48.43.735.

(22) "Indian health care provider" means:

(a) The Indian Health Service, an agency operated by the U.S. Department of Health and Human Services established by the Indian Health Care Improvement Act, Section 601, 25 U.S.C. Sec. 1661;

(b) An Indian tribe, as defined in the Indian Health Care Improvement Act, Section 4(14), 25 U.S.C. Sec. 1603(14), that operates a health program under a contract or compact to carry out programs of the Indian Health Service pursuant to the Indian Self-Determination and Education Assistance Act (ISDEAA), 25 U.S.C. Sec. 450 et seq.;

(c) A tribal organization, as defined in the Indian Health Care Improvement Act, Section 4(26), 25 U.S.C. Sec. 1603(26), that operates a health program under a contract or compact to carry out programs of the Indian Health Service pursuant to the ISDEAA, 25 U.S.C. Sec. 450 et seq.;

(d) An Indian tribe, as defined in the Indian Health Care Improvement Act, Section 4(14), 25 U.S.C. Sec. 1603(14), or tribal organization, as defined in the Indian Health Care Improvement Act, Section 4(26), 25 U.S.C. Sec. 1603(26), that operates a health program with funding provided in whole or part pursuant to 25 U.S.C. Sec. 47 (commonly known as the Buy Indian Act); or

(e) An urban Indian organization that operates a health program with funds in whole or part provided by Indian Health Service under a grant or contract awarded pursuant to Title V of the Indian Health Care Improvement Act, Section 4(29), 25 U.S.C. Sec. 1603(29).

(23) "Managed care plan" means a health plan that coordinates the provision of covered health care services to a covered person through the use of a primary care provider and a network.

(24) "Medically necessary" or "medical necessity" in regard to mental health services and pharmacy services is a carrier determination as to whether a health service is a covered benefit because the service is consistent with generally recognized standards within a relevant health profession.

(25) "Mental health provider" means a health care provider or a health care facility authorized by state law to provide mental health services.

(26) "Mental health services" means in-patient or out-patient treatment including, but not limited to, partial hospitalization, residential treatment, out-patient facility-based treatment, intensive outpatient treatment, emergency services, or prescription drugs to manage, stabilize, or ameliorate the effects of a mental disorder listed in the most current version of the Diagnostic and Statistical Manual of Mental Disorders (DSM) published by the American Psychiatric Association, including diagnoses and treatment for substance use disorder.

(27) "Network" means the group of participating providers and facilities providing health care services to a particular health plan or line of business (individual, small, or large group). A health plan network for issuers offering more than one health plan may be smaller in number than the total number of participating providers and facilities for all plans offered by the carrier.

(28) "Originating site" means the physical location of a patient receiving health care services through telemedicine, and includes those sites described in WAC 284-170-433.

(29) "Out-patient therapeutic visit" or "out-patient visit" means a clinical treatment session with a mental health provider of a duration consistent with relevant professional standards used by the carrier to determine medical necessity for the particular service being rendered, as defined in Physicians Current Procedural Terminology, published by the American Medical Association.

(30) "Participating provider" and "participating facility" mean a facility or provider who, under a contract with the health carrier or with the carrier's contractor or subcontractor, has agreed to provide health care services to covered persons with an expectation of receiving payment, other than coinsurance, copayments, or deductibles, from the health carrier rather than from the covered person.

(31) "Patient consent" means a voluntary and informed decision by a patient, following an explanation by the provider or auxiliary personnel under the general supervision of the provider presented in a manner understandable to the patient that is free of undue influence, fraud or duress, to consent to a provider billing the patient or the patient's health plan for an audio-only telemedicine service under RCW 48.43.735 or WAC 284-170-433.

(32) "Person" means an individual, a corporation, a partnership, an association, a joint venture, a joint stock company, a trust, an unincorporated organization, any similar entity, or any combination of the foregoing.

(33) "Pharmacy services" means the practice of pharmacy as defined in chapter 18.64 RCW and includes any drugs or devices as defined in chapter 18.64 RCW.

(34) "Primary care provider" means a participating provider who supervises, coordinates, or provides initial care or continuing care to a covered person, and who may be required by the health carrier to initiate a referral for specialty care and maintain supervision of health care services rendered to the covered person.

(35) "Preexisting condition" means any medical condition, illness, or injury that existed any time prior to the effective date of coverage.

(36) "Premium" means all sums charged, received, or deposited by a health carrier as consideration for a health plan or the continuance of a health plan. Any assessment or any "membership," "policy," "contract," "service," or similar fee or charge made by a health carrier in consideration for a health plan is deemed part of the premium. "Premium" shall not include amounts paid as enrollee point-of-service cost-sharing.

(37) "Real time communication" means synchronous and live communication between a provider and a patient. It does not include delayed or recorded messages, such as email, facsimile or voicemail.

(38) "Same amount of compensation" means providers are reimbursed by a carrier using the same allowed amount for telemedicine services as they would if the service had been provided in-person unless negotiation has been undertaken under RCW 48.43.735 or WAC 284-170-433(2). Where consumer cost-sharing applies to telemedicine services, the consumer's payment combined with the carrier's payment must be the same amount of compensation, or allowed amount, as the carrier would pay the provider if the telemedicine service had been provided in person. Where an alternative payment methodology other than fee-for-service payment would apply to an in-person service, "same amount of compensation" means providers are reimbursed by a carrier using the same alternative payment methodology that would be used for the same service

if provided in-person, unless negotiation has been undertaken under RCW 48.43.735 or WAC 284-170-433(2).

(39) "Service area" means the geographic area or areas where a specific product is issued, accepts members or enrollees, and covers provided services. A service area must be defined by the county or counties included unless, for good cause, the commissioner permits limitation of a service area by zip code. Good cause includes geographic barriers within a service area, or other conditions that make offering coverage throughout an entire county unreasonable.

(40) "Small group plan" means a health plan issued to a small employer as defined under RCW 48.43.005(34) comprising from one to 50 eligible employees.

(41) "Store and forward technology" has the meaning set forth in RCW 48.43.735.

(42) "Substance use disorder services" means in-patient or out-patient treatment including, but not limited to, partial hospitalization, residential treatment, or out-patient facility-based treatment, intensive outpatient treatment, emergency services, or prescription drugs to manage, stabilize, or ameliorate the effects of a substance use disorder listed in the most current version of the *Diagnostic and Statistical Manual of Mental Disorders* (DSM) published by the American Psychiatric Association, including diagnoses and treatment for substance use disorder.

(43) "Substitute drug" means a prescription medication, drug or therapy that a carrier covers based on an exception request. When the exception request is based on therapeutic equivalence, a substitute drug means a therapeutically equivalent substance as defined in chapter 69.41 RCW.

(44) "Supplementary pharmacy services" or "other pharmacy services" means pharmacy services involving the provision of drug therapy management and other services not required under state and federal law but that may be rendered in connection with dispensing, or that may be used in disease prevention or disease management.

(45) "Telemedicine" means the delivery of health care services through the use of interactive audio and video technology or audio-only technology, permitting real-time communication between the patient at the originating site and the provider, for the purpose of diagnosis, consultation, or treatment. For purposes of this chapter, "telemedicine" does not include facsimile, email, or text messaging, unless the use of text-like messaging is necessary to ensure effective communication with individuals who have a hearing, speech, or other disability.

[Statutory Authority: RCW 48.43.735(9). WSR 21-24-029, § 284-170-130, filed 11/22/21, effective 12/23/21. Statutory Authority: RCW 48.02.060 and 48.43.765. WSR 21-01-094 (Matter No. R 2019-05), § 284-170-130, filed 12/11/20, effective 1/11/21. Statutory Authority: RCW 48.02.060. WSR 16-07-144 (Matter No. R 2016-01), § 284-170-130, filed 3/23/16, effective 4/23/16.]